

Features

- Single-Supply Operation from +3V ~ +30V
 - Dual-Supply Operation from $\pm 1.5V \sim \pm 15V$
 - Gain-Bandwidth Product: 1MHz (Typ)
 - Low Input Bias Current: 45nA (Typ)
 - Low Offset Voltage: 5mV (Max)
 - Quiescent Current: 500 μ A per Amplifier (Typ)
 - Operating Temperature: -25°C ~ +85°C
- Small Package:
 - LM321 Available in SOT23-5 Package
 - LM358 Available in SOP-8 and MSOP-8 Packages
 - LM324 Available in SOP-14 Package

General Description

The LM321/358/324 family have a high gain-bandwidth product of 1MHz, a slew rate of 0.4V/ μ s, and a quiescent current of 500 μ A/amplifier at 5V. The LM321/358/324 family is designed to provide optimal performance in low voltage and low noise systems. The maximum input offset voltage is 5mV for LM321/358/324 family. The operating range is from 3V to 30V. The LM321 single is available in Green SOT-23-5 package. The LM358 Dual is available in Green SOP-8 and MSOP-8 packages. The LM324 Quad is available in Green SOP-14 package.

Applications

- Walkie-Talkie
- Battery Management Solution
- Transducer Amplifiers
- Summing Amplifiers
- Multivibrators
- Oscillators
- Portable Systems

Pin Configuration

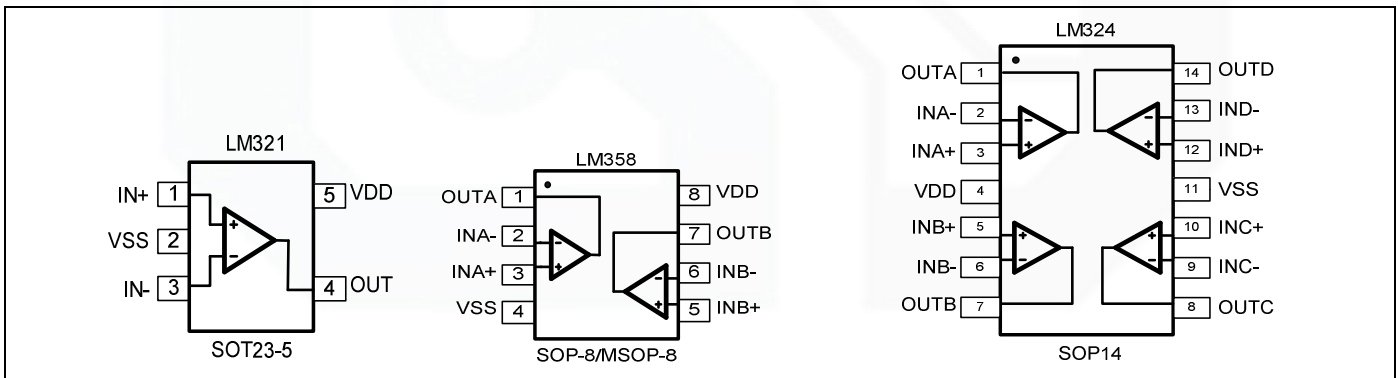

Figure 1. Pin Assignment Diagram

Absolute Maximum Ratings

Condition	Symbol	Max
Power Supply Voltage	V _{CC}	± 16V or 32V
Differential input voltage	V _{I(DIFF)}	32V
Input Voltage	V _I	-0.3V~32V
Operating Temperature Range	T _{opr}	-25°C ~+85°C
Storage Temperature Range	T _{stg}	-65°C ~+150°C

Note: Stress greater than those listed under Absolute Maximum Ratings may cause permanent damage to the device. This is a stress rating only and functional operation of the device at these or any other conditions outside those indicated in the operational sections of this specification are not implied. Exposure to absolute maximum rating conditions for extended periods may affect reliability.

Package/Ordering Information

MODEL	CHANNEL	ORDER NUMBER	PACKAGE DESCRIPTION	PACKAGE OPTION	MARKING INFORMATION
LM321	Single	LM321-TR	SOT23-5	Tape and Reel,3000	LM321
LM358	Dual	LM358-SR	SOP-8	Tape and Reel,4000	LM358
		LM358-MR	MSOP-8	Tape and Reel,3000	LM358
LM324	Quad	LM324-SR	SOP-14	Tape and Reel,2500	LM324

Electrical Characteristics

(At $V_S = +15V$, $T_A = 25^\circ C$, unless otherwise noted.)

PARAMETER	SYMBOL	CONDITIONS	LM321/358/324			
			TYP	MIN/MAX OVER TEMPERATURE		
			+25°C	+25°C	UNITS	MIN/MAX
INPUT CHARACTERISTICS						
Input Offset Voltage	V_{OS}	$V_{CM} = V_S/2$	0.4	5	mV	MAX
Input Bias Current	I_B		45		nA	TYP
Input Offset Current	I_{OS}		5		nA	TYP
Common-Mode Voltage Range	V_{CM}	$V_S = 5.5V$	-0.1 to +4		V	TYP
Common-Mode Rejection Ratio	CMRR	$V_{CM} = 0V$ to $V_S - 1.5V$	90	70	dB	MIN
Open-Loop Voltage Gain	A_{OL}	$R_L = 5k\Omega$, $V_O = 1V$ to $11V$	100	85	dB	MIN
Input Offset Voltage Drift	$\Delta V_{OS}/\Delta T$		7		$\mu V/^\circ C$	TYP
OUTPUT CHARACTERISTICS						
Output Voltage Swing from Rail	V_{OH}	$R_L = 2k\Omega$	11		V	MIN
	V_{OL}	$R_L = 2k\Omega$	5	20	mV	MAX
	V_{OH}	$R_L = 10k\Omega$	12	13	V	MIN
	V_{OL}	$R_L = 10k\Omega$	5	20	mV	MAX
Output Current	I_{SOURCE}	$R_L = 10\Omega$ to $V_S/2$	40	60	mA	MAX
	I_{SINK}		40	60		
POWER SUPPLY						
Operating Voltage Range				3	V	MIN
				30	V	MAX
Power Supply Rejection Ratio	PSRR	$V_S = +5V$ to $+30V$, $V_{CM} = +0.5V$	100	70	dB	MIN
Quiescent Current / Amplifier	I_Q	$V_S = 30V$, $R_L = \infty$	0.5	2.5	mA	MAX
DYNAMIC PERFORMANCE						
Gain-Bandwidth Product	GBP		1		MHz	TYP
Slew Rate	SR	$G = +1$, 2V Output Step	0.4		V/ μs	TYP

Typical Performance characteristics

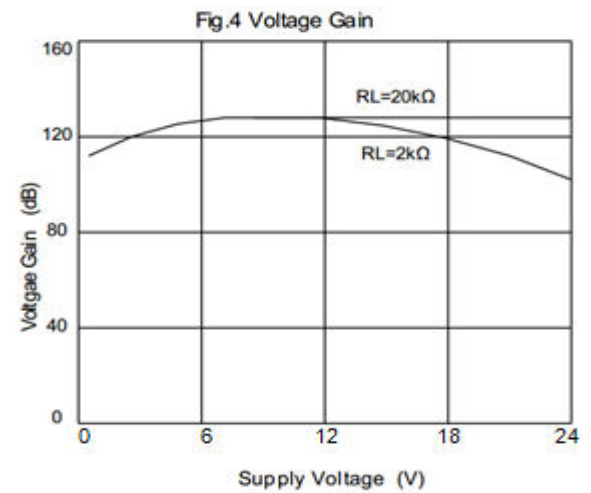
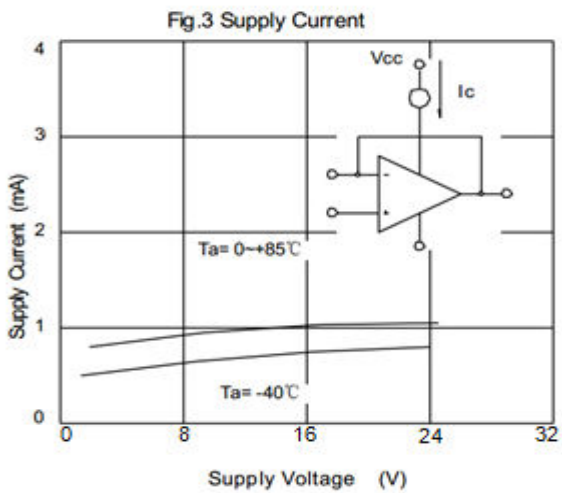
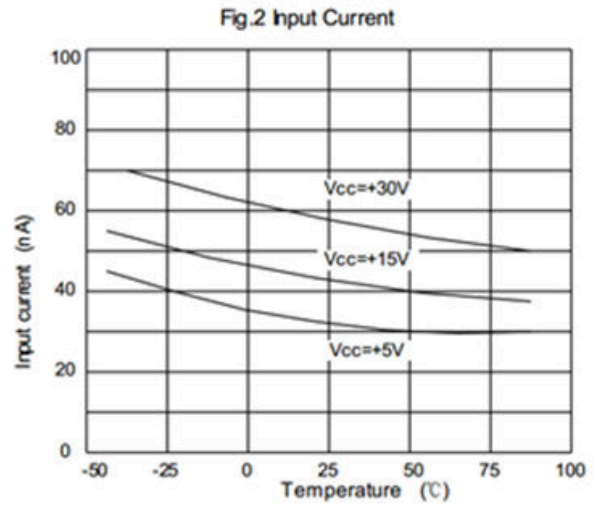
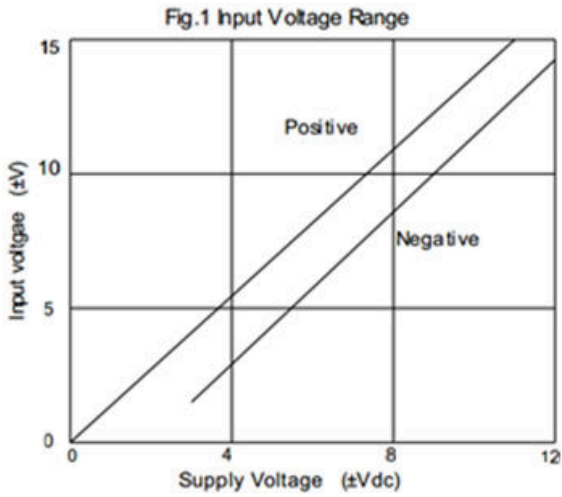

Application Note

Size

LM321/358/324 family series op amps are unity-gain stable and suitable for a wide range of general-purpose applications. The small footprints of the LM321/358/324 family packages save space on printed circuit boards and enable the design of smaller electronic products.

Power Supply Bypassing and Board Layout

LM321/358/324 family series operates from a single 3V to 30V supply or dual $\pm 1.5V$ to $\pm 15V$ supplies. For best performance, a $0.1\mu F$ ceramic capacitor should be placed close to the V_{DD} pin in single supply operation. For dual supply operation, both V_{DD} and V_{SS} supplies should be bypassed to ground with separate $0.1\mu F$ ceramic capacitors.

Low Supply Current

The low supply current (typical $500\mu A$ per channel) of LM321/358/324 family will help to maximize battery life.

Operating Voltage

LM321/358/324 family operates under wide input supply voltage (3V to 30V). In addition, all temperature specifications apply from $-25^\circ C$ to $+85^\circ C$. Most behavior remains unchanged throughout the full operating voltage range. These guarantees ensure operation throughout the single Li-Ion battery lifetime.

Capacitive Load Tolerance

The LM321/358/324 family is optimized for bandwidth and speed, not for driving capacitive loads. Output capacitance will create a pole in the amplifier's feedback path, leading to excessive peaking and potential oscillation. If dealing with load capacitance is a requirement of the application, the two strategies to consider are (1) using a small resistor in series with the amplifier's output and the load capacitance and (2) reducing the bandwidth of the amplifier's feedback loop by increasing the overall noise gain. Figure 2. shows a unity gain follower using the series resistor strategy. The resistor isolates the output from the capacitance and, more importantly, creates a zero in the feedback path that compensates for the pole created by the output capacitance.

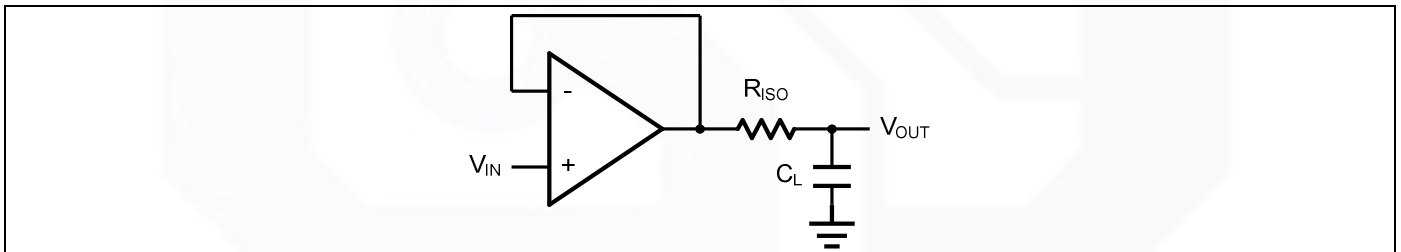

Figure 2. Indirectly Driving a Capacitive Load Using Isolation Resistor

The bigger the R_{ISO} resistor value, the more stable V_{OUT} will be. However, if there is a resistive load R_L in parallel with the capacitive load, a voltage divider (proportional to R_{ISO}/R_L) is formed, this will result in a gain error.

The circuit in Figure 3 is an improvement to the one in Figure 2. R_F provides the DC accuracy by feed-forward the V_{IN} to R_L . C_F and R_{ISO} serve to counteract the loss of phase margin by feeding the high frequency component of the output signal back to the amplifier's inverting input, thereby preserving the phase margin in the overall feedback loop. Capacitive drive can be increased by increasing the value of C_F . This in turn will slow down the pulse response.

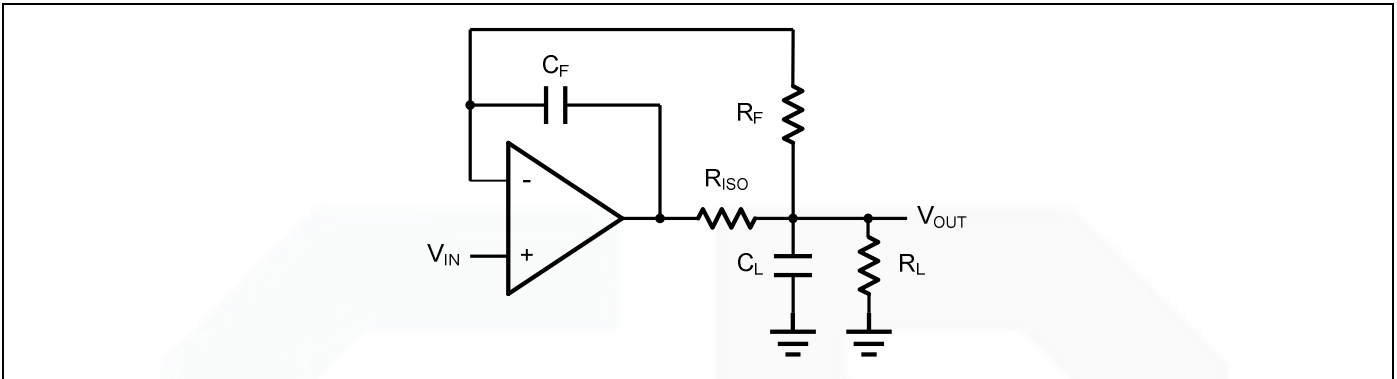

Figure 3. Indirectly Driving a Capacitive Load with DC Accuracy

Typical Application Circuits

Differential amplifier

The differential amplifier allows the subtraction of two input voltages or cancellation of a signal common to the two inputs. It is useful as a computational amplifier in making a differential to single-end conversion or in rejecting a common mode signal. Figure 4. shows the differential amplifier using LM321/358/324 family.

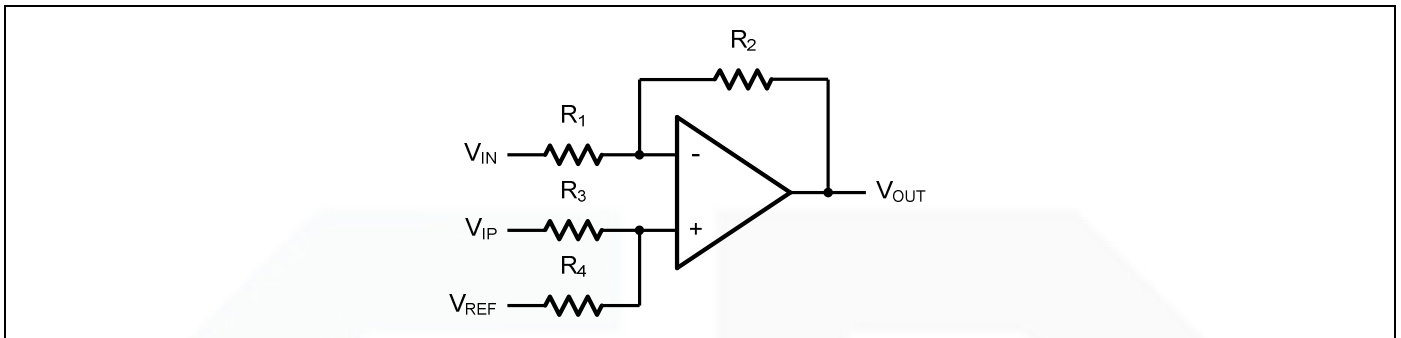

Figure 4. Differential Amplifier

$$V_{OUT} = \left(\frac{R_1 + R_2}{R_3 + R_4} \right) \frac{R_4}{R_1} V_{IN} - \frac{R_2}{R_1} V_{IP} + \left(\frac{R_1 + R_2}{R_3 + R_4} \right) \frac{R_3}{R_1} V_{REF}$$

If the resistor ratios are equal (i.e. $R_1 = R_3$ and $R_2 = R_4$), then

$$V_{OUT} = \frac{R_2}{R_1} (V_{IP} - V_{IN}) + V_{REF}$$

Low Pass Active Filter

The low pass active filter is shown in Figure 5. The DC gain is defined by $-R_2/R_1$. The filter has a -20dB/decade roll-off after its corner frequency $f_c = 1/(2\pi R_3 C_1)$.

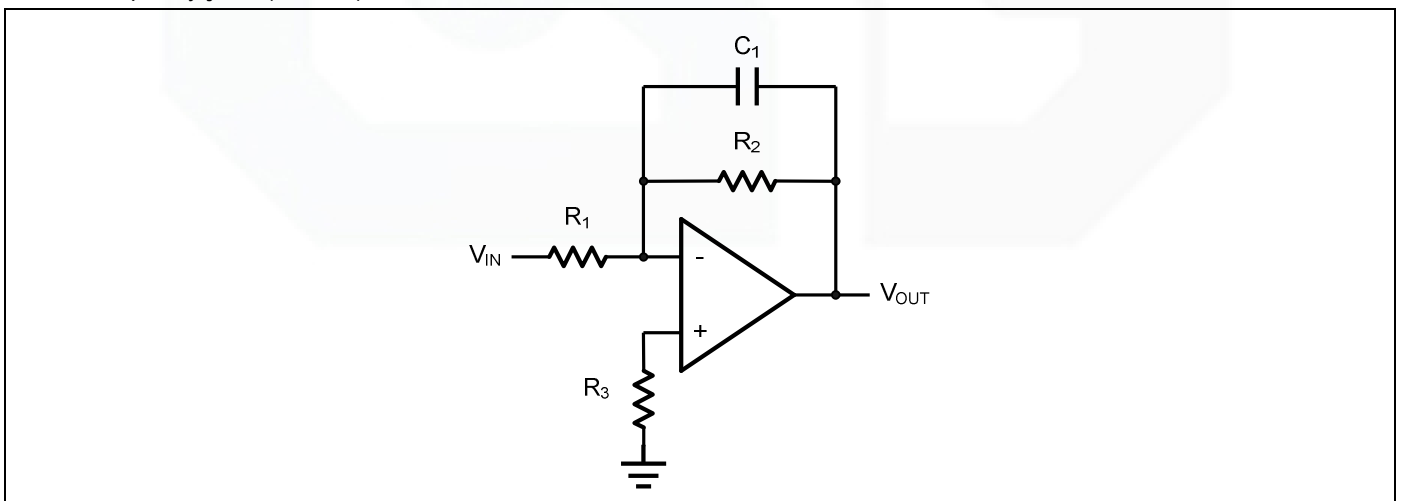

Figure 5. Low Pass Active Filter

Instrumentation Amplifier

The triple LM321/358/324 family can be used to build a three-op-amp instrumentation amplifier as shown in Figure 6. The amplifier in Figure 6 is a high input impedance differential amplifier with gain of R_2/R_1 . The two differential voltage followers assure the high input impedance of the amplifier.

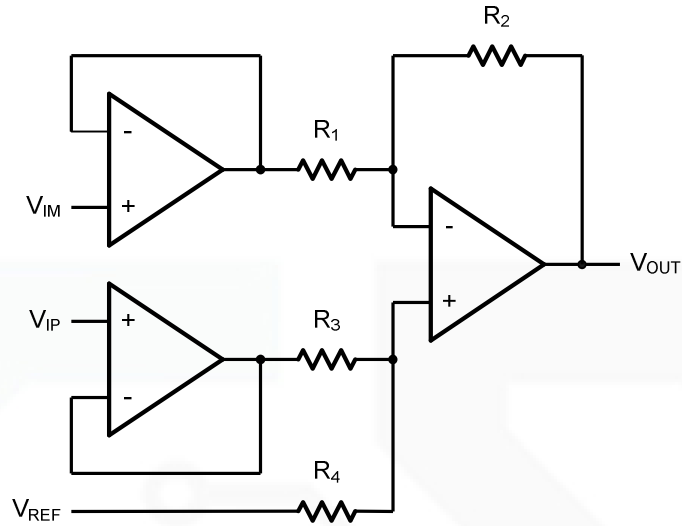
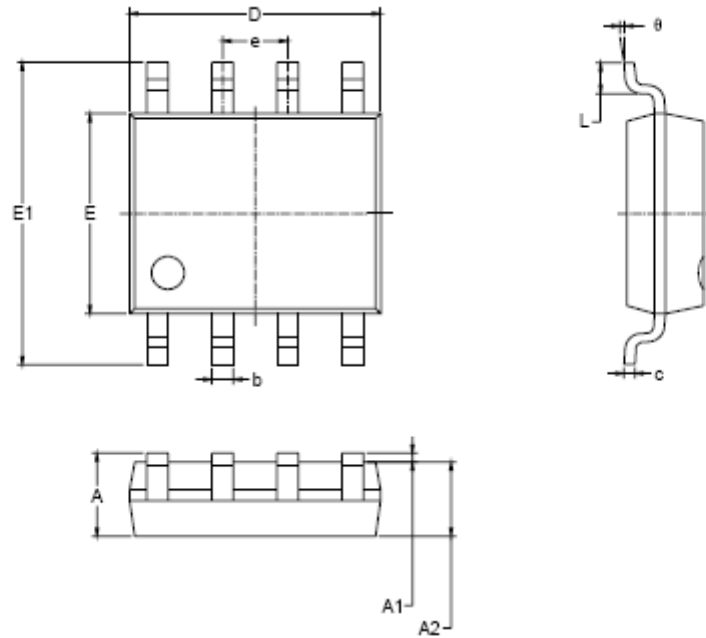
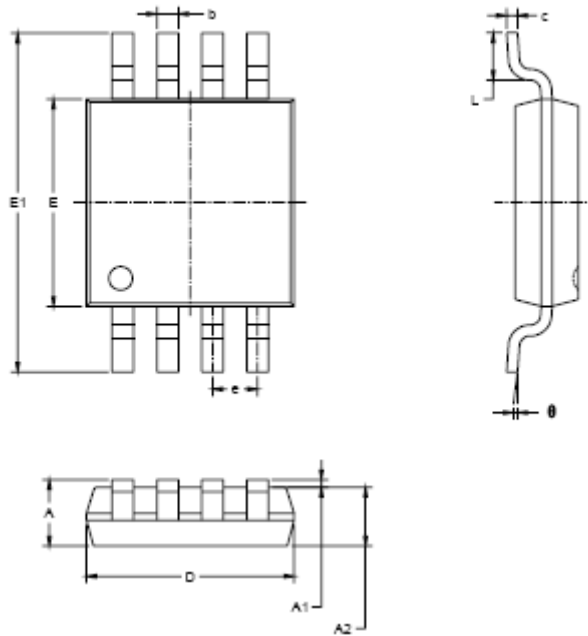

Figure 6. Instrument Amplifier

Package Information
SOP-8

Symbol	Dimensions In Millimeters		Dimensions In Inches	
	MIN	MAX	MIN	MAX
A	1.350	1.750	0.053	0.069
A1	0.100	0.250	0.004	0.010
A2	1.350	1.550	0.053	0.061
b	0.330	0.510	0.013	0.020
c	0.170	0.250	0.006	0.010
D	4.700	5.100	0.185	0.200
E	3.800	4.000	0.150	0.157
E1	5.800	6.200	0.228	0.244
e	1.27 BSC		0.050 BSC	
L	0.400	1.270	0.016	0.050
θ	0°	8°	0°	8°

MSOP-8



Symbol	Dimensions In Millimeters		Dimensions In Inches	
	MIN	MAX	MIN	MAX
A	0.820	1.100	0.032	0.043
A1	0.020	0.150	0.001	0.006
A2	0.750	0.950	0.030	0.037
b	0.250	0.380	0.010	0.015
c	0.090	0.230	0.004	0.009
D	2.900	3.100	0.114	0.122
E	2.900	3.100	0.114	0.122
E1	4.750	5.050	0.187	0.199
e	0.650 BSC		0.026 BSC	
L	0.400	0.800	0.016	0.031
θ	0°	6°	0°	6°

SOP-14

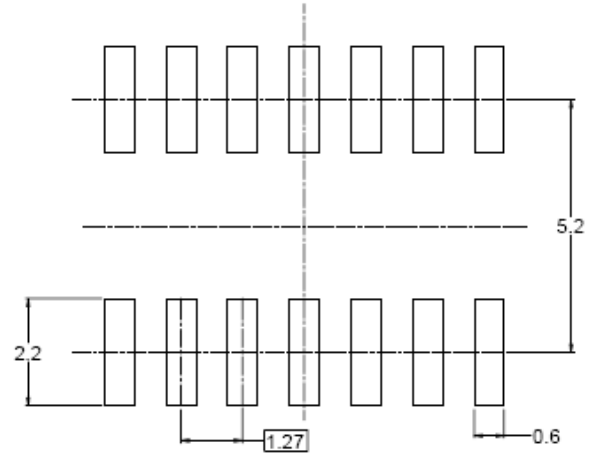
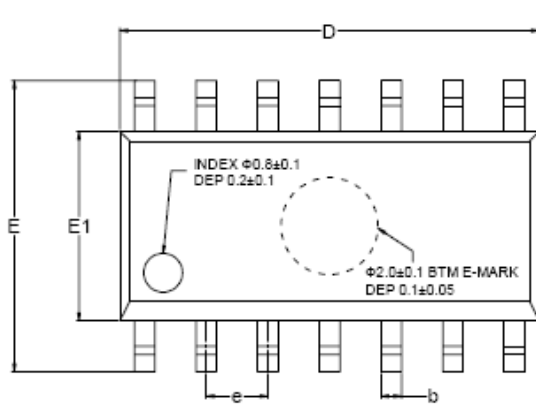

RECOMMENDED LAND PATTERN (Unit: mm)

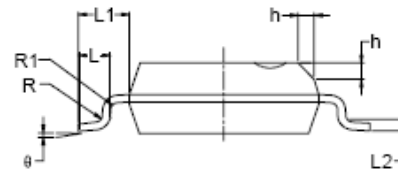
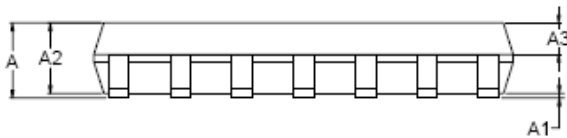

Symbol	Dimensions In Millimeters			Dimensions In Inches		
	MIN	MOD	MAX	MIN	MOD	MAX
A	1.35		1.75	0.053		0.069
A1	0.10		0.25	0.004		0.010
A2	1.25		1.65	0.049		0.065
A3	0.55		0.75	0.022		0.030
b	0.36		0.49	0.014		0.019
D	8.53		8.73	0.336		0.344
E	5.80		6.20	0.228		0.244
E1	3.80		4.00	0.150		0.157
e	1.27 BSC			0.050 BSC		
L	0.45		0.80	0.018		0.032
L1	1.04 REF			0.040 REF		
L2	0.25 BSC			0.01 BSC		
R	0.07			0.003		
R1	0.07			0.003		
h	0.30		0.50	0.012		0.020
θ	0°		8°	0°		8°

SOT23-5

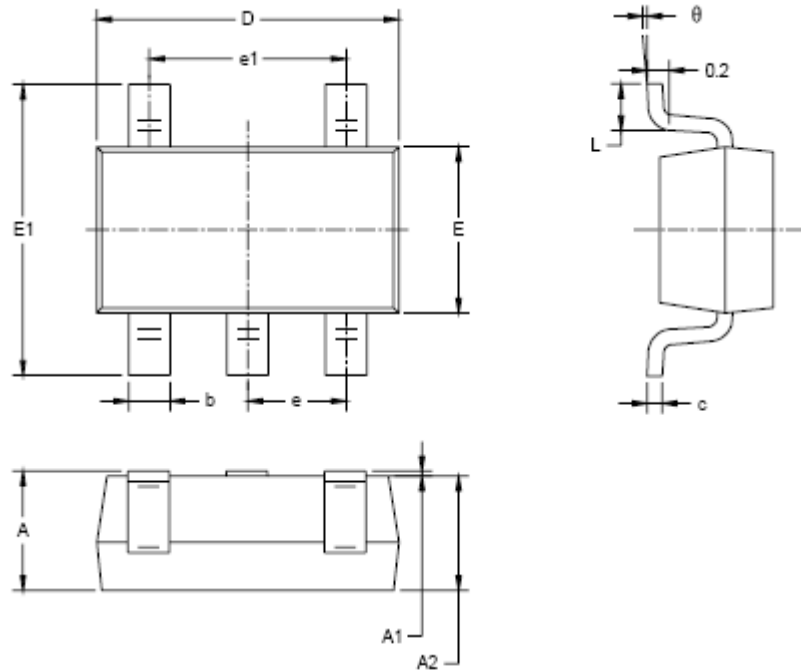

Symbol	Dimensions In Millimeters		Dimensions In Inches	
	MIN	MAX	MIN	MAX
A	1.050	1.250	0.041	0.049
A1	0.000	0.100	0.000	0.004
A2	1.050	1.150	0.041	0.045
b	0.300	0.500	0.012	0.020
c	0.100	0.200	0.004	0.008
D	2.820	3.020	0.111	0.119
E	1.500	1.700	0.059	0.067
E1	2.650	2.950	0.104	0.116
e	0.950 BSC		0.037 BSC	
e1	1.900 BSC		0.075 BSC	
L	0.300	0.600	0.012	0.024
θ	0°	8°	0°	8°

单击下面可查看定价，库存，交付和生命周期等信息

[>>Gainsil\(聚洵\)](#)