

APPROVAL SPECIFICATIONS

Title. 拨动开关 _____

Product Model. SS12F17-G3/048 _____

Customer's Part NO. _____

Customer's Model: _____

Customer's Approval Requested.

Please return this copy as a certification of your approval.

Checked by: _____ Date: _____

Approved by: _____ Date: _____

APPROVE	REVIEW	POLT
Jack Wu	孙斌	徐明娥

Shenzhen Gangyuan Microkey Technology Co.,ltd

Shenzhen Gangyuan Industry Development Co.,Ltd		文件编号SPC NO:	SS12F001	版本VERSION	A
深圳市港源实业发展有限公司		页数 PAGE	1	共 OF	3
SPECIFICATION 规格书		日期 DATE:	2012-6-27		
产品名称 MODEL NO SS12F17-G3/048		系列SERIES: SLIDE SWITCH			
1. RATING (额定值): DC 60V 0.3A					
2. FUNCTION(接触型式): 1 P 2 T					
3. TIMING (时间特性): SHORTING					
4. ELECTRICAL CHARACTERISTICS(电气性能规格):					
ITEM 项目		TEST CONDITIONS 测试条件		PERFORMANCE 规格	
4.1	CONTACT RESISTANCE 接触电阻	MEASURED AT SMALL CURRENT 1000HZ (100MA OR LESS)在微小电流(100MA)以下测试.		80MΩ MAX 80毫欧以下	
4.2	INSULATION RESISTANCE 绝缘电阻	APPLY A VOLTAGE OF 500V DC SHALL BE APPLIED FOR 1 MIN AFTER WHICH MEASUREMENT BE MADE: (1) BETWEEN TERMINALS. (2) BETWEEN INDIVIDUAL TERMINALS AND FRAME. 输入 500V DC 电压1分钟,按以下接触方法测试: (1) 排脚相互之间. (2) 排脚与外壳之间.		100MΩ MIN. 100 兆欧以上.	
4.3	DIELECTRIC STRENGTH 耐电压	AC 500V RMS(50-60HZ) FOR 1 MIN TRIP CURRENT:0.5A (1)BETWEEN TERMINALS. (2)BETWEEN INDIVIDUAL TERMINALS AND FRAME. 输入 AC 500V(50-60HZ)电压,1分钟感度电流为0.5MA,按以下接触方法测试: (1) 排脚相互之间. (2) 排脚与外壳之间.		WITHOUT DAMAGE TO PARTS ARCING OR BREAKDOWN, ETC. 没有绝缘破坏等异常.	
5	MECHANICAL CHARACTERISTICS (机械性能规格)				
5.1	OPERATING FORCE 作动力	MEASUREMENT SHALL BE MADE AT THE NEAREST POINT OF THE COMPONENT OR AT THE POINT 3MM FROM THE TIP OF THE ACTUATOR (KNOB). 在距离胶柄前端3MM作测定点.		180g±100g	
5.2	TERMINAL STRENGTH 端子强度	A STATIC LOAD OF 300gf SHALL BE APPLIED TO THE TERMINAL FOR 15 SEC. IN ANY DIRECTION 在排脚前端任意一个方向加300gf力度测试, 时间为15秒。		ELECTRICAL CHARACTERISTICS SHALL BE SATISFIED WITHOUT DAMAGE OR EXCESSIVE LOOSENESS OF TERMINALS. 在排脚中没有裂开, 松动等异常, 满足于机械.电气性能.	
5.3	DISPLACEMENT OF ACTUATOR (KNOB) 柄强度	A STATIC LOAD OF 10 N(1Kgf)SHALL BE APPLIED TO THE TOP OF THE ACTUATOR(KNOD) AND THEN DISPLACEMENT SHALL BE MEASURED TO THE DIRECTION OF THE ARROW. 在柄的前端施加1kg的力度, 位移应沿印记的方向上定。		THE LEVER SHALL HAVE NO SERIOUS DEFORMATION AND FUNCTION IS NORMALLY. 柄部无严重变形,可以正常工作.	
编写PREPARED BY		审核 CHECKED BY	批准 APPROVED BY		 受控副本印章 CONTROL COPY CHOP
陈翠兰		邓振理	邓祝用		

Shenzhen Gangyuan Industry Development Co.,Ltd		文件编号 SPC NO	SS12F001	版本VERSION	A
深圳市港源实业发展有限公司		页数 PAGE	2	共 OF	3
SPECIFICATION 规格书		日期 DATE: 2012-6-27			
6、ENDURANCE CHARACTERISTICS (耐久性):					
ITEM 项目		TEST CONDITIONS 测试条件		PERFORMANCE 规格	
6、1	LIFE TEST 寿命试验	<p>ENDURANCE WITHOUT LOADING: A SWITCH SHALL BE SUBJECTED TO 10 '000 CYCLES AT A SPEED OF 15 TO 18 CYCLES PER MINUTE WITHOUT LOADING 无负荷: 在无负荷的条件下以每分钟15 ~ 18 回的速度进行 10、000 次的测试.</p>		<p>(1) CONTACT RESISTANCE (接触电阻) 100 MAX. 100 毫欧以下。 (2) INSULATION RESISTANCE (绝缘电阻) 50 MIN. 50 兆欧以上。 (3) WITHSTAND VOLTAGE (耐电压) AC 500V,1 MINUTE.AC 500V 1 分钟 (4) OPERATING FORCE (作动力) ±30% INITIAL UALUE. 变化范围初始值±30%。 (5) WITHOUT DAMAGE TO PARTS ARCING OR BREAKDOWN ETC. (测试后外表无损伤,并且满足机械性能)</p>	
6、2	SOLDERABILITY TEST 可焊性试验	<p>THE TOP OF THE TERMINALS SHALL BE DIPPED 2mm IN THE SOLDER BATH OF 200±5℃, 时间为3±0.5秒。</p>		<p>THE AREA OF SOLDERING. SHOULD BE OVER 75%. 焊接面积要有75%以上。</p>	
6、3	RESISTANCE TO SOLDERING HEAT TEST 耐焊性试验	<p>SOLDER BATH METHOD: SOLDER TEMPERATURE 230±5℃ IMMERSION TIME 3±0.5 SEC IMMERSION DEPTH UP TO THE SURFACE OF THE BOARD THICKNESS OF PRINTED WIRING BOARD 1.6 mm DIMENSIONS OFCOMPONENT HOLES IN THE PRINTED WIRING BOARD SHALL BEING ACCORDANCE WITH THOSE SPECIFIED IN THIS SPECIFICATION. 焊炉焊接的时候温度控制在 230±5℃, 过炉时间3±0.5秒, 于(基板)厚度为1.6mm.</p>		<p>WITHOUT DEFORMATION OF CASE OR EXCESSIVE LOOSENESS OF TEMINALS ELECTRICAL CHARACTERISTICS SHALL BE SATISFIED. 本体无变形, 能满足于机械 电器性能。</p>	
6、4	COLD TEST 耐冷试验	<p>THE SWITCH SHALL BE STORED AT A TEMPERATURE OF -25±3℃ FOR 48 HOURS. THEN THE SWITCH SHALL BE MAINTAINED AT STANDARD ATMOSPHERIC CONDITIONS FOR 1 HOUR AFTER WHICH MEASUREMENT SHAOO BE MADE. 放置在温度-25±3℃中 48 小时后, 再放置常温常湿中1 小时来进行测试</p>		<p>THERE SHALL BE NO DEFORMATION OR CRACKS IN MOLDED PART. 外观无异常, 满足于机械`电器性能。</p>	
编写PREPARED BY		审核CHECKED BY	批准 APPROVED BY		
陈翠兰		邓振理	邓祝用		
			← 受控副本印章 CONTROL COPY CHOP		

Shenzhen Gangyuan Industry Development Co.,Ltd		文件编号 SPC NO	SS12F001	版本 VERSION	A
深圳市港源实业发展有限公司		页数 PAGE	3	共 OF	3
SPECIFICATION 规格书		日期 DATE: 2012-6-27			
6.5	HEAT TEST 耐热试验	<p>THE SWITCH SHALL BE STORED AT A TEMPERATURE OF 70±2°C FOR 48 HOURS. THEN THE SWITCH SHALL BE MAINTAINED AT STANDARD ATMOSPHERIC CONDITIONS FOR 1 HOUR AFTER WHICH MEASUREMENT SHALL BE MADE.</p> <p>放置在温度 70±2°C 中测试 48 小时后,再放置正常室温中 1 小时来测定.</p>		<p>THERE SHALL BE NO DEFORMATION OR CRACKS IN MOLDED PART.</p> <p>外观无异常,满足于机械`电器性能。</p>	
6.6	HUMIDITY TEST 潮湿试验	<p>THE SWITCH SHALL BE STORED AT A TEMPERATURE OF 40±2°C AND A HUMIDITY OF 90% TO 95% FOR 96 HOURS. THEN THE SWITCH SHALL BE MAINTAINED AT STANDARD ATMOSPHERIC CONDITION FOR 1 HOUR AFTER WHICH MEASUREMENT SHALL BE MADE.</p> <p>放置 40±2°C 的相对湿度为 90%~95% 环境中 96 小时后,再将样版放在正常环境 1 小时后进行测试.</p>			
6.7	STANDARD ATMOSPHERIC 测试标准状态	<p>UNLESS OTHERWISE SPECIFIED. THE STANDARD RANGE OF ATMOSPHERIC CONDITIONS FOR MAKING MEASUREMENTS AND TESTS ARE AS FOLLOWS:</p> <p>(1) AMBIENT TEMPERATURE : 5°C TO 35°C (2) RELATIVE HUMIDITY : 45% TO 85% (3) AIR PRESSURE : 86kpa TO 106Kpa</p> <p>在没有指定的情况下测试温度、湿度、气压如下:</p> <p>(1) 温度为 5~35°C. (2) 湿度为 45%~85%. (3) 气压为 86kpa~106kpa.</p>			
6.8	PRACTICAL TEMPERATURE RANGE 使用温度范围	<p>16°C~+60°C. 在 -16°C~+60°C 内使用.</p>			
编写 PREPARED BY		审核 CHECKED BY	批准 APPROVED BY	 受控副本印章 CONTROL COPY CHOP	
陈翠兰		邓振理	邓祝用		

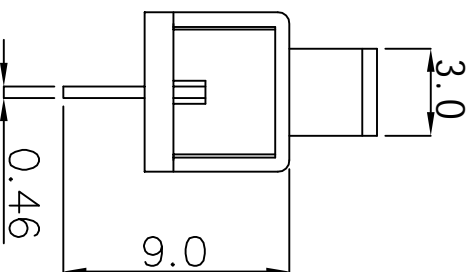
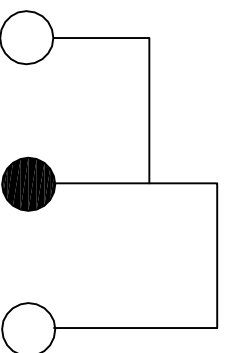
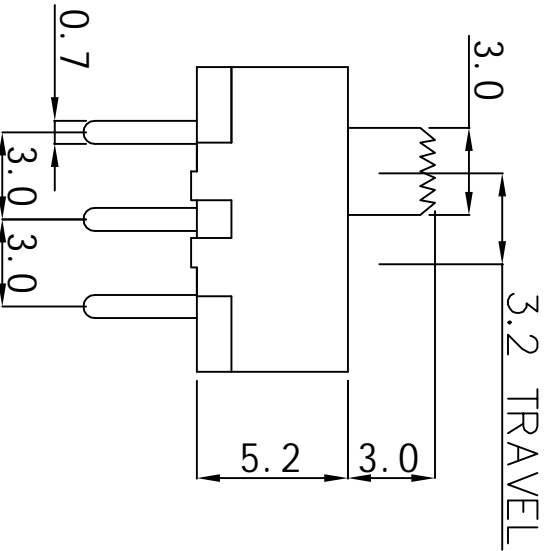
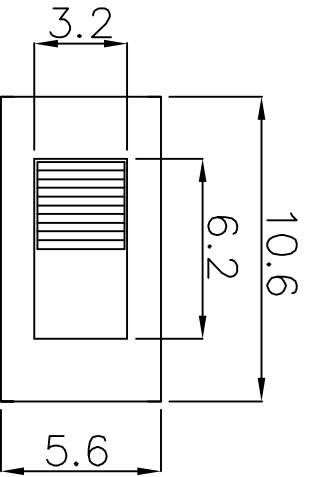

Shenzhen Gangyuan Industry Development Co., Ltd
深圳市港源实业发展有限公司

6	SPRING	PRESSURE SPRING COIL	1	TEMPER	TITLE: SLIDE SWITCH(1P2T)		UNIT: MM	TOLERANCE	
5	BOTTOM SHEET	KB-5252	1	NATURAL	MODEL NO: SS12F17-G3针脚		SCALE: 2:1	ANGLE:	±3
4	KNOB	POM	1	G2-15	DRAWN: 陈翠兰		DATE: 2012-6-27	ABOVE 0--10:	±0.2
3	CONTACT CLIP	OSM6.5-0.1	1	AG PLATED	CHECKED: 邓振理		DATE: 2012-6-27	ABOVE 10--60:	±0.3
2	TERMINAL	BRASS	3	AG PLATED	APPROVED: 邓祝用		DATE: 2012-6-27		
1	FRAME	SPCC	1	NI PLATED			DATE: 2012-6-27		
NO	PART NAME	MATERIAL	QTY	REMARKS					

单击下面可查看定价，库存，交付和生命周期等信息

[>>Gangyuan\(港源\)](#)