

**GT24C32D**

---



**Advanced**

**GT24C32D**

**2-WIRE**

**32K Bits**

**Serial EEPROM**

# GT24C32D



## 32Kb 2-Wire Serial EEPROM

Advanced

### Table of Contents

1. Features	3
2. General Description	3
3. Functional Block Diagram	4
4. Pin Configuration	5
4.1 8-Pin SOIC, TSSOP, MSOP and PDIP	5
4.2 8-Lead UDFN and XDFN	5
4.3 5-Lead SOT23	5
4.4 Pin Definition	6
4.5 Pin Descriptions	6
5. Device Operation	7
5.1 2-WIRE Bus	7
5.2 The Bus Protocol	7
5.3 Start Condition	8
5.4 Stop Condition	8
5.5 Acknowledge	8
5.6 Reset	8
5.7 Standby Mode	8
5.8 Device Addressing	8
5.9 Write Operation	9
5.10 Read Operation	10
5.11. Timing Diagrams	12
6. Electrical Characteristics	12
6.1 Absolute Maximum Ratings	12
6.2 Operating Range	13
6.3 Capacitance	13
6.4 Power Up/Down and Voltage Drop	13
6.5 DC Electrical Characteristic	14
6.6 AC Electrical Characteristic	15
7. Ordering Information	16
8. Top Markings	17
8.1 SOIC package	17
8.2 TSSOP package	17
8.3 PDIP package	17
8.4 UDFN package	17
8.5 MSOP Package	18
8.6 XDFN Package	18
8.7 SOT23 Package	18
9. Package Information	19
9.1 SOIC	19
9.2 TSSOP	20
9.3 PDIP	21
9.4 UDFN	22
9.5 MSOP	23
9.6 XDFN	24
9.7 SOT23	25
10. Revision History	26



# GT24C32D

## 1. Features

- Two-Wire Serial Interface, I<sup>2</sup>C™ Compatible
  - Bi-directional data transfer protocol
- Wide-voltage Operation
  - V<sub>CC</sub> = 1.65V to 5.5V
- Speed: 1 MHz ( 1.65V~5.5V)
- Standby current (max.): 1 μA, 5.5V
- Read current (max.): 0.5 mA, 5.5V
- Write current (max.): 0.5 mA, 5.5V
- Hardware Data Protection
  - Write Protect Pin
- Sequential & Random Read Features
- Memory organization: 32Kb (4,096 x 8)
- Page Size: 32 bytes
- Page write mode
  - Partial page writes allowed
- Self timed write cycle: 5 ms (max.)
- Noise immunity on inputs, besides Schmitt trigger
- High-reliability
  - Endurance: 1 million cycles
  - Data retention: 100 years
- ESD Protection > 4000V
- Industrial grade
- Packages: SOIC, TSSOP, PDIP, UDFN, MSOP, XDFN and SOT23
- Lead-free, RoHS, Halogen free, Green

## 2. General Description

The GT24C32D is an industrial standard electrically erasable programmable read only memory (EEPROM) device that utilizes the industrial standard 2-wire interface for communications. The GT24C32D contains a memory array of 32K bits (4,096x8), which is organized in 32-byte per page.

The EEPROM operates in a wide voltage range from 1.65V to 5.5V, which fits most application. The product provides low-power operations and low standby current. The device is offered in Lead-free, RoHS, halogen free or Green package. The available package types are 8-pin SOIC, TSSOP, PDIP, UDFN, MSOP, XDFN and SOT23.

The GT24C32D is compatible to the standard 2-wire bus protocol. The simple bus consists of Serial Clock (SCL) and Serial Data (SDA) signals. Utilizing such bus protocol, a Master device, such as a microcontroller, can usually control one or more Slave devices, alike this GT24C32D. The bit stream over the SDA line includes a series of bytes, which identifies a particular Slave device, an instruction, an address within that Slave device, and a series of data, if appropriate. The GT24C32D also has a Write Protect function via WP pin to cease from overwriting the data

stored inside the memory array.

In order to refrain the state machine from entering into a wrong state during power-up sequence or a power toggle off-on condition, a power on reset circuit is embedded. During power-up, the device does not respond to any instructions until the supply voltage (V<sub>CC</sub>) has reached an acceptable stable level above the reset threshold voltage. Once V<sub>CC</sub> passes the power on reset threshold, the device is reset and enters into the Standby mode. This would also avoid any inadvertent Write operations during power-up stage. During power-down process, the device will enter into standby mode, once V<sub>CC</sub> drops below the power on reset threshold voltage. In addition, the device will be in standby mode after receiving the Stop command, provided that no internal write operation is in progress. Nevertheless, it is illegal to send a command unless the V<sub>CC</sub> is within its operating level.



## 3. Functional Block Diagram

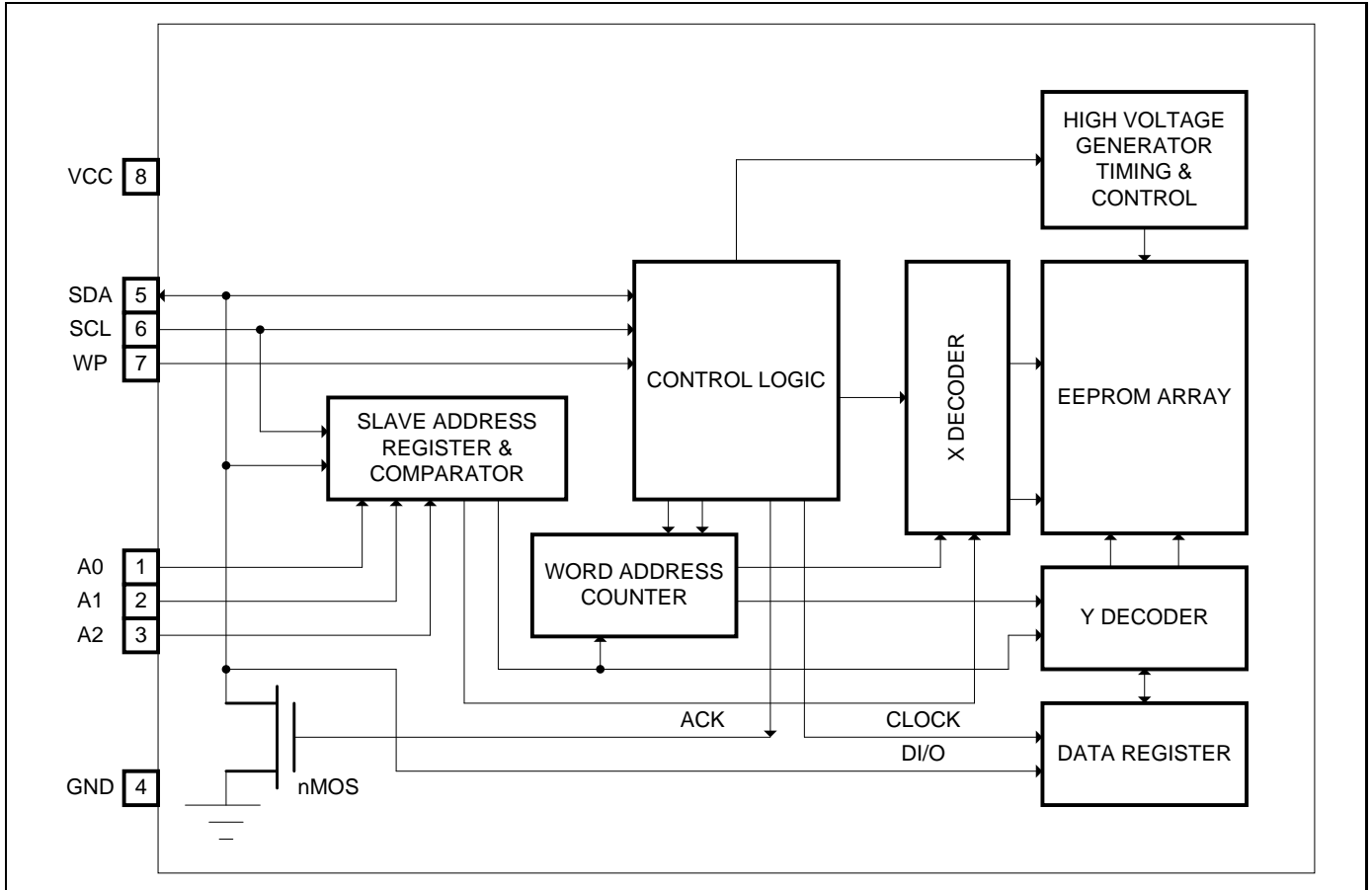



# GT24C32D

## 4. Pin Configuration

### 4.1 8-Pin SOIC, TSSOP, MSOP and PDIP

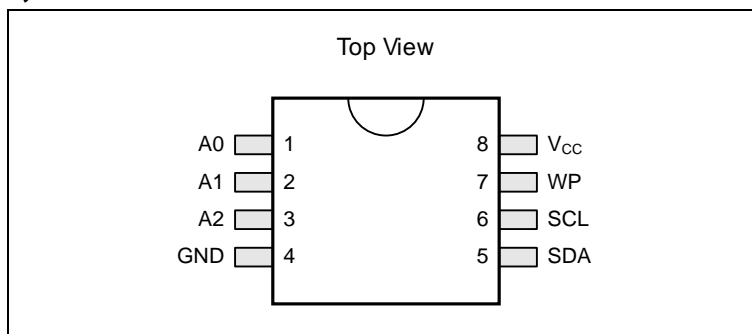

### 4.2 8-Lead UDFN and XDFN

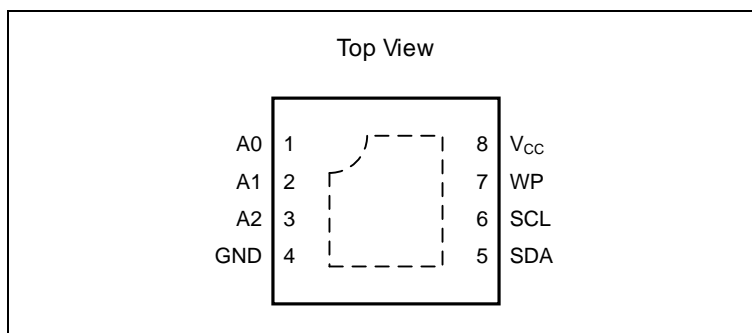

### 4.3 5-Lead SOT23

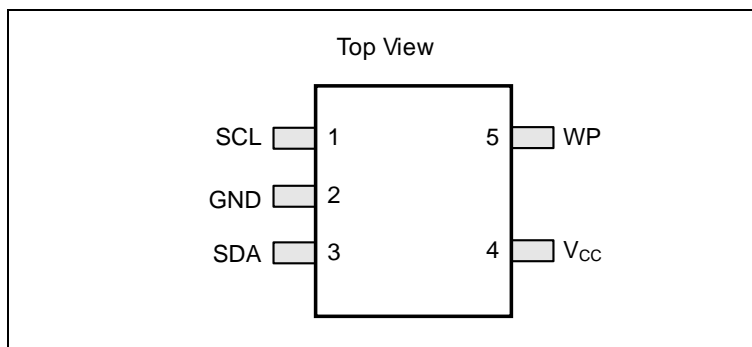



# GT24C32D

## 4.4 Pin Definition

Pin No.	Pin Name	I/O	Definition
1	A0	I	Device Address Input
2	A1	I	Device Address Input
3	A2	I	Device Address Input
4	GND	-	Ground
5	SDA	I/O	Serial Address, Data input and Data output
6	SCL	I	Serial Clock Input
7	WP	I	Write Protect Input
8	V <sub>cc</sub>	-	Power Supply

## 4.5 Pin Descriptions

### SCL

This input clock pin is used to synchronize the data transfer to and from the device.

### SDA

The SDA is a bi-directional pin used to transfer addresses and data into and out of the device. The SDA pin is an open drain output and can be wired with other open drain or open collector outputs. However, the SDA pin requires a pull-up resistor connected to the power supply.

### A0, A1, A2

The A0, A1 and A2 are the device address inputs.

Typically, the A0, A1, and A2 pins are for hardware addressing and a total of 8 devices can be connected on a single bus system. When A0, A1, and A2 are left floating, the inputs are defaulted to zero.

### WP

WP is the Write Protect pin. While the WP pin is connected to the power supply of GT24C32D, the entire array becomes Write Protected (i.e. the device becomes Read only). When WP is tied to Ground or left floating, the normal write operations are allowed.

### V<sub>cc</sub>

Supply voltage

### GND

Ground of supply voltage

### Note:

More detail application information, please check application note.

Application note : <http://www.giantec-semi.com/Application-note.html>



# GT24C32D

## 5. Device Operation

The GT24C32D serial interface supports communications using industrial standard 2-wire bus protocol, such as I<sup>2</sup>C.

### 5.1 2-WIRE Bus

The two-wire bus is defined as Serial Data (SDA), and Serial Clock (SCL). The protocol defines any device that sends data onto the SDA bus as a transmitter, and the receiving devices as receivers. The bus is controlled by Master device that generates the SCL, controls the bus access, and generates the Start and Stop conditions. The GT24C32D is the Slave device.

**Figure 1. Typical System Bus Configuration**

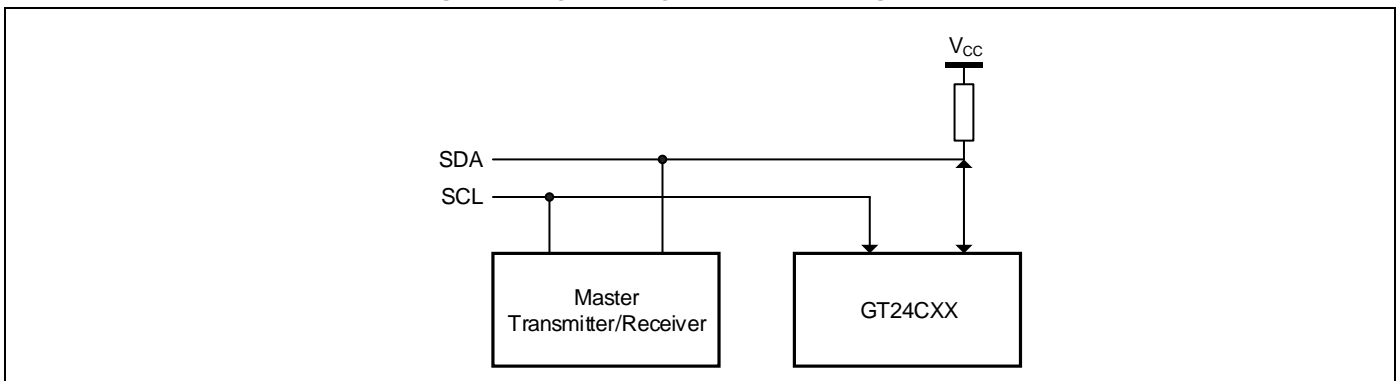

### 5.2 The Bus Protocol

Data transfer may be initiated only when the bus is not busy. During a data transfer, the SDA line must remain stable whenever the SCL line is high. Any changes in the SDA line while the SCL line is high will be interpreted as a Start or Stop condition.

The state of the SDA line represents valid data after a Start condition. The SDA line must be stable for the duration of the High period of the clock signal. The data on the SDA line may be changed during the Low period of the clock signal. There is one clock pulse per bit of data. Each data transfer is initiated with a Start condition and terminated by a Stop condition.

**Figure 2. Data Validity Protocol**

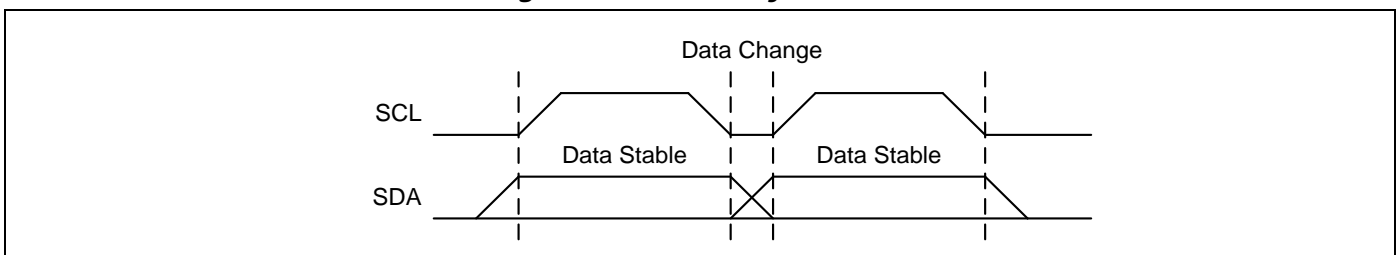



# GT24C32D

## 5.3 Start Condition

The Start condition precedes all commands to the device and is defined as a High to Low transition of SDA when SCL is High. The EEPROM monitors the SDA and SCL lines and will not respond until the Start condition is met.

Figure 3. Start and Stop Conditions

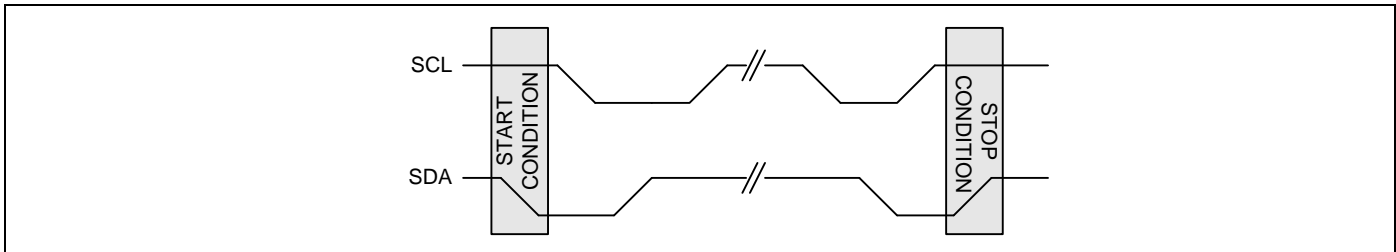

## 5.4 Stop Condition

The Stop condition is defined as a Low to High transition of SDA when SCL is High. All operations must end with a Stop condition.

## 5.5 Acknowledge

After a successful data transfer, each receiving device is required to generate an ACK. The Acknowledging device pulls down the SDA line.

Figure 4. Output Acknowledge

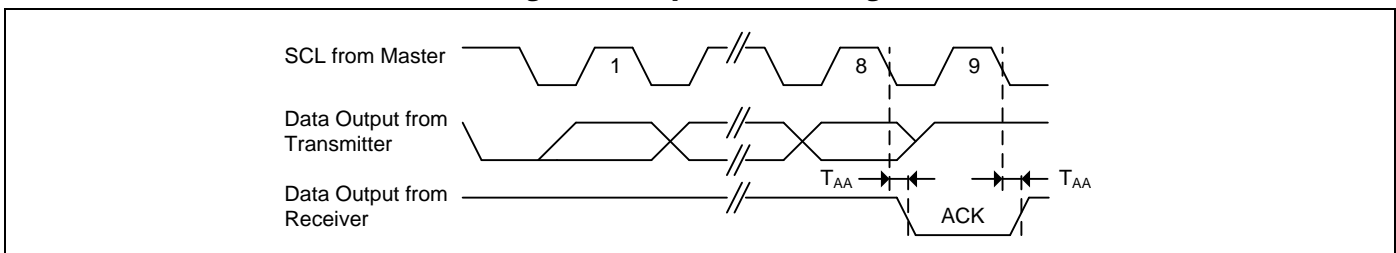

## 5.6 Reset

The GT24C32D contains a reset function in case the 2-wire bus transmission on is accidentally interrupted (e.g. a power loss), or needs to be terminated mid-stream. The reset is initiated when the Master device creates a Start condition. To do this, it may be necessary for the Master device to monitor the SDA line while cycling the SCL up to nine times. (For each clock signal transition to High, the Master checks for a High level on SDA.)

## 5.7 Standby Mode

While in standby mode, the power consumption is minimal. The GT24C32D enters into standby mode during one of the following conditions: a) After Power-up, while no Op-code is sent; b) After the completion of an operation and followed by the Stop signal, provided that the previous operation is not Write related; or c) After the completion of any internal write operations.

## 5.8 Device Addressing

The Master begins a transmission on by sending a Start condition, then sends the address of the particular Slave devices to be communicated. The Slave device address is 8 bits format as shown in Figure. 5-5.

The four most significant bits of the Slave address are fixed (1010) for GT24C32D.

The next three bits, A0, A1 and A2, of the Slave address are specifically related to EEPROM. Up to eight GT24C32D units can be connected to the 2-wire bus.

The last bit of the Slave address specifies whether a Read or Write operation is to be performed. When this bit is set to 1, Read





# GT24C32D

operation is selected. While it is set to 0, Write operation is selected.

After the Master transmits the Start condition and Slave address byte appropriately, the associated 2-wire Slave device, GT24C32D, will respond with ACK on the SDA line. Then GT24C32D will pull down the SDA on the ninth clock cycle, signaling that it received the eight bits of data.

The GT24C32D then prepares for a Read or Write operation by monitoring the bus.

**Figure 5. Slave Address**

Bit	7	6	5	4	3	2	1	0
	1	0	1	0	A2	A1	A0	R/W

## 5.9 Write Operation

### 5.9.1 Byte Write

In the Byte Write mode, the Master device sends the Start condition and the Slave address information (with the R/W set to Zero) to the Slave device. After the Slave generates an ACK, the Master sends the byte address that is to be written into the address pointer of the GT24C32D. After receiving another ACK from the Slave, the Master device transmits the data byte to be written into the address memory location. The GT24C32D acknowledges once more and the Master generates the Stop condition, at which time the device begins its internal programming cycle. While this internal cycle is in progress, the device will not respond to any request from the Master device.

**Figure 8. Byte Write**

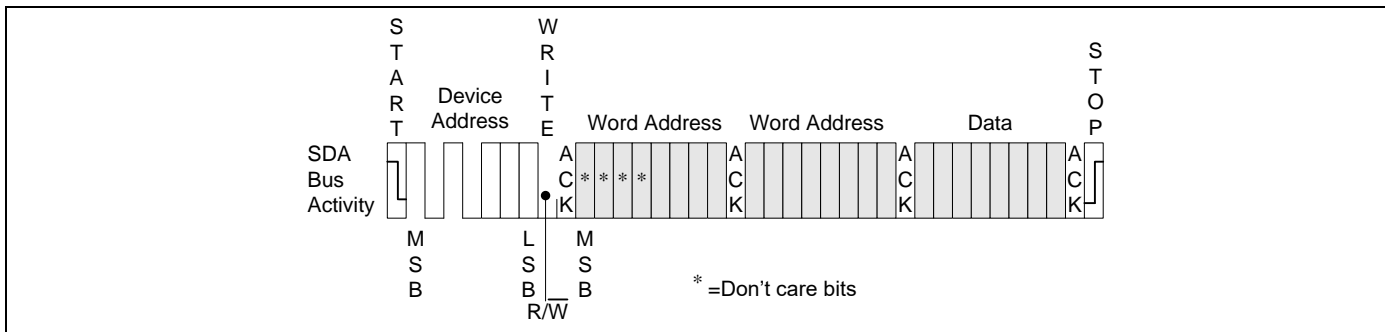

### 5.9.2 Page Write

The GT24C32D is capable of 32-byte Page-Write operation. A Page-Write is initiated in the same manner as a Byte Write, but instead of terminating the internal Write cycle after the first data word is transferred, the Master device can transmit up to 31 more bytes. After the receipt of each data word, the EEPROM responds immediately with an ACK on SDA line, and the five lower order data word address bits are internally incremented by one, while the higher order bits of the data word address remain constant. If a byte address is incremented from the last byte of a page, it returns to the first byte of that page. If the Master device should transmit more than 32 bytes prior to issuing the Stop condition, the address counter will "roll over," and the previously written data will be overwritten. Once all 32 bytes are received and the Stop condition has been sent by the Master, the internal programming cycle begins. At this point, all received data is written to the GT24C32D in a single Write cycle. All inputs are disabled until completion of the internal Write cycle.

**Figure 9. Page Write**

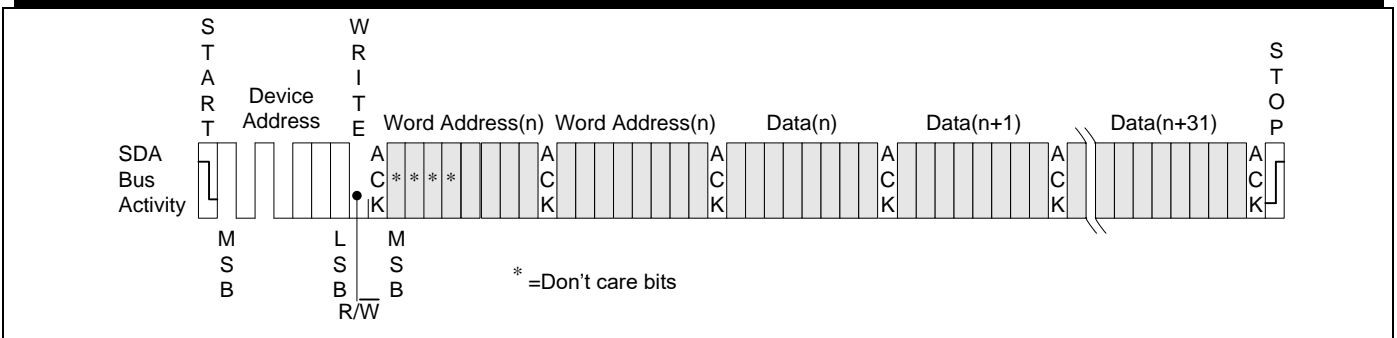

### 5.9.3 Acknowledge (ACK) Polling

The disabling of the inputs can be used to take advantage of the typical Write cycle time. Once the Stop condition is issued to indicate the end of the host's Write operation, the GT24C32D initiates the internal Write cycle. ACK polling can be initiated immediately. This involves issuing the Start condition followed by the Slave address for a Write operation. If the EEPROM is still busy with the Write operation, no ACK will be returned. If the GT24C32D has completed the Write operation, an ACK will be returned and the host can then proceed with the next Read or Write operation.

### 5.10 Read Operation

Read operations are initiated in the same manner as Write operations, except that the (R/W) bit of the Slave address is set to "1". There are three Read operation options: current address read, random address read and sequential read.

#### 5.10.1 Current Address Read

The GT24C32D contains an internal address counter which maintains the address of the last byte accessed, incremented by one. For example, if the previous operation is either a Read or Write operation addressed to the address location n, the internal address counter would increment to address location n+1. When the EEPROM receives the Slave Addressing Byte with a Read operation (R/W bit set to "1"), it will respond an ACK and transmit the 8-bit data byte stored at address location n+1. The Master should not acknowledge the transfer but should generate a Stop condition so the GT24C32D discontinues transmission. If 'n' is the last byte of the memory, the data from location '0' will be transmitted. (Refer to Figure 10. Current Address Read Diagram.)

**Figure 10. Current Address Read**

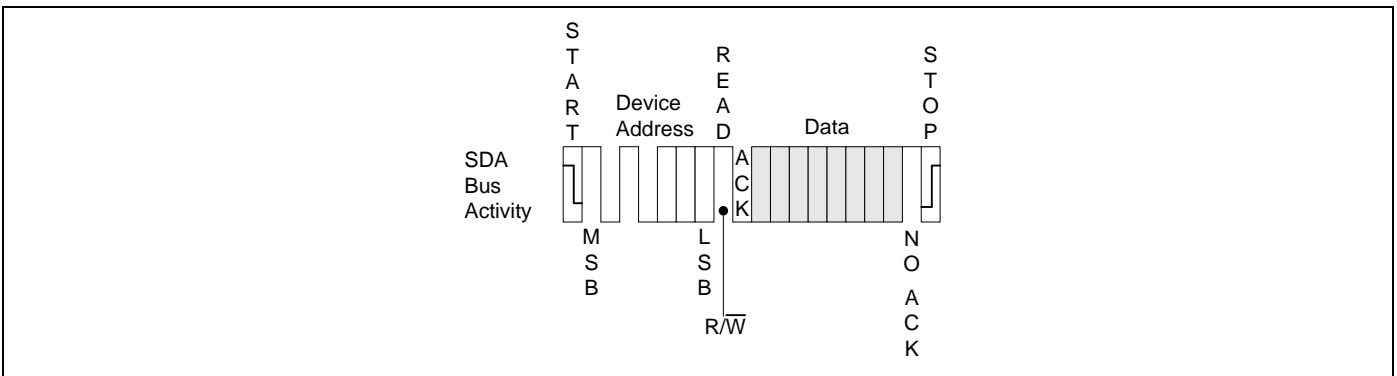



## 5.10.2 Random Address Read

Selective Read operations allow the Master device to select at random any memory location for a Read operation. The Master device first performs a 'dummy' Write operation by sending the Start condition, Slave address and byte address of the location it wishes to read. After the GT24C32D acknowledges the byte address, the Master device resends the Start condition and the Slave address, this time with the R/W bit set to one. The EEPROM then responds with its ACK and sends the data requested. The Master device does not send an ACK but will generate a Stop condition. (Refer to Figure 11. Random Address Read Diagram.)

Figure 11. Random Address Read

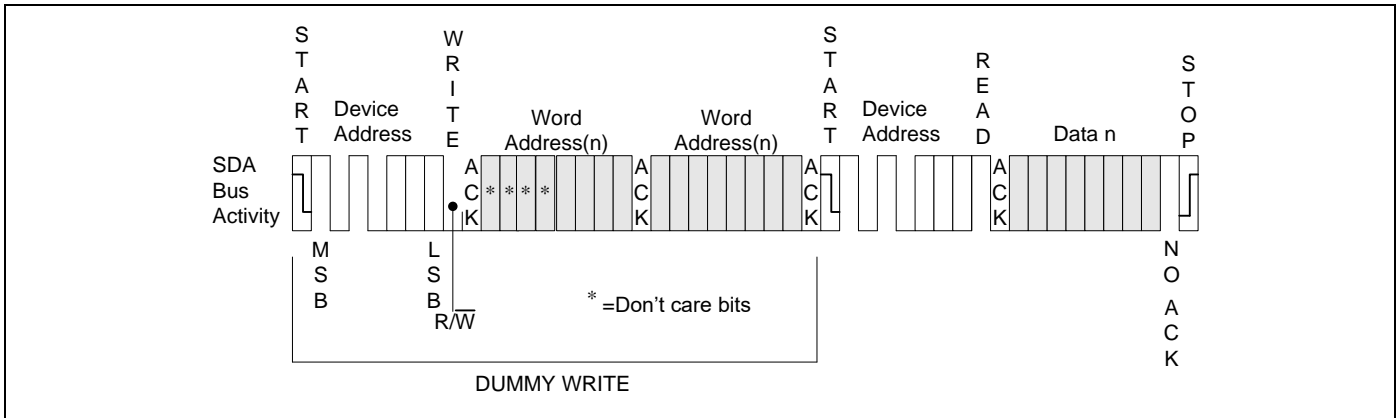

## 5.10.3 Sequential Read

Sequential Reads can be initiated as either a Current Address Read or Random Address Read. After the GT24C32D sends the initial byte sequence, the Master device now responds with an ACK indicating it requires additional data from the GT24C32D. The EEPROM continues to output data for each ACK received. The Master device terminates the sequential Read operation by pulling SDAHigh (no ACK) indicating the last data word to be read, followed by a Stop condition. The data output is sequential, with the data from address n followed by the data from address n+1, n+2 ... etc. The address counter increments by one automatically, allowing the entire memory contents to be serially read during sequential Read operation. When the memory address boundary of the array is reached, the address counter "rolls over" to address 0, and the device continues to output data. (Refer to Figure 12. Sequential Read Diagram).

Figure 12. Sequential Read

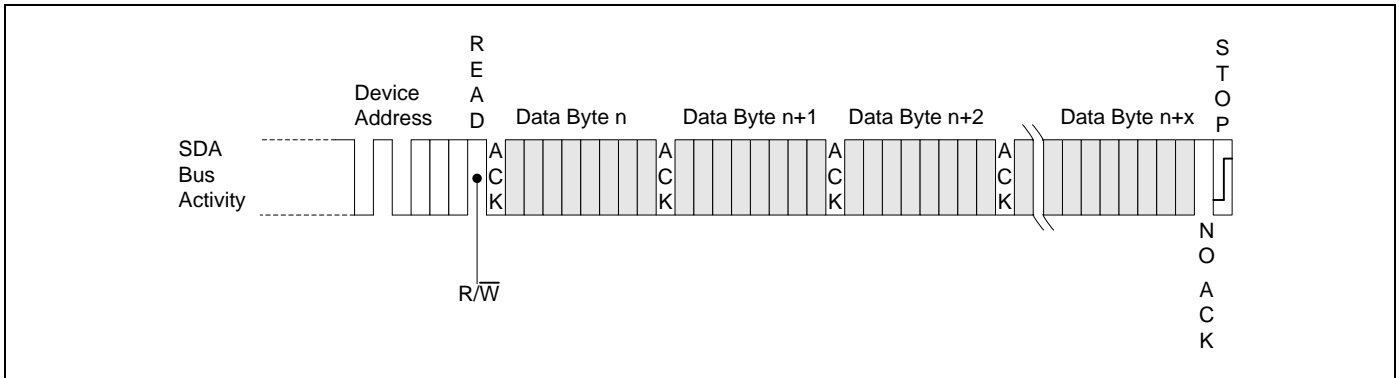

## 5.11. Timing Diagrams

Figure 5-11. Bus Timing

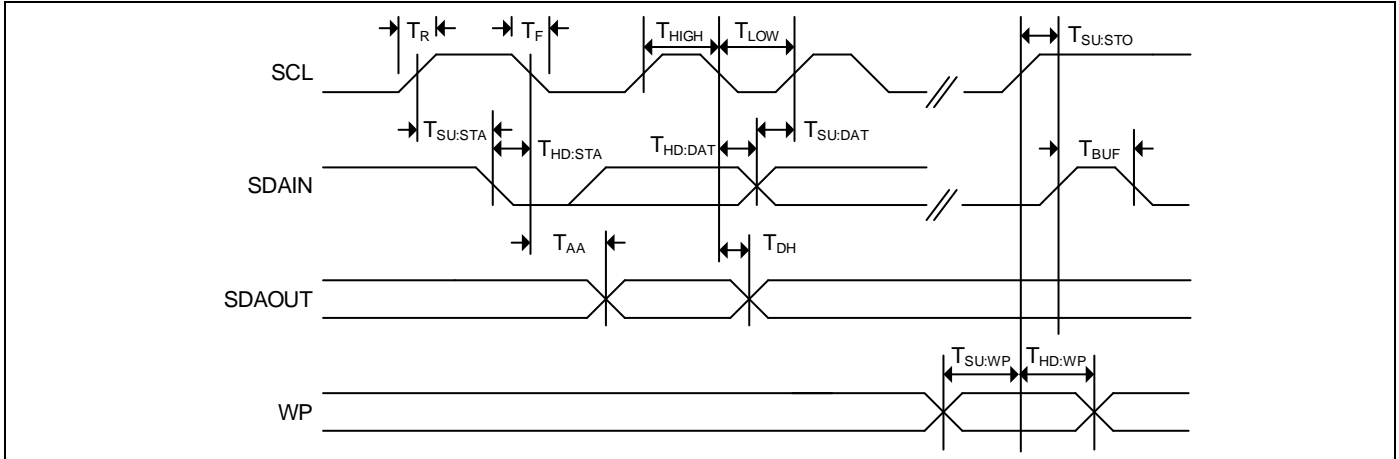
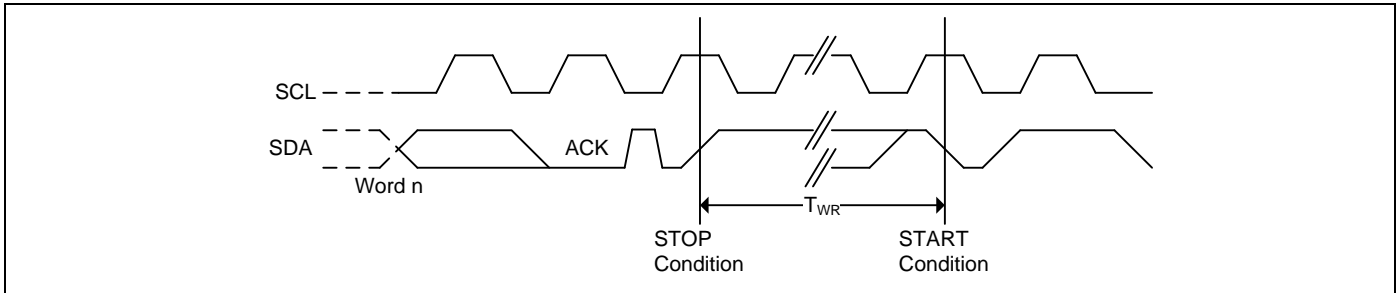

Figure 5-12. Write Cycle Timing



## 6. Electrical Characteristics

### 6.1 Absolute Maximum Ratings

Symbol	Parameter	Value	Unit
$V_S$	Supply Voltage	-0.5 to + 6.5	V
$V_P$	Voltage on Any Pin	-0.5 to + 6.5	V
$T_{BIAS}$	Temperature Under Bias	-55 to +125	°C
$T_{STG}$	Storage Temperature	-65 to +150	°C
$I_{OUT}$	Output Current	5	mA

Note: Stress greater than those listed under Absolute Maximum Ratings may cause permanent damage to the device. This is a stress rating only and functional operation of the device at these or any other condition outside those indicated in the operational sections of this specification is not implied. Exposure to absolute maximum rating conditions for extended periods may affect reliability.



# GT24C32D

## 6.2 Operating Range

Range	Ambient Temperature (T <sub>A</sub> )	V <sub>CC</sub>
Industrial	-40°C to +85°C	1.65V to 5.5V

Note: Giantec offers Industrial grade for Commercial applications (0°C to +70°C).

## 6.3 Capacitance

Symbol	Parameter <sup>[1, 2]</sup>	Conditions	Max.	Unit
C <sub>IN</sub>	Input Capacitance	V <sub>IN</sub> = 0V	6	pF
C <sub>I/O</sub>	Input / Output Capacitance	V <sub>I/O</sub> = 0V	8	pF

Notes: <sup>[1]</sup> Tested initially and after any design or process changes that may affect these parameters and not 100% tested.

<sup>[2]</sup> Test conditions: T<sub>A</sub> = 25°C, f = 1 MHz, V<sub>CC</sub> = 5.0V.

## 6.4 Power Up/Down and Voltage Drop

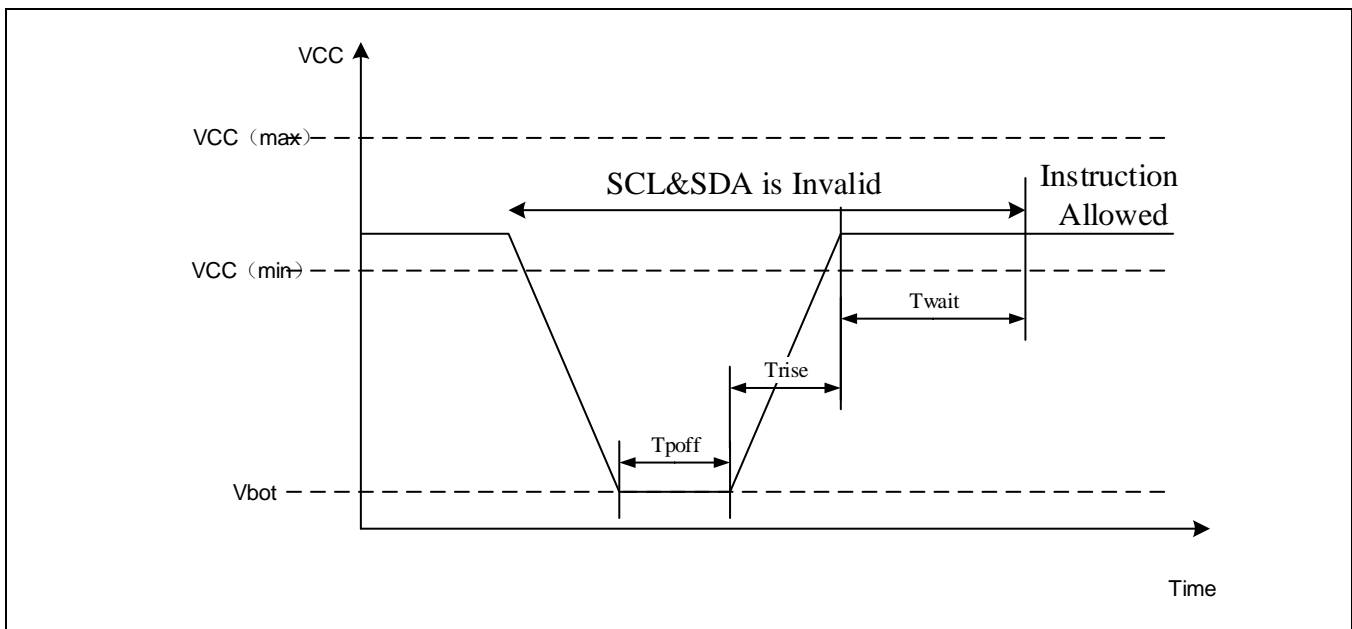

Power down-up Timing

Symbol	Parameter	min	max	unit
V <sub>bot</sub>	VCC at power off		0.2	V
T <sub>poff</sub>	VCC at power off time	100		ms
T <sub>rise</sub>	V <sub>bot</sub> to VCC min	0.01	5	ms
T <sub>wait</sub>	VCC Min to Instruction	1		ms

\* All parameters may be changed after the design or process change.



# GT24C32D

## 6.5 DC Electrical Characteristic

Industrial:  $T_A = -40^{\circ}\text{C}$  to  $+85^{\circ}\text{C}$ ,  $V_{CC} = 1.65\text{V} \sim 5.5\text{V}$

Symbol	Parameter [1]	V <sub>CC</sub>	Test Conditions	Min.	Typ.	Max.	Unit
V <sub>CC</sub>	Supply Voltage			1.65		5.5	V
V <sub>IH</sub>	Input High Voltage			0.7*V <sub>CC</sub>		V <sub>CC</sub> +1	V
V <sub>IL</sub>	Input Low Voltage			-0.5		0.3* V <sub>CC</sub>	V
I <sub>LI</sub>	Input Leakage Current	5 V	V <sub>IN</sub> = V <sub>CC</sub> max	—		2	μA
I <sub>LO</sub>	Output Leakage Current	5V		—		2	μA
V <sub>OL1</sub>	Output Low Voltage	1.65V	I <sub>OL</sub> = 0.15 mA	—		0.2	V
V <sub>OL2</sub>	Output Low Voltage	2.5V	I <sub>OL</sub> = 2.1 mA	—		0.4	V
I <sub>SB1</sub>	Standby Current	1.65V	V <sub>IN</sub> = V <sub>CC</sub> or GND	—	0.2	1	μA
I <sub>SB2</sub>	Standby Current	2.5V	V <sub>IN</sub> = V <sub>CC</sub> or GND	—	0.3	1	μA
I <sub>SB3</sub>	Standby Current	5.5V	V <sub>IN</sub> = V <sub>CC</sub> or GND	—	0.5	1	μA
I <sub>CC1</sub>	Read Current	1.65V	Read at 400 KHz	—		0.15	mA
		5.5V	Read at 1 MHz	—		0.5	mA
I <sub>CC2</sub>	Write Current	1.65V	Write at 400 KHz	—		0.5	mA
		1.65V	Write at 1 MHz	—		0.6	mA
		5.5V	Write at 1 MHz	—		0.8	mA

Note: The parameters are characterized but not 100% tested.



# GT24C32D

## 6.6 AC Electrical Characteristic

Industrial:  $T_A = -40^{\circ}\text{C}$  to  $+85^{\circ}\text{C}$ , Supply voltage = 1.65V to 5.5V

Symbol	Parameter <sup>[1]</sup> <sup>[2]</sup>	1.65V ≤ V <sub>CC</sub> ≤ 5.5V		Unit
		Min.	Max.	
F <sub>SCL</sub>	SCK Clock Frequency		1000	KHz
T <sub>LOW</sub>	Clock Low Period	600	—	ns
T <sub>HIGH</sub>	Clock High Period	400	—	ns
T <sub>R</sub>	Rise Time (SCL and SDA)	—	300	ns
T <sub>F</sub>	Fall Time (SCL and SDA)	—	100	ns
T <sub>SU:STA</sub>	Start Condition Setup Time	250	—	ns
T <sub>SU:STO</sub>	Stop Condition Setup Time	250	—	ns
T <sub>HD:STA</sub>	Start Condition Hold Time	250	—	ns
T <sub>SU:DAT</sub>	Data In Setup Time	100	—	ns
T <sub>HD:DAT</sub>	Data In Hold Time	0	—	ns
T <sub>AA</sub>	Clock to Output Access time (SCL Low to SDA Data Out Valid)	50	400	ns
T <sub>DH</sub>	Data Out Hold Time (SCL Low to SDA Data Out Change)	50	—	ns
T <sub>WR</sub>	Write Cycle Time	—	5	ms
T <sub>BUF</sub>	Bus Free Time Before New Transmission	400	—	ns
T <sub>SU:WP</sub>	WP pin Setup Time	600		ns
T <sub>HD:WP</sub>	WP pin Hold Time	400	—	ns
T	Noise Suppression Time	—	50	ns

Notes: <sup>[1]</sup>The parameters are characterized but not 100% tested.

<sup>[2]</sup> AC measurement conditions:

R<sub>L</sub> (connects to V<sub>CC</sub>): 1.3 kΩ (2.5V, 5.0V), 10 kΩ (1.65V)

C<sub>L</sub> = 100 pF

Input pulse voltages: 0.3\*V<sub>CC</sub> to 0.7\*V<sub>CC</sub>

Input rise and fall times: ≤ 50 ns

Timing reference voltages: half V<sub>CC</sub> level



# GT24C32D

## 7. Ordering Information

**Industrial Grade: -40°C to +85°C, Lead-free**

Voltage Range	Part Number*	Package
1.65V to 5.5V	GT24C32D-2GLI-TR	150-mil SOIC
	GT24C32D-2ZLI-TR	3 x 4.4 mm TSSOP
	GT24C32D-2UDLI-TR	2 x 3 x 0.55 mm UDFN
	GT24C32D-2PLI	300mil PDIP
	GT24C32D-2SLI-TR	3 x 3 mm MSOP
	GT24C32D-2XDLI-TR	1.8 x 2.2 x 0.4 mm XDFN
	GT24C32D-2TFLI-TR	2.9 x 1.6 mm SOT23

\*

1. Contact Giantec Sales Representatives for availability and other package information.
2. The product is packed in tape and reel "-TR" (4K per reel), except UDFN is 5K per reel, SOT23 is 3K per reel.
3. Refer to Giantec website for related declaration document on lead free, RoHS, halogen free or Green, whichever is applicable.
4. Giantec offers Industrial grade for Commercial applications (0°C to +70°C).





# GT24C32D

## 8. Top Markings

### 8.1 SOIC package

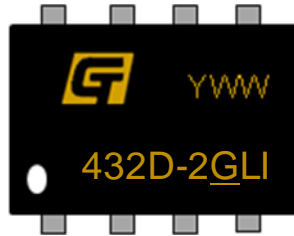

**G:** Giantec Logo  
432D-2GLI: GT24C32D-2GLI-TR  
YWW: Date Code, Y=year, WW=week

### 8.2 TSSOP package



**GT:** Giantec Logo  
432D-2ZLI: GT24C32D-2ZLI-TR  
YWW: Date Code, Y=year, WW=week

### 8.3 PDIP package

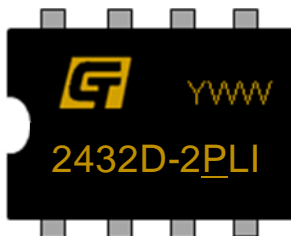

**GT:** Giantec Logo  
2432D-2PLI: GT24C32D-2PLI  
YWW: Date Code, Y=year, WW=week

### 8.4 UDFN package



**GT:** Giantec Logo  
45D: GT24C32D-2UDLI-TR  
YWW: Date Code, Y=year, WW=week



# GT24C32D

## 8.5 MSOP Package



**GT:** Giantec Logo

**432D2SU:** GT24C32D-2SLI-TR

**YWW:** Date Code, Y=year, WW=week

## 8.6 XDFN Package



**45D:** GT24C32D-2XDLI-TR

**YWW:** Date Code, Y=year, WW=week

## 8.7 SOT23 Package

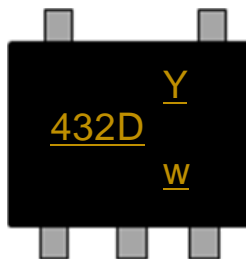

**432D:** GT24C32D-2TFLI-TR

**YW:** Date Code, Y=year, WW=week



# GT24C32D

## 9. Package Information

### 9.1 SOIC

#### 8L 150mil SOIC Package Outline

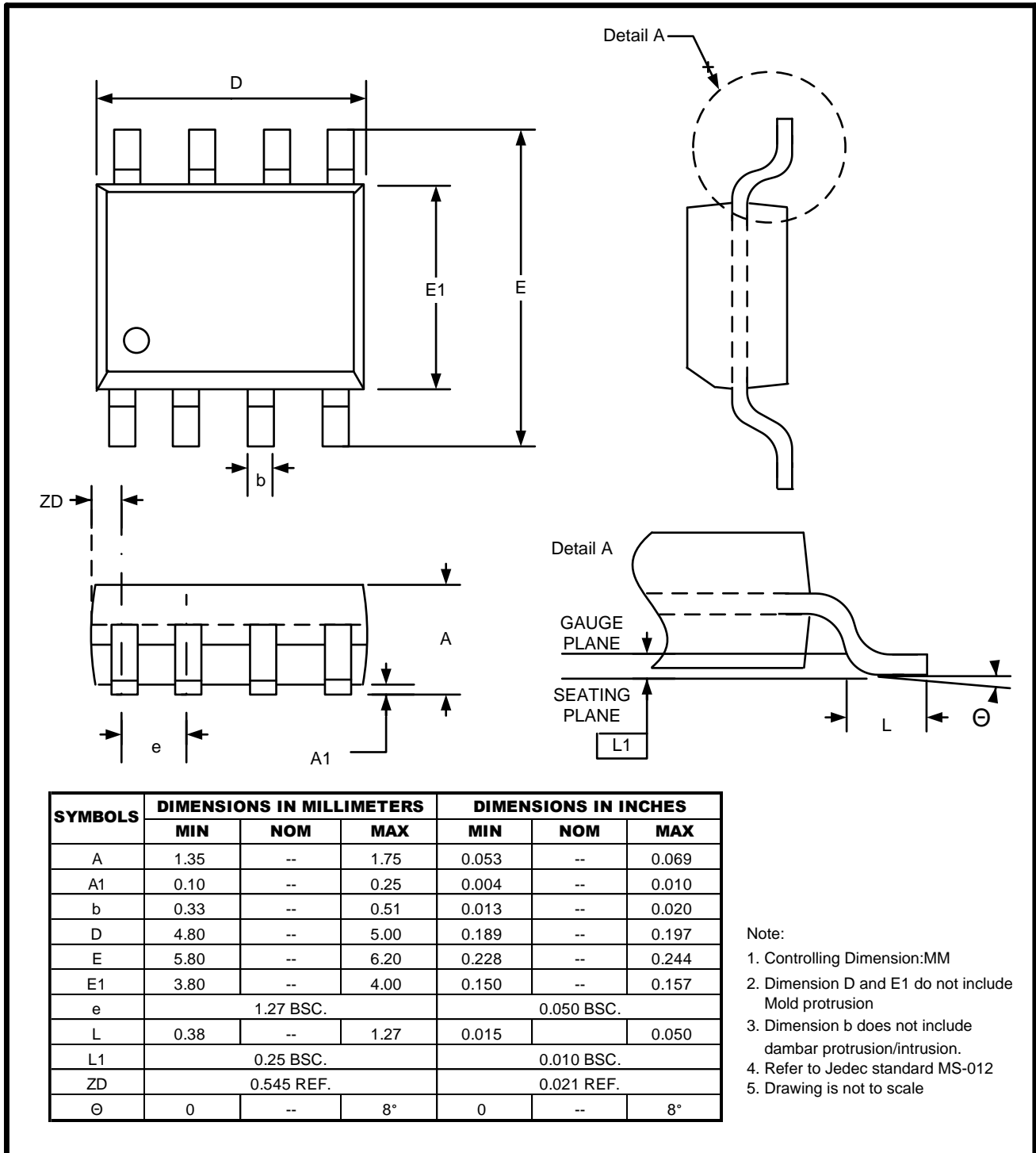



# GT24C32D

## 9.2 TSSOP

### 8L 3x4.4mm TSSOP Package Outline

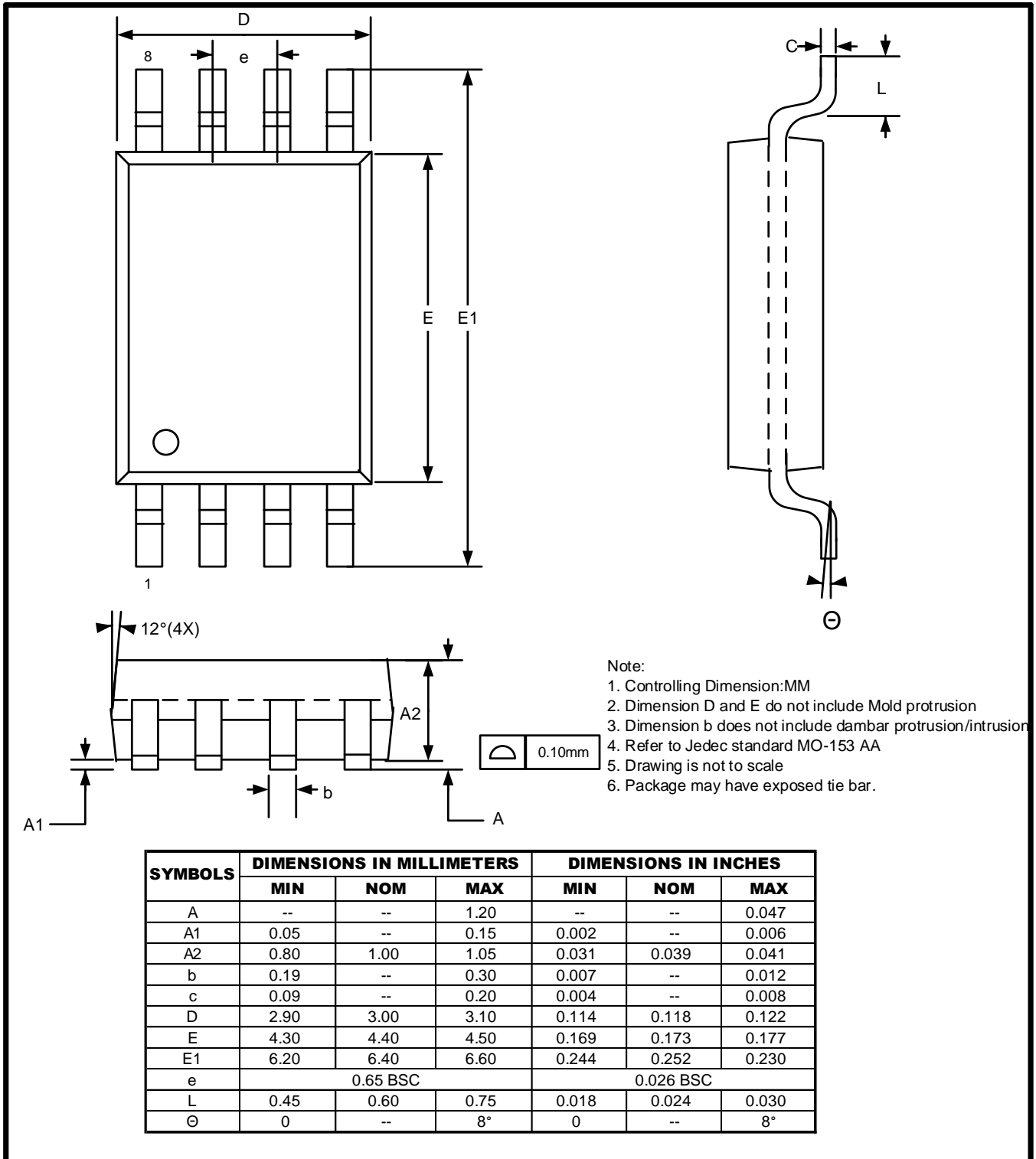



# GT24C32D

## 9.3 PDIP

### 8L 300mil PDIP Package Outline

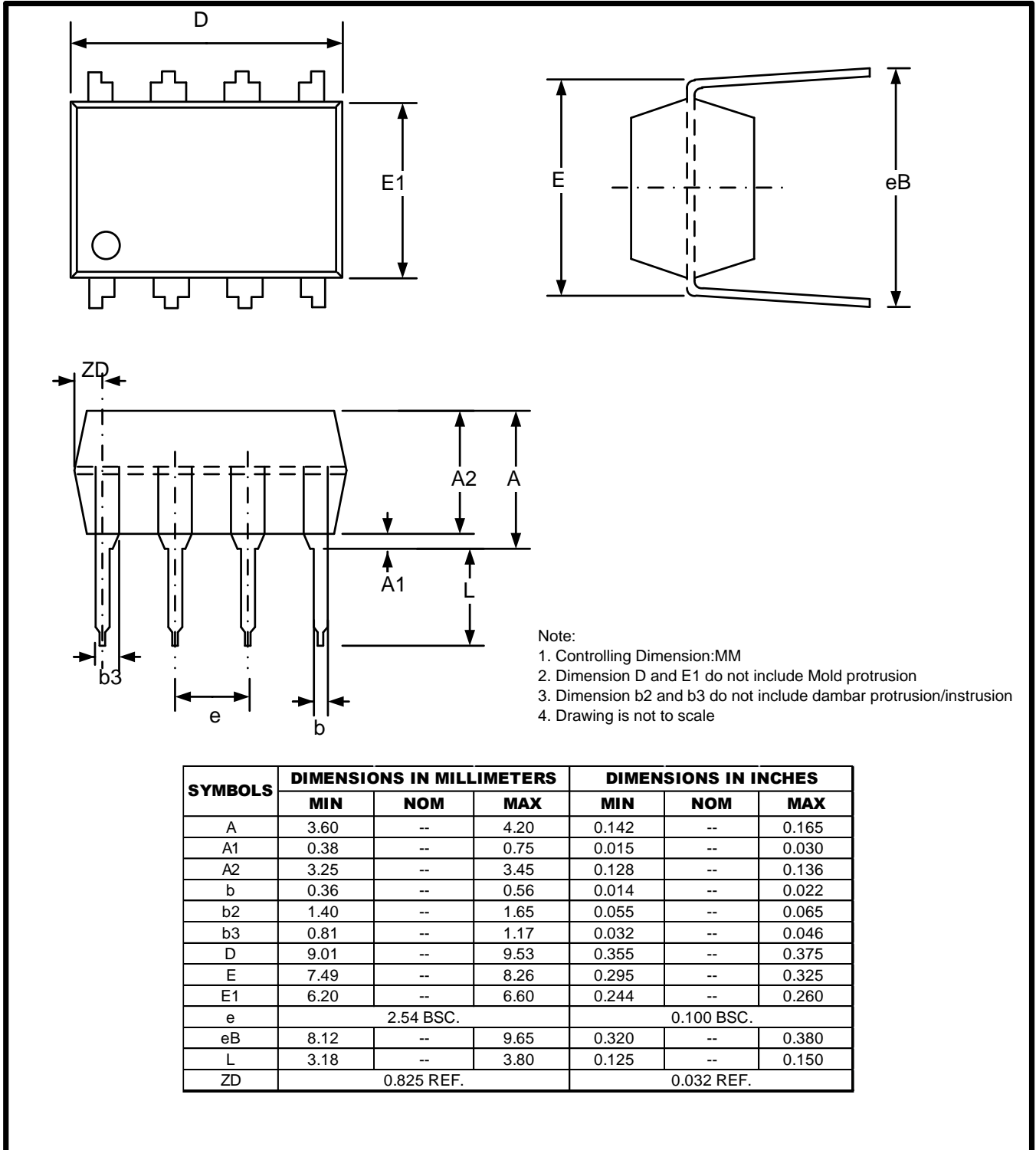

## 9.4 UDFN

### 8L 2x3mm UDFN Package Outline

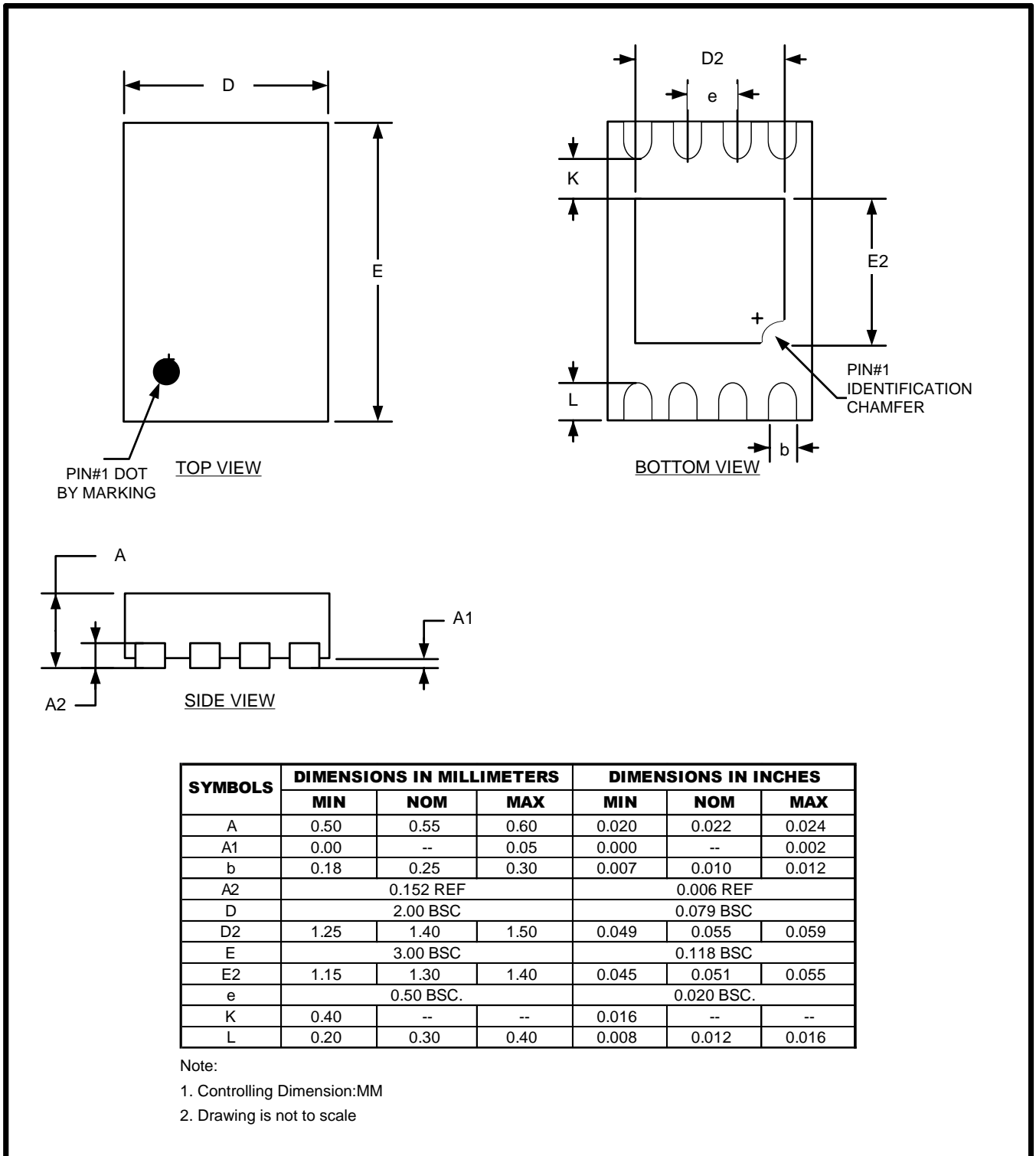



# GT24C32D

9.5 MSOP

## 8L 120mil MSOP package Outline

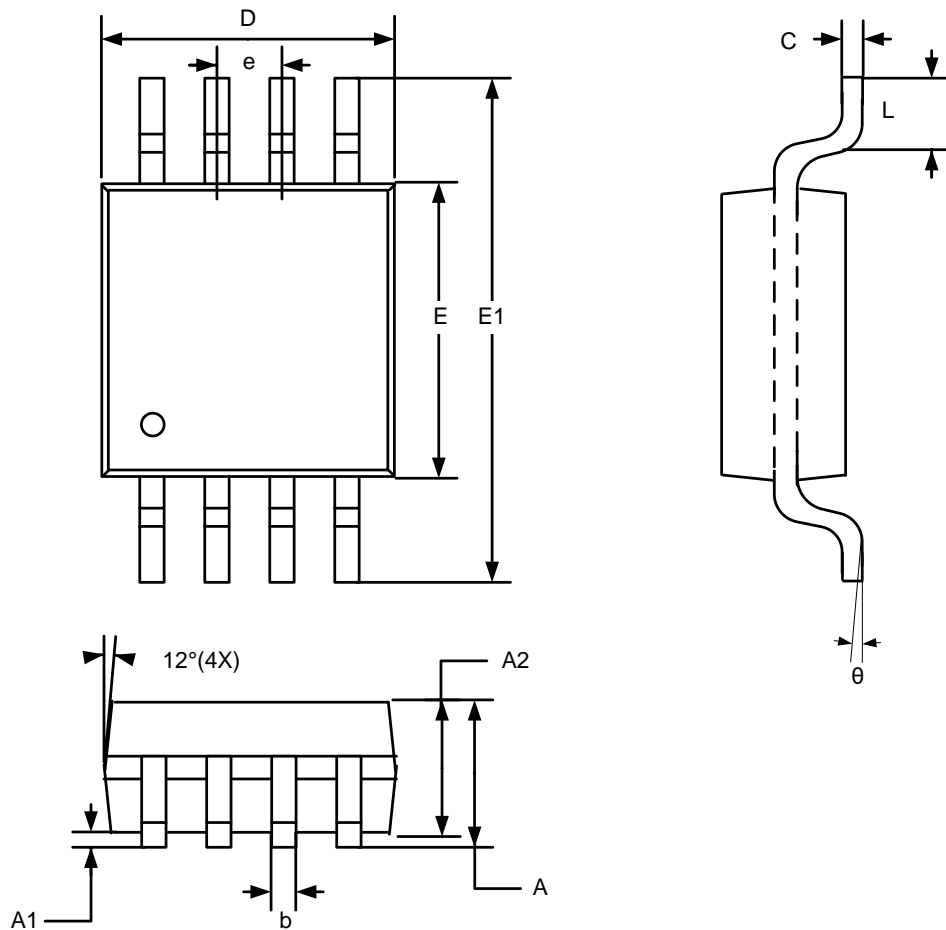

SYMBOLS	DIMENSIONS IN MILLIMETERS			DIMENSIONS IN INCHES		
	MIN	NOM	MAX	MIN	NOM	MAX
A	--	--	1.10	--	--	0.043
A1	0.05	--	0.15	0.002	--	0.006
A2	0.75	0.85	0.95	0.030	0.033	0.037
b	0.25	--	0.40	0.010	--	0.016
C	0.13	--	0.23	0.005	--	0.009
D	2.90	3.00	3.10	0.114	0.118	0.122
E	2.90	3.00	3.10	0.114	0.118	0.122
E1	4.90 BSC			0.193 BSC		
e	0.65 BSC			0.026 BSC		
L	--	--	0.55	--	--	0.022
Theta	0	--	7°	0	--	7°

Note:

1. Controlling Dimension:MM
2. Dimension D and E do not include Mold protrusion
3. Refer to Jedec standard MO187
4. Drawing is not to scale



# GT24C32D

## 9.6 XDFN

### 8L 1.8x2.2mm XDFN Package Outline

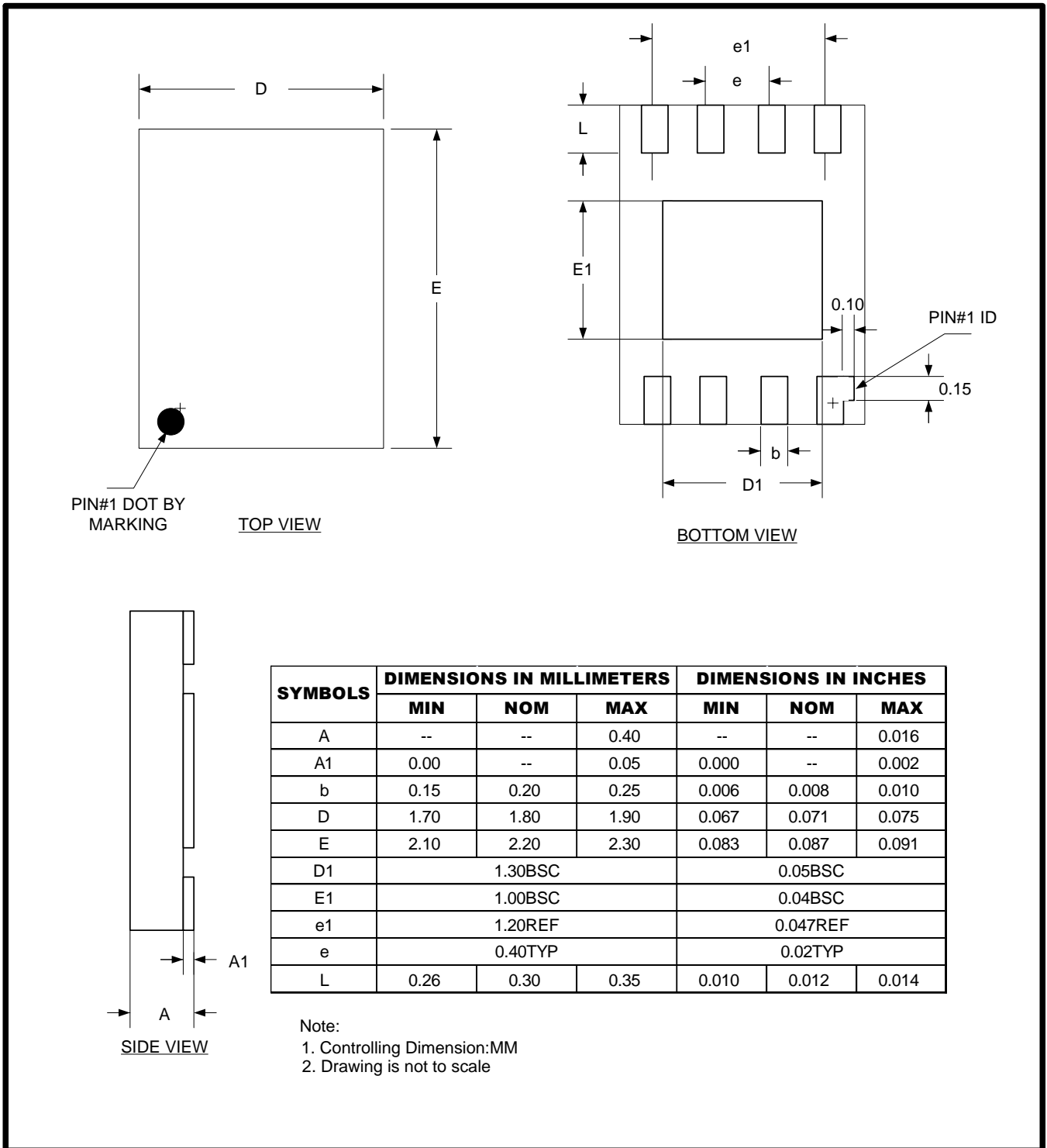





# GT24C32D

## 9.7 SOT23

### 5L 2.9x1.6mm SOT23 Package Outline

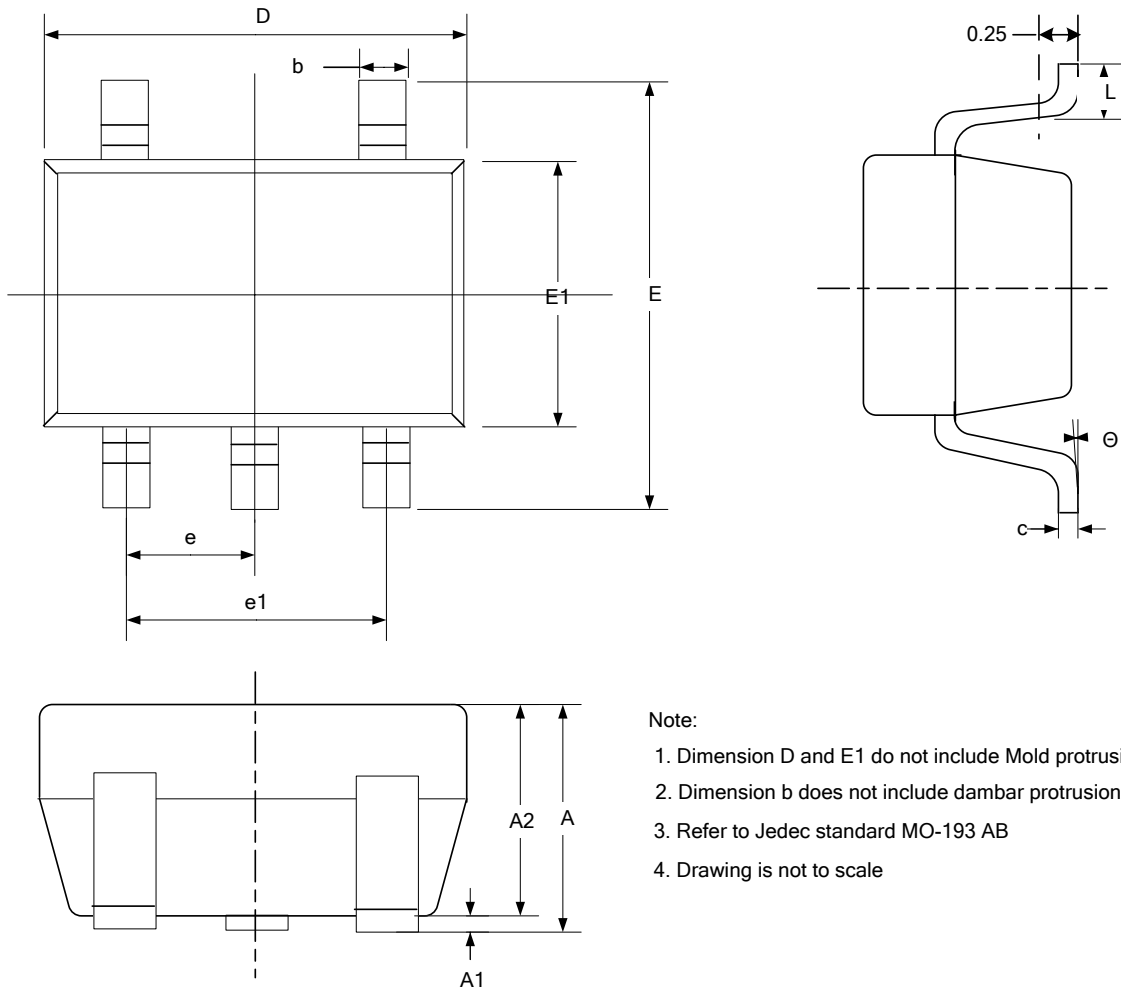

SYMBOLS	DIMENSIONS IN MILLIMETERS			DIMENSIONS IN INCHES		
	MIN	NOM	MAX	MIN	NOM	MAX
A	--	--	1.250	--	--	0.049
A1	0.000	--	0.150	0.000	--	0.006
A2	1.000	1.100	1.200	0.039	0.043	0.047
b	0.360	--	0.500	0.014	--	0.020
c	0.140	--	0.200	0.006	--	0.008
D	2.826	2.926	3.026	0.111	0.115	0.119
E	2.600	2.800	3.000	0.102	0.110	0.118
E1	1.526	1.626	1.726	0.060	0.064	0.068
e	0.95(BSC)			0.037(BSC)		
e1	1.90(BSC)			0.075(BSC)		
L	0.350	0.450	0.600	0.014	0.018	0.024
θ	0°	--	8°	0°	--	8°

# GT24C32D



## 10. Revision History

Revision	Date	Descriptions
V1.0	Jul. 2020	Initial spec

单击下面可查看定价，库存，交付和生命周期等信息

[>>Giantec\(聚辰半导体\)](#)