



MD25Q128

DATASHEET

Contents

1. FEATURES	4
2. GENERAL DESCRIPTION.....	5
3. MEMORY ORGANIZATION	8
4. DEVICE OPERATION	9
5. DATA PROTECTION.....	11
6. STATUS REGISTER.....	13
7. COMMANDS DESCRIPTION	15
7.1. WRITE ENABLE (WREN) (06H)	18
7.2. WRITE DISABLE (WRDI) (04H)	18
7.3. WRITE ENABLE FOR VOLATILE STATUS REGISTER (50H)	18
7.4. READ STATUS REGISTER (RDSR) (05H OR 35H OR 15H)	19
7.5. WRITE STATUS REGISTER (WRSR) (01H OR 31H OR 11H).....	19
7.6. READ DATA BYTES (READ) (03H).....	20
7.7. READ DATA BYTES AT HIGHER SPEED (FAST READ) (0BH)	21
7.8. DUAL OUTPUT FAST READ (3BH).....	21
7.9. QUAD OUTPUT FAST READ (6BH)	22
7.10. DUAL I/O FAST READ (BBH)	22
7.11. QUAD I/O FAST READ (EBH).....	23
7.12. SET BURST WITH WRAP (77H)	25
7.13. PAGE PROGRAM (PP) (02H)	25
7.14. QUAD PAGE PROGRAM (32H).....	26
7.15. SECTOR ERASE (SE) (20H).....	27
7.16. 32KB BLOCK ERASE (BE) (52H)	28
7.17. 64KB BLOCK ERASE (BE) (D8H)	28
7.18. CHIP ERASE (CE) (60/C7H)	29
7.19. DEEP POWER-DOWN (DP) (B9H).....	29
7.20. RELEASE FROM DEEP POWER-DOWN AND READ DEVICE ID (RDI) (ABH).....	30
7.21. READ MANUFACTURE ID/ DEVICE ID (REMS) (90H).....	31
7.22. READ IDENTIFICATION (RDID) (9FH).....	32
7.23. PROGRAM/ERASE SUSPEND (PES) (75H)	32
7.24. PROGRAM/ERASE RESUME (PER) (7AH)	33
7.25. ERASE SECURITY REGISTERS (44H)	33
7.26. PROGRAM SECURITY REGISTERS (42H).....	34
7.27. READ SECURITY REGISTERS (48H).....	35
7.28. ENABLE RESET (66H) AND RESET (99H).....	35
8. ELECTRICAL CHARACTERISTICS	37
8.1. POWER-ON TIMING.....	37
8.2. INITIAL DELIVERY STATE.....	37
8.3. ABSOLUTE MAXIMUM RATINGS	37



3.3V Uniform Sector Dual and Quad Serial Flash

MD25Q128

8.4.	CAPACITANCE MEASUREMENT CONDITIONS	38
8.5.	DC CHARACTERISTICS.....	39
8.6.	AC CHARACTERISTICS.....	41
9.	ORDERING INFORMATION	46
9.1.	VALID PART NUMBERS	47
10.	PACKAGE INFORMATION.....	48
10.1.	PACKAGE SOP8 208MIL	48
10.2.	PACKAGE VSOP8 208MIL.....	49
10.3.	PACKAGE SOP16 300MIL.....	50
10.4.	PACKAGE DIP8 300MIL	51
10.5.	PACKAGE WSON8 (6*5MM).....	52
10.6.	PACKAGE WSON8 (8*6MM).....	53
11.	REVISION HISTORY.....	54

1. FEATURES

- ◆ 128M-bit Serial Flash
 - 16384K-byte
 - 256 bytes per programmable page
- ◆ Standard, Dual, Quad SPI
 - Standard SPI: SCLK, CS#, SI, SO, WP#, HOLD#/ RESET#
 - Dual SPI: SCLK, CS#, IO0, IO1, WP#, HOLD#/ RESET#
 - Quad SPI: SCLK, CS#, IO0, IO1, IO2, IO3
- ◆ High Speed Clock Frequency
 - 104MHz for Standard and Dual SPI fast read with 30PF load
 - Dual I/O Data transfer up to 208Mbits/s
 - Quad I/O Data transfer up to 416Mbits/s
- ◆ Software/Hardware Write Protection
 - Write protect all/portion of memory via software
 - Enable/Disable protection with WP# Pin
 - Top/Bottom Block protection
- ◆ Allows XIP (execute in place) Operation
 - Continuous Read With 8/16/32/64-byte Wrap
- ◆ Minimum 100,000 Program/Erase Cycles
- ◆ Data Retention
 - 20-year data retention typical
- ◆ Fast Program/Erase Speed
 - Page Program time: 0.6ms typical
 - Sector Erase time: 50ms typical
 - Block Erase time: 0.2/0.3s typical
 - Chip Erase time: 60s typical
- ◆ Flexible Architecture
 - Uniform Sector of 4K-byte
 - Uniform Block of 32/64k-byte
- ◆ Low Power Consumption
 - 25mA maximum active current
 - 5uA maximum power down current
- ◆ Advanced Security Features⁽¹⁾
 - 3x1024-Byte Security Registers With OTP Locks
- ◆ Single Power Supply Voltage
 - Full voltage range: 2.7~3.6V
- ◆ Package Information
 - SOP8 (208mil)
 - VSOP8 (208mil)
 - SOP16 (300mil)
 - DIP8 (300mil)
 - WSON8 (8*6mm)
 - WSON8 (6*5mm)

Note: 1.Please contact GigaDevice for details.

2. GENERAL DESCRIPTION

The MD25Q128 (128M-bit) Serial flash supports the standard Serial Peripheral Interface (SPI), and supports the Dual/Quad SPI: Serial Clock, Chip Select, Serial Data I/O0 (SI), I/O1 (SO), I/O2 (WP#), and I/O3 (HOLD#/ RESET#). The Dual I/O data is transferred with speed of 208Mbits/s and the Quad I/O & Quad output data is transferred with speed of 416Mbits/s.

CONNECTION DIAGRAM

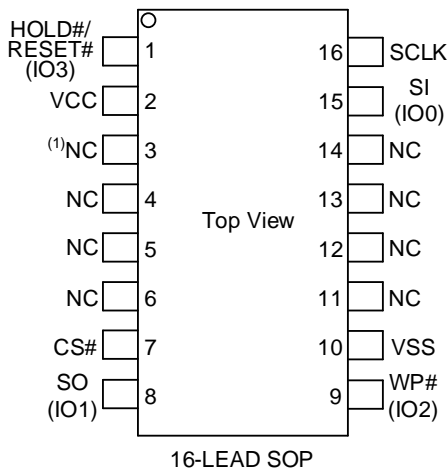
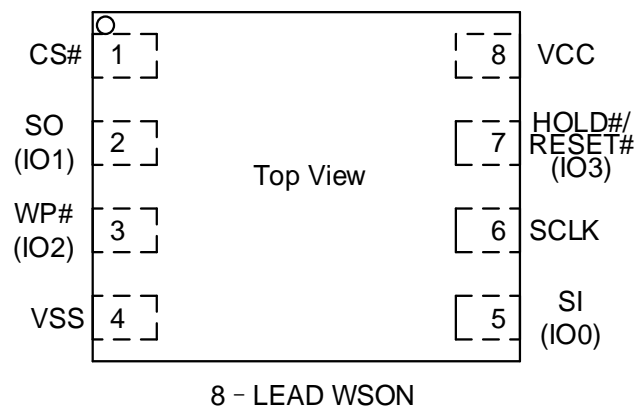
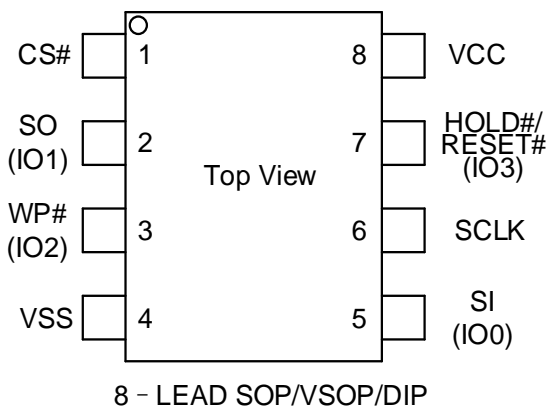

Note:

(1) Only for special order, Pin 3 of 16-LEAD SOP package is RESET# pin. Please contact GigaDevice for detail.



3.3V Uniform Sector Dual and Quad Serial Flash

MD25Q128

PIN DESCRIPTION

Pin Name	I/O	Description
CS#	I	Chip Select Input
SO (IO1)	I/O	Data Output (Data Input Output 1)
WP# (IO2)	I/O	Write Protect Input (Data Input Output 2)
VSS		Ground
SI (IO0)	I/O	Data Input (Data Input Output 0)
SCLK	I	Serial Clock Input
HOLD#/RESET# (IO3)	I/O	Hold or Reset Input (Data Input Output 3)
VCC		Power Supply

Note: CS# must be driven high if chip is not selected. Please don't leave CS# floating any time after power is on.

BLOCK DIAGRAM

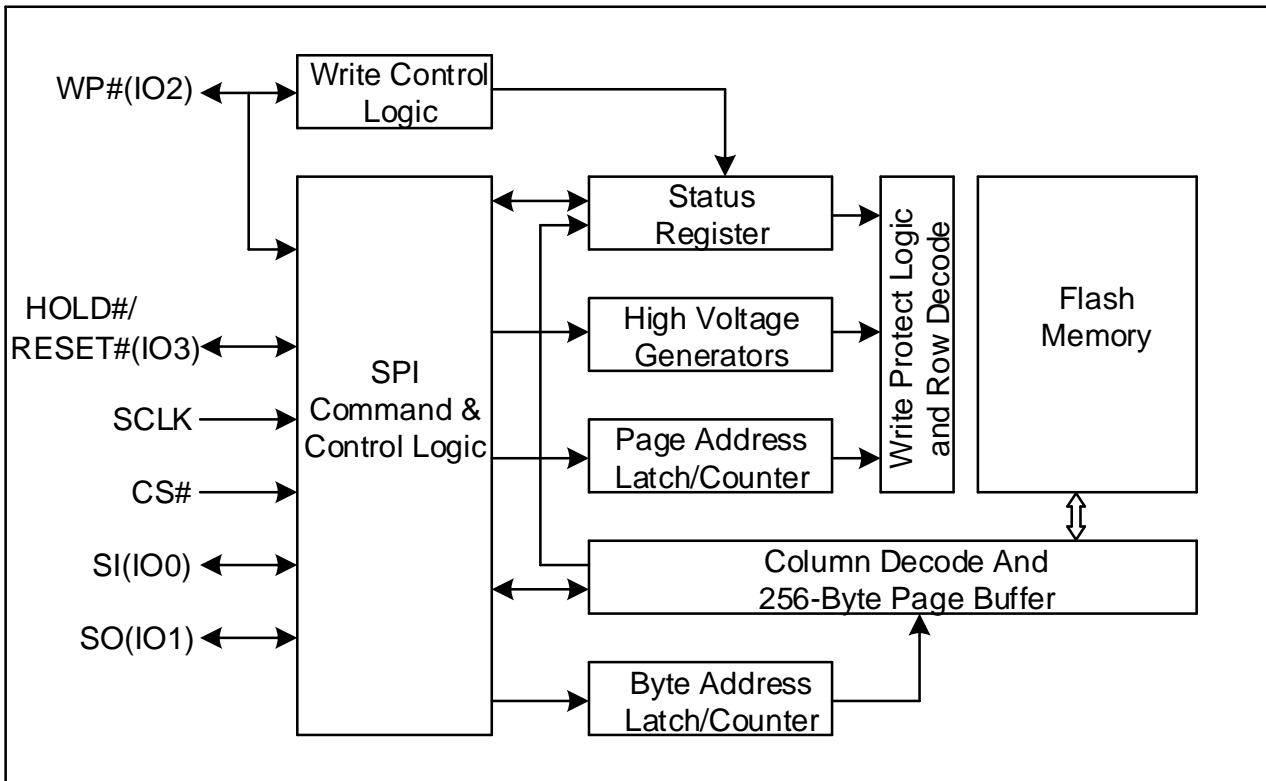



3. MEMORY ORGANIZATION

MD25Q128

Each device has	Each block has	Each sector has	Each page has	
16M	64/32K	4K	256	bytes
64K	256/128	16	-	pages
4096	16/8	-	-	sectors
256/512	-	-	-	blocks

UNIFORM BLOCK SECTOR ARCHITECTURE

MD25Q128 64K Bytes Block Sector Architecture

Block	Sector	Address range	
255	4095	FFF000H	FFFFFFFH

	4080	FF0000H	FF0FFFFH
254	4079	FEF000H	FEFFFFFFH

	4064	FE0000H	FE0FFFFH
.....

.....

2	47	02F000H	02FFFFFFH

	32	020000H	020FFFFH
1	31	01F000H	01FFFFFFH

	16	010000H	010FFFFH
0	15	00F000H	00FFFFFFH

	0	000000H	000FFFFH

4. DEVICE OPERATION

SPI Mode

Standard SPI

The MD25Q128 features a serial peripheral interface on 4 signals bus: Serial Clock (SCLK), Chip Select (CS#), Serial Data Input (SI) and Serial Data Output (SO). Both SPI bus mode 0 and 3 are supported. Input data is latched on the rising edge of SCLK and data shifts out on the falling edge of SCLK.

Dual SPI

The MD25Q128 supports Dual SPI operation when using the “Dual Output Fast Read” and “Dual I/O Fast Read” (3BH and BBH) commands. These commands allow data to be transferred to or from the device at twice the rate of the standard SPI. When using the Dual SPI command the SI and SO pins become bidirectional I/O pins: IO0 and IO1.

Quad SPI

The MD25Q128 supports Quad SPI operation when using the “Quad Output Fast Read”, “Quad I/O Fast Read”, “Quad I/O Word Fast Read”(6BH,EBH)commands. These commands allow data to be transferred to or from the device at four times the rate of the standard SPI. When using the Quad SPI command the SI and SO pins become bidirectional I/O pins: IO0 and IO1, and WP# and HOLD#/RESET# pins become IO2 and IO3. Quad SPI commands require the non-volatile Quad Enable bit(QE) in Status Register to be set.

Hold

The HOLD/RST bit is used to determine whether HOLD# or RESET# function should be implemented on the hardware pin for 8-pin packages. When HOLD/RST=0, the pin7 acts as HOLD#, the HOLD# function is only available when QE=0, If QE=1, The HOLD# functions is disabled, the pin acts as dedicated data I/O pin.

The HOLD# signal goes low to stop any serial communications with the device, but doesn't stop the operation of write status register, programming, or erasing in progress.

The operation of HOLD, need CS# keep low, and starts on falling edge of the HOLD# signal, with SCLK signal being low (if SCLK is not being low, HOLD operation will not start until SCLK being low). The HOLD condition ends on rising edge of HOLD# signal with SCLK being low (If SCLK is not being low, HOLD operation will not end until SCLK being low).

The SO is high impedance, both SI and SCLK don't care during the HOLD operation, if CS# drives high during HOLD operation, it will reset the internal logic of the device. To re-start communication with chip, the HOLD# must be at high and then CS# must be at low.

Figure1. Hold Condition

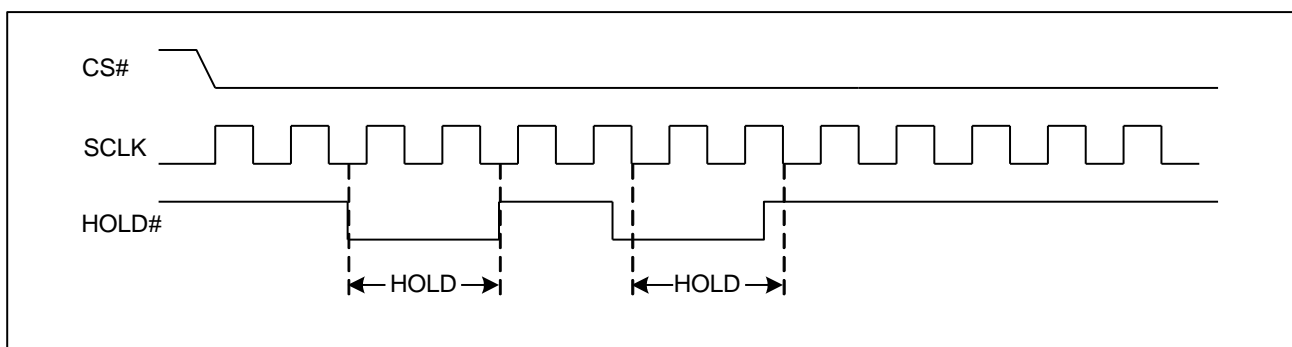

RESET

The RESET# pin allows the device to be reset by the control. For the WSON8 package, the pin7 can be configured as a RESET# pin depending on the status register setting, which need QE=0 and HOLD/RST=1. On the SOP16 package, a dedicated RESET# pin is provided and it is independent of QE bit setting.

The RESET# pin goes low for a period of t_{LRH} or longer will reset the flash. After reset cycle, the flash is at the following states:

- Standby mode
- All the volatile bits will return to the default status as power on.

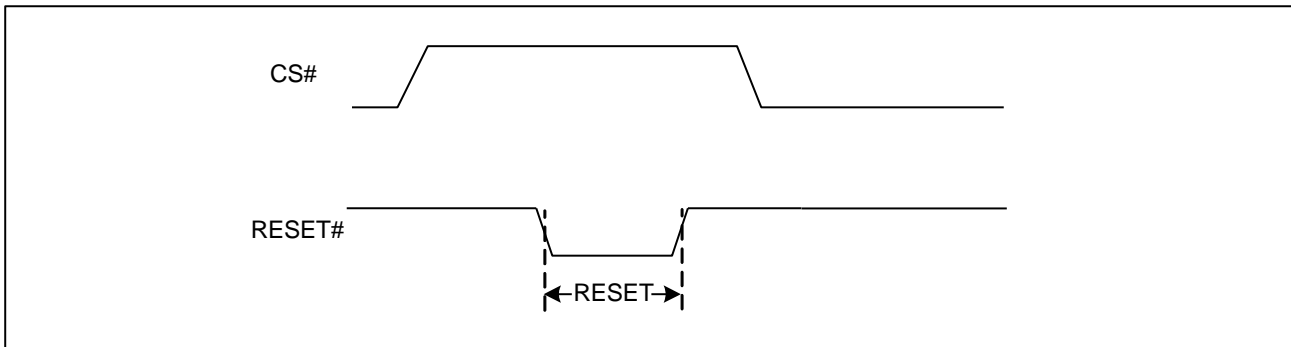
Figure2. RESET Condition

5. DATA PROTECTION

The MD25Q128 provide the following data protection methods:

- ◆ Write Enable (WREN) command: The WREN command is set the Write Enable Latch bit (WEL). The WEL bit will return to reset by the following situation:
 - Power-Up
 - Write Disable (WRDI)
 - Write Status Register (WRSR)
 - Page Program (PP)
 - Sector Erase (SE) / Block Erase (BE) / Chip Erase (CE)
- ◆ Software Protection Mode:
 - The Block Protect (BP4, BP3, BP2, BP1, and BP0) bits define the section of the memory array that can be read but not change.
- ◆ Hardware Protection Mode: WP# goes low to protect the writable bit of Status Register.
- ◆ Deep Power-Down Mode: In Deep Power-Down Mode, all commands are ignored except the Release from Deep Power-Down Mode command and reset command (66H+99H).

Table 5.1. MD25Q128 Protected area size (CMP=0)

Status Register Content					Memory Content			
BP4	BP3	BP2	BP1	BP0	Blocks	Addresses	Density	Portion
X	X	0	0	0	NONE	NONE	NONE	NONE
0	0	0	0	1	252 to 255	FC0000H-FFFFFFH	256KB	Upper 1/64
0	0	0	1	0	248 to 255	F80000H-FFFFFFH	512KB	Upper 1/32
0	0	0	1	1	240 to 255	F00000H-FFFFFFH	1MB	Upper 1/16
0	0	1	0	0	224 to 255	E00000H-FFFFFFH	2MB	Upper 1/8
0	0	1	0	1	192 to 255	C00000H-FFFFFFH	4MB	Upper 1/4
0	0	1	1	0	128 to 255	800000H-FFFFFFH	8MB	Upper 1/2
0	1	0	0	1	0 to 3	000000H-03FFFFH	256KB	Lower 1/64
0	1	0	1	0	0 to 7	000000H-07FFFFH	512KB	Lower 1/32
0	1	0	1	1	0 to 15	000000H-0FFFFFFH	1MB	Lower 1/16
0	1	1	0	0	0 to 31	000000H-1FFFFFFH	2MB	Lower 1/8
0	1	1	0	1	0 to 63	000000H-3FFFFFFH	4MB	Lower 1/4
0	1	1	1	0	0 to 127	000000H-7FFFFFFH	8MB	Lower 1/2
X	X	1	1	1	0 to 255	000000H-FFFFFFH	16MB	ALL
1	0	0	0	1	255	FFF000H-FFFFFFH	4KB	Top Block
1	0	0	1	0	255	FFE000H-FFFFFFH	8KB	Top Block
1	0	0	1	1	255	FFC000H-FFFFFFH	16KB	Top Block
1	0	1	0	X	255	FF8000H-FFFFFFH	32KB	Top Block
1	0	1	1	0	255	FF8000H-FFFFFFH	32KB	Top Block
1	1	0	0	1	0	000000H-000FFFH	4KB	Bottom Block
1	1	0	1	0	0	000000H-001FFFH	8KB	Bottom Block
1	1	0	1	1	0	000000H-003FFFH	16KB	Bottom Block
1	1	1	0	X	0	000000H-007FFFH	32KB	Bottom Block



3.3V Uniform Sector Dual and Quad Serial Flash

MD25Q128

1	1	1	1	0	0	000000H-007FFFFH	32KB	Bottom Block
---	---	---	---	---	---	------------------	------	--------------

Table 5.2. MD25Q128 Protected area size (CMP=1)

Status Register Content					Memory Content			
BP4	BP3	BP2	BP1	BP0	Blocks	Addresses	Density	Portion
X	X	0	0	0	0 to 255	000000H-FFFFFFH	ALL	ALL
0	0	0	0	1	0 to 251	000000H-FBFFFFH	16128KB	Lower 63/64
0	0	0	1	0	0 to 247	000000H-F7FFFFH	15872KB	Lower 31/32
0	0	0	1	1	0 to 239	000000H-EFFFFFFH	15MB	Lower 15/16
0	0	1	0	0	0 to 223	000000H-DFFFFFFH	14MB	Lower 7/8
0	0	1	0	1	0 to 191	000000H-BFFFFFFH	12MB	Lower 3/4
0	0	1	1	0	0 to 127	000000H-7FFFFFFH	8MB	Lower 1/2
0	1	0	0	1	4 to 255	040000H-FFFFFFH	16128KB	Upper 63/64
0	1	0	1	0	8 to 255	080000H-FFFFFFH	15872KB	Upper 31/32
0	1	0	1	1	16 to 255	100000H-FFFFFFH	15MB	Upper 15/16
0	1	1	0	0	32 to 255	200000H-FFFFFFH	14MB	Upper 7/8
0	1	1	0	1	64 to 255	400000H-FFFFFFH	12MB	Upper 3/4
0	1	1	1	0	128 to 255	800000H-FFFFFFH	8MB	Upper 1/2
X	X	1	1	1	NONE	NONE	NONE	NONE
1	0	0	0	1	0 to 255	000000H-FFEFFFFH	16380KB	L-4095/4096
1	0	0	1	0	0 to 255	000000H-FFDFFFFH	16376KB	L-2047/2048
1	0	0	1	1	0 to 255	000000H-FFBFFFFH	16368KB	L-1023/1024
1	0	1	0	X	0 to 255	000000H-FF7FFFFH	16352KB	L-511/512
1	0	1	1	0	0 to 255	000000H-FF7FFFFH	16352KB	L-511/512
1	1	0	0	1	0 to 255	001000H-FFFFFFH	16380KB	U-4095/4096
1	1	0	1	0	0 to 255	002000H-FFFFFFH	16376KB	U-2047/2048
1	1	0	1	1	0 to 255	004000H-FFFFFFH	16368KB	U-1023/1024
1	1	1	0	X	0 to 255	008000H-FFFFFFH	16352KB	U-511/512
1	1	1	1	0	0 to 255	008000H-FFFFFFH	16352KB	U-511/512

6. STATUS REGISTER

S23	S22	S21	S20	S19	S18	S17	S16
HOLD/RST	DRV1	DRV0	Reserved	Reserved	LPE	Reserved	Reserved

S15	S14	S13	S12	S11	S10	S9	S8
SUS1	CMP	LB3	LB2	LB1	SUS2	QE	SRP1

S7	S6	S5	S4	S3	S2	S1	S0
SRP0	BP4	BP3	BP2	BP1	BP0	WEL	WIP

The status and control bits of the Status Register are as follows:

WIP bit.

The Write in Progress (WIP) bit indicates whether the memory is busy in program/erase/write status register progress. When WIP bit sets to 1, means the device is busy in program/erase/write status register progress, when WIP bit sets 0, means the device is not in program/erase/write status register progress.

WEL bit.

The Write Enable Latch (WEL) bit indicates the status of the internal Write Enable Latch. When set to 1 the internal Write Enable Latch is set, when set to 0 the internal Write Enable Latch is reset and no Write Status Register, Program or Erase command is accepted.

BP4, BP3, BP2, BP1, BP0 bits.

The Block Protect (BP4, BP3, BP2, BP1 and BP0) bits are non-volatile. They define the size of the area to be software protected against Program and Erase commands. These bits are written with the Write Status Register (WRSR) command. When the Block Protect (BP4, BP3, BP2, BP1, BP0) bits are set to 1, the relevant memory area (as defined in Table1).becomes protected against Page Program (PP), Sector Erase (SE) and Block Erase (BE) commands. The Block Protect (BP4, BP3, BP2, BP1, and BP0) bits can be written provided that the Hardware Protected mode has not been set. The Chip Erase (CE) command is executed, only if the Block Protect (BP2, BP1, and BP0) bits are 0 and CMP=0 or the Block Protect (BP2, BP1, and BP0) bits are 1 and CMP=1.

SRP1, SRP0 bits.

The Status Register Protect (SRP1 and SRP0) bits are non-volatile Read/Write bits in the status register. The SRP bits control the method of write protection: software protection, hardware protection, power supply lock-down or one time programmable protection.

SRP1	SRP0	#WP	Status Register	Description
0	0	X	Software Protected	The Status Register can be written to after a Write Enable command, WEL=1.(Default)
0	1	0	Hardware Protected	WP#=0, the Status Register locked and cannot be written to.
0	1	1	Hardware Unprotected	WP#=1, the Status Register is unlocked and can be written to after a Write Enable command, WEL=1.
1	0	X	Power Supply Lock-Down ⁽¹⁾⁽²⁾	Status Register is protected and cannot be written to again until the next Power-Down, Power-Up cycle.
1	1	X	One Time Program ⁽²⁾	Status Register is permanently protected and cannot be written to.

NOTE:

1. When SRP1, SRP0= (1, 0), a Power-Down, Power-Up cycle will change SRP1, SRP0 to (0, 0) state.

2. This feature is available on special order. (MD25Q128xxSx) Please contact GigaDevice for details.

QE bit.

The Quad Enable (QE) bit is a non-volatile Read/Write bit in the Status Register that allows Quad operation. When the QE bit is set to 0 (Default) the WP# pin and HOLD# / RESET# pin are enable. When the QE pin is set to 1, the Quad IO2 and IO3 pins are enabled. (The QE bit should never be set to 1 during standard SPI or Dual SPI operation if the WP# or HOLD# / RESET# pins are tied directly to the power supply or ground)

LB3, LB2, LB1 bits.

The LB3, LB2, LB1 bits are non-volatile One Time Program (OTP) bits in Status Register (S13-S11) that provide the write protect control and status to the Security Registers. The default state of LB3-LB1 are 0, the security registers are unlocked. The LB3-LB1 bits can be set to 1 individually using the Write Register instruction. The LB3-LB1 bits are One Time Programmable, once they are set to 1, the Security Registers will become read-only permanently.

CMP bit

The CMP bit is a non-volatile Read/Write bit in the Status Register (S14). It is used in conjunction with the BP4-BP0 bits to provide more flexibility for the array protection. Please see the Status registers Memory Protection table for details. The default setting is CMP=0.

SUS1, SUS2 bits

The SUS1 and SUS2 bits are read only bits in the status register (S15 and S10) that are set to 1 after executing an Program/Erase Suspend (75H) command (The Erase Suspend will set the SUS1 to 1, and the Program Suspend will set the SUS2 to 1). The SUS1 and SUS2 bits are cleared to 0 by Program/Erase Resume (7AH) command, software reset (66H+99H) command as well as a power-down, power-up cycle.

DRV1/DRV0

The DRV1&DRV0 bits are used to determine the output driver strength for the Read operations.

DRV1,DRV0	Driver Strength
00	100%
01	75%
10	50% (default)
11	25%

HOLD/RST bit

The HOLD/RST bit is used to determine whether HOLD# or RESET# function should be implemented on the hardware pin for 8-pin packages. When HOLD/RST=0, the pin acts as HOLD#, When the HOLD/RST=1, the pin acts as RESET#. However, the HOLD# or RESET# function are only available when QE=0, If QE=1, The HOLD# and RESET# functions are disabled, the pin acts as dedicated data I/O pin.

LPE bit

The Low Power Enable (LPE) bit is a non-volatile writable bit, indicating the status of Low Power Mode (LPM). When LPE bit sets to 1, it means the device is in Low Power Mode, when LPE bit sets 0 (default), it means the device is not in Low Power Mode.

7. COMMANDS DESCRIPTION

All commands, addresses and data are shifted in and out of the device, beginning with the most significant bit on the first rising edge of SCLK after CS# is driven low. Then, the one-byte command code must be shifted in to the device, with most significant bit first on SI, and each bit being latched on the rising edges of SCLK.

See Table 7.1., every command sequence starts with a one-byte command code. Depending on the command, this might be followed by address bytes, or by data bytes, or by both or none. CS# must be driven high after the last bit of the command sequence has been completed. For the command of Read, Fast Read, Read Status Register or Release from Deep Power-Down, and Read Device ID, the shifted-in command sequence is followed by a data-out sequence. CS# can be driven high after any bit of the data-out sequence is being shifted out.

For the command of Page Program, Sector Erase, Block Erase, Chip Erase, Write Status Register, Write Enable, Write Disable or Deep Power-Down command, CS# must be driven high exactly at a byte boundary, otherwise the command is rejected, and is not executed. That is CS# must be driven high when the number of clock pulses after CS# being driven low is an exact multiple of eight. For Page Program, if at any time the input byte is not a full byte, nothing will happen and WEL will not be reset.

Table 7.1. Commands (Standard/Dual/Quad SPI)

Command Name	Byte 1	Byte 2	Byte 3	Byte 4	Byte 5	Byte 6	n-Bytes
Write Enable	06H						
Write Disable	04H						
Volatile SR Write Enable	50H						
Read Status Register-1	05H	(S7-S0)					(continuous)
Read Status Register-2	35H	(S15-S8)					(continuous)
Read Status Register-3	15H	(S23-S16)					
Write Status Register-1	01H	S7-S0					
Write Status Register-2	31H	S15-S8					
Write Status Register-3	11H	S23-S16					
Read Data	03H	A23-A16	A15-A8	A7-A0	(D7-D0)	(Next byte)	(continuous)
Fast Read	0BH	A23-A16	A15-A8	A7-A0	dummy	(D7-D0)	(continuous)
Dual Output Fast Read	3BH	A23-A16	A15-A8	A7-A0	dummy	(D7-D0) ⁽¹⁾	(continuous)
Dual I/O Fast Read	BBH	A23-A8 ⁽²⁾	A7-A0 M7-M0 ⁽²⁾	(D7-D0) ⁽¹⁾			(continuous)
Quad Output Fast Read	6BH	A23-A16	A15-A8	A7-A0	dummy	(D7-D0) ⁽³⁾	(continuous)
Quad I/O Fast Read	EBH	A23-A0 M7-M0 ⁽⁴⁾	dummy ⁽⁵⁾	(D7-D0) ⁽³⁾			(continuous)
Page Program	02H	A23-A16	A15-A8	A7-A0	D7-D0	Next byte	
Quad Page Program	32H	A23-A16	A15-A8	A7-A0	D7-D0		
Sector Erase	20H	A23-A16	A15-A8	A7-A0			
Block Erase(32K)	52H	A23-A16	A15-A8	A7-A0			
Block Erase(64K)	D8H	A23-A16	A15-A8	A7-A0			
Chip Erase	C7/60 H						
Enable Reset	66H						
Reset	99H						
Set Burst with Wrap	77H	dummy ⁽⁸⁾ W7-W0					
Program/Erase Suspend	75H						
Program/Erase Resume	7AH						



3.3V Uniform Sector Dual and Quad Serial Flash

MD25Q128

Release From Deep Power-Down, And Read Device ID	ABH	dummy	dummy	dummy	(DID7-DID0)		(continuous)
Release From Deep Power-Down	ABH						
Deep Power-Down	B9H						
Manufacturer/ Device ID	90H	00H	00H	00H	(MID7-MID0)	(DID7-DID0)	(continuous)
Read Identification	9FH	(MID7-MID0)	(JDID15-JDID8)	(JDID7-JDID0)			(continuous)
Erase Security Registers ⁽⁷⁾	44H	A23-A16	A15-A8	A7-A0			
Program Security Registers ⁽⁷⁾	42H	A23-A16	A15-A8	A7-A0	D7-D0	D7-D0	
Read Security Registers ⁽⁷⁾	48H	A23-A16	A15-A8	A7-A0	dummy	(D7-D0)	

NOTE:

1. Dual Output data

IO0=(D6,D4,D2,D0)

IO1=(D7,D5,D3,D1)

2. Dual Input Address

IO0=A22,A20,A18,A16,A14,A12,A10,A8 A6,A4,A2,A0,M6,M4,M2,M0

IO1=A23,A21,A19,A17,A15,A13,A11,A9 A7,A5,A3,A1,M7,M5,M3,M1

3. Quad Output Data

IO0=(D4,D0,.....)

IO1=(D5,D1,.....)

IO2=(D6,D2,.....)

IO3=(D7,D3,.....)

4. Quad Input Address

IO0=A20,A16,A12,A8, A4,A0,M4,M0

IO1=A21,A17,A13,A9, A5,A1,M5,M1

IO2=A22,A18,A14,A10,A6,A2,M6,M2

IO3=A23,A19,A15,A11,A7,A3,M7,M3

5. Fast Read Quad I/O Data

IO0=(x,x,x,x, D4, D0,...)

IO1=(x,x,x,x, D5, D1,...)

IO2=(x,x,x,x, D6, D2,...)

IO3=(x,x,x,x, D7, D3,...)

6. Fast Word Read Quad I/O Data

IO0=(x,x, D4, D0,...)

IO1=(x,x, D5, D1,...)

IO2=(x,x, D6, D2,...)

IO3=(x,x, D7, D3,...)

7. Security Registers Address:

Security Register1: A23-A16=00H, A15-A10=000100b, A9-A0=Byte Address;

Security Register2: A23-A16=00H, A15-A10=001000b, A9-A0=Byte Address;

Security Register3: A23-A16=00H, A15-A10=001100b, A9-A0=Byte Address.

8. Dummy bits and Wrap Bits

IO0=(x,x, x,x, x,x, W4,x)

IO1=(x,x, x,x, x,x, W5, x)

IO2=(x,x, x,x, x,x, W6, x)

IO3=(x,x, x,x, x,x, x, x)

9.Address, Continuous Read Mode bits, Dummy bits, Manufacture ID and Device ID

IO0=(A20, A16, A12, A8, A4, A0, M4, M0, x,x, x,x, MID4, MID0, DID4, DID0, ...)

IO1=(A21, A17, A13, A9, A5, A1, M5, M1, x,x, x,x, MID5, MID1, DID5, DID1, ...)

IO2=(A22, A18, A14, A10, A6, A2, M6, M2,x,x, x,x, MID6, MID2, DID6, DID2, ...)

IO3=(A23, A19, A15, A11, A7, A3, M7, M3, x,x, x,x, MID7, MID3, DID7, DID3, ...)

Table 7.2. Table of ID Definitions for MD25Q128

Operation Code	MID7-MID0	ID15-ID8	ID7-ID0
9FH	C8	40	18
90H	C8		17
ABH			17

7.1. Write Enable (WREN) (06H)

The Write Enable (WREN) command is for setting the Write Enable Latch (WEL) bit. The Write Enable Latch (WEL) bit must be set prior to every Page Program (PP), Sector Erase (SE), Block Erase (BE), Chip Erase (CE), Write Status Register (WRSR) and Erase/Program Security Registers command. The Write Enable (WREN) command sequence: CS# goes low → sending the Write Enable command → CS# goes high.

Figure3. Write Enable Sequence Diagram

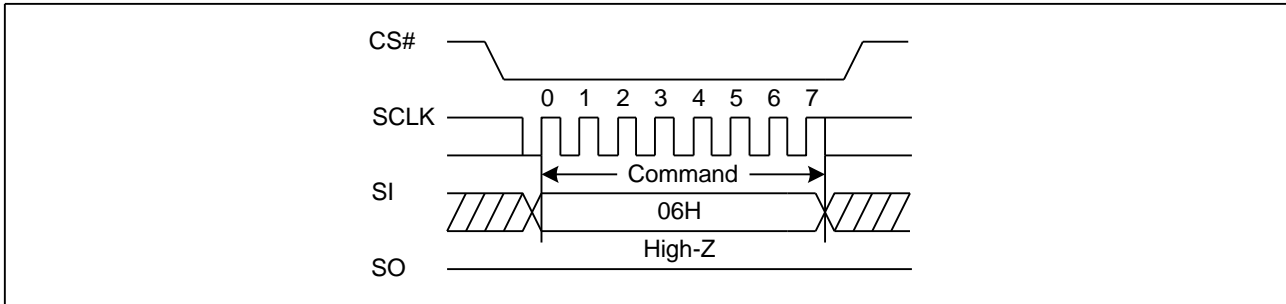

7.2. Write Disable (WRDI) (04H)

The Write Disable command is for resetting the Write Enable Latch (WEL) bit. The Write Disable command sequence: CS# goes low → Sending the Write Disable command → CS# goes high. The WEL bit is reset by following condition: Power-up and upon completion of the Write Status Register, Page Program, Sector Erase, Block Erase, Chip Erase, Erase/Program Security Registers and Reset commands.

Figure4. Write Disable Sequence Diagram

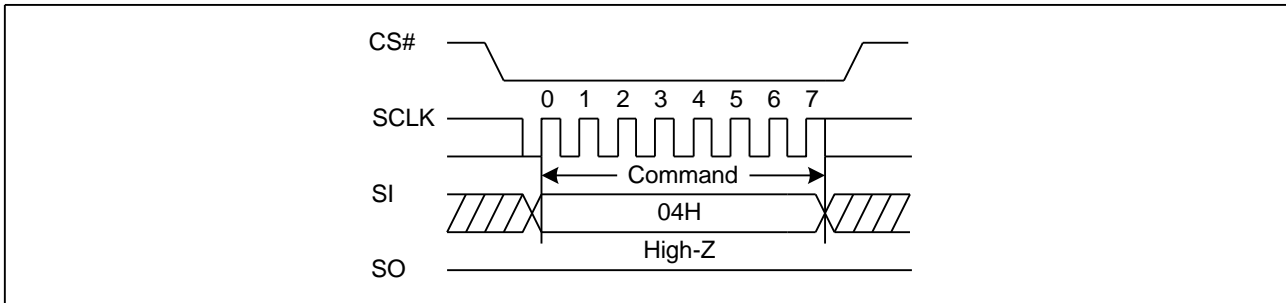

7.3. Write Enable for Volatile Status Register (50H)

The non-volatile Status Register bits can also be written to as volatile bits. This gives more flexibility to change the system configuration and memory protection schemes quickly without waiting for the typical non-volatile bit write cycles or affecting the endurance of the Status Register non-volatile bits. The Write Enable for Volatile Status Register command must be issued prior to a Write Status Register command, and any other commands cannot be inserted between them. Otherwise, Write Enable for Volatile Status Register will be cleared. The Write Enable for Volatile Status Register command will not set the Write Enable Latch bit, it is only valid for the Write Status Register command to change the volatile Status Register bit values.

Figure5. Write Enable for Volatile Status Register Sequence Diagram

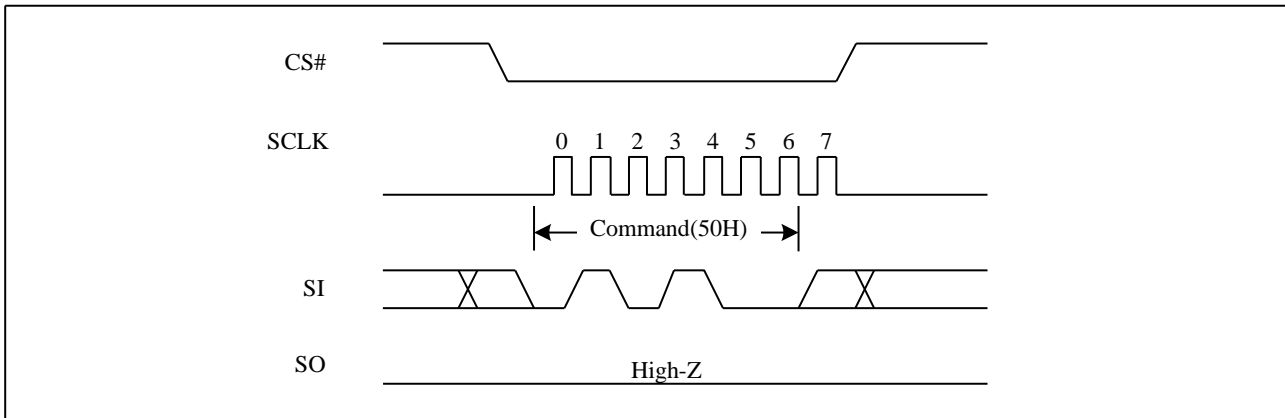

7.4. Read Status Register (RDSR) (05H or 35H or 15H)

The Read Status Register (RDSR) command is for reading the Status Register. The Status Register may be read at any time, even while a Program, Erase or Write Status Register cycle is in progress. When one of these cycles is in progress, it is recommended to check the Write in Progress (WIP) bit before sending a new command to the device. It is also possible to read the Status Register continuously. For command code “05H”/ “35H” / “15H”, the SO will output Status Register bits S7~S0/ S15~S8 / S16~S23.

Figure6. Read Status Register Sequence Diagram

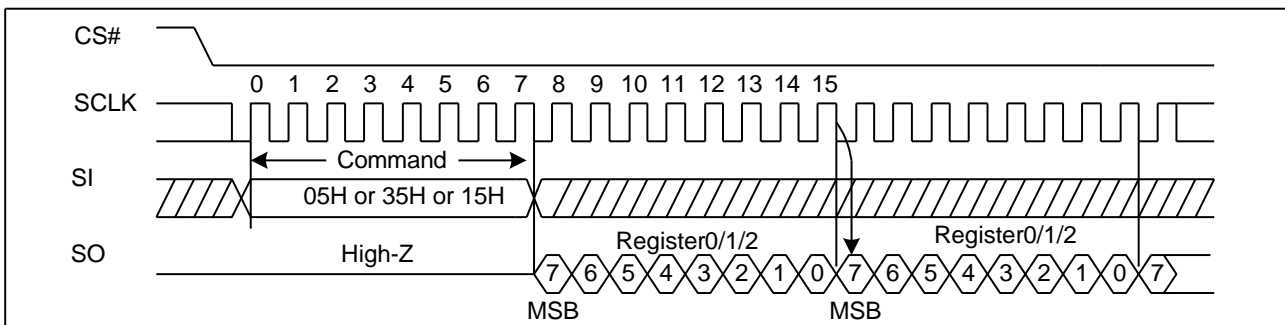

7.5. Write Status Register (WRSR) (01H or 31H or 11H)

The Write Status Register (WRSR) command allows new values to be written to the Status Register. Before it can be accepted, a Write Enable (WREN) command must previously have been executed. After the Write Enable (WREN) command has been decoded and executed, the device sets the Write Enable Latch (WEL).

The Write Status Register (WRSR) command has no effect on S20, S19, S17, S16, S15, S10, S1 and S0 of the Status Register. CS# must be driven high after the eighth of the data byte has been latched in. If not, the Write Status Register (WRSR) command is not executed. As soon as CS# is driven high, the self-timed Write Status Register cycle (whose duration is t_w) is initiated. While the Write Status Register cycle is in progress, the Status Register may still be read to check the value of the Write In Progress (WIP) bit. The Write In Progress (WIP) bit is 1 during the self-timed Write Status Register cycle, and is 0 when it is completed. When the cycle is completed, the Write Enable Latch (WEL) is reset.

The Write Status Register (WRSR) command allows the user to change the values of the Block Protect (BP4, BP3, BP2, BP1, and BP0) bits, to define the size of the area that is to be treated as read-only. The Write Status Register (WRSR) command also allows the user to set or reset the Status Register Protect (SRP1 and SRP0) bits in accordance with the Write Protect (WP#) signal. The Status Register Protect (SRP1 and SRP0) bits and Write Protect (WP#) signal allow the device to be put in the Hardware Protected Mode. The Write Status Register (WRSR) command is not executed once the

Hardware Protected Mode is entered.

Figure7. Write Status Register Sequence Diagram

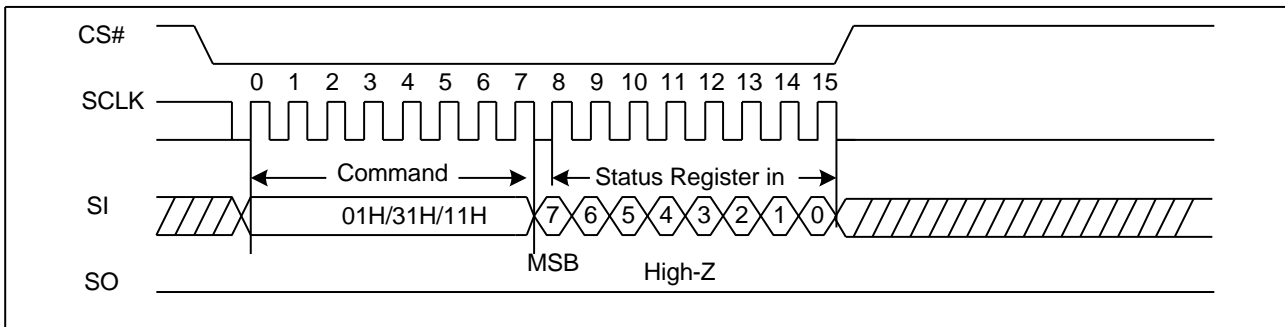

7.6. Read Data Bytes (READ) (03H)

The Read Data Bytes (READ) command is followed by a 3-byte address (A23-A0), and each bit is latched-in on the rising edge of SCLK. Then the memory content, at that address, is shifted out on SO, each bit being shifted out, at a Max frequency f_R , during the falling edge of SCLK. Then the memory content at that address is shifted out on SO. The first byte addressed can be at any location. The address is automatically incremented to the next higher address after each byte of data is shifted out. The whole memory can, therefore, be read with a single Read Data Bytes (READ) command. Any Read Data Bytes (READ) command, while an Erase, Program or Write cycle is in progress, is rejected without having any effects on the cycle that is in progress.

Figure8. Read Data Bytes Sequence Diagram

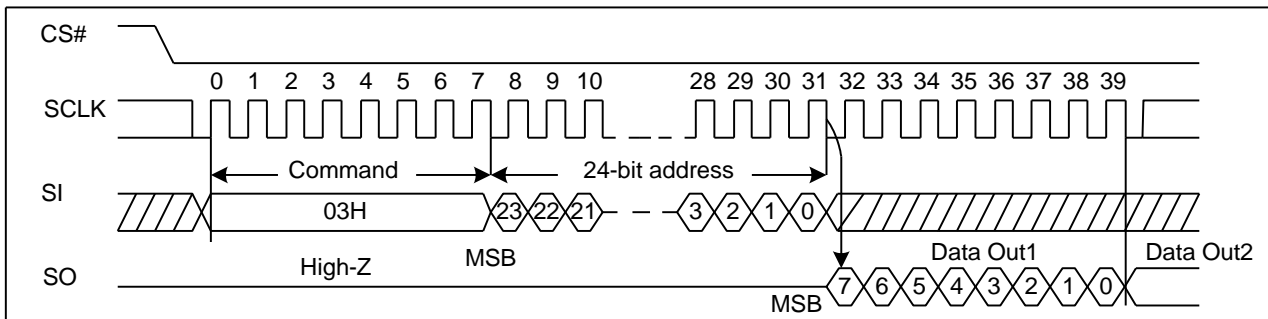

7.7. Read Data Bytes at Higher Speed (Fast Read) (0BH)

The Read Data Bytes at Higher Speed (Fast Read) command is for quickly reading data out. It is followed by a 3-byte address (A23-A0) and a dummy byte, each bit being latched-in during the rising edge of SCLK. Then the memory content, at that address, is shifted out on SO, each bit being shifted out, at a Max frequency f_c , during the falling edge of SCLK. The first byte addressed can be at any location. The address is automatically incremented to the next higher address after each byte of data is shifted out.

Figure9. Read Data Bytes at Higher Speed Sequence Diagram

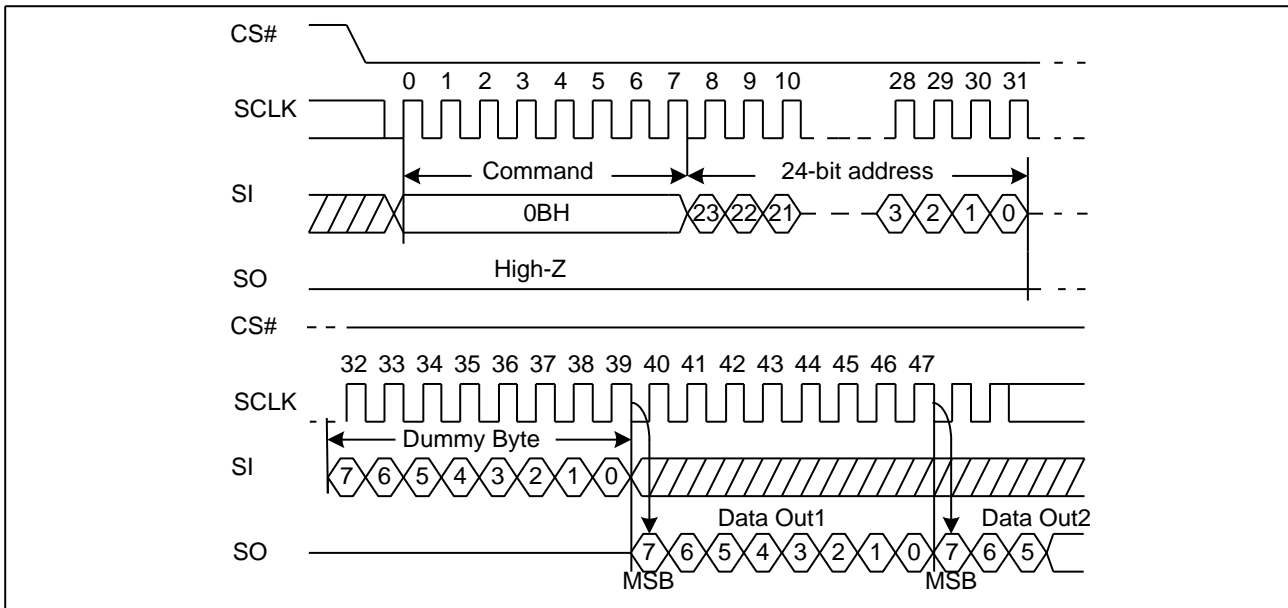

7.8. Dual Output Fast Read (3BH)

The Dual Output Fast Read command is followed by 3-byte address (A23-A0) and a dummy byte, each bit being latched in during the rising edge of SCLK, then the memory contents are shifted out 2-bit per clock cycle from SI and SO. The command sequence is shown in followed Figure 10. The first byte addressed can be at any location. The address is automatically incremented to the next higher address after each byte of data is shifted out.

Figure10. Dual Output Fast Read Sequence Diagram

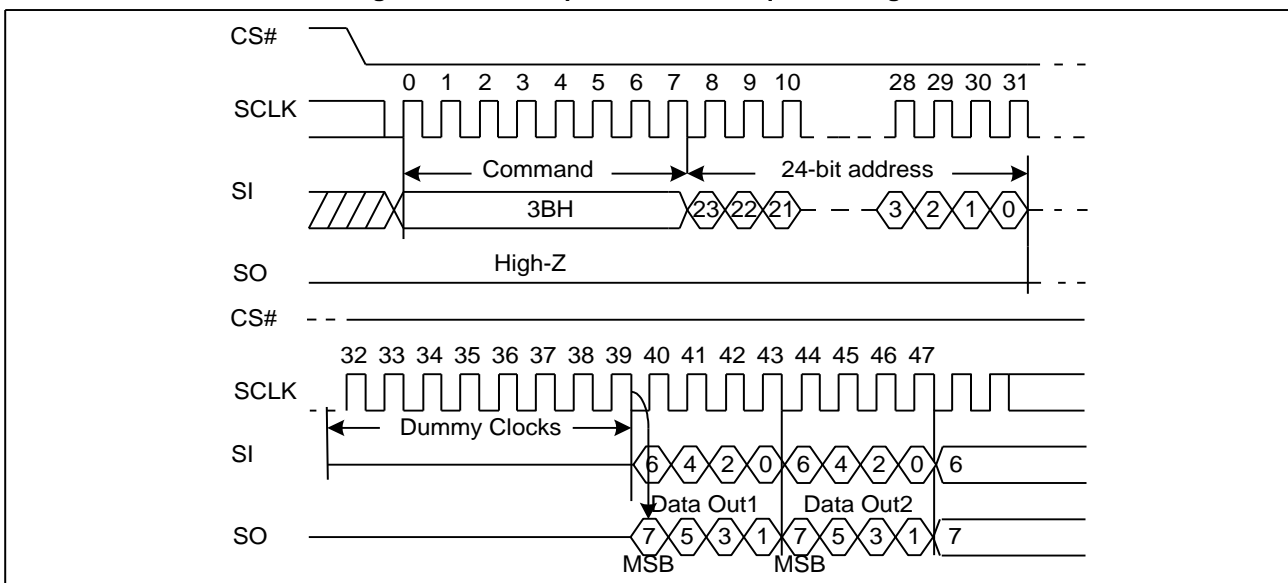

7.9. Quad Output Fast Read (6BH)

The Quad Output Fast Read command is followed by 3-byte address (A23-A0) and a dummy byte, each bit being latched in during the rising edge of SCLK, then the memory contents are shifted out 4-bit per clock cycle from IO3, IO2, IO1 and IO0. The command sequence is shown in followed Figure11. The first byte addressed can be at any location. The address is automatically incremented to the next higher address after each byte of data is shifted out.

Figure11. Quad Output Fast Read Sequence Diagram

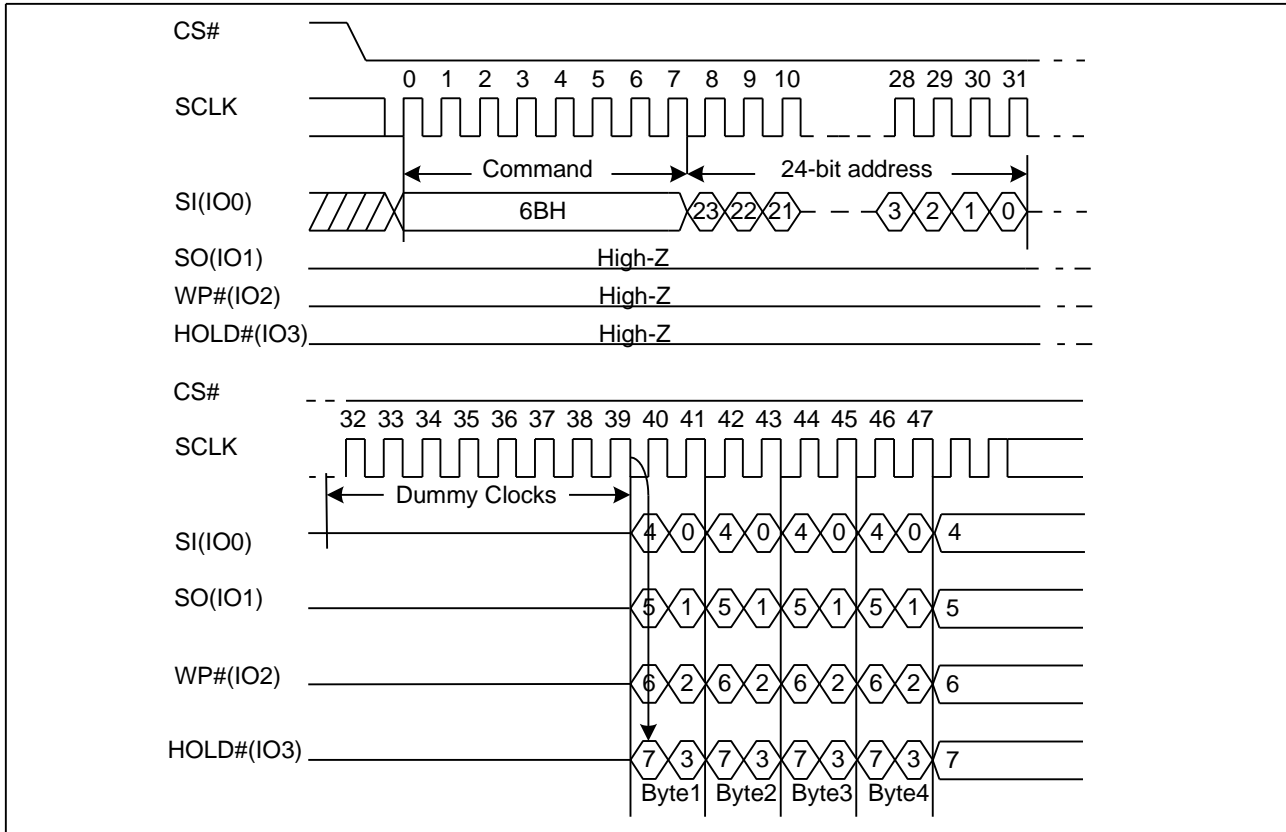

7.10. Dual I/O Fast Read (BBH)

The Dual I/O Fast Read command is similar to the Dual Output Fast Read command but with the capability to input the 3-byte address (A23-0) and a “Continuous Read Mode” byte 2-bit per clock by SI and SO, each bit being latched in during the rising edge of SCLK, then the memory contents are shifted out 2-bit per clock cycle from SI and SO. The command sequence is shown in followed Figure12. The first byte addressed can be at any location. The address is automatically incremented to the next higher address after each byte of data is shifted out.

Dual I/O Fast Read with “Continuous Read Mode”

The Dual I/O Fast Read command can further reduce command overhead through setting the “Continuous Read Mode” bits (M7-4) after the input 3-byte address (A23-A0). If the “Continuous Read Mode” bits (M5-4)= (1, 0), then the next Dual I/O Fast Read command (after CS# is raised and then lowered) does not require the BBH command code. The command sequence is shown in followed Figure12a. If the “Continuous Read Mode” bits (M5-4) do not equal (1, 0), the next command requires the first BBH command code, thus returning to normal operation. A “Continuous Read Mode” Reset command can be used to reset (M5-4) before issuing normal command.

Figure12. Dual I/O Fast Read Sequence Diagram (M5-4≠(1, 0))

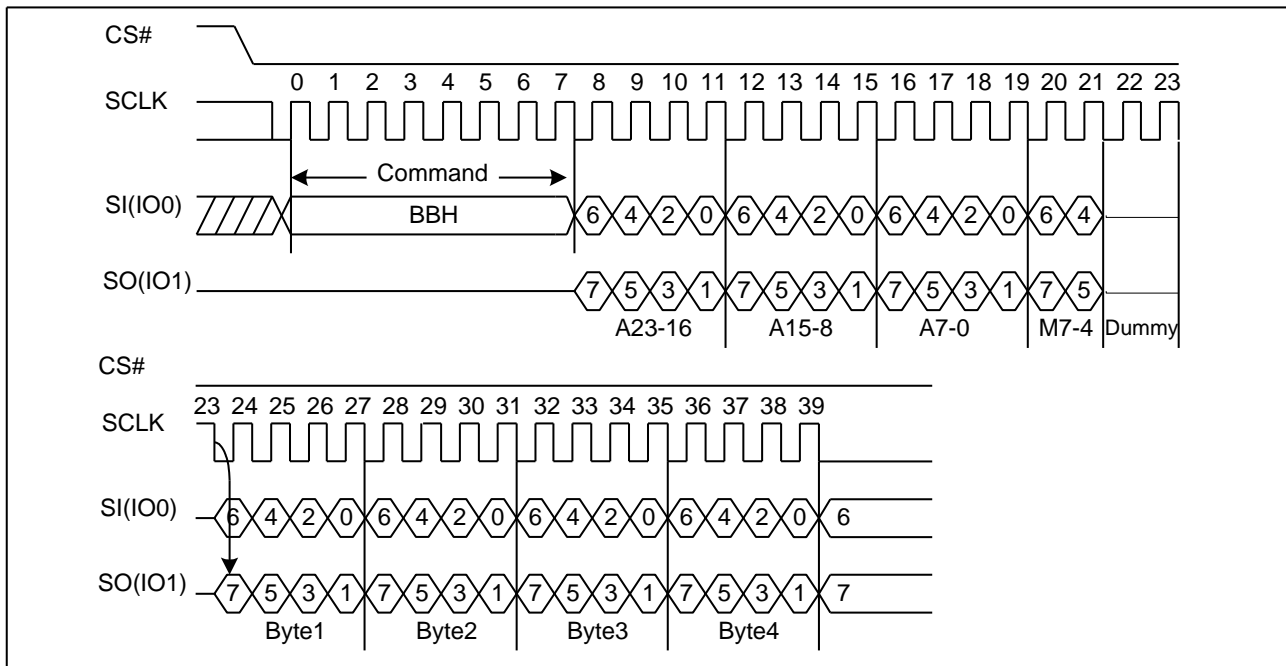
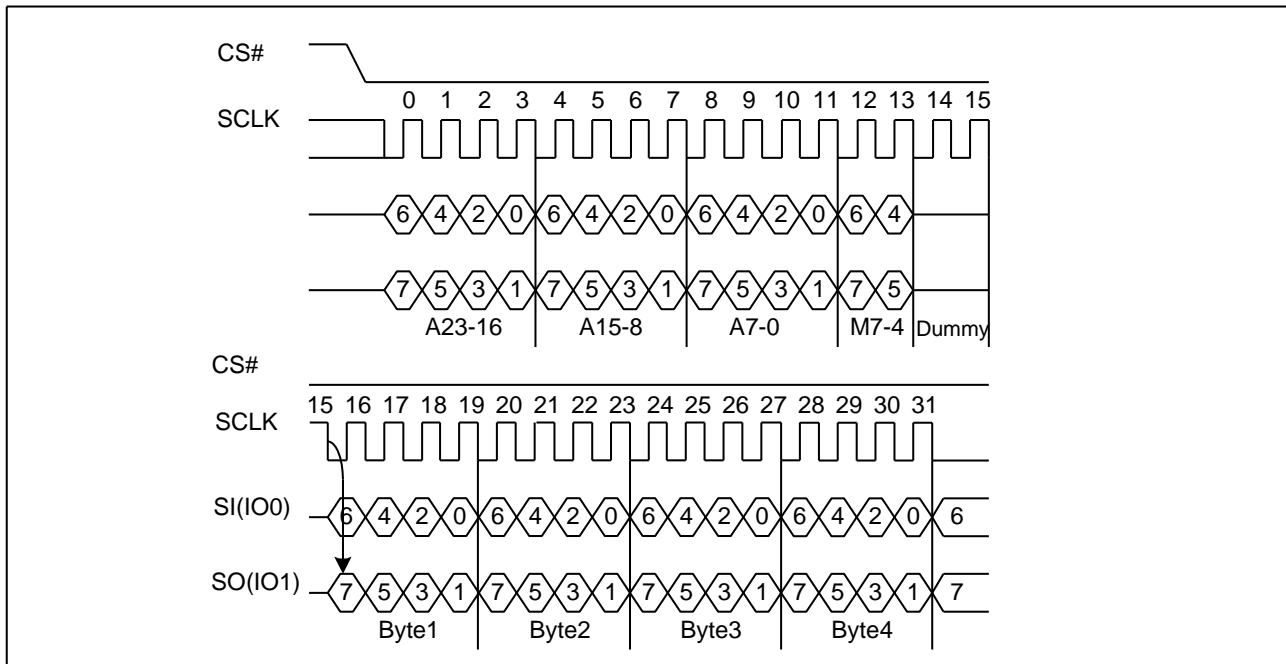

Figure12a. Dual I/O Fast Read Sequence Diagram (M5-4= (1, 0))



7.11. Quad I/O Fast Read (EBH)

The Quad I/O Fast Read command is similar to the Dual I/O Fast Read command but with the capability to input the 3-byte address (A23-0) and a “Continuous Read Mode” byte and 4-dummy clock4-bit per clock by IO0, IO1, IO2, IO3, each bit being latched in during the rising edge of SCLK, then the memory contents are shifted out 4-bit per clock cycle from IO0, IO1, IO2, IO3. The command sequence is shown in followed Figure13. The first byte addressed can be at any location. The address is automatically incremented to the next higher address after each byte of data is shifted out. The Quad Enable bit (QE) of Status Register (S9) must be set to enable for the Quad I/O Fast read command.

Quad I/O Fast Read with “Continuous Read Mode”

The Quad I/O Fast Read command can further reduce command overhead through setting the “Continuous Read Mode” bits (M7-0) after the input 3-byte address (A23-A0). If the “Continuous Read Mode” bits (M5-4) = (1, 0), then the next Quad I/O Fast Read command (after CS# is raised and then lowered) does not require the EBH command code. The command sequence is shown in followed Figure13a. If the “Continuous Read Mode” bits (M5-4) do not equal to (1, 0), the next command requires the first EBH command code, thus returning to normal operation. A “Continuous Read Mode” Reset command can be used to reset (M5-4) before issuing normal command.

Figure13. Quad I/O Fast Read Sequence Diagram (M5-4≠(1, 0))

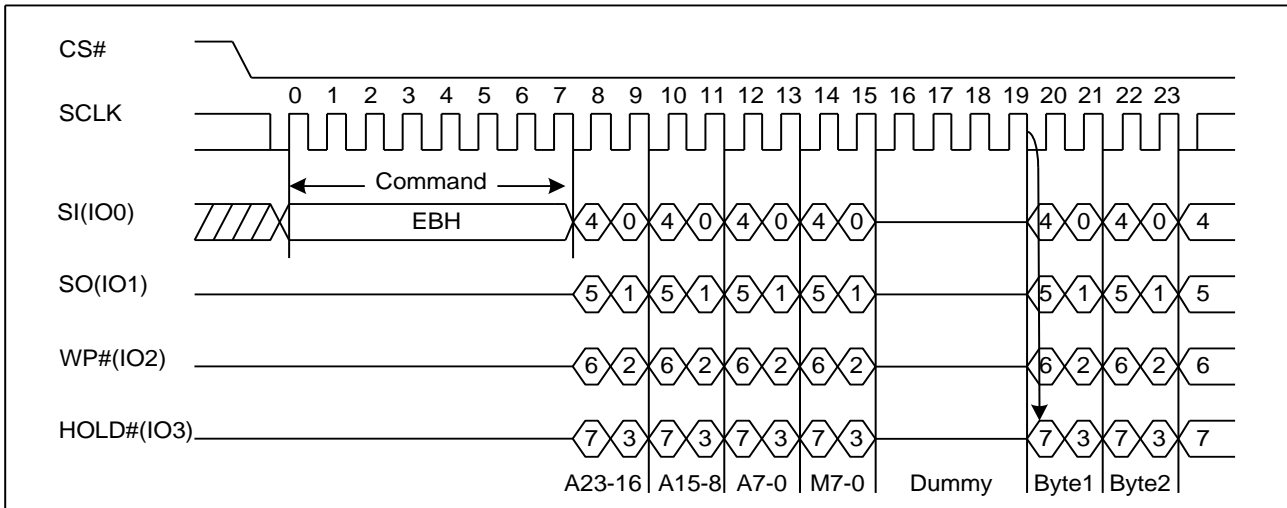
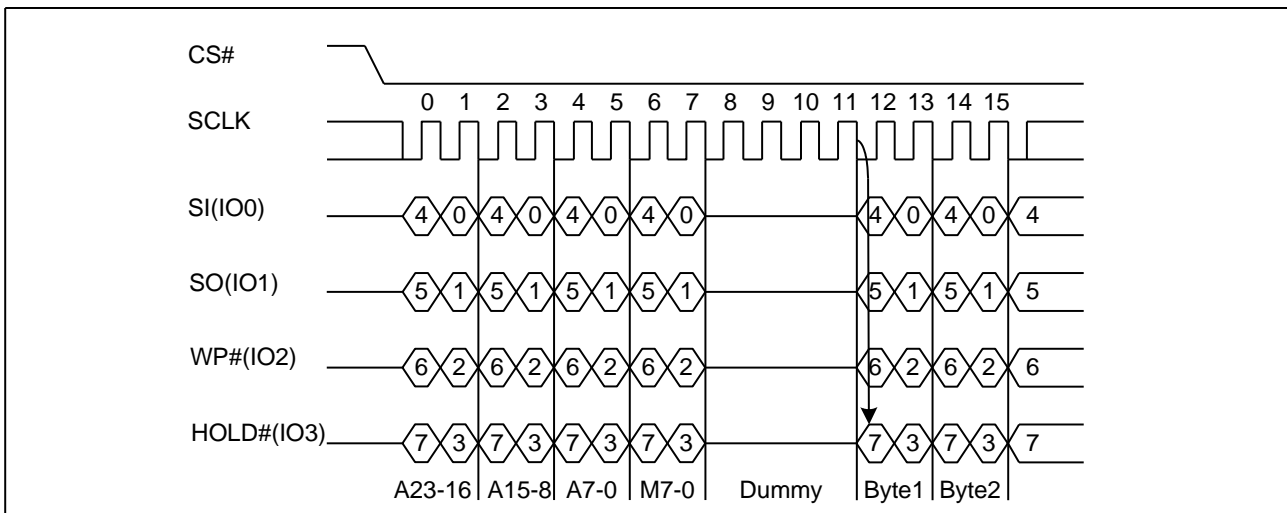

Figure13a. Quad I/O Fast Read Sequence Diagram (M5-4= (1, 0))



Quad I/O Fast Read with “8/16/32/64-Byte Wrap Around” in Standard SPI Mode

The Quad I/O Fast Read command can be used to access a specific portion within a page by issuing “Set Burst with Wrap” (77H) commands prior to EBH. The “Set Burst with Wrap” (77H) command can either enable or disable the “Wrap Around” feature for the following EBH commands. When “Wrap Around” is enabled, the data being accessed can be limited to either an 8/16/32/64-byte section of a 256-byte page. The output data starts at the initial address specified in the command, once it reaches the ending boundary of the 8/16/32/64-byte section, the output will wrap around the beginning boundary automatically until CS# is pulled high to terminate the command.

The Burst with Wrap feature allows applications that use cache to quickly fetch a critical address and then fill the cache

afterwards within a fixed length (8/16/32/64-byte) of data without issuing multiple read commands. The “Set Burst with Wrap” command allows three “Wrap Bits” W6-W4 to be set. The W4 bit is used to enable or disable the “Wrap Around” operation while W6-W5 is used to specify the length of the wrap around section within a page.

7.12. Set Burst with Wrap (77H)

The Set Burst with Wrap command is used in conjunction with “Quad I/O Fast Read” and “Quad I/O Word Fast Read” command to access a fixed length of 8/16/32/64-byte section within a 256-byte page.

The Set Burst with Wrap command sequence: CS# goes low → Send Set Burst with Wrap command → Send 24 dummy bits → Send 8 bits “Wrap bits” → CS# goes high.

W6,W5	W4=0		W4=1 (default)	
	Wrap Around	Wrap Length	Wrap Around	Wrap Length
0, 0	Yes	8-byte	No	N/A
0, 1	Yes	16-byte	No	N/A
1, 0	Yes	32-byte	No	N/A
1, 1	Yes	64-byte	No	N/A

If the W6-W4 bits are set by the Set Burst with Wrap command, all the following “Quad I/O Fast Read” and “Quad I/O Word Fast Read” command will use the W6-W4 setting to access the 8/16/32/64-byte section within any page. To exit the “Wrap Around” function and return to normal read operation, another Set Burst with Wrap command should be issued to set W4=1.

Figure14. Set Burst with Wrap Sequence Diagram

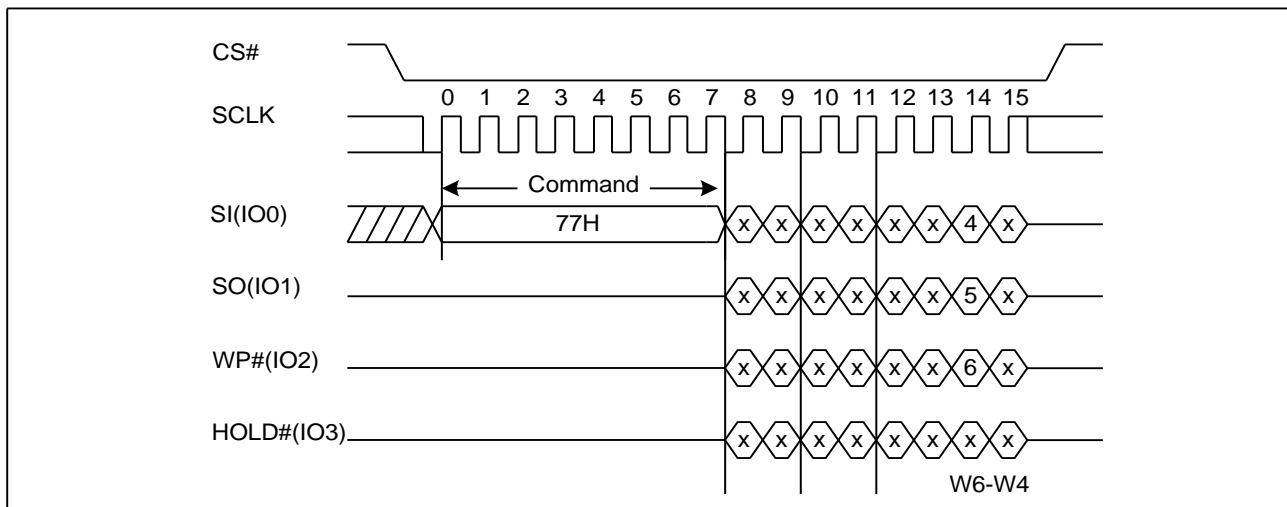

7.13. Page Program (PP) (02H)

The Page Program (PP) command is for programming the memory. A Write Enable (WREN) command must previously have been executed to set the Write Enable Latch (WEL) bit before sending the Page Program command.

The Page Program (PP) command is entered by driving CS# Low, followed by the command code, three address bytes and at least one data byte on SI. If the 8 least significant address bits (A7-A0) are not all zero, all transmitted data that goes beyond the end of the current page are programmed from the start address of the same page (from the address whose 8 least significant bits (A7-A0) are all zero). CS# must be driven low for the entire duration of the sequence. The Page Program command sequence: CS# goes low → sending Page Program command → 3-byte address on SI → at least

1 byte data on SI → CS# goes high. The command sequence is shown in Figure15. If more than 256 bytes are sent to the device, previously latched data are discarded and the last 256 data bytes are guaranteed to be programmed correctly within the same page. If less than 256 data bytes are sent to device, they are correctly programmed at the requested addresses without having any effects on the other bytes of the same page. CS# must be driven high after the eighth bit of the last data byte has been latched in; otherwise the Page Program (PP) command is not executed.

As soon as CS# is driven high, the self-timed Page Program cycle (whose duration is t_{PP}) is initiated. While the Page Program cycle is in progress, the Status Register may be read to check the value of the Write in Progress (WIP) bit. The Write in Progress (WIP) bit is 1 during the self-timed Page Program cycle, and is 0 when it is completed. At some unspecified time before the cycle is completed, the Write Enable Latch (WEL) bit is reset.

A Page Program (PP) command applied to a page which is protected by the Block Protect (BP4, BP3, BP2, BP1, and BP0) is not executed.

Figure15. Page Program Sequence Diagram

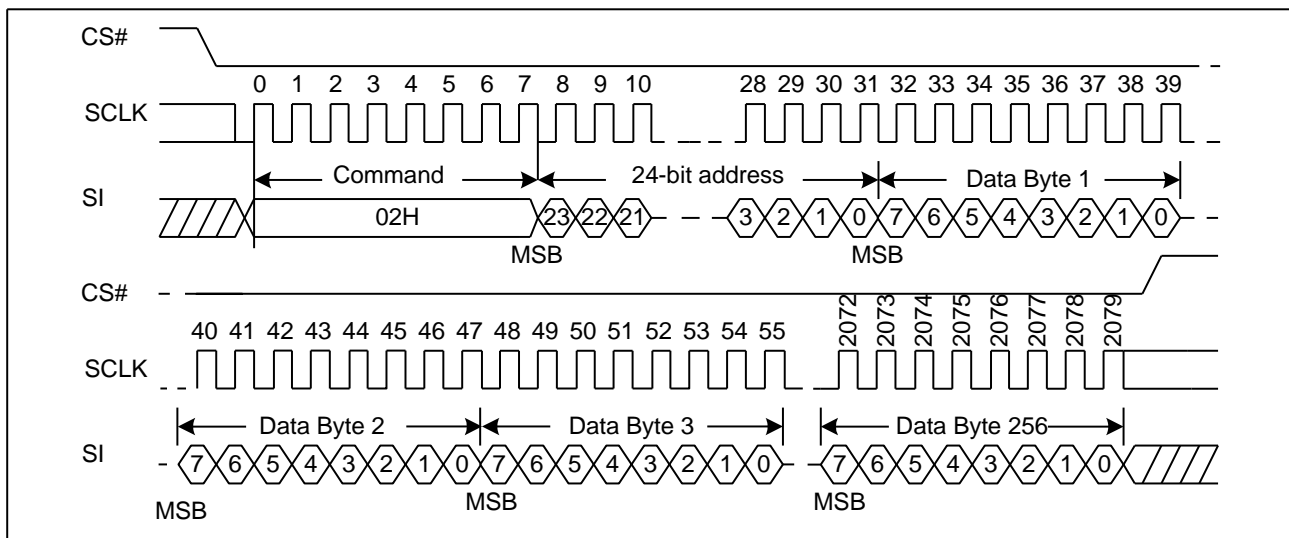

7.14. Quad Page Program (32H)

The Quad Page Program command is for programming the memory using four pins: IO0, IO1, IO2, and IO3. To use Quad Page Program the Quad enable in status register Bit9 must be set (QE=1). A Write Enable (WREN) command must previously have been executed to set the Write Enable Latch (WEL) bit before sending the Page Program command. The quad Page Program command is entered by driving CS# Low, followed by the command code (32H), three address bytes and at least one data byte on IO pins.

The command sequence is shown in Figure16. If more than 256 bytes are sent to the device, previously latched data are discarded and the last 256 data bytes are guaranteed to be programmed correctly within the same page. If less than 256 data bytes are sent to device, they are correctly programmed at the requested addresses without having any effects on the other bytes of the same page. CS# must be driven high after the eighth bit of the last data byte has been latched in; otherwise the Quad Page Program (PP) command is not executed.

As soon as CS# is driven high, the self-timed Quad Page Program cycle (whose duration is t_{PP}) is initiated. While the Quad Page Program cycle is in progress, the Status Register may be read to check the value of the Write In Progress (WIP) bit. The Write in Progress (WIP) bit is 1 during the self-timed Quad Page Program cycle, and is 0 when it is completed. At some unspecified time before the cycle is completed, the Write Enable Latch (WEL) bit is reset.

A Quad Page Program command applied to a page which is protected by the Block Protect (BP4, BP3, BP2, BP1, and BP0) is not executed.

Figure16. Quad Page Program Sequence Diagram

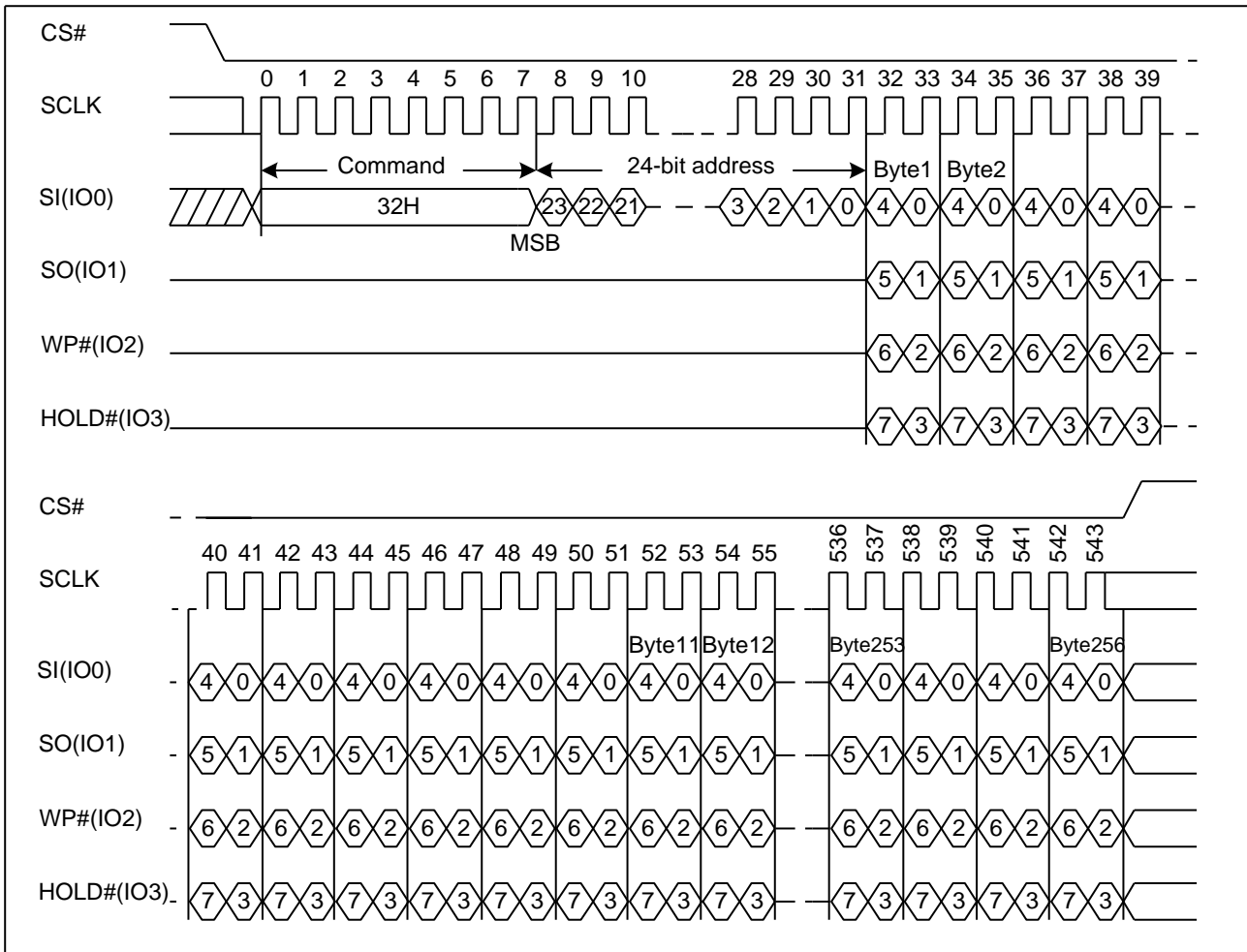

7.15. Sector Erase (SE) (20H)

The Sector Erase (SE) command is used to erase all data of the chosen sector. A Write Enable (WREN) command must previously have been executed to set the Write Enable Latch (WEL) bit. The Sector Erase (SE) command is entered by driving CS# low, followed by the command code, and 3-address bytes on SI. Any address inside the sector is a valid address for the Sector Erase (SE) command. CS# must be driven low for the entire duration of the sequence.

The Sector Erase command sequence: CS# goes low → sending Sector Erase command → 3-byte address on SI → CS# goes high. The command sequence is shown in Figure17. CS# must be driven high after the eighth bit of the last address byte has been latched in; otherwise the Sector Erase (SE) command is not executed. As soon as CS# is driven high, the self-timed Sector Erase cycle (whose duration is t_{SE}) is initiated. While the Sector Erase cycle is in progress, the Status Register may be read to check the value of the Write in Progress (WIP) bit. The Write in Progress (WIP) bit is 1 during the self-timed Sector Erase cycle, and is 0 when it is completed. At some unspecified time before the cycle is completed, the Write Enable Latch (WEL) bit is reset. A Sector Erase (SE) command applied to a sector which is protected by the Block Protect (BP4, BP3, BP2, BP1, and BP0) bit is not executed.

Figure17. Sector Erase Sequence Diagram

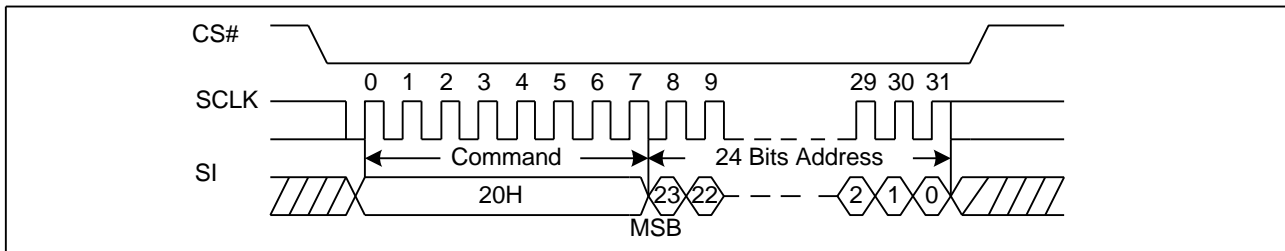

7.16. 32KB Block Erase (BE) (52H)

The 32KB Block Erase (BE) command is used to erase all data of the chosen block. A Write Enable (WREN) command must previously have been executed to set the Write Enable Latch (WEL) bit. The 32KB Block Erase (BE) command is entered by driving CS# low, followed by the command code, and three address bytes on SI. Any address inside the block is a valid address for the 32KB Block Erase (BE) command. CS# must be driven low for the entire duration of the sequence.

The 32KB Block Erase command sequence: CS# goes low → sending 32KB Block Erase command → 3-byte address on SI → CS# goes high. The command sequence is shown in Figure18. CS# must be driven high after the eighth bit of the last address byte has been latched in; otherwise the 32KB Block Erase (BE) command is not executed. As soon as CS# is driven high, the self-timed Block Erase cycle (whose duration is t_{BE}) is initiated. While the Block Erase cycle is in progress, the Status Register may be read to check the value of the Write in Progress (WIP) bit. The Write in Progress (WIP) bit is 1 during the self-timed Block Erase cycle, and is 0 when it is completed. At some unspecified time before the cycle is completed, the Write Enable Latch (WEL) bit is reset. A 32KB Block Erase (BE) command applied to a block which is protected by the Block Protect (BP4, BP3, BP2, BP1, and BP0) bits is not executed.

Figure18. 32KB Block Erase Sequence Diagram

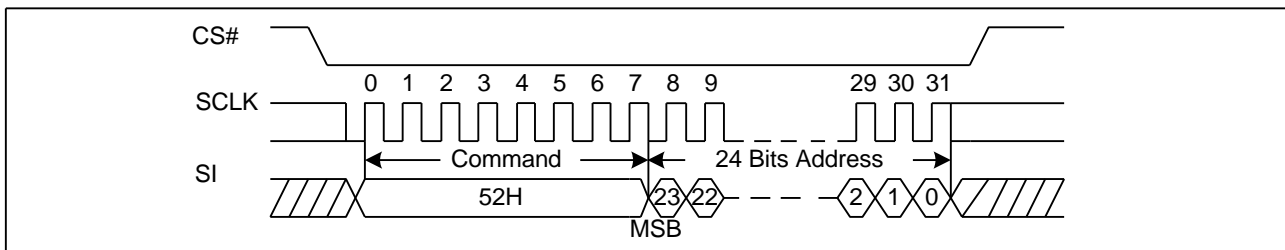

7.17. 64KB Block Erase (BE) (D8H)

The 64KB Block Erase (BE) command is used to erase all data of the chosen block. A Write Enable (WREN) command must previously have been executed to set the Write Enable Latch (WEL) bit. The 64KB Block Erase (BE) command is entered by driving CS# low, followed by the command code, and three address bytes on SI. Any address inside the block is a valid address for the 64KB Block Erase (BE) command. CS# must be driven low for the entire duration of the sequence.

The 64KB Block Erase command sequence: CS# goes low → sending 64KB Block Erase command → 3-byte address on SI → CS# goes high. The command sequence is shown in Figure19. CS# must be driven high after the eighth bit of the last address byte has been latched in; otherwise the 64KB Block Erase (BE) command is not executed. As soon as CS# is driven high, the self-timed Block Erase cycle (whose duration is t_{BE}) is initiated. While the Block Erase cycle is in progress, the Status Register may be read to check the value of the Write in Progress (WIP) bit. The Write in Progress (WIP) bit is 1 during the self-timed Block Erase cycle, and is 0 when it is completed. At some unspecified time before the cycle is completed, the Write Enable Latch (WEL) bit is reset. A 64KB Block Erase (BE) command applied to a block which is protected by the Block Protect (BP4, BP3, BP2, BP1, and BP0) bits is not executed.

Figure19. 64KB Block Erase Sequence Diagram

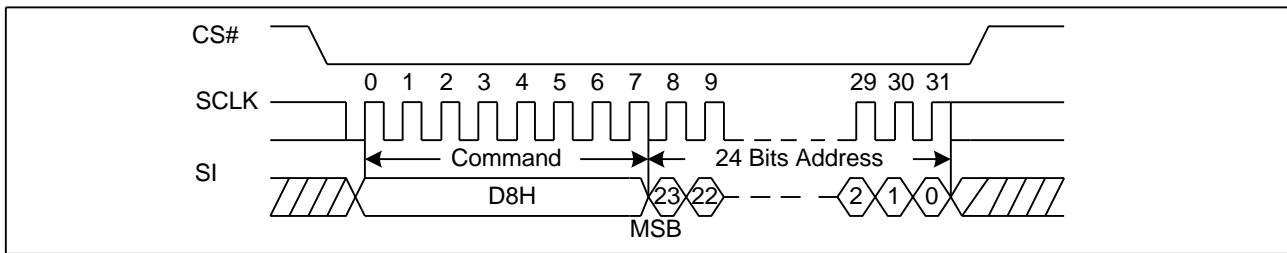

7.18. Chip Erase (CE) (60/C7H)

The Chip Erase (CE) command is used to erase all data of the chip. A Write Enable (WREN) command must previously have been executed to set the Write Enable Latch (WEL) bit. The Chip Erase (CE) command is entered by driving CS# Low, followed by the command code on Serial Data Input (SI). CS# must be driven Low for the entire duration of the sequence.

The Chip Erase command sequence: CS# goes low → sending Chip Erase command → CS# goes high. The command sequence is shown in Figure20. CS# must be driven high after the eighth bit of the command code has been latched in; otherwise the Chip Erase command is not executed. As soon as CS# is driven high, the self-timed Chip Erase cycle (whose duration is t_{CE}) is initiated. While the Chip Erase cycle is in progress, the Status Register may be read to check the value of the Write in Progress (WIP) bit. The Write in Progress (WIP) bit is 1 during the self-timed Chip Erase cycle, and is 0 when it is completed. At some unspecified time before the cycle is completed, the Write Enable Latch (WEL) bit is reset. The Chip Erase (CE) command is executed if the Block Protect (BP2, BP1, and BP0) bits are 0 and CMP=0 or the Block Protect (BP2, BP1, and BP0) bits are 1 and CMP=1. The Chip Erase (CE) command is ignored if one or more sectors are protected.

Figure20. Chip Erase Sequence Diagram

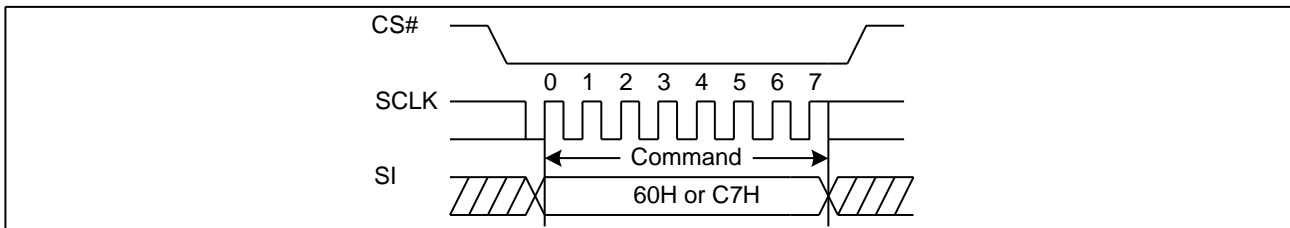

7.19. Deep Power-Down (DP) (B9H)

Executing the Deep Power-Down (DP) command is the only way to put the device in the lowest consumption mode (the Deep Power-Down Mode). It can also be used as an extra software protection mechanism, while the device is not in active use, since in this mode, the device ignores all Write, Program and Erase commands. Driving CS# high deselected the device, and puts the device in the Standby Mode (if there is no internal cycle currently in progress). But this mode is not the Deep Power-Down Mode. The Deep Power-Down Mode can only be entered by executing the Deep Power-Down (DP) command. Once the device has entered the Deep Power-Down Mode, all commands are ignored except the Release from Deep Power-Down and Read Device ID (RDI) (ABH) or Enable Reset (66H) and Reset (99H) commands. These commands can release the device from this mode. The Release from Deep Power-Down and Read Device ID (RDI) command releases the device from deep power down mode, also allows the Device ID of the device to be output on SO.

The Deep Power-Down Mode automatically stops at Power-Down, and the device is in the Standby Mode after Power-Up. The Deep Power-Down (DP) command is entered by driving CS# low, followed by the command code on SI. CS# must be driven low for the entire duration of the sequence.

The Deep Power-Down command sequence: CS# goes low → sending Deep Power-Down command → CS# goes

high. The command sequence is shown in Figure21. CS# must be driven high after the eighth bit of the command code has been latched in; otherwise the Deep Power-Down (DP) command is not executed. As soon as CS# is driven high, it requires a delay of t_{DP} before the supply current is reduced to I_{CC2} and the Deep Power-Down Mode is entered. Any Deep Power-Down (DP) command, while an Erase, Program or Write cycle is in progress, is rejected without having any effects on the cycle that is in progress.

Figure21. Deep Power-Down Sequence Diagram

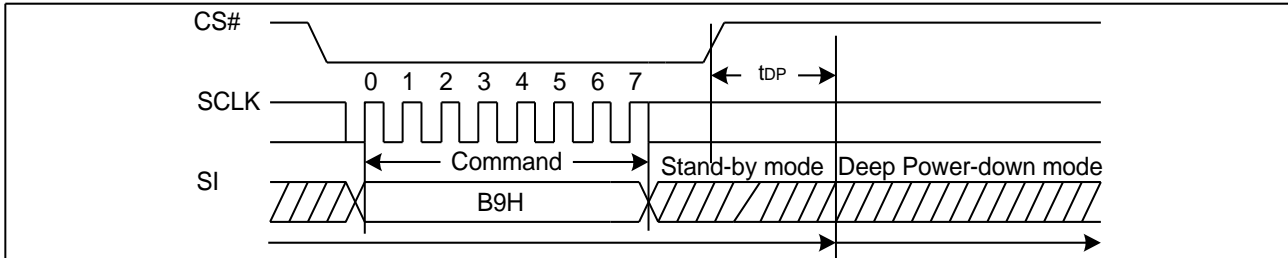

7.20. Release from Deep Power-Down and Read Device ID (RDI) (ABH)

The Release from Power-Down and Read Device ID command is a multi-purpose command. It can be used to release the device from the Power-Down state or obtain the devices electronic identification (ID) number.

To release the device from the Power-Down state, the command is issued by driving the CS# pin low, shifting the instruction code "ABH" and driving CS# high as shown below. Release from Power-Down will take the time duration of t_{RES1} (See AC Characteristics) before the device will resume normal operation and other command are accepted. The CS# pin must remain high during the t_{RES1} time duration.

When used only to obtain the Device ID while not in the Power-Down state, the command is initiated by driving the CS# pin low and shifting the instruction code "ABH" followed by 3-dummy byte. The Device ID bits are then shifted out on the falling edge of SCLK with most significant bit (MSB) first as shown below. The Device ID value is listed in Manufacturer and Device Identification table. The Device ID can be read continuously. The command is completed by driving CS# high.

When used to release the device from the Power-Down state and obtain the Device ID, the command is the same as previously described, except that after CS# is driven high it must remain high for a time duration of t_{RES2} (See AC Characteristics). After this time duration the device will resume normal operation and other command will be accepted. If the Release from Power-Down / Device ID command is issued while an Erase, Program or Write cycle is in process (when WIP equal 1) the command is ignored and will not have any effects on the current cycle.

Figure22. Release Power-Down Sequence Diagram

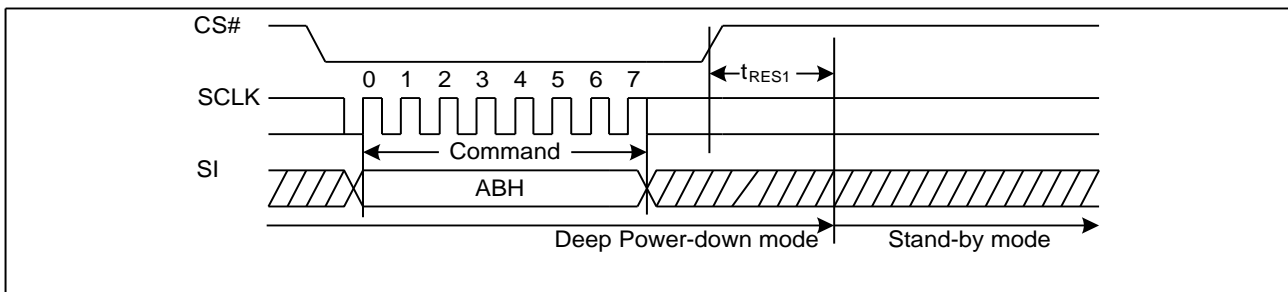
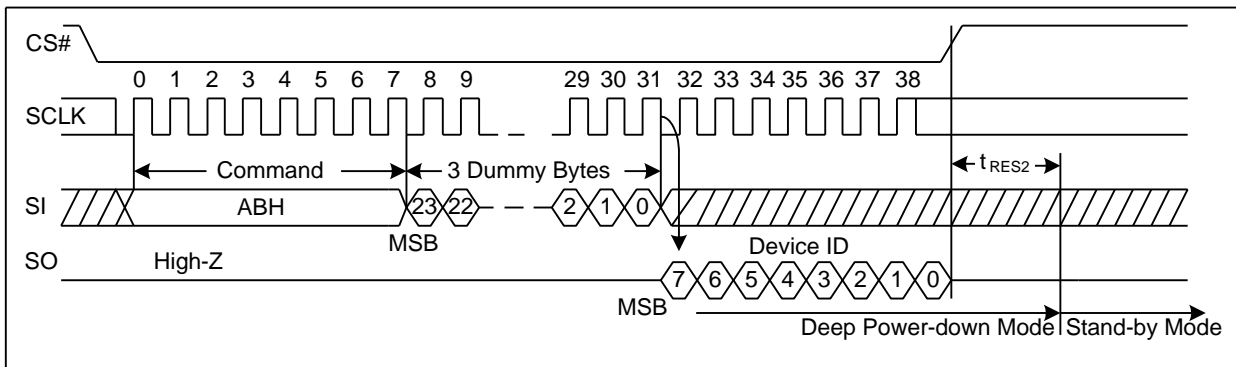

Figure23. Release Power-Down/Read Device ID Sequence Diagram



7.21. Read Manufacture ID/ Device ID (REMS) (90H)

The Read Manufacturer/Device ID command is an alternative to the Release from Power-Down / Device ID command that provides both the JEDEC assigned Manufacturer ID and the specific Device ID.

The command is initiated by driving the CS# pin low and shifting the command code "90H" followed by a 24-bit address (A23-A0) of 000000H. After which, the Manufacturer ID and the Device ID are shifted out on the falling edge of SCLK with most significant bit (MSB) first as shown in Figure24. If the 24-bit address is initially set to 000001H, the Device ID will be read first.

Figure24. Read Manufacture ID/ Device ID Sequence Diagram

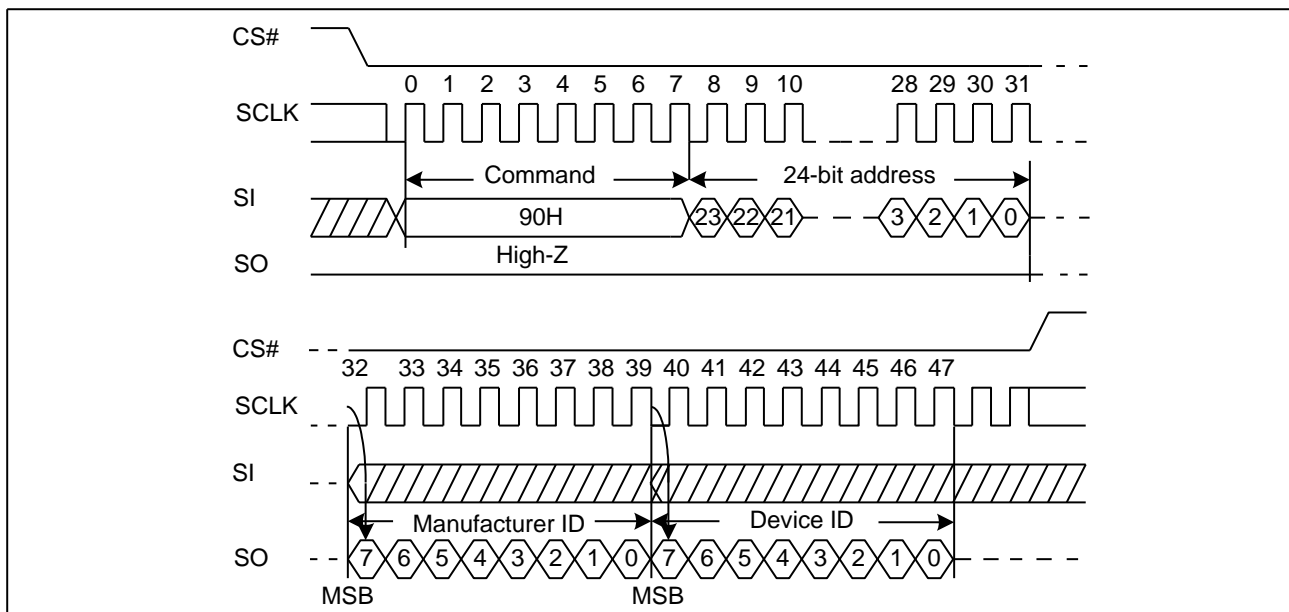

7.22. Read Identification (RDID) (9FH)

The Read Identification (RDID) command allows the 8-bit manufacturer identification to be read, followed by two bytes of device identification. The device identification indicates the memory type in the first byte, and the memory capacity of the device in the second byte. The Read Identification (RDID) command while an Erase or Program cycle is in progress is not decoded, and has no effect on the cycle that is in progress. The Read Identification (RDID) command should not be issued while the device is in Deep Power-Down Mode.

The device is first selected by driving CS# low. Then, the 8-bit command code for the command is shifted in. This is followed by the 24-bit device identification, stored in the memory. Each bit is shifted out on the falling edge of Serial Clock. The command sequence is shown in Figure25. The Read Identification (RDID) command is terminated by driving CS# high at any time during data output. When CS# is driven high, the device is in the Standby Mode. Once in the Standby Mode, the device waits to be selected, so that it can receive, decode and execute commands.

Figure25. Read Identification ID Sequence Diagram

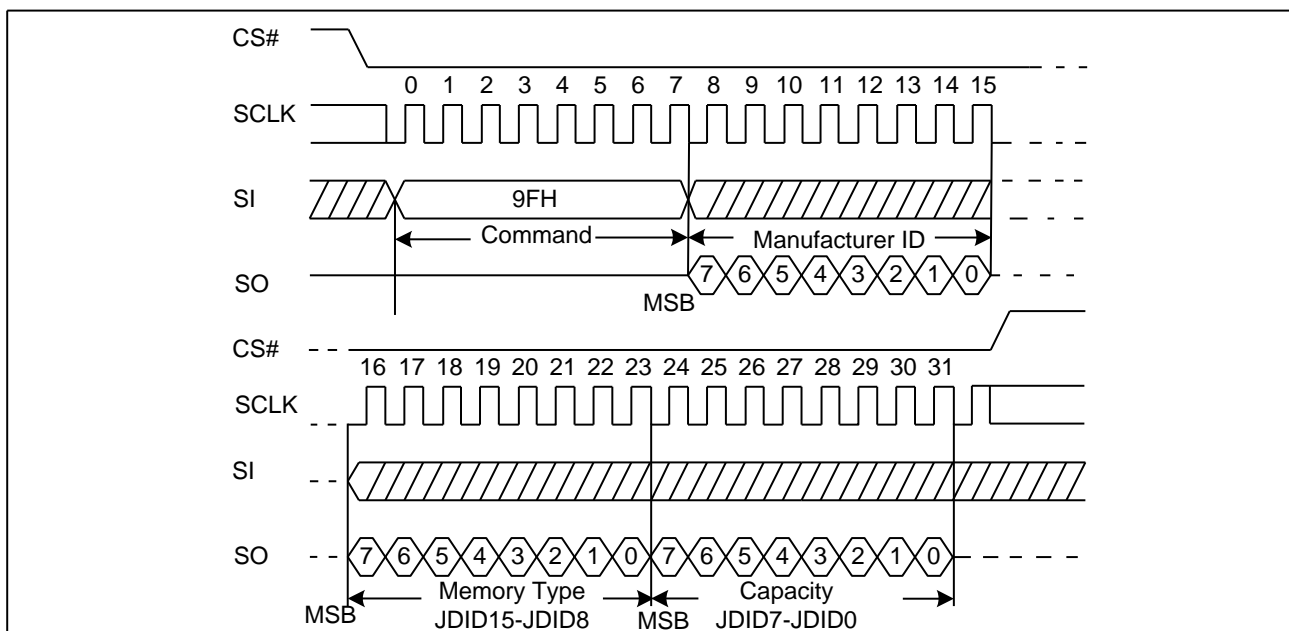

7.23. Program/Erase Suspend (PES) (75H)

The Program/Erase Suspend command "75H", allows the system to interrupt a page program or sector/block erase operation and then read data from any other sector or block. The Write Status Register command (01H/31H/11H) and Erase/Program Security Registers command (44H, 42H) and Erase commands (20H, 52H, D8H, C7H, 60H) and Page Program command (02H, 32H) are not allowed during Program suspend. The Write Status Register command (01H/31H/11H) and Erase Security Registers command (44H) and Erase commands (20H, 52H, D8H, C7H, 60H) are not allowed during Erase suspend. Program/Erase Suspend is valid only during the page program or sector/block erase operation. A maximum of time of "tsus" (See AC Characteristics) is required to suspend the program/erase operation.

The Program/Erase Suspend command will be accepted by the device only if the SUS2/SUS1 bit in the Status Register equal to 0 and WIP bit equal to 1 while a Page Program or a Sector or Block Erase operation is on-going. If the SUS2/SUS1 bit equal to 1 or WIP bit equal to 0, the Suspend command will be ignored by the device. The WIP bit will be cleared from 1 to 0 within "tsus" and the SUS2/SUS1 bit will be set from 0 to 1 immediately after Program/Erase Suspend. A power-off during the suspend period will reset the device and release the suspend state. The command sequence is show in Figure26.

Figure26. Program/Erase Suspend Sequence Diagram

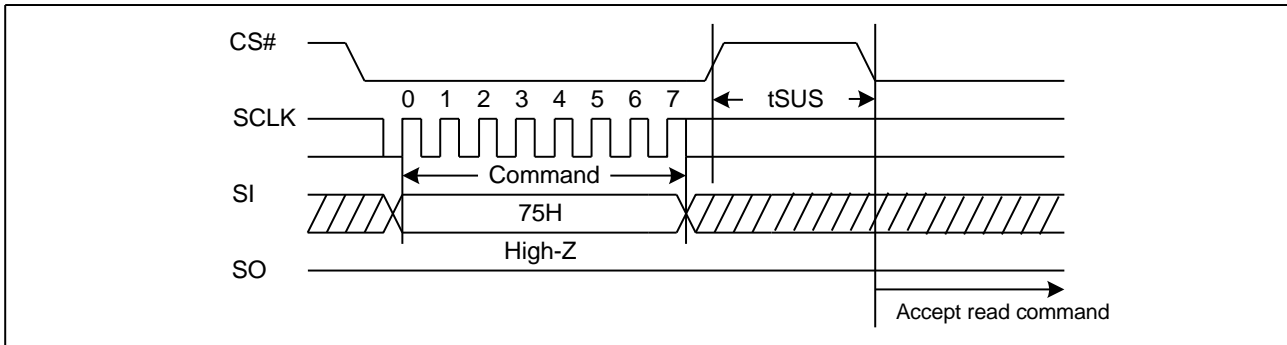

7.24. Program/Erase Resume (PER) (7AH)

The Program/Erase Resume command must be written to resume the program or sector/block erase operation after a Program/Erase Suspend command. The Program/Erase command will be accepted by the device only if the SUS2/SUS1 bit equal to 1 and the WIP bit equal to 0. After issued the SUS2/SUS1 bit in the status register will be cleared from 1 to 0 immediately, the WIP bit will be set from 0 to 1 within 200ns and the Sector or Block will complete the erase operation or the page will complete the program operation. The Program/Erase Resume command will be ignored unless a Program/Erase Suspend is active. The command sequence is show in Figure27.

Figure27. Program/Erase Resume Sequence Diagram

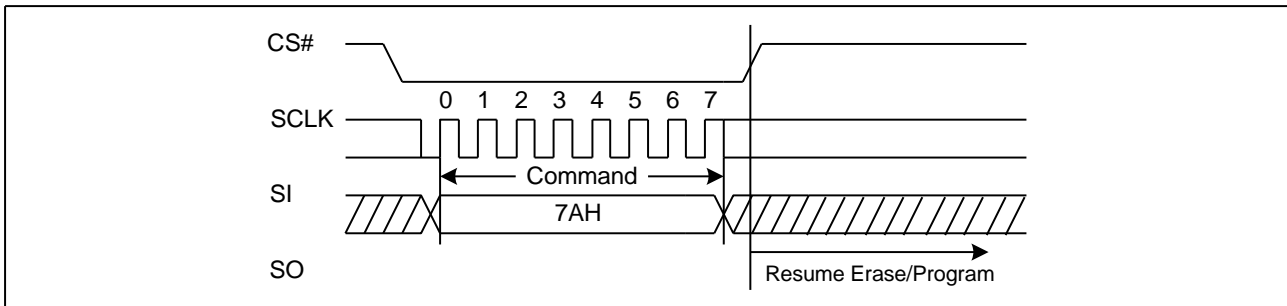

7.25. Erase Security Registers (44H)

The MD25Q128 provides three 1024-byte Security Registers which can be erased and programmed individually. These registers may be used by the system manufacturers to store security and other important information separately from the main memory array.

The Erase Security Registers command is similar to Sector/Block Erase command. A Write Enable (WREN) command must previously have been executed to set the Write Enable Latch (WEL) bit.

The Erase Security Registers command sequence: CS# goes low → sending Erase Security Registers command → CS# goes high. The command sequence is shown in Figure28. CS# must be driven high after the eighth bit of the command code has been latched in; otherwise the Erase Security Registers command is not executed. As soon as CS# is driven high, the self-timed Erase Security Registers cycle (whose duration is t_{SE}) is initiated. While the Erase Security Registers cycle is in progress, the Status Register may be read to check the value of the Write in Progress (WIP) bit. The Write in Progress (WIP) bit is 1 during the self-timed Erase Security Registers cycle, and is 0 when it is completed. At some unspecified time before the cycle is completed, the Write Enable Latch (WEL) bit is reset. The Security Registers Lock Bit (LB3-1) in the Status Register can be used to OTP protect the security registers. Once the LB bit is set to 1, the Security Registers will be permanently locked; the Erase Security Registers command will be ignored.

Address	A23-16	A15-12	A11-10	A9-0
Security Register #1	00H	0 0 1	0 0	Don't care
Security Register #2	00H	0 0 1 0	0 0	Don't care
Security Register #3	00H	0 0 1 1	0 0	Don't care

Figure28. Erase Security Registers command Sequence Diagram

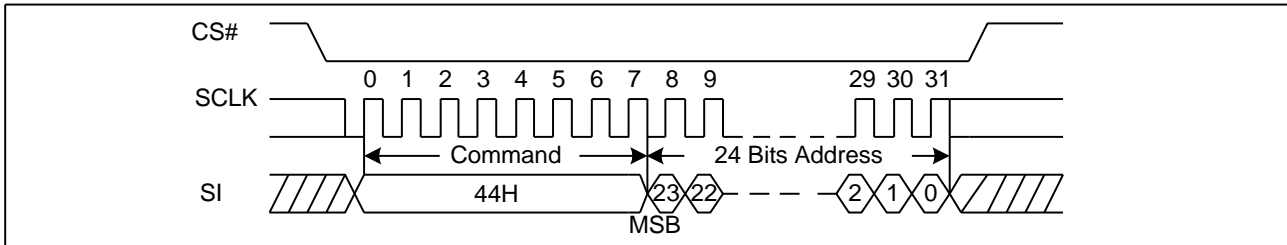

7.26. Program Security Registers (42H)

The Program Security Registers command is similar to the Page Program command. It allows from 1 to 1024 bytes Security Registers data to be programmed. A Write Enable (WREN) command must previously have been executed to set the Write Enable Latch (WEL) bit before sending the Program Security Registers command. The Program Security Registers command is entered by driving CS# Low, followed by the command code (42H), three address bytes and at least one data byte on SI. As soon as CS# is driven high, the self-timed Program Security Registers cycle (whose duration is t_{PP}) is initiated. While the Program Security Registers cycle is in progress, the Status Register may be read to check the value of the Write in Progress (WIP) bit. The Write in Progress (WIP) bit is 1 during the self-timed Program Security Registers cycle, and is 0 when it is completed. At some unspecified time before the cycle is completed, the Write Enable Latch (WEL) bit is reset.

If the Security Registers Lock Bit (LB3-1) is set to 1, the Security Registers will be permanently locked. Program Security Registers command will be ignored.

Address	A23-16	A15-12	A11-10	A9-0
Security Register #1	00H	0 0 1	0 0	Byte Address
Security Register #2	00H	0 0 1 0	0 0	Byte Address
Security Register #3	00H	0 0 1 1	0 0	Byte Address

Figure29. Program Security Registers command Sequence Diagram

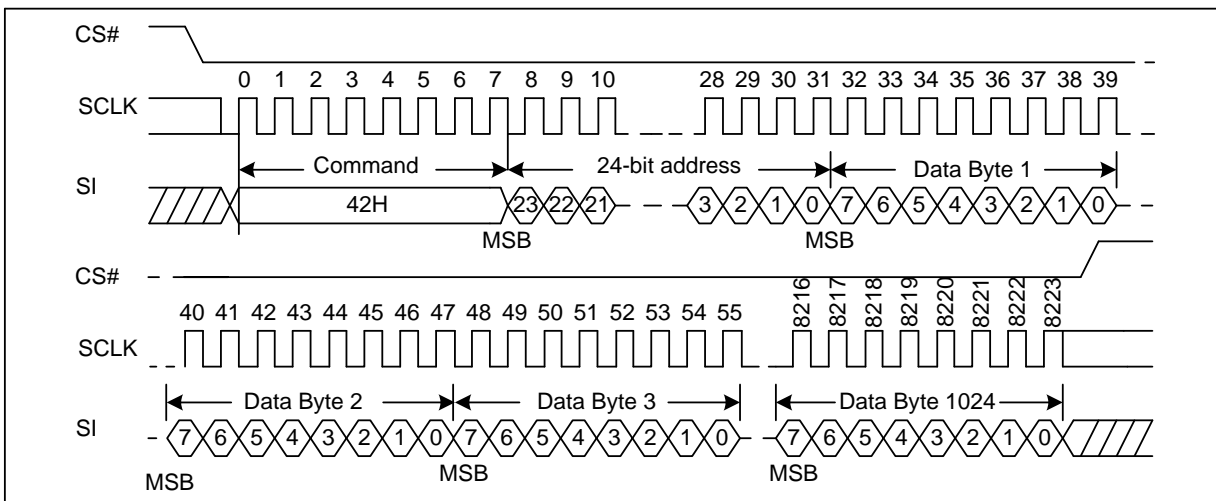

7.27. Read Security Registers (48H)

The Read Security Registers command is similar to Fast Read command. The command is followed by a 3-byte address (A23-A0) and a dummy byte, each bit being latched-in during the rising edge of SCLK. Then the memory content, at that address, is shifted out on SO, each bit being shifted out, at a Max frequency f_C , during the falling edge of SCLK. The first byte addressed can be at any location. The address is automatically incremented to the next higher address after each byte of data is shifted out. Once the A9-A0 address reaches the last byte of the register (Byte 3FFH), it will reset to 000H, the command is completed by driving CS# high.

Address	A23-16	A15-12	A11-10	A9-0
Security Register #1	00H	0 0 0 1	0 0	Byte Address
Security Register #2	00H	0 0 1 0	0 0	Byte Address
Security Register #3	00H	0 0 1 1	0 0	Byte Address

Figure30. Read Security Registers command Sequence Diagram

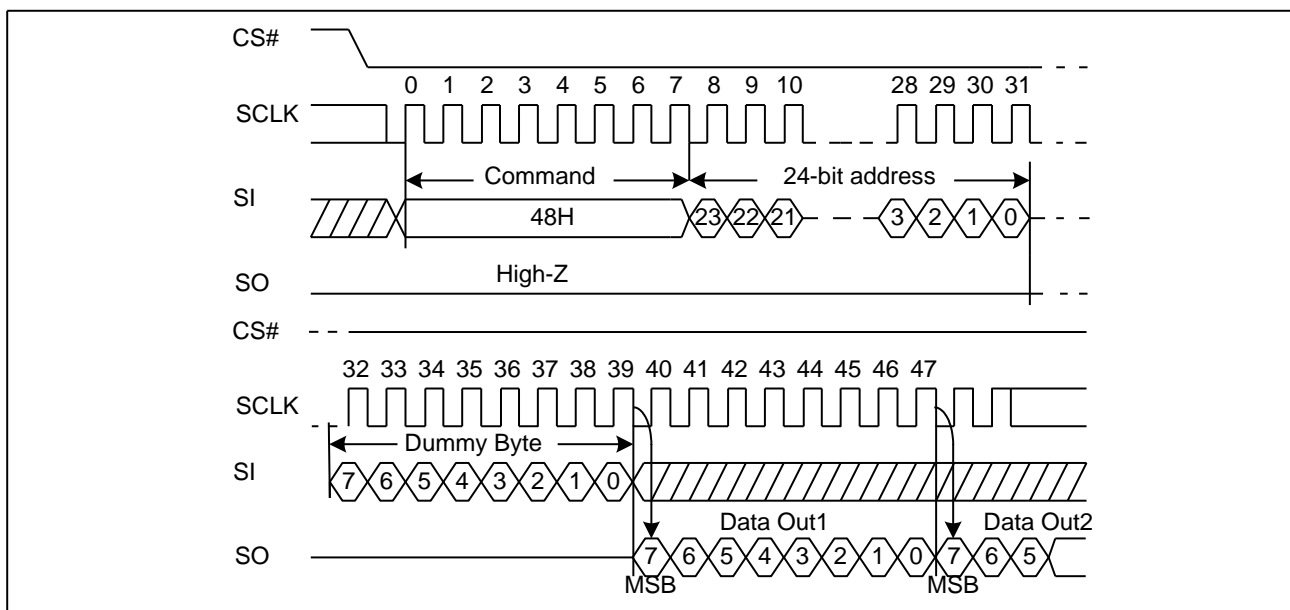
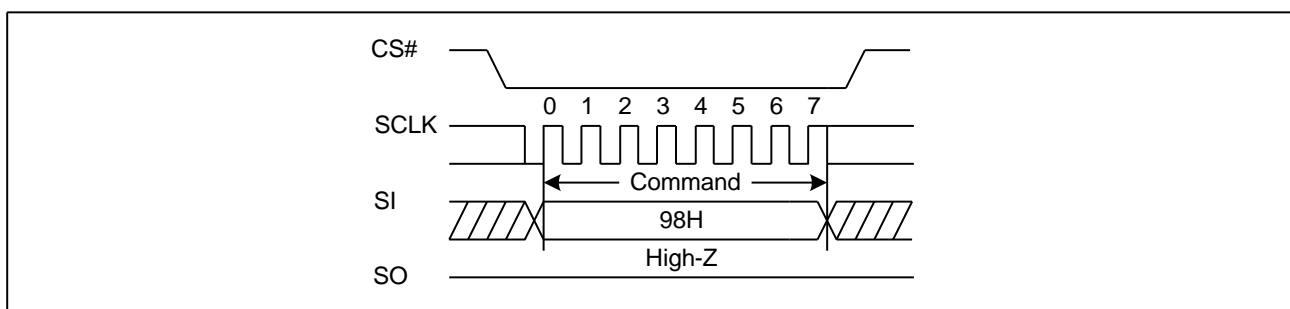

Figure31. The Global Block/Sector Unlock Sequence Diagram



7.28. Enable Reset (66H) and Reset (99H)

If the Reset command is accepted, any on-going internal operation will be terminated and the device will return to its default power-on state and lose all the current volatile settings, such as Volatile Status Register bits, Write Enable Latch status (WEL), Program/Erase Suspend status, Read Parameter setting (P7-P0), Continuous Read Mode bit setting (M7-M0) and Wrap Bit Setting (W6-W4).

The "Enable Reset (66H)" and the "Reset (99H)" commands can be issued in either SPI mode. The "Reset (99H)"

command sequence as follow: CS# goes low → Sending Enable Reset command → CS# goes high → CS# goes low → Sending Reset command → CS# goes high. Once the Reset command is accepted by the device, the device will take approximately t_{RST} / t_{RST_E} to reset. During this period, no command will be accepted. Data corruption may happen if there is an on-going or suspended internal Erase or Program operation when Reset command sequence is accepted by the device. It is recommended to check the BUSY bit and the SUS bit in Status Register before issuing the Reset command sequence.

Figure32. Enable Reset and Reset command Sequence Diagram

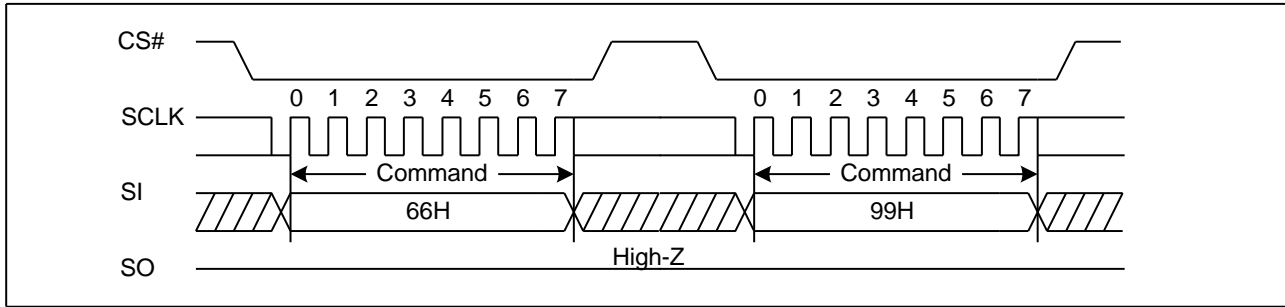

8. ELECTRICAL CHARACTERISTICS

8.1. POWER-ON TIMING

Figure 33. Power-on Timing Sequence Diagram

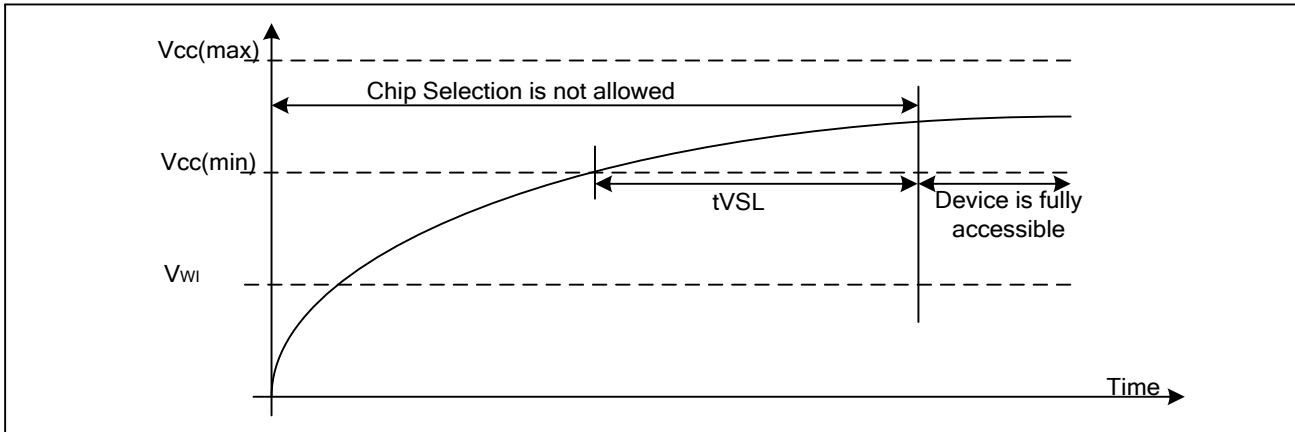

Table 8.1. Power-Up Timing and Write Inhibit Threshold

Symbol	Parameter	Min	Max	Unit
tVSL	VCC (min) To CS# Low	5		ms
VWI	Write Inhibit Voltage	1.5	2.5	V

8.2. INITIAL DELIVERY STATE

The device is delivered with the memory array erased: all bits are set to 1 (each byte contains FFH). The Status Register bits are set to 0, except DRV1 bit (S22) is set to 1.

8.3. ABSOLUTE MAXIMUM RATINGS

Parameter	Value	Unit
Ambient Operating Temperature	-40 to 85	°C
Storage Temperature	-65 to 150	°C
Applied Input/Output Voltage	-0.6 to VCC+0.4	V
Transient Input/Output Voltage (note : overshoot)	-2.0 to VCC+2.0	V
VCC	-0.6 to 4.2	V

Figure 34. Maximum Negative/positive Overshoot Diagram

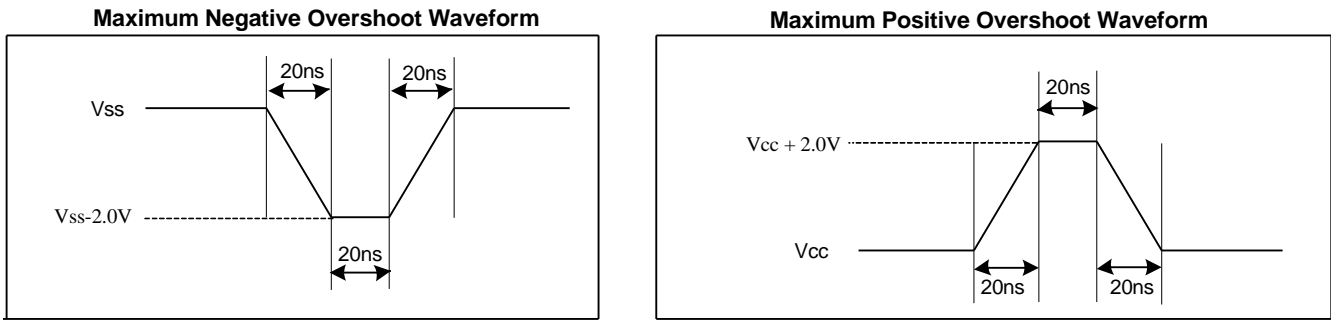

8.4. CAPACITANCE MEASUREMENT CONDITIONS

Symbol	Parameter	Min	Typ.	Max	Unit	Conditions
CIN	Input Capacitance			6	pF	VIN=0V
COUT	Output Capacitance			8	pF	VOUT=0V
CL	Load Capacitance	30			pF	
	Input Rise And Fall time			5	ns	
	Input Pulse Voltage	0.1VCC to 0.8VCC			V	
	Input Timing Reference Voltage	0.2VCC to 0.7VCC			V	
	Output Timing Reference Voltage	0.5VCC			V	

Figure 35. Input Test Waveform and Measurement Level

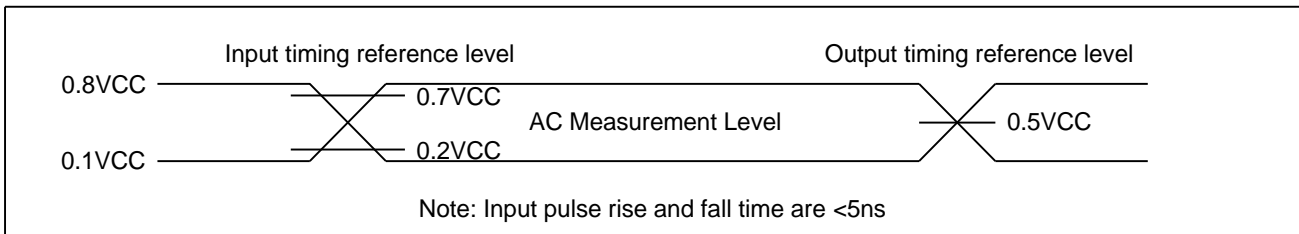

8.5. DC CHARACTERISTICS

(T= -40°C~85°C, VCC=2.7~3.6V, Normal Mode)

Symbol	Parameter	Test Condition	Min.	Typ.	Max.	Unit.
I _{LI}	Input Leakage Current				±2	μA
I _{LO}	Output Leakage Current				±2	μA
I _{CC1}	Standby Current	CS#=VCC, V _{IN} =VCC or VSS		20	50	μA
I _{CC2}	Deep Power-Down Current	CS#=VCC, V _{IN} =VCC or VSS		1	5	μA
I _{CC3}	Operating Current (Read)	CLK=0.1VCC / 0.9VCC at 104MHz, Q=Open(*1 I/O)		15	20	mA
		CLK=0.1VCC / 0.9VCC at 80MHz, Q=Open(*1, *2, *4 I/O)		13	18	mA
I _{CC4}	Operating Current (PP)	CS#=VCC			25	mA
I _{CC5}	Operating Current (WRSR)	CS#=VCC			25	mA
I _{CC6}	Operating Current (SE)	CS#=VCC			25	mA
I _{CC7}	Operating Current (BE)	CS#=VCC			25	mA
I _{CC8}	Operating Current (CE)	CS#=VCC			25	mA
V _{IL}	Input Low Voltage				0.2VCC	V
V _{IH}	Input High Voltage		0.7VCC		VCC+0.4	V
V _{OL}	Output Low Voltage	I _{OL} =100μA			0.2	V
V _{OH}	Output High Voltage	I _{OH} =-100μA	VCC-0.2			V

Note:

1. Typical values given for TA=25°C. Not 100% tested.



3.3V Uniform Sector Dual and Quad Serial Flash

MD25Q128

(T= -40°C~85°C, VCC=2.7~3.6V, Low Power Mode)

Symbol	Parameter	Test Condition	Min.	Typ.	Max.	Unit.
I _{LI}	Input Leakage Current				±2	μA
I _{LO}	Output Leakage Current				±2	μA
I _{CC1}	Standby Current	CS#=VCC, V _{IN} =VCC or VSS		20	50	μA
I _{CC2}	Deep Power-Down Current	CS#=VCC, V _{IN} =VCC or VSS		0.1	5	μA
I _{CC3}	Operating Current (Read)	CLK=0.1VCC / 0.9VCC at 104MHz, Q=Open(*1 I/O)		13	18	mA
		CLK=0.1VCC / 0.9VCC at 80MHz, Q=Open(*1,*2,*4 I/O)		10	15	mA
I _{CC4}	Operating Current (PP)	CS#=VCC			15	mA
I _{CC5}	Operating Current (WRSR)	CS#=VCC			15	mA
I _{CC6}	Operating Current (SE)	CS#=VCC			15	mA
I _{CC7}	Operating Current (BE)	CS#=VCC			15	mA
I _{CC8}	Operating Current (CE)	CS#=VCC			15	mA
V _{IL}	Input Low Voltage				0.2VCC	V
V _{IH}	Input High Voltage		0.7VCC		VCC+0.4	V
V _{OL}	Output Low Voltage	I _{OL} =100uA			0.2	V
V _{OH}	Output High Voltage	I _{OH} =-100μA	VCC-0.2			V

Note:

1. Typical values given for TA=25°C. Not 100% tested.

8.6. AC CHARACTERISTICS

(T= -40°C~85°C, VCC=2.7~3.6V, CL=30pf, Normal Mode)

Symbol	Parameter	Min.	Typ.	Max.	Unit.
F _C	Serial Clock Frequency For: Fast Read(0BH), on 2.7V-3.6V power supply	DC.		104	MHz
f _{C1}	Serial Clock Frequency For: Dual Output (3BH), Quad Output (6BH), Dual I/O (BBH), Quad I/O (EBH), Quad I/O Word ,on 2.7V-3.0V power supply	DC.		80	MHz
f _{C2}	Serial Clock Frequency For: Dual Output (3BH), Quad Output (6BH), Dual I/O (BBH), Quad I/O (EBH), Quad I/O Word ,on 3.0V-3.6V power supply	DC.		104	MHz
f _R	Serial Clock Frequency For: Read (03H), Read Manufacturer ID/device ID (90H), Read Identification (9FH)	DC.		80	MHz
t _{CLH}	Serial Clock High Time	4.5			ns
t _{CLL}	Serial Clock Low Time	4.5			ns
t _{CLCH}	Serial Clock Rise Time (Slew Rate)	0.1			V/ns
t _{CHCL}	Serial Clock Fall Time (Slew Rate)	0.1			V/ns
t _{SLCH}	CS# Active Setup Time	5			ns
t _{CHSH}	CS# Active Hold Time	5			ns
t _{SHCH}	CS# Not Active Setup Time	5			ns
t _{CHSL}	CS# Not Active Hold Time	5			ns
t _{SHSL}	CS# High Time (Read/Write)	20			ns
t _{SHQZ}	Output Disable Time			6	ns
t _{CLQX}	Output Hold Time	1.0			ns
t _{DVCH}	Data In Setup Time	2			ns
t _{CHDX}	Data In Hold Time	2			ns
t _{HLCH}	HOLD# Low Setup Time (Relative To Clock)	5			ns
t _{HHCH}	HOLD# High Setup Time (Relative To Clock)	5			ns
t _{CHHL}	HOLD# High Hold Time (Relative To Clock)	5			ns
t _{CHHH}	HOLD# Low Hold Time (Relative To Clock)	5			ns
t _{HLQZ}	HOLD# Low To High-Z Output			6	ns
t _{HHQX}	HOLD# Low To Low-Z Output			6	ns
t _{CLQV}	Clock Low To Output Valid			7	ns
t _{WHSL}	Write Protect Setup Time Before CS# Low	20			ns
t _{SHWL}	Write Protect Hold Time After CS# High	100			ns
t _{DP}	CS# High To Deep Power-Down Mode			20	μs
t _{RES1}	CS# High To Standby Mode Without Electronic Signature Read			30	μs
t _{RES2}	CS# High To Standby Mode With Electronic Signature Read			30	μs
t _{SUS}	CS# High To Next Command After Suspend			20	μs
t _{RST}	CS# High To Next Command After Reset (Except From Erase)			30	μs



3.3V Uniform Sector Dual and Quad Serial Flash

MD25Q128

tRST_E	CS# High To Next Command After Reset (From Erase)			12	ms
tW	Write Status Register Cycle Time		5	30	ms
tBP1	Byte Program Time (First Byte)		30	50	μs
tBP2	Additional Byte Program Time (After First Byte)		2.5	12	μs
tPP	Page Programming Time		0.6	4	ms
tSE	Sector Erase Time		50	500	ms
tBE1	Block Erase Time (32K Bytes)		0.2	2.0	s
tBE2	Block Erase Time (64K Bytes)		0.3	2.5	s
tCE	Chip Erase Time (MD25Q128)		60	200	s

Note:

1. Typical values given for TA=25°C. Not 100% tested.



3.3V Uniform Sector Dual and Quad Serial Flash

MD25Q128

(T= -40°C~85°C, VCC=2.7~3.6V, CL=30pf, Low Power Mode)

Symbol	Parameter	Min.	Typ.	Max.	Unit.
F _C	Serial Clock Frequency For: Fast Read (0BH), on 2.7V-3.6V power supply	DC.		104	MHz
f _{C1}	Serial Clock Frequency For: Dual Output (3BH), Quad Output (6BH), Dual I/O (BBH), Quad I/O (EBH), Quad I/O Word, on 2.7V-3.0V power supply	DC.		80	MHz
f _{C2}	Serial Clock Frequency For: Dual Output (3BH), Quad Output (6BH), Dual I/O (BBH), Quad I/O (EBH), Quad I/O Word, on 3.0V-3.6V power supply	DC.		104	MHz
f _R	Serial Clock Frequency For: Read (03H), Read Manufacturer ID/device ID (90H), Read Identification (9FH)	DC.		80	MHz
t _{CLH}	Serial Clock High Time	4.5			ns
t _{CLL}	Serial Clock Low Time	4.5			ns
t _{CLCH}	Serial Clock Rise Time (Slew Rate)	0.1			V/ns
t _{CHCL}	Serial Clock Fall Time (Slew Rate)	0.1			V/ns
t _{SLCH}	CS# Active Setup Time	5			ns
t _{CHSH}	CS# Active Hold Time	5			ns
t _{SHCH}	CS# Not Active Setup Time	5			ns
t _{CHSL}	CS# Not Active Hold Time	5			ns
t _{SHSL}	CS# High Time (Read/Write)	20			ns
t _{SHQZ}	Output Disable Time			6	ns
t _{CLQX}	Output Hold Time	1.0			ns
t _{DVCH}	Data In Setup Time	2			ns
t _{CHDX}	Data In Hold Time	2			ns
t _{HLCH}	HOLD# Low Setup Time (Relative To Clock)	5			ns
t _{HHCH}	HOLD# High Setup Time (Relative To Clock)	5			ns
t _{CHHL}	HOLD# High Hold Time (Relative To Clock)	5			ns
t _{CHHH}	HOLD# Low Hold Time (Relative To Clock)	5			ns
t _{HLQZ}	HOLD# Low To High-Z Output			6	ns
t _{HHQX}	HOLD# Low To Low-Z Output			6	ns
t _{CLQV}	Clock Low To Output Valid			7	ns
t _{WHSL}	Write Protect Setup Time Before CS# Low	20			ns
t _{SHWL}	Write Protect Hold Time After CS# High	100			ns
t _{DP}	CS# High To Deep Power-Down Mode			50	μs
t _{RES1}	CS# High To Standby Mode Without Electronic Signature Read			50	μs
t _{RES2}	CS# High To Standby Mode With Electronic Signature Read			50	μs
t _{SUS}	CS# High To Next Command After Suspend			50	μs
t _{RST}	CS# High To Next Command After Reset (Except From Erase)			50	μs
t _{RST_E}	CS# High To Next Command After Reset (From Erase)			30	ms

t_w	Write Status Register Cycle Time		15	80	ms
t_{BP1}	Byte Program Time (First Byte)		60	150	μ s
t_{BP2}	Additional Byte Program Time (After First Byte)		8	40	μ s
t_{PP}	Page Programming Time		1.6	5	ms
t_{SE}	Sector Erase Time		100	800	ms
t_{BE1}	Block Erase Time (32K Bytes)		0.3	2	s
t_{BE2}	Block Erase Time (64K Bytes)		0.5	3	s
t_{CE}	Chip Erase Time (MD25Q128)		150	400	s

Note:

1. Typical values given for $T_A=25^\circ\text{C}$. Not 100% tested.

Figure36. Serial Input Timing

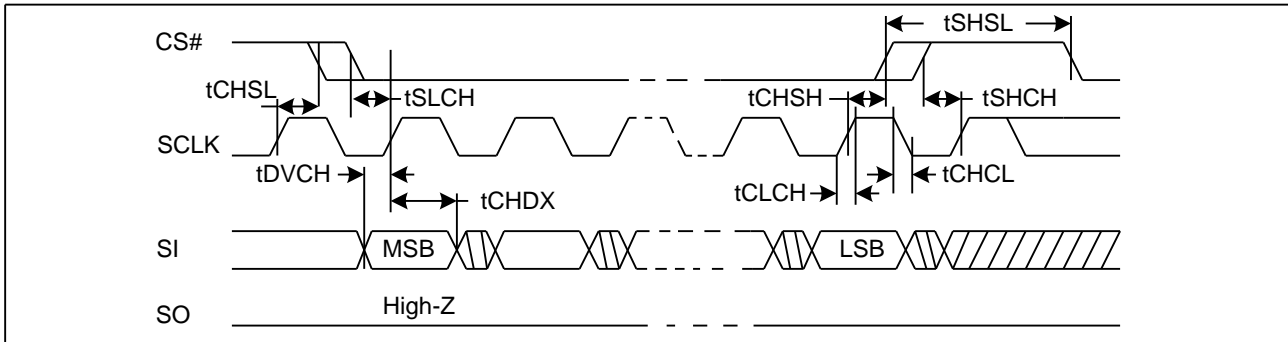

Figure37. Output Timing

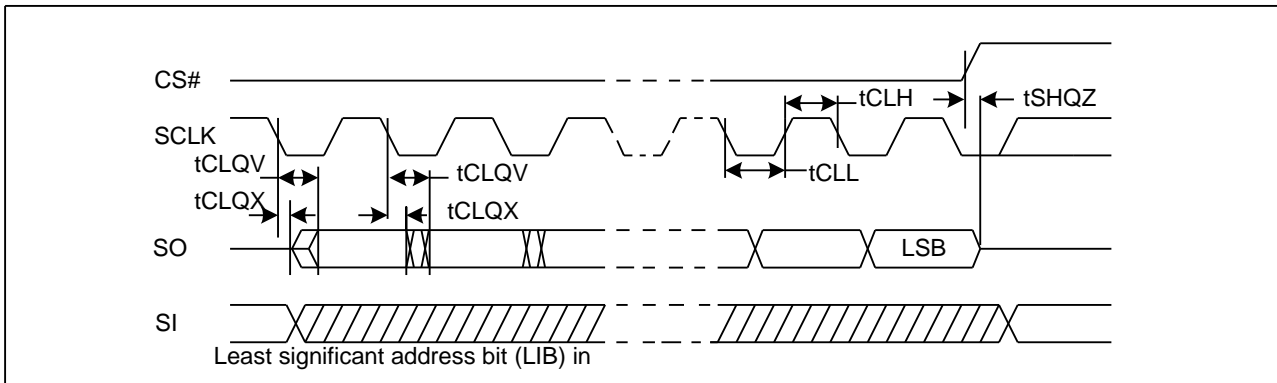

Figure38. Hold Timing

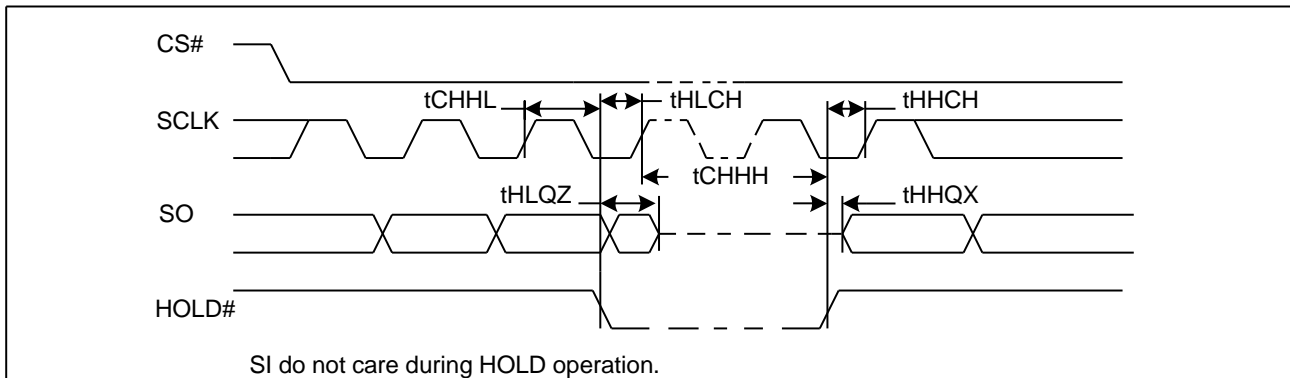

Figure39 RESET Timing

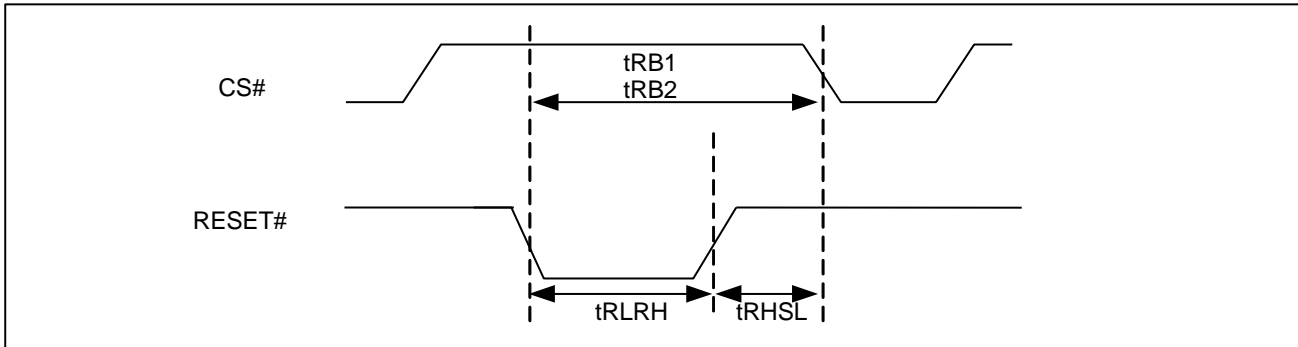

Table 8.2. Reset Timing

Symbol	Parameter	Min.	Typ.	Max.	Unit.
tRLRH	Reset Pulse Width	1			μs
tRHSL	Reset High Time Before Read	50			ns
tRB	Reset Recovery Time			12	ms



9.1. Valid Part Numbers

Please contact GigaDevice regional sales for the latest product selection and available form factors.

Temperature Range I: Industrial (-40°C to +85°C)

Product Number	Density	Package Type
MD25Q128SIG	128Mbit	SOP8 208mil
MD25Q128VIG	128Mbit	VSOP8 208mil
MD25Q128PIG	128Mbit	DIP8 300mil
MD25Q128FIG	128Mbit	SOP16 300mil
MD25Q128FIR		
MD25Q128WIG	128Mbit	WSON8 (6x5mm)
MD25Q128YIG	128Mbit	WSON8 (8x6mm)

10. PACKAGE INFORMATION

10.1. Package SOP8 208MIL

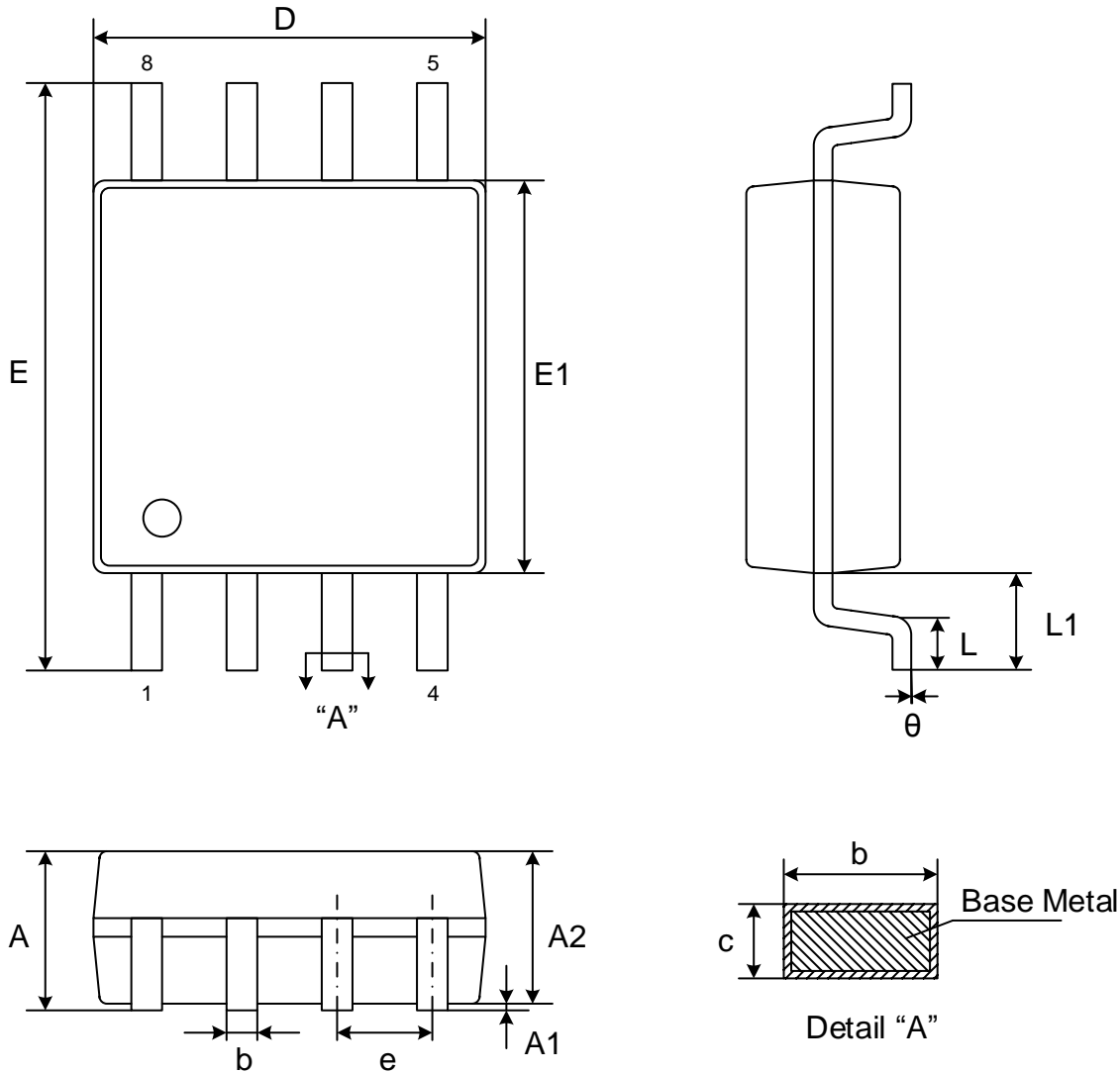

Dimensions

Symbol		A	A1	A2	b	c	D	E	E1	e	L	L1	θ
Unit													
mm	Min	-	0.05	1.70	0.31	0.15	5.13	7.70	5.18	1.27	0.50	1.31	0°
	Nom	-	0.15	1.80	0.41	0.20	5.23	7.90	5.28		-		-
	Max	2.16	0.25	1.90	0.51	0.25	5.33	8.10	5.38		0.85		8°

Note:

- Both the package length and width do not include the mold flash.
- Seating plane: Max. 0.1mm.

10.2. Package VSOP8 208MIL

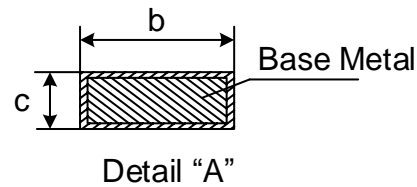
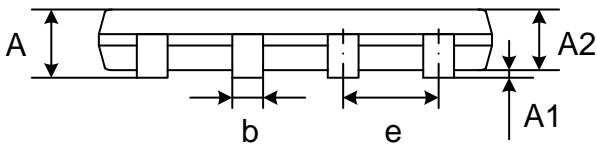
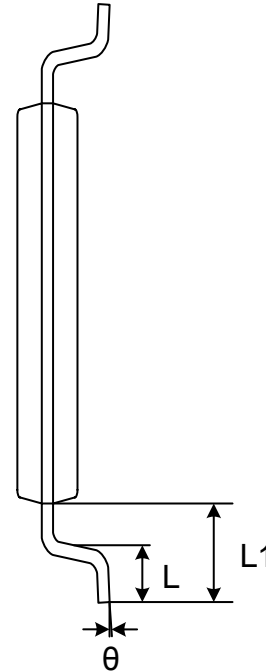
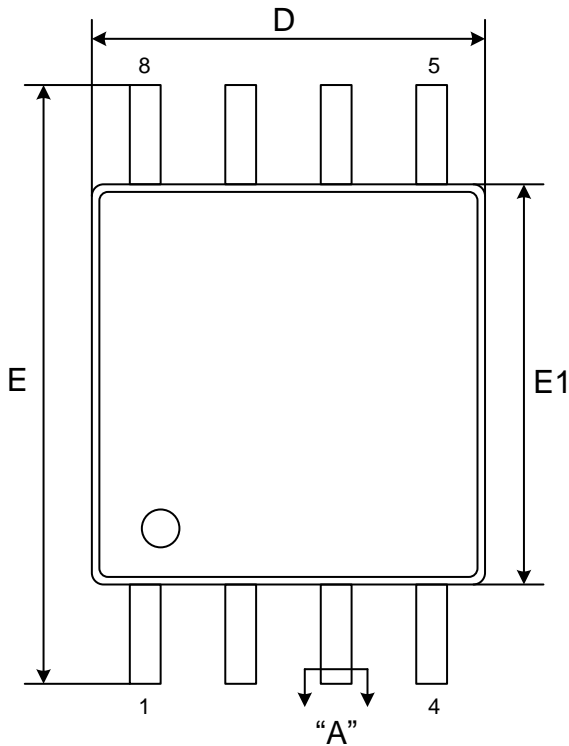

Dimensions

Symbol		A	A1	A2	b	c	D	E	E1	e	L	L1	θ
Unit													
mm	Min	-	0.05	0.75	0.35	0.09	5.18	7.70	5.18	1.27	0.50	1.31	0°
	Nom	-	0.10	0.80	0.42	0.15	5.28	7.90	5.28		-		-
	Max	1.00	0.15	0.85	0.50	0.20	5.38	8.10	5.38		0.80		10°

Note:

- Both the package length and width include the mold flash.
- Seating plane: Max. 0.1mm.

10.3. Package SOP16 300MIL

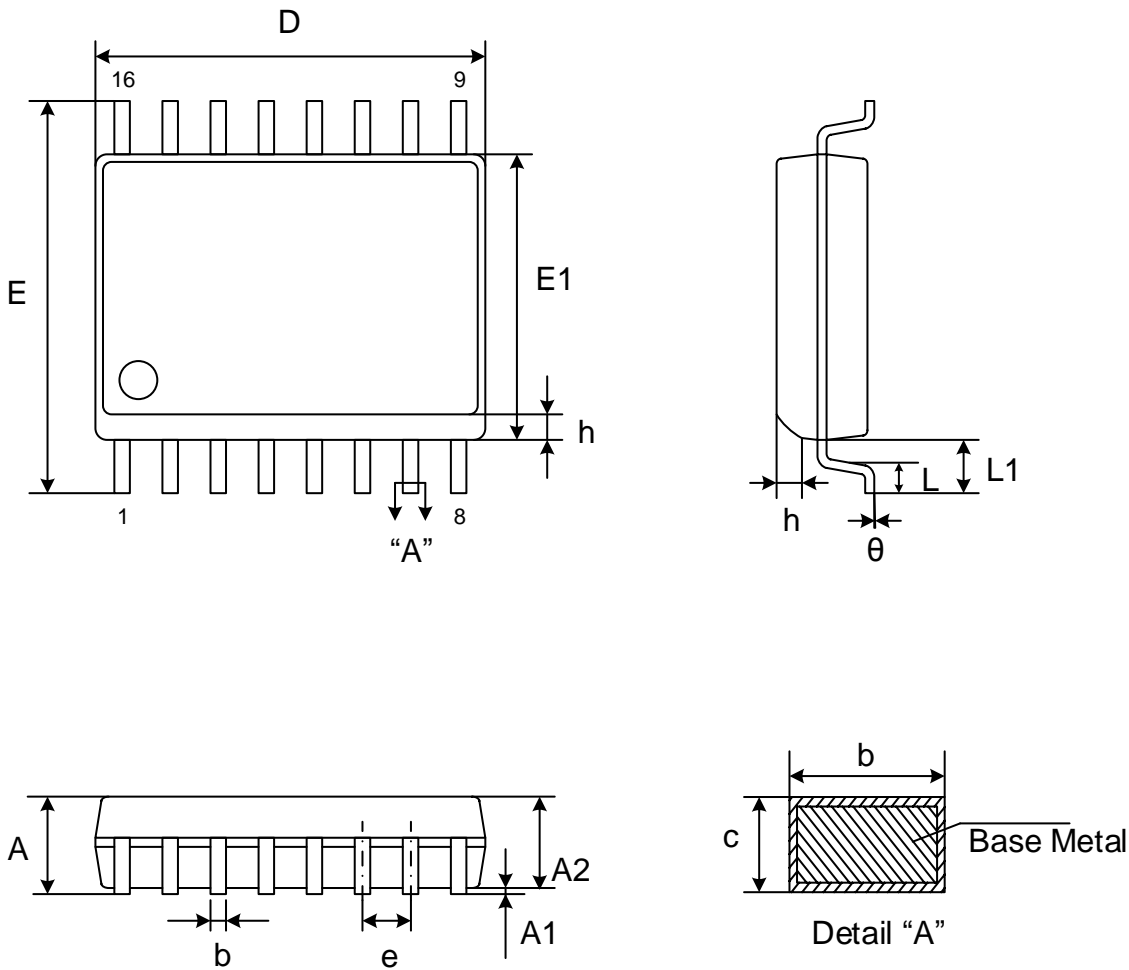

Dimensions

Symbol		A	A1	A2	b	c	D	E	E1	e	L	L1	h	θ	
Unit															
mm	Min	-	0.10	2.05	0.31	0.10	10.20	10.10	7.40	1.27	0.40	1.40	0.25	0	
	Nom	-	0.20	-	0.41	0.25	10.30	10.30	7.50		-		-	-	-
	Max	2.65	0.30	2.55	0.51	0.33	10.40	10.50	7.60		1.27		0.75	8	

Note:

- Both the package length and width do not include the mold flash.
- Seating plane: Max. 0.1mm.

10.4. Package DIP8 300MIL

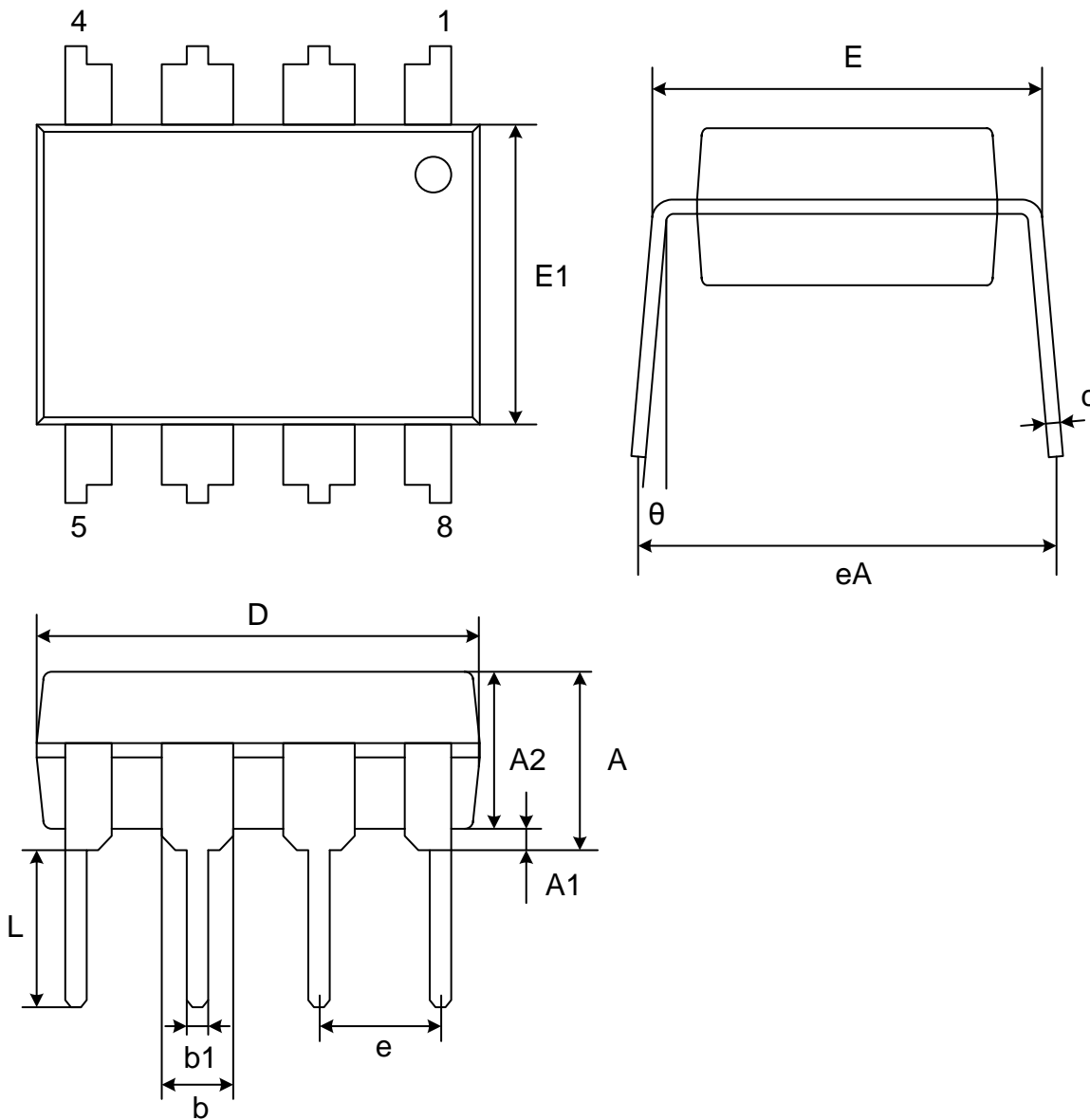

Dimensions

Symbol	A	A1	A2	b	b1	C	D	E	E1	e	L	eA	θ	
Unit														
mm	Min	-	0.38	3.00	1.14	0.36	0.20	9.02	7.62	6.10	2.54	2.92	8.45	0°
	Nom	-	-	3.30	1.52	0.46	0.25	9.27	7.87	6.35		3.30	8.90	-
	Max	3.88	-	3.50	1.78	0.56	0.35	9.59	8.26	6.60		3.81	9.35	11°

Note: Both package length and width do not include mold flash.

10.5. Package WSON8 (6*5mm)

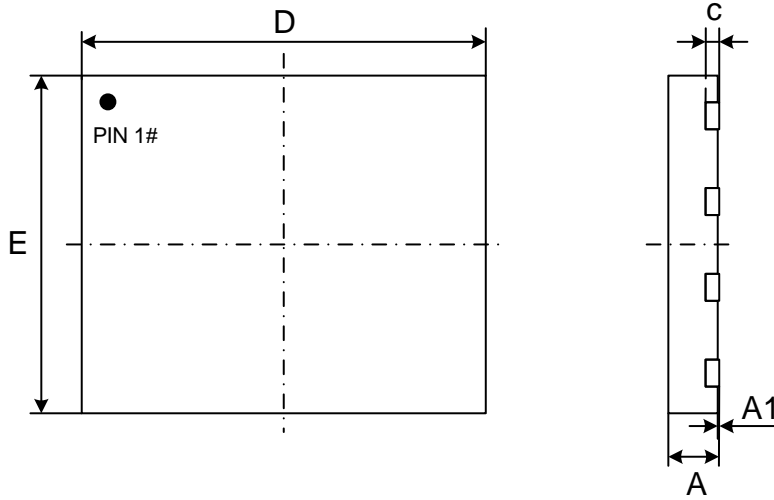

Top View

Side View

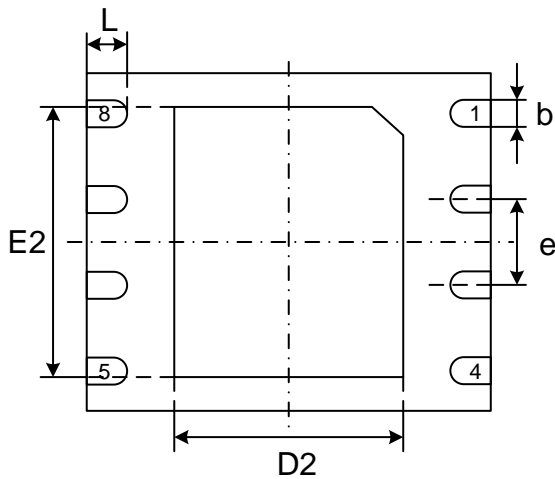

Bottom View

Dimensions

Symbol	A	A1	c	b	D	D2	E	E2	e	L	
Unit											
mm	Min	0.70	0.00	0.180	0.35	5.90	3.30	4.90	3.90	1.27	0.50
	Nom	0.75	0.02	0.203	0.40	6.00	3.40	5.00	4.00		0.60
	Max	0.80	0.05	0.250	0.50	6.10	3.50	5.10	4.10		0.75

Note:

- Both package length and width do not include mold flash.
- The exposed metal pad area on the bottom of the package is floating.

10.6. Package WSON8 (8*6mm)

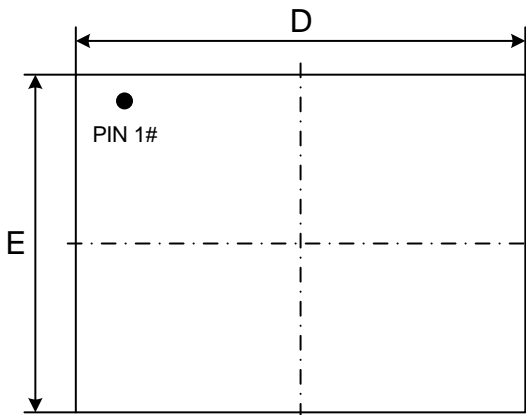

Top View

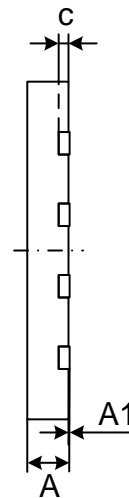

Side View

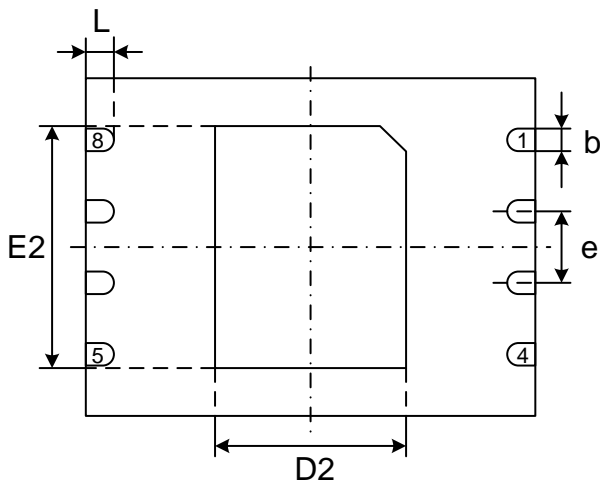

Bottom View

Dimensions

Symbol		A	A1	c	b	D	D2	E	E2	e	L
Unit											
mm	Min	0.70	0.00	0.180	0.35	7.90	3.30	5.90	4.20	1.27	0.45
	Nom	0.75	0.02	0.203	0.40	8.00	3.40	6.00	4.30		0.50
	Max	0.80	0.05	0.250	0.45	8.10	3.50	6.10	4.40		0.55

- Both the package length and width do not include the mold flash.
- The exposed metal pad area on the bottom of the package is floating.
- Coplanarity $\leq 0.08\text{mm}$. Package edge tolerance $\leq 0.10\text{mm}$.
- The lead shape may be of little difference according to different package lead frames. These lead shapes are compatible with each other.

11. REVISION HISTORY

Version No	Description	Page	Date
1.0	Initial Release	---	2013-7-25
1.1	Modify Package WSON 8 (6*5mm) Modify Package WSON 8 (8*6mm) Modify Package TFBGA-24BALL (6*4 ball array)	---	2015-6-12
1.2	Modify Package TFBGA-24BALL (6*4 ball array)	---	2015-7-23
1.3	Modify AC CHARACTERISTICS: tCHCL Min.0.2 V/ns Change to 0.1 V/ns tCLCH Min.0.2 V/ns Change to 0.1 V/ns Modify Figure 40. Power-on Timing Sequence Diagram	---	2015-11-13
1.4	Modify AC CHARACTERISTICS: add trST_R & trST_P & trST_E Modify POWER-ON TIMING: TVSL Min 10us Change to 5ms	---	2015-12-18
1.5	Delete QPI function Modify tPP max value from 2.4ms to 4ms Modify tSE max value from 400ms to 500ms Modify tBE1 max value from 1.0s to 2.0s Modify tBE2 max value from 1.2s to 2.5s Modify tCE max value from 120s to 200s	--- P41 P42 P42 P42 P42	2018-4-19

Important Notice

This document is the property of GigaDevice Semiconductor (Beijing) Inc. and its subsidiaries (the "Company"). This document, including any product of the Company described in this document (the "Product"), is owned by the Company under the intellectual property laws and treaties of the People's Republic of China and other jurisdictions worldwide. The Company reserves all rights under such laws and treaties and does not grant any license under its patents, copyrights, trademarks, or other intellectual property rights. The names and brands of third party referred thereto (if any) are the property of their respective owner and referred to for identification purposes only.

The Company makes no warranty of any kind, express or implied, with regard to this document or any Product, including, but not limited to, the implied warranties of merchantability and fitness for a particular purpose. The Company does not assume any liability arising out of the application or use of any Product described in this document. Any information provided in this document is provided only for reference purposes. It is the responsibility of the user of this document to properly design, program, and test the functionality and safety of any application made of this information and any resulting product. Except for customized products which has been expressly identified in the applicable agreement, the Products are designed, developed, and/or manufactured for ordinary business, industrial, personal, and/or household applications only. The Products are not designed, intended, or authorized for use as components in systems designed or intended for the operation of weapons, weapons systems, nuclear installations, atomic energy control instruments, combustion control instruments, airplane or spaceship instruments, transportation instruments, traffic signal instruments, life-support devices or systems, other medical devices or systems (including resuscitation equipment and surgical implants), pollution control or hazardous substances management, or other uses where the failure of the device or Product could cause personal injury, death, property or environmental damage ("Unintended Uses"). Customers shall take any and all actions to ensure using and selling the Products in accordance with the applicable laws and regulations. The Company is not liable, in whole or in part, and customers shall and hereby do release the Company as well as it's suppliers and/or distributors from any claim, damage, or other liability arising from or related to all Unintended Uses of the Products. Customers shall indemnify and hold the Company as well as it's suppliers and/or distributors harmless from and against all claims, costs, damages, and other liabilities, including claims for personal injury or death, arising from or related to any Unintended Uses of the Products.

Information in this document is provided solely in connection with the Products. The Company reserves the right to make changes, corrections, modifications or improvements to this document and the Products and services described herein at any time, without notice.

单击下面可查看定价，库存，交付和生命周期等信息

[>>GigaDevice\(兆易创新\)](#)