

**GigaDevice Semiconductor Inc.**

**GD32105C-EVAL Evaluation Board**

**User Manual**

## Table of Contents

<b>List of Figures .....</b>	<b>2</b>
<b>1 Introduction .....</b>	<b>3</b>
<b>2 Function pin assignment .....</b>	<b>3</b>
<b>3 Getting started .....</b>	<b>4</b>
<b>4 Hardware layout overview .....</b>	<b>5</b>
4.1 Power supply .....	5
4.2 Boot option .....	5
4.3 LED .....	6
4.4 Key .....	6
4.5 USART1/USART2 .....	7
4.6 ADC/DAC .....	7
4.7 I2S .....	8
4.8 I2C .....	8
4.9 SPI-Serial Flash .....	9
4.10 USB .....	9
4.11 CAN .....	10
4.12 RTC .....	10
4.13 EXMC-LCD .....	11
4.14 EXMC-NAND Flash .....	12
4.15 Extension .....	12
<b>5 Revision history .....</b>	<b>13</b>

## List of Figures

Figure 1 Schematic diagram of power supply .....	5
Figure 2. Schematic diagram of boot option.....	5
Figure 3. Schematic diagram of LED function.....	6
Figure 4. Schematic diagram of Key function.....	6
Figure 5. Schematic diagram of USART1/USART2 function .....	7
Figure 6. Schematic diagram of ADC/DAC function .....	7
Figure 7. Schematic diagram of I2S function.....	8
Figure 8. Schematic diagram of I2C function .....	8
Figure 9. Schematic diagram of SPI-Serial Flash function.....	9
Figure 10.Schematic diagram of USB function .....	9
Figure 11. Schematic diagram of CAN function .....	10
Figure 12. Schematic diagram of RTC function .....	10
Figure 13. Schematic diagram of EXMC-LCD function.....	11
Figure 14. Schematic diagram of EXMC-NAND Flash function .....	12
Figure 15. Schematic diagram of Extension Pin.....	12

# 1 Introduction

GD32105C-EVAL evaluation board uses GD32F105VCT6 as the main controller. As a complete development platform of GD32F105xx connectivity line powered by ARM® Cortex™-M3 core, the board supports full range of peripherals. It uses Mini USB interface or AC/DC adapter as 5V power supply. JTAG, Reset, Boot, User button key, LED, CAN, I2C, I2S, USART, RTC, EXMC, SPI, USB\_OTG, ADC, DAC and Extension Pin are also included. This document details its hardware schematic and the relevant applications.

# 2 Function pin assignment

**Table 1. Pin assignment**

Function	Pin	Description
LED	PC0	LED2
	PC2	LED3
	PE0	LED4
	PE1	LED5
RESET		K1-Reset
KEY	PA0	KEY1
	PC13	KEY2
	PB14	KEY3
USB_OTG	PA9	USB_VBUS
	PA10	USB_ID
	PA11	USBDM
	PA12	USBDP
	PD13	VBUS control pin
CAN	PD0	CAN1_RX
	PD1	CAN1_TX
	PB5	CAN2_RX
	PB6	CAN2_TX
I2C	PB6	I2C1_SCL
	PB7	I2C_SDA
I2S	PB12	I2S_WS
	PB13	I2S_CK
	PB15	I2S_DIN
	PA4	MSEL
	PA5	MCLK
	PA7	MDIN
	PC6	I2S_MCK
USART1	PA9	USART1_TX
	PA10	USART1_RX
USART2	PA2	USART2_TX

Function	Pin	Description
	PA3	USART2_RX
EXMC	PD14	EXMC_D0
	PD15	EXMC_D1
	PD0	EXMC_D2
	PD1	EXMC_D3
	PE7	EXMC_D4
	PE8	EXMC_D5
	PE9	EXMC_D6
	PE10	EXMC_D7
	PE11	EXMC_D8
	PE12	EXMC_D9
	PE13	EXMC_D10
	PE14	EXMC_D11
	PE15	EXMC_D12
	PD8	EXMC_D13
	PD9	EXMC_D14
	PD10	EXMC_D15
	PD11	EXMC_A16
	PD12	EXMC_A17
	PE2	EXMC_A23
	PD4	EXMC_NOE
PD5	EXMC_NWE	
PD6	EXMC_NWAIT	
PD7	EXMC_NE1	
SPI	PA5	SPI1_SCK
	PA6	SPI1_MISO
	PA7	SPI1_MOSI
	PE3	SPI Flash_CS
ADC	PC3	ADC123_IN13
DAC	PA4	DAC_OUT1
	PA5	DAC_OUT2

### 3 Getting started

The EVAL Board uses Mini USB connector to get power, the hardware system power is +3.3V. A Mini USB cable and a J-Link tool are necessary to down programs. Select the correct boot mode and then power on, the LED1 will turn on, which indicates the power supply is ready.

## 4 Hardware layout overview

### 4.1 Power supply

Figure 1 Schematic diagram of power supply

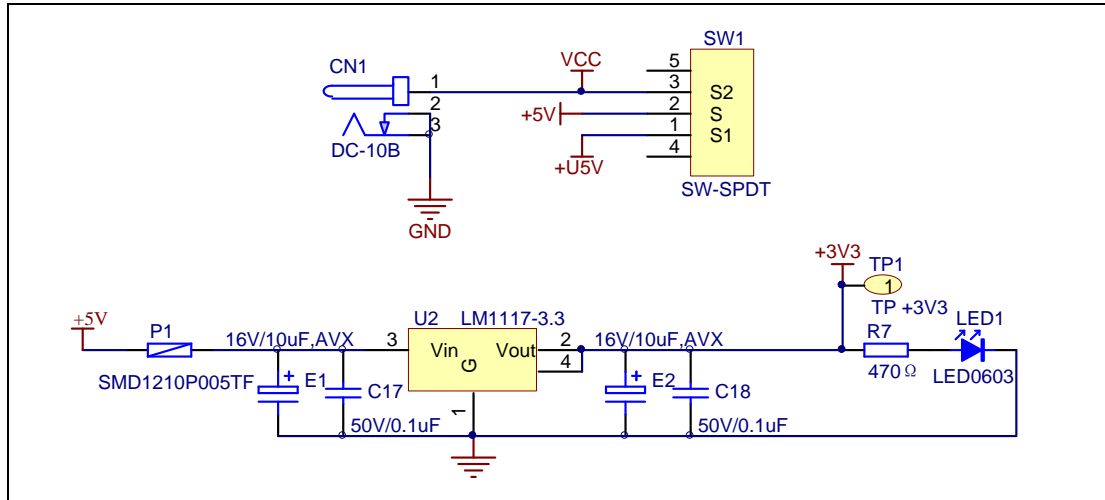

### 4.2 Boot option

Figure 2. Schematic diagram of boot option

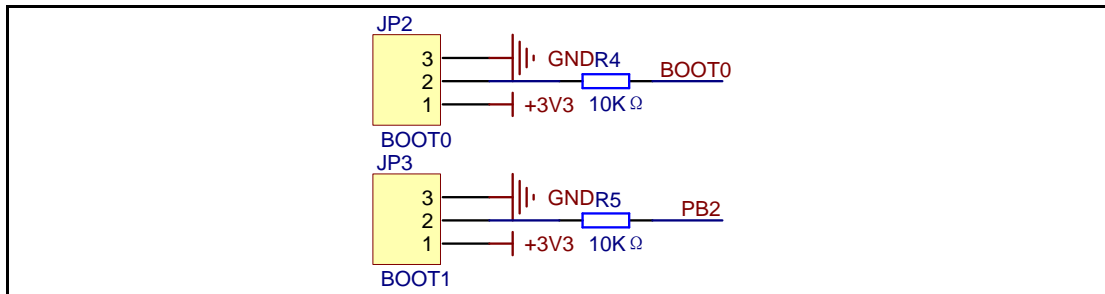
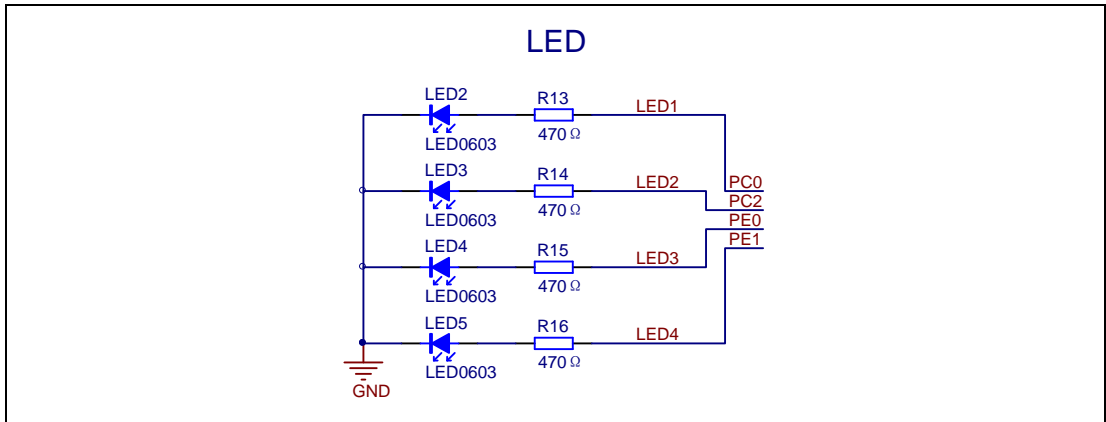

Table 2. Boot configuration

BOOT1	BOOT0	Boot Mode
Any	2-3	User memory
2-3	1-2	System memory
1-2	1-2	SRAM memory

### 4.3 LED

Figure 3. Schematic diagram of LED function



### 4.4 Key

Figure 4. Schematic diagram of Key function

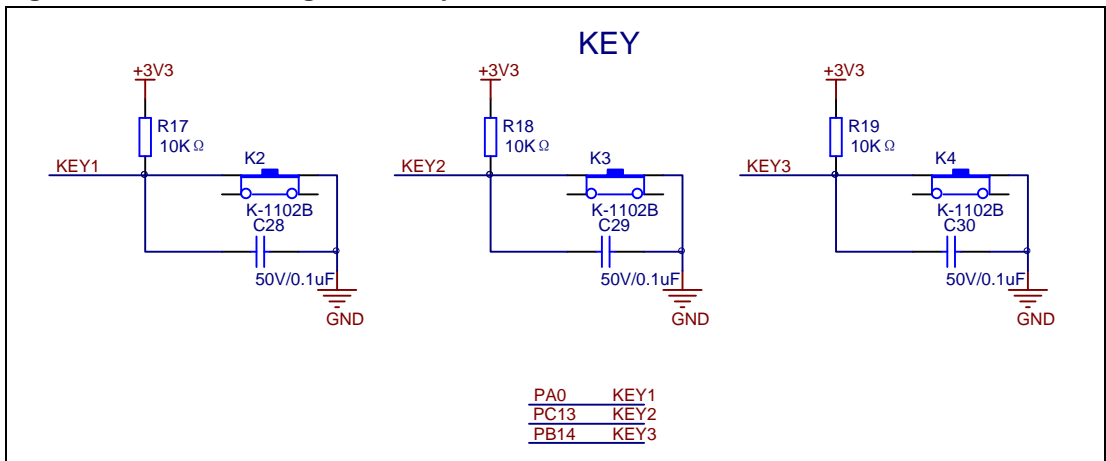

## 4.5 USART1/USART2

Figure 5. Schematic diagram of USART1/USART2 function

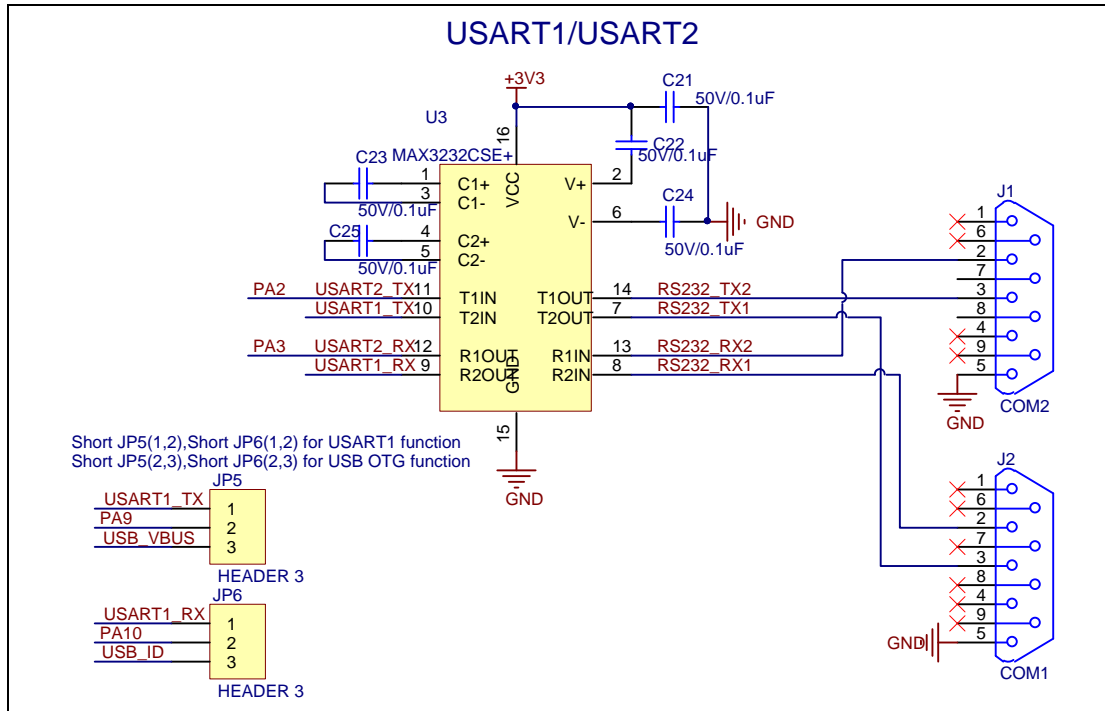

## 4.6 ADC/DAC

Figure 6. Schematic diagram of ADC/DAC function

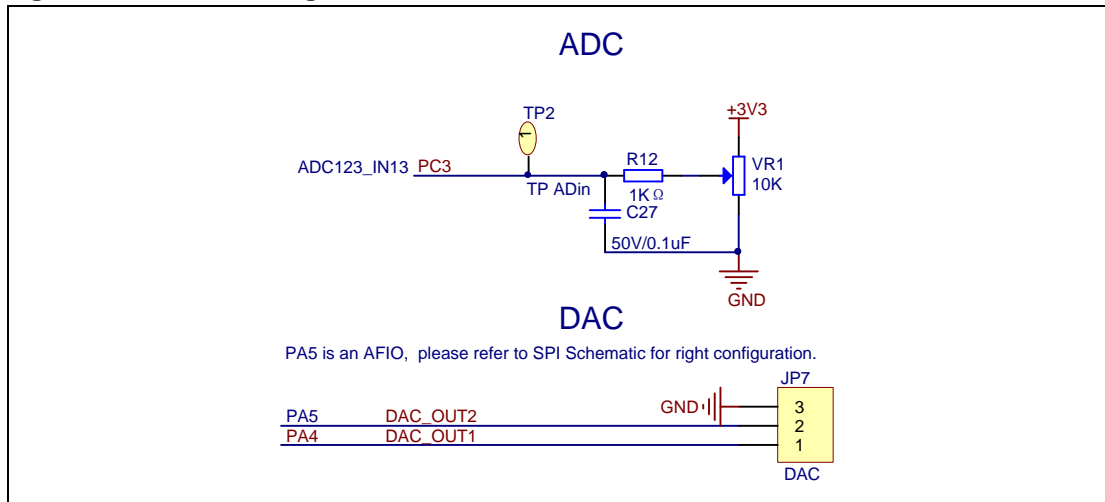



## 4.7 I2S

Figure 7. Schematic diagram of I2S function

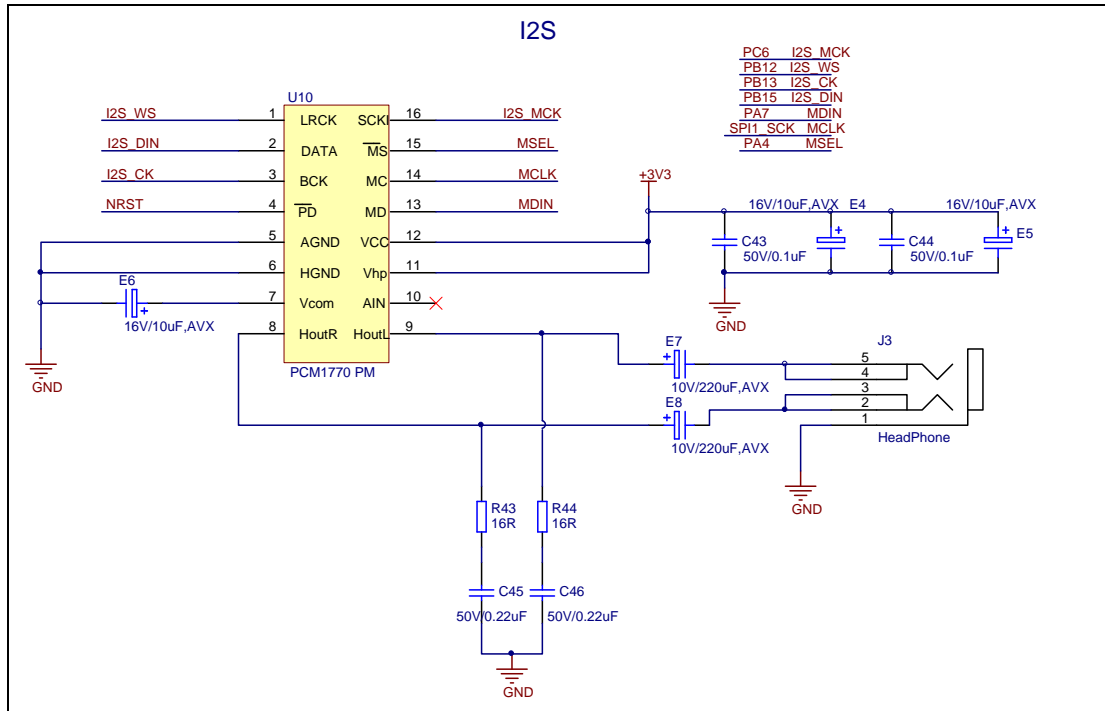

## 4.8 I2C

Figure 8. Schematic diagram of I2C function

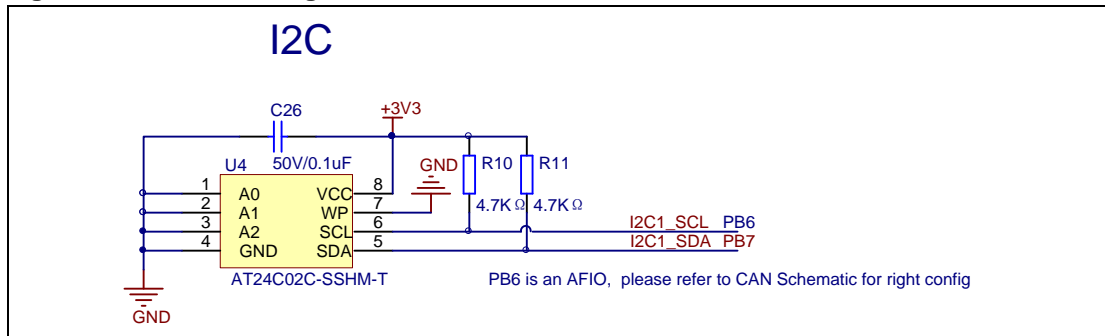

## 4.9 SPI-Serial Flash

Figure 9. Schematic diagram of SPI-Serial Flash function

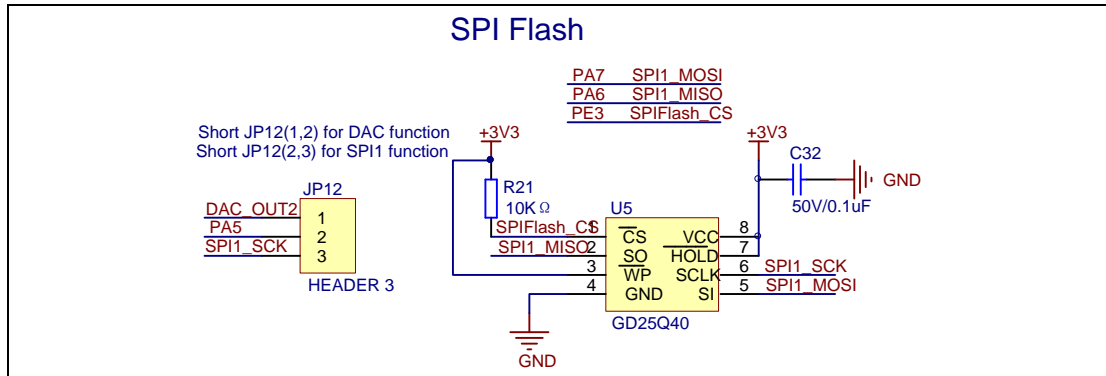

## 4.10 USB

Figure 10. Schematic diagram of USB function

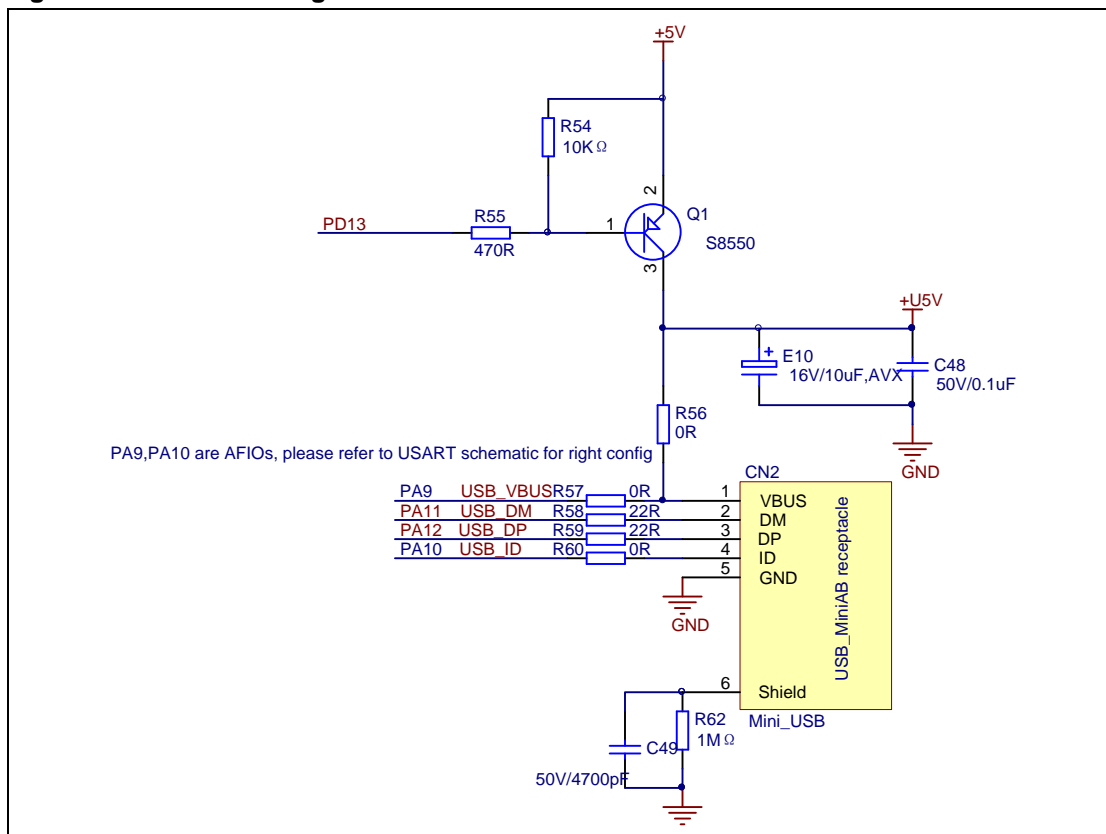

## 4.11 CAN

Figure 11. Schematic diagram of CAN function

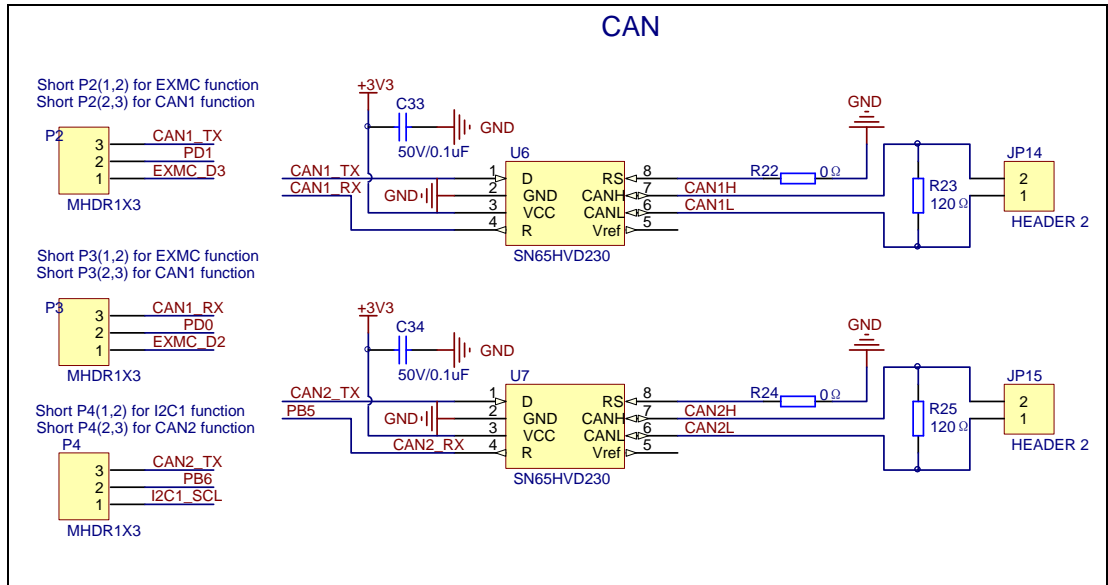

## 4.12 RTC

Figure 12. Schematic diagram of RTC function

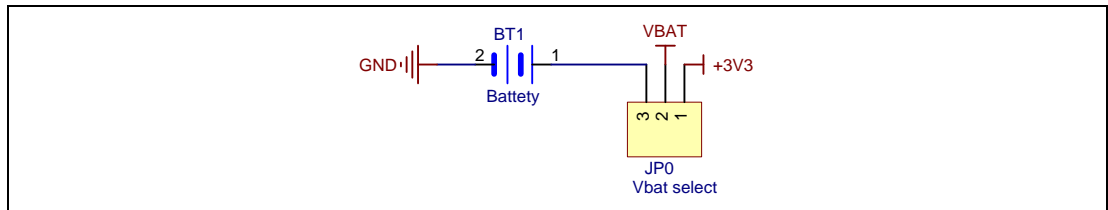

## 4.13 EXMC-LCD

The EVAL Board supports EXMC function and uses a short jumper to extend EXMC\_NE1. But only one extended NE1 (LCD\_CS, Nand\_CS) can be used at any time.

**Figure 13. Schematic diagram of EXMC-LCD function**

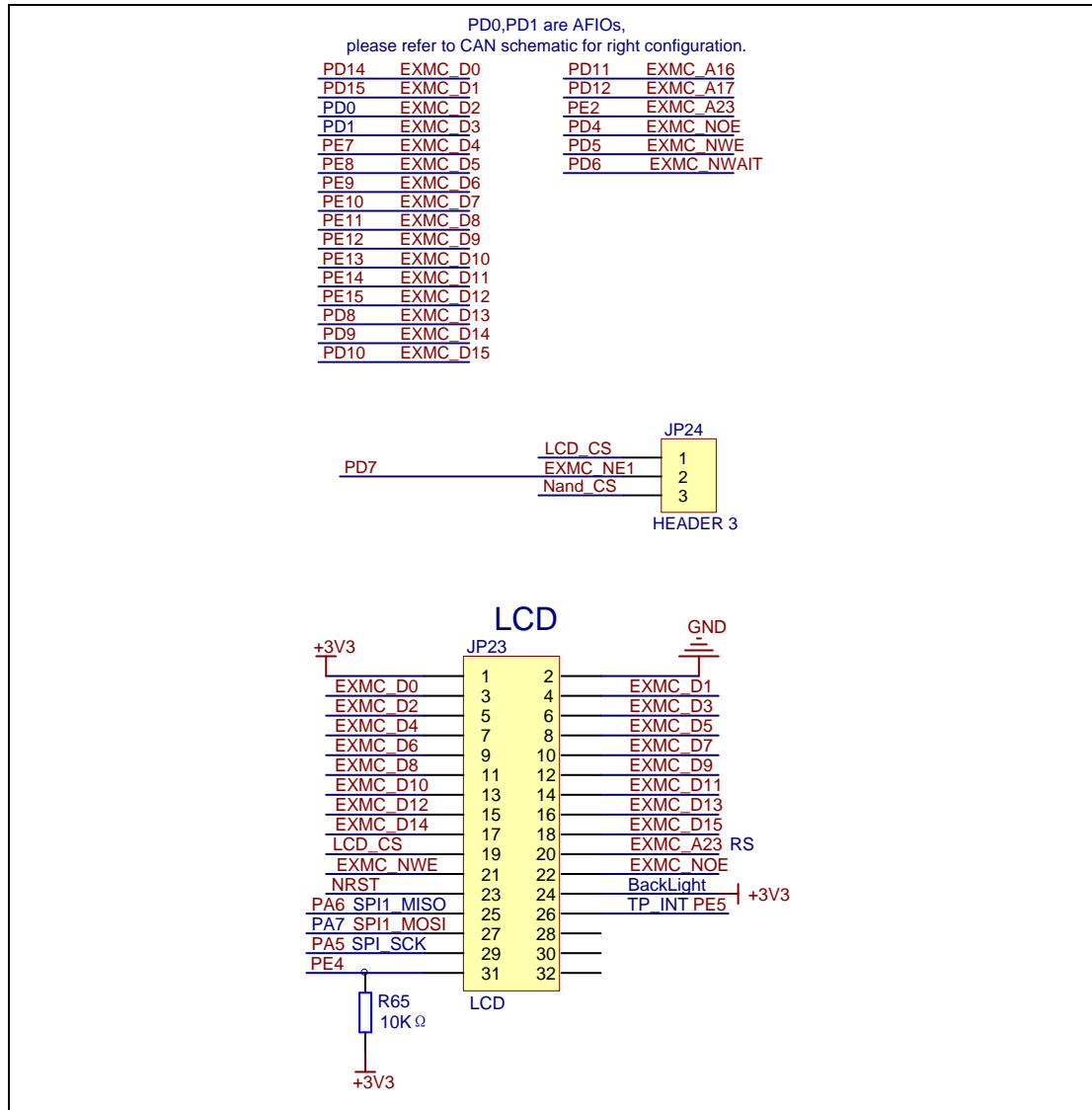

## 4.14 EXMC-NAND Flash

Figure 14. Schematic diagram of EXMC-NAND Flash function

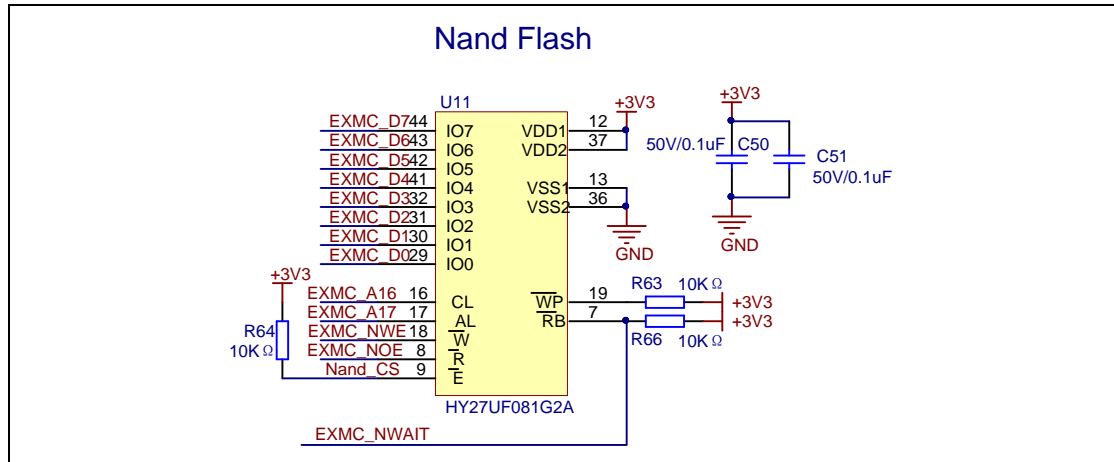

## 4.15 Extension

Figure 15. Schematic diagram of Extension Pin

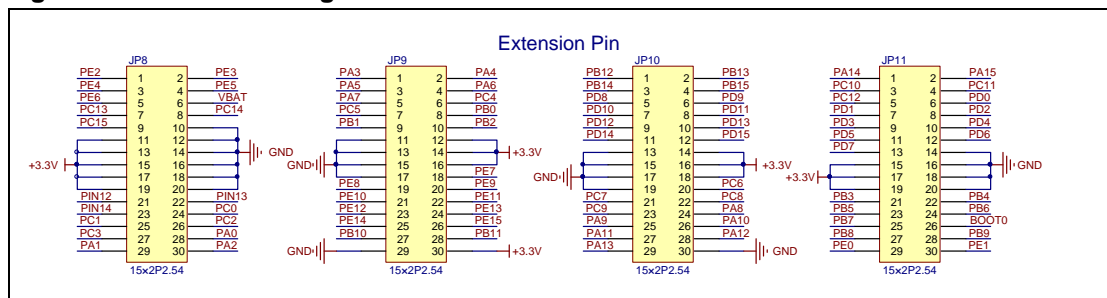

## 5 Revision history

Table 3. Revision history

Revision No.	Description	Date
1.0	Initial Release	Nov.9, 2013

单击下面可查看定价，库存，交付和生命周期等信息

[>>GigaDevice\(兆易创新\)](#)