

GigaDevice Semiconductor Inc.

GD32103E-EVAL Evaluation Board

User Manual

Table of Contents

List of Figures	2
1 Introduction	3
2 Function pin assignment	3
3 Getting started	5
4 Hardware layout overview	5
4.1 Power supply	5
4.2 Boot option	5
4.3 LED	6
4.4 Key	6
4.5 USART1/USART2	7
4.6 ADC/DAC	7
4.7 I2S	8
4.8 I2C	8
4.9 SPI-Serial Flash	9
4.10 SDIO	9
4.11 USB	10
4.12 CAN	10
4.13 RTC	10
4.14 EXMC-LCD	11
4.15 EXMC-NAND Flash	12
4.16 Extension	12
5 Revision history	13

List of Figures

Figure 1 Schematic diagram of power supply	5
Figure 2. Schematic diagram of boot option.....	5
Figure 3. Schematic diagram of LED function.....	6
Figure 4. Schematic diagram of Key function.....	6
Figure 5. Schematic diagram of USART1/USART2 function	7
Figure 6. Schematic diagram of ADC/DAC function	7
Figure 7. Schematic diagram of I2S function.....	8
Figure 8. Schematic diagram of I2C function	8
Figure 9. Schematic diagram of SPI-Serial Flash function.....	9
Figure 10. Schematic diagram of SDIO function.....	9
Figure 11. Schematic diagram of USB function	10
Figure 12. Schematic diagram of CAN function	10
Figure 13. Schematic diagram of RTC function	10
Figure 14. Schematic diagram of EXMC-LCD function.....	11
Figure 15. Schematic diagram of EXMC-NAND Flash function	12
Figure 16. Schematic diagram of Extension Pin	12

1 Introduction

GD32103E-EVAL evaluation board uses GD32F103ZET6 as the main controller. As a complete development platform of GD32F103xx powered by ARM® Cortex™-M3 core, the board supports full range of peripherals. It uses Mini USB interface or AC/DC adapter as 5V power supply. JTAG, Reset, Boot, User button key, LED, CAN, I2C, I2S, USART, SDIO, RTC, EXMC, SPI, USB, ADC, DAC and Extension Pin are also included. This document details its hardware schematic and the relevant applications.

2 Function pin assignment

Table 1. Pin assignment

Function	Pin	Description
LED	PF0	LED2
	PF1	LED3
	PF2	LED4
	PF3	LED5
RESET		K1-Reset
KEY	PA0	K2-Wakeup
	PC13	K3-Temper
	PF5	K4-User Key1
	PF4	K5-User Key2
USB	PA11	USBDM
	PA12	USBDP
	PG8	USBDP pull up pin
CAN	PD0	CAN_RX
	PD1	CAN_TX
I2C	PB6	I2C1_SCL
	PB7	I2C1_SDA
I2S	PB12	I2S2_WS
	PB13	I2S2_CK
	PB15	I2S2_DIN
	PA4	MSEL
	PA5	MCLK
	PA7	MDIN
	PC6	I2S2_MCK
USART1	PA9	USART1_TX
	PA10	USART1_RX
USART2	PA2	USART2_TX
	PA3	USART2_RX
SDIO	PC8	SDIO_DAT0
	PC9	SDIO_DAT1

Function	Pin	Description
	PC10	SDIO_DAT2
	PC11	SDIO_DAT3
	PB8	SDIO_DAT4
	PB9	SDIO_DAT5
	PC6	SDIO_DAT6
	PC7	SDIO_DAT7
	PD2	SDIO_CMD
	PC12	SDIO_CLK
EXMC	PD14	EXMC_D0
	PD15	EXMC_D1
	PD0	EXMC_D2
	PD1	EXMC_D3
	PE7	EXMC_D4
	PE8	EXMC_D5
	PE9	EXMC_D6
	PE10	EXMC_D7
	PE11	EXMC_D8
	PE12	EXMC_D9
	PE13	EXMC_D10
	PE14	EXMC_D11
	PE15	EXMC_D12
	PD8	EXMC_D13
	PD9	EXMC_D14
	PD10	EXMC_D15
	PD11	EXMC_A16
	PD12	EXMC_A17
	PE2	EXMC_A23
	PD4	EXMC_NOE
PD5	EXMC_NWE	
PD6	EXMC_NWAIT	
PD7	EXMC_NCE2	
PG6	EXMC_INT2	
PG9	EXMC_NE2	
SPI	PA5	SPI1_SCK
	PA6	SPI1_MISO
	PA7	SPI1_MOSI
	PE3	SPI Flash_CS
ADC	PC3	ADC123c_IN13
DAC	PA4	DAC_OUT1
	PA5	DAC_OUT2

3 Getting started

The EVAL Board uses Mini USB connector to get power, the hardware system power is +3.3V. A Mini USB cable and a J-Link tool are necessary to down programs. Select the correct boot mode and then power on, the LED1 will turn on, which indicates the power supply is ready.

4 Hardware layout overview

4.1 Power supply

Figure 1 Schematic diagram of power supply

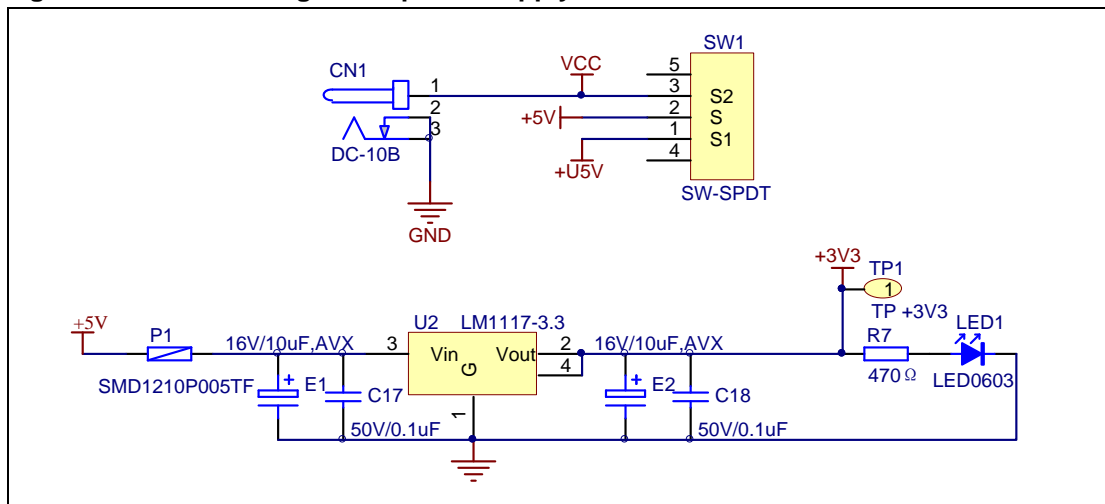

4.2 Boot option

Figure 2. Schematic diagram of boot option

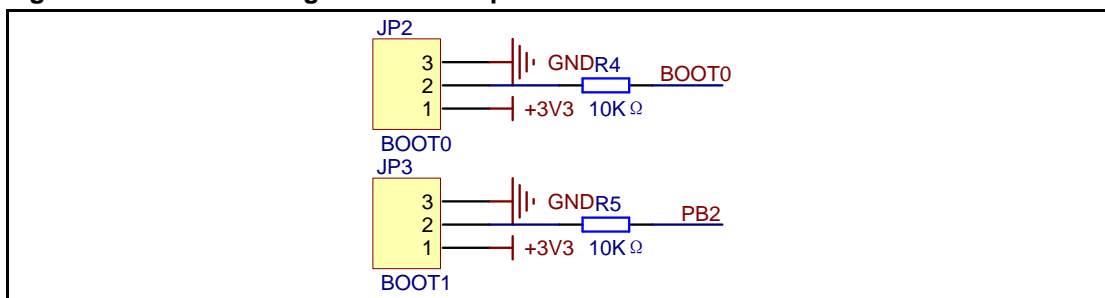
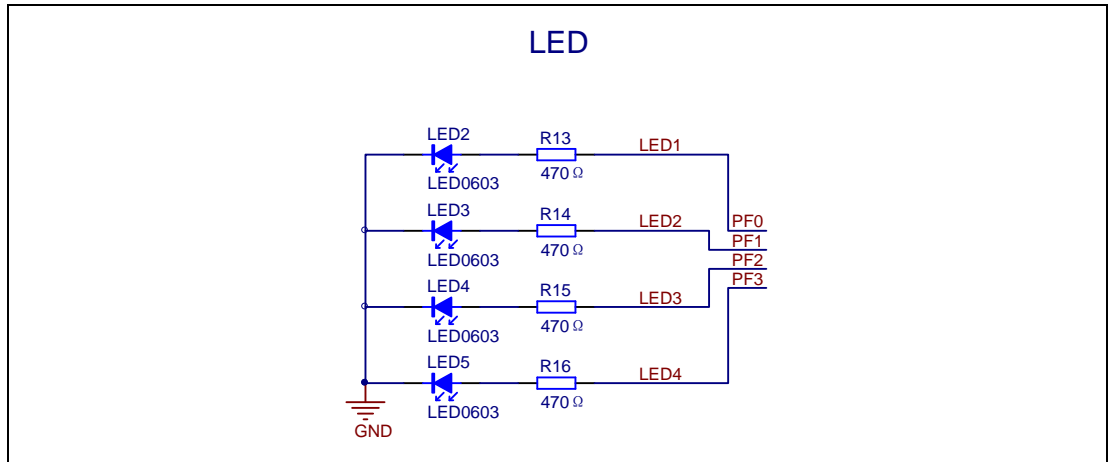

Table 2. Boot configuration

BOOT1	BOOT0	Boot Mode
Any	2-3	User memory
2-3	1-2	System memory
1-2	1-2	SRAM memory

4.3 LED

Figure 3. Schematic diagram of LED function



4.4 Key

Figure 4. Schematic diagram of Key function

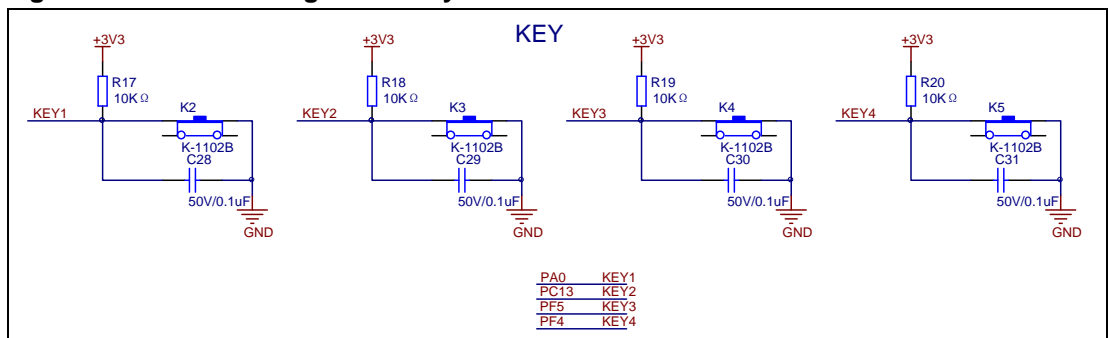

4.5 USART1/USART2

Figure 5. Schematic diagram of USART1/USART2 function

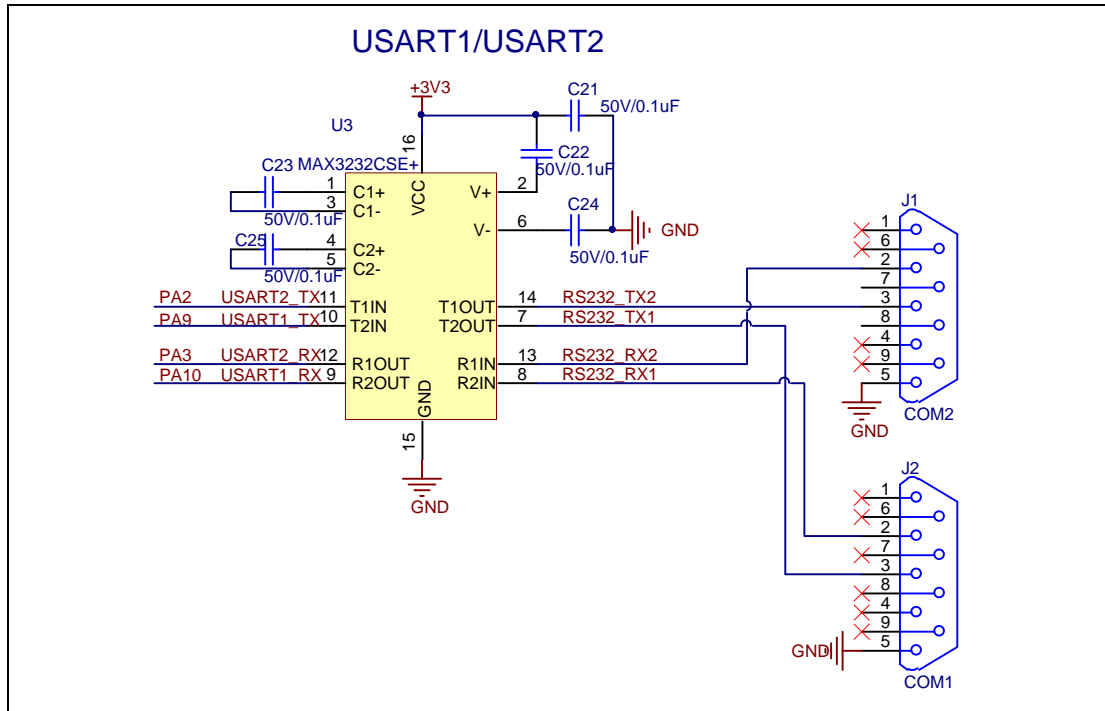

4.6 ADC/DAC

Figure 6. Schematic diagram of ADC/DAC function

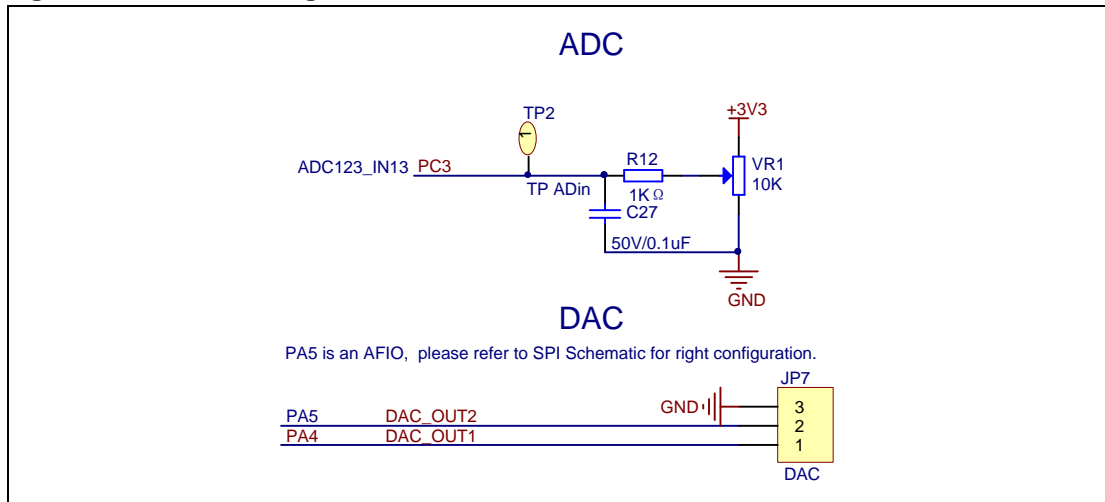

4.7 I2S

Figure 7. Schematic diagram of I2S function

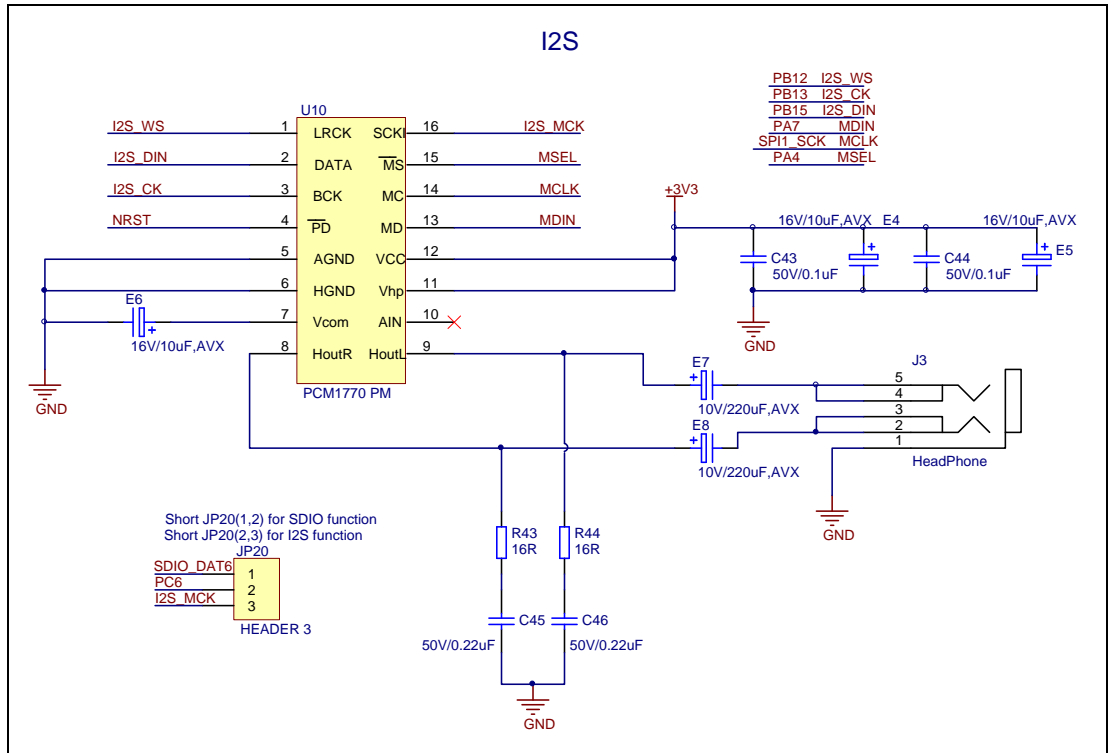

4.8 I2C

Figure 8. Schematic diagram of I2C function

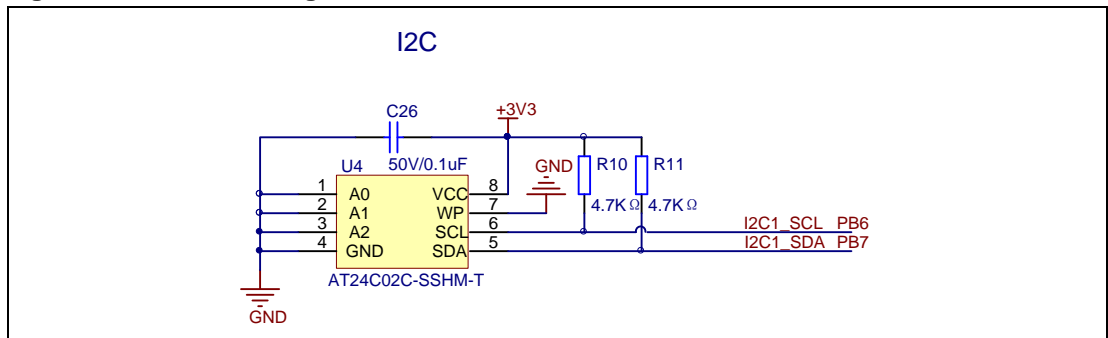

4.9 SPI-Serial Flash

Figure 9. Schematic diagram of SPI-Serial Flash function

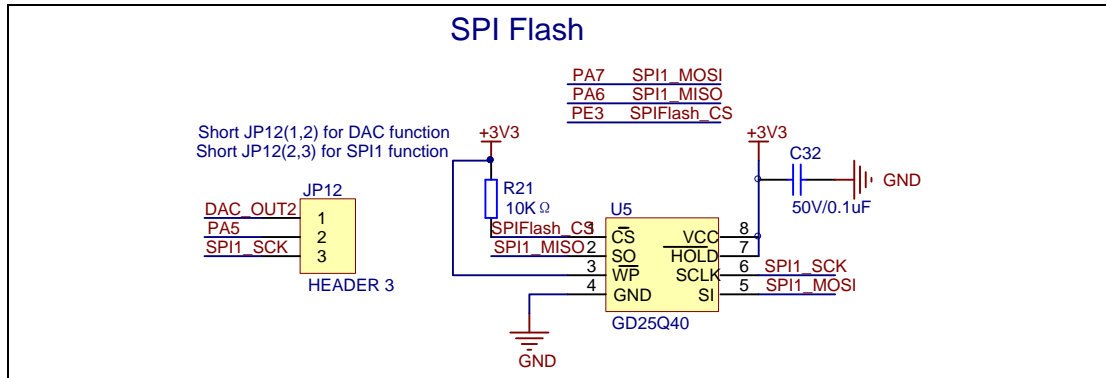

4.10 SDIO

Figure 10. Schematic diagram of SDIO function

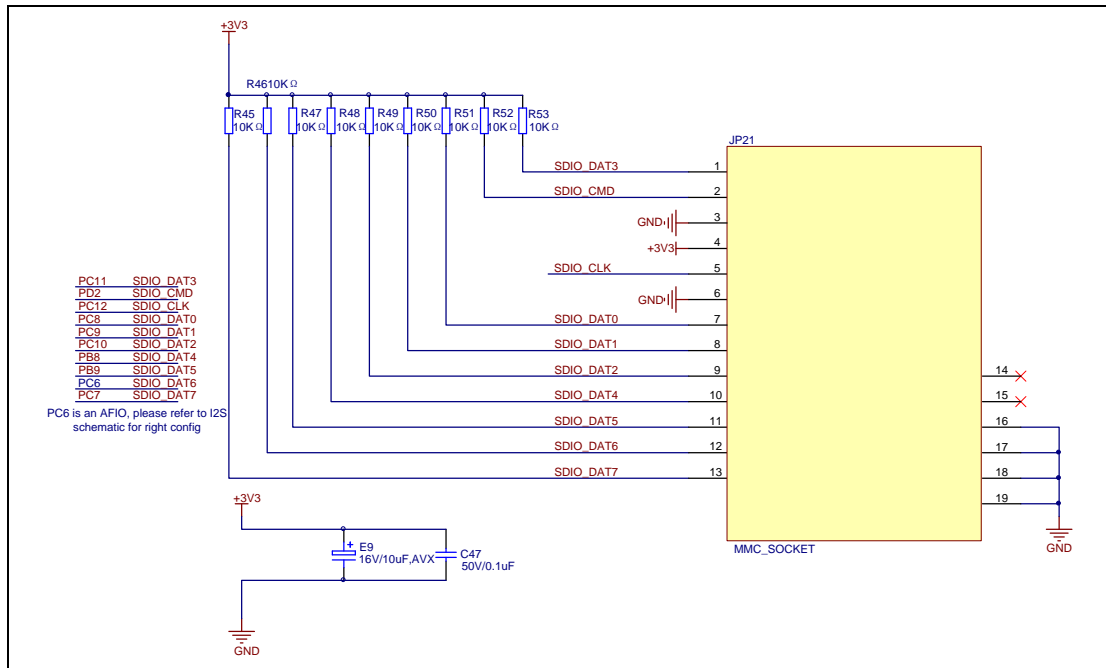

4.11 USB

Figure 11. Schematic diagram of USB function

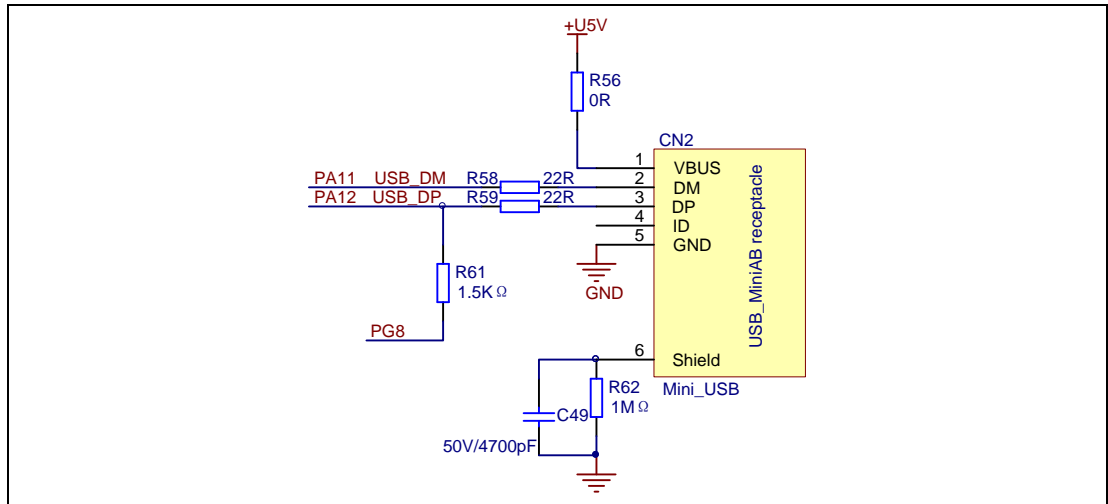

4.12 CAN

Figure 12. Schematic diagram of CAN function

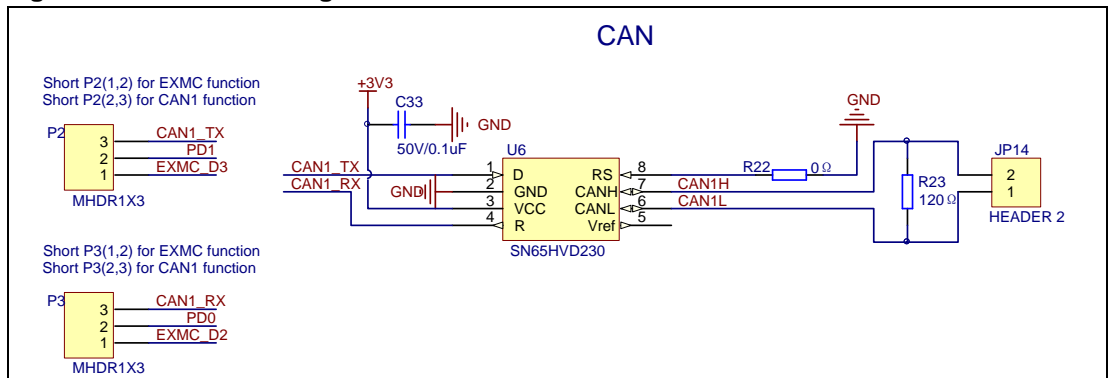

4.13 RTC

Figure 13. Schematic diagram of RTC function

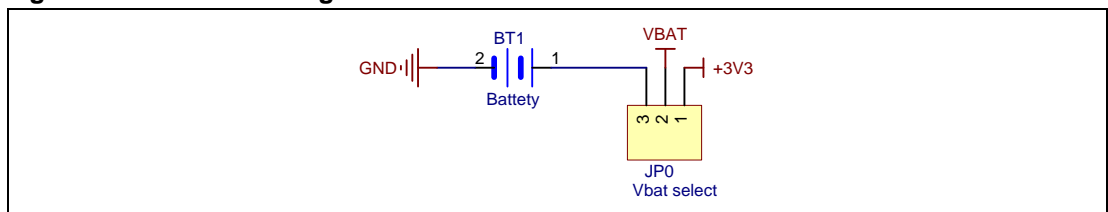

4.14 EXMC-LCD

The EVAL Board supports EXMC function and uses PD7 and PG9 as the extern memory select pin.

Figure 14. Schematic diagram of EXMC-LCD function

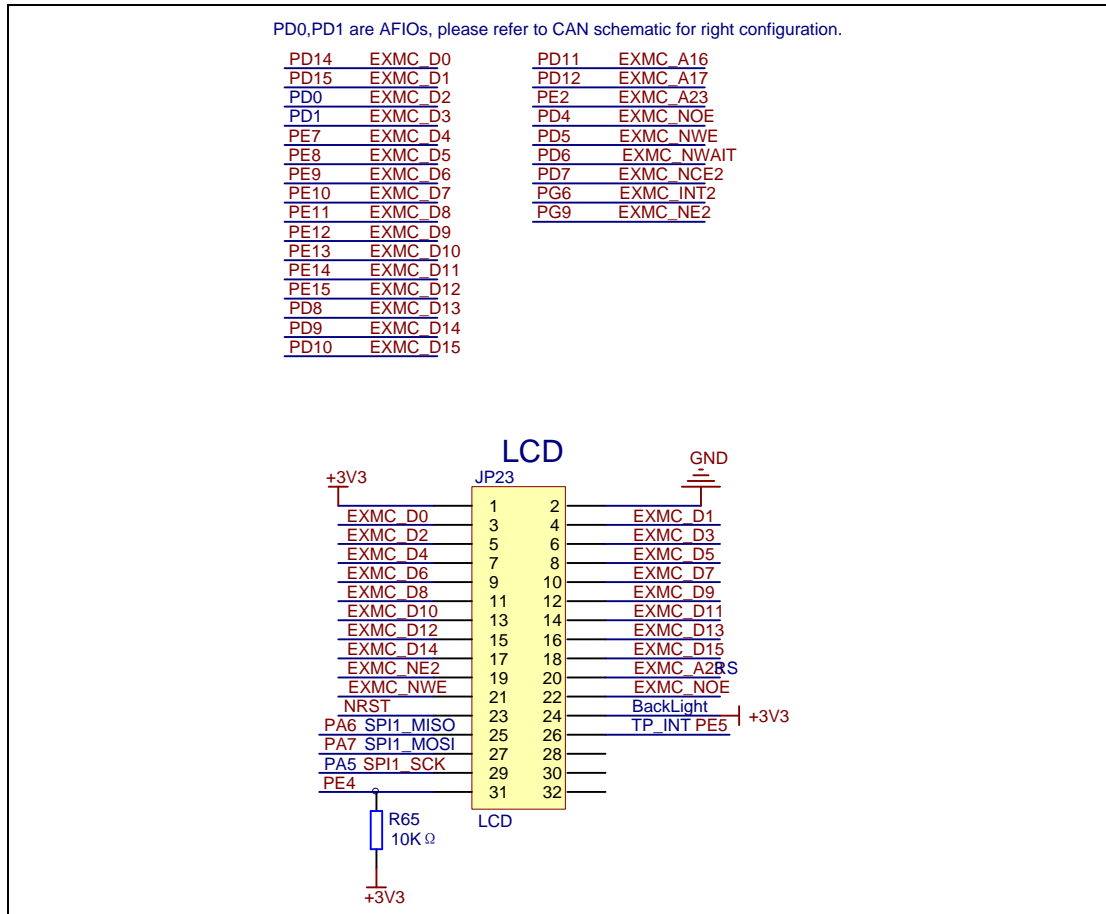

4.15 EXMC-NAND Flash

Figure 15. Schematic diagram of EXMC-NAND Flash function

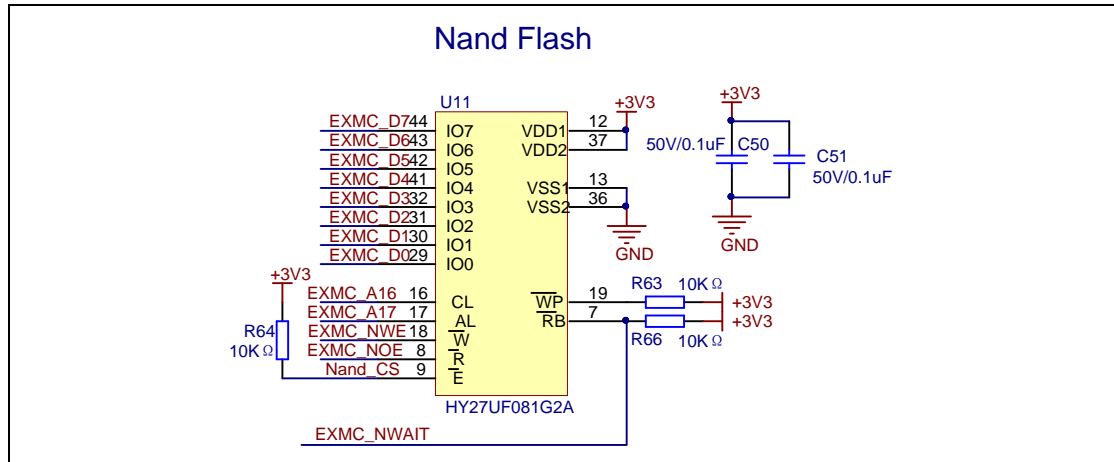

4.16 Extension

Figure 16. Schematic diagram of Extension Pin

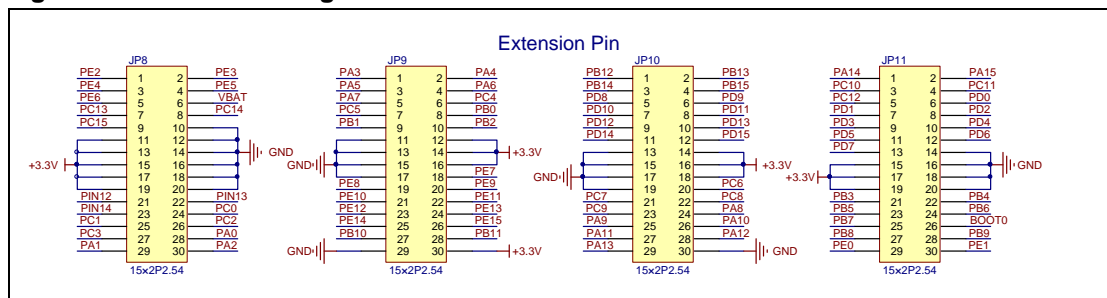

5 Revision history

Table 3. Revision history

Revision No.	Description	Date
1.0	Initial Release	Sept.9, 2013

单击下面可查看定价，库存，交付和生命周期等信息

[>>GigaDevice\(兆易创新\)](#)