

GigaDevice Semiconductor Inc.

GD32E230xx
ARM[®] Cortex[®]-M23 32-bit MCU

Datasheet

Table of Contents

Table of Contents	1
List of Figures	4
List of Tables	5
1 General description	7
2 Device overview	8
2.1 Device information	8
2.2 Block diagram.....	10
2.3 Pinouts and pin assignment	11
2.4 Memory map	13
2.5 Clock tree	15
2.6 Pin definitions.....	16
2.6.1 GD32E230Cx LQFP48 pin definitions	16
2.6.2 GD32E230Kx LQFP32 pin definitions.....	19
2.6.3 GD32E230Kx QFN32 pin definitions	21
2.6.4 GD32E230Gx QFN28 pin definitions	23
2.6.5 GD32E230Fx TSSOP20 pin definitions	26
2.6.6 GD32E230xx pin alternate functions	28
3 Functional description	31
3.1 ARM® Cortex®-M23 core	31
3.2 Embedded memory	31
3.3 Clock, reset and supply management.....	32
3.4 Boot modes.....	32
3.5 Power saving modes	33
3.6 Analog to digital converter (ADC)	33
3.7 DMA.....	34
3.8 General-purpose inputs/outputs (GPIOs)	34
3.9 Timers and PWM generation.....	34
3.10 Real time clock (RTC)	35
3.11 Inter-integrated circuit (I2C)	36
3.12 Serial peripheral interface (SPI)	36
3.13 Universal synchronous asynchronous receiver transmitter (USART)	37

3.14	Inter-IC sound (I2S)	37
3.15	Comparators (CMP).....	37
3.16	Debug mode	38
3.17	Package and operation temperature.....	38
4	Electrical characteristics.....	39
4.1	Absolute maximum ratings	39
4.2	Operating conditions characteristics	39
4.3	Power consumption	40
4.4	EMC characteristics	44
4.5	Power supply supervisor characteristics	46
4.6	Electrical sensitivity	46
4.7	External clock characteristics	47
4.8	Internal clock characteristics	49
4.9	PLL characteristics.....	50
4.10	Memory characteristics	50
4.11	NRST pin characteristics	50
4.12	GPIO characteristics	51
4.13	ADC characteristics	54
4.14	Temperature sensor characteristics	55
4.15	Comparators characteristics.....	55
4.16	TIMER characteristics	56
4.17	WDGT characteristics	56
4.18	I2C characteristics	57
4.19	SPI characteristics	57
4.20	I2S characteristics.....	58
4.21	USART characteristics.....	59
5	Package information.....	60
5.1	TSSOP package outline dimensions	60
5.2	QFN package outline dimensions	61
5.3	LQFP package outline dimensions	63
6	Ordering information	65
7	Revision history	66

List of Figures

Figure 2-1. GD32E230xx block diagram.....	10
Figure 2-2. GD32E230Cx LQFP48 pinouts	11
Figure 2-3. GD32E230Kx LQFP32 pinouts	11
Figure 2-4. GD32E230Kx QFN32 pinouts	12
Figure 2-5. GD32E230Gx QFN28 pinouts.....	12
Figure 2-6. GD32E230Fx TSSOP20 pinouts	12
Figure 2-7. GD32E230xx clock tree	15
Figure 4-1. I/O port AC characteristics definition	54
Figure 5-1. TSSOP package outline	60
Figure 5-2. QFN package outline.....	61
Figure 5-3. LQFP package outline.....	63

List of Tables

Table 2-1. GD32E230xx devices features and peripheral list.....	8
Table 2-2. GD32E230xx devices features and peripheral list (continued).....	9
Table 2-3. GD32E230xx memory map	13
Table 2-4. GD32E230Cx LQFP48 pin definitions.....	16
Table 2-5. GD32E230Kx LQFP32 pin definitions.....	19
Table 2-6. GD32E230Kx QFN32 pin definitions	21
Table 2-7. GD32E230Gx QFN28 pin definitions	23
Table 2-8. GD32E230Fx TSSOP20 pin definitions	26
Table 2-9. Port A alternate functions summary	28
Table 2-10. Port B alternate functions summary	29
Table 2-11. Port F alternate functions summary.....	30
Table 4-1. Absolute maximum ratings	39
Table 4-2. DC operating conditions.....	39
Table 4-3. Clock frequency.....	40
Table 4-4. Operating conditions at Power up/ Power down	40
Table 4-5. Start-up timings of Operating conditions	40
Table 4-6. Power saving mode wakeup timings characteristics.....	40
Table 4-7. Power consumption characteristics	40
Table 4-8. Peripheral current consumption characteristics.....	43
Table 4-9. EMS characteristics	44
Table 4-10. EMI characteristics	45
Table 4-11. Power supply supervisor characteristics	46
Table 4-12. ESD characteristics	47
Table 4-13. Static latch-up characteristics.....	47
Table 4-14. High speed external clock (HXTAL) generated from a crystal/ceramic characteristics	47
Table 4-15. High speed external user clock characteristics (HXTAL in bypass mode)	47
Table 4-16. Low speed external clock (LXTAL) generated from a crystal/ceramic characteristics... ..	48
Table 4-17. Low speed external clock (LXTAL) generated from an external clock source/oscillator characteristics	48
Table 4-18. High speed internal clock (IRC8M) characteristics ⁽¹⁾	49
Table 4-19. High speed internal clock (IRC28M) characteristics ⁽¹⁾	49
Table 4-20. Low speed internal clock (IRC40K) characteristics ⁽¹⁾	49
Table 4-21. PLL characteristics	50
Table 4-22. Flash memory characteristics.....	50
Table 4-23. NRST pin characteristics.....	50
Table 4-24. I/O port DC characteristics	51
Table 4-25. I/O port AC characteristics ^{(1) (2)}	52
Table 4-26. Temperature sensor characteristics	55
Table 4-27. CMP characteristics.....	55
Table 4-28. TIMER characteristics.....	56

Table 4-29. FWDGT min/max timeout period at 40 kHz (IRC40K).....	56
Table 4-30. WWDGT min-max timeout value @72 MHz (f_{PCLK1})	57
Table 4-31. I2C characteristics	57
Table 4-32. Standard SPI characteristics ⁽¹⁾	57
Table 4-33. I2S characteristics ⁽¹⁾	58
Table 4-34. USART characteristics ⁽¹⁾	59
Table 5-1. TSSOP20 package dimensions	60
Table 5-2. QFN package dimensions.....	62
Table 5-3. LQFP package dimensions.....	64
Table 6-1. Part ordering code for GD32E230xx devices	65
Table 7-1. Revision history	66

1 General description

The GD32E230xx device belongs to the value line of GD32 MCU family. It is a new 32-bit general-purpose microcontroller based on the ARM® Cortex®-M23 RISC core. The Cortex-M23 processor is an energy-efficient processor with a very low gate count. It is intended to be used for microcontroller and deeply embedded applications that require an area-optimized processor. The processor delivers high energy efficiency through a small but powerful instruction set and extensively optimized design, providing high-end processing hardware including a single-cycle multiplier and a 17-cycle divider.

The GD32E230xx device incorporates the ARM® Cortex®-M23 32-bit processor core operating at up to 72 MHz frequency with Flash accesses 0~2 wait states to obtain maximum efficiency. It provides up to 64 KB embedded Flash memory and up to 8 KB SRAM memory. An extensive range of enhanced I/Os and peripherals connected to two APB buses. The devices offer one 12-bit ADC and one comparator, up to five general 16-bit timers, a basic timer, a PWM advanced timer, as well as standard and advanced communication interfaces: up to two SPIs, two I2Cs, two USARTs, and an I2S.

The device operates from a 1.8 to 3.6 V power supply and available in –40 to +85 °C temperature range. Several power saving modes provide the flexibility for maximum optimization between wakeup latency and power consumption, an especially important consideration in low power applications.

The above features make the GD32E230xx devices suitable for a wide range of applications, especially in areas such as industrial control, motor drives, user interface, power monitor and alarm systems, consumer and handheld equipment, gaming and GPS, E-bike and so on.



2 Device overview

2.1 Device information

Table 2-1. GD32E230xx devices features and peripheral list

Part Number		GD32E230xx								
		K4U6	K6U6	K8U6	K4T6	K6T6	K8T6	C4T6	C6T6	C8T6
Flash	Code area (KB)	16	32	64	16	32	64	16	32	64
	Data area (KB)	0	0	0	0	0	0	0	0	0
	Total (KB)	16	32	64	16	32	64	16	32	64
SRAM (KB)		4	6	8	4	4	8	4	6	8
Timers	General timer(16-bit)	4 <small>(2,13,15,16)</small>	4 <small>(2,13,15,16)</small>	5 <small>(2,13-16)</small>	4 <small>(2,13,15,16)</small>	4 <small>(2,13,15,16)</small>	5 <small>(2,13-16)</small>	4 <small>(2,13,15,16)</small>	4 <small>(2,13,15,16)</small>	5 <small>(2,13-16)</small>
	Advanced timer(16-bit)	1 <small>(0)</small>	1 <small>(0)</small>	1 <small>(0)</small>	1 <small>(0)</small>	1 <small>(0)</small>	1 <small>(0)</small>	1 <small>(0)</small>	1 <small>(0)</small>	1 <small>(0)</small>
	SysTick	1	1	1	1	1	1	1	1	1
	Basic timer(16-bit)	1 <small>(5)</small>	1 <small>(5)</small>	1 <small>(5)</small>	1 <small>(5)</small>	1 <small>(5)</small>	1 <small>(5)</small>	1 <small>(5)</small>	1 <small>(5)</small>	1 <small>(5)</small>
	Watchdog	2	2	2	2	2	2	2	2	2
	RTC	1	1	1	1	1	1	1	1	1
Connectivity	USART	1 <small>(0)</small>	2 <small>(0-1)</small>	2 <small>(0-1)</small>	1 <small>(0)</small>	2 <small>(0-1)</small>	2 <small>(0-1)</small>	1 <small>(0)</small>	2 <small>(0-1)</small>	2 <small>(0-1)</small>
	I2C	1 <small>(0)</small>	1 <small>(0)</small>	2 <small>(0-1)</small>	1 <small>(0)</small>	1 <small>(0)</small>	2 <small>(0-1)</small>	1 <small>(0)</small>	1 <small>(0)</small>	2 <small>(0-1)</small>
	SPI/I2S	1/1 <small>(0)/(0)</small>	1/1 <small>(0)/(0)</small>	2/1 <small>(0-1)/(0)</small>	1/1 <small>(0)/(0)</small>	1/1 <small>(0)/(0)</small>	2/1 <small>(0-1)/(0)</small>	1/1 <small>(0)/(0)</small>	1/1 <small>(0)/(0)</small>	2/1 <small>(0-1)/(0)</small>
GPIO		27	27	27	25	25	25	39	39	39
CMP		1	1	1	1	1	1	1	1	1
EXTI		16	16	16	16	16	16	16	16	16
ADC	Units	1	1	1	1	1	1	1	1	1
	Channels (External)	10	10	10	10	10	10	10	10	10
	Channels (Internal)	2	2	2	2	2	2	2	2	2
Package		QFN32			LQFP32			LQFP48		

Table 2-2. GD32E230xx devices features and peripheral list (continued)

Part Number		GD32E230xx					
		F4P6	F6P6	F8P6	G4U6	G6U6	G8U6
Flash	Code area (KB)	16	32	64	16	32	64
	Data area (KB)	0	0	0	0	0	0
	Total (KB)	16	32	64	16	32	64
SRAM (KB)		4	6	8	4	6	8
Timers	General timer(16-bit)	4 <small>(2,13,15,16)</small>	4 <small>(2,13,15,16)</small>	4 <small>(2,13,15,16)</small>	4 <small>(2,13,15,16)</small>	4 <small>(2,13,15,16)</small>	5 <small>(2,13-16)</small>
	Advanced timer(16-bit)	1 <small>(0)</small>	1 <small>(0)</small>	1 <small>(0)</small>	1 <small>(0)</small>	1 <small>(0)</small>	1 <small>(0)</small>
	SysTick	1	1	1	1	1	1
	Basic timer(16-bit)	1 <small>(5)</small>	1 <small>(5)</small>	1 <small>(5)</small>	1 <small>(5)</small>	1 <small>(5)</small>	1 <small>(5)</small>
	Watchdog	2	2	2	2	2	2
	RTC	1	1	1	1	1	1
Connectivity	USART	1 <small>(0)</small>	2 <small>(0-1)</small>	2 <small>(0-1)</small>	1 <small>(0)</small>	2 <small>(0-1)</small>	2 <small>(0-1)</small>
	I2C	1 <small>(0)</small>	1 <small>(0)</small>	2 <small>(0-1)</small>	1 <small>(0)</small>	1 <small>(0)</small>	2 <small>(0-1)</small>
	SPI/I2S	1/1 <small>(0)/(0)</small>	1/1 <small>(0)/(0)</small>	2/1 <small>(0-1)/(0)</small>	1/1 <small>(0)/(0)</small>	1/1 <small>(0)/(0)</small>	2/1 <small>(0-1)/(0)</small>
GPIO		15	15	15	23	23	23
CMP		1	1	1	1	1	1
EXTI		16	16	16	16	16	16
ADC	Units	1	1	1	1	1	1
	Channels (External)	9	9	9	10	10	10
	Channels (Internal)	2	2	2	2	2	2
Package		TSSOP20			QFN28		

2.2 Block diagram

Figure 2-1. GD32E230xx block diagram

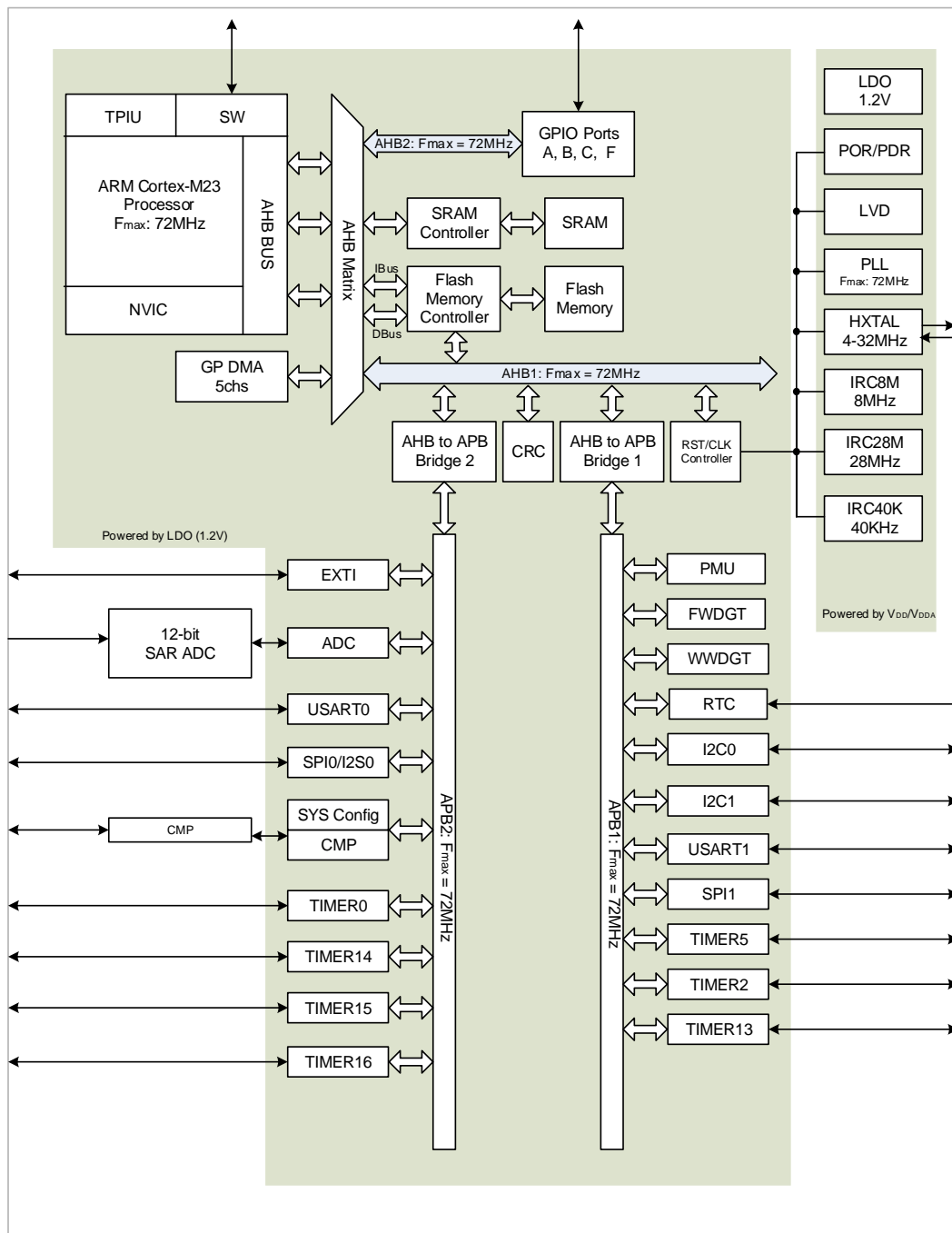

2.3 Pinouts and pin assignment

Figure 2-2. GD32E230Cx LQFP48 pinouts

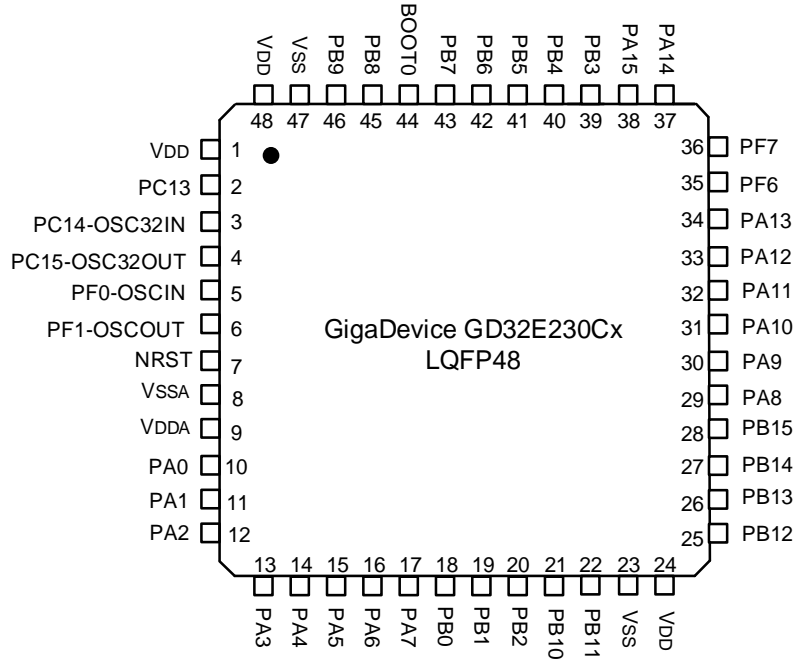

Figure 2-3. GD32E230Kx LQFP32 pinouts

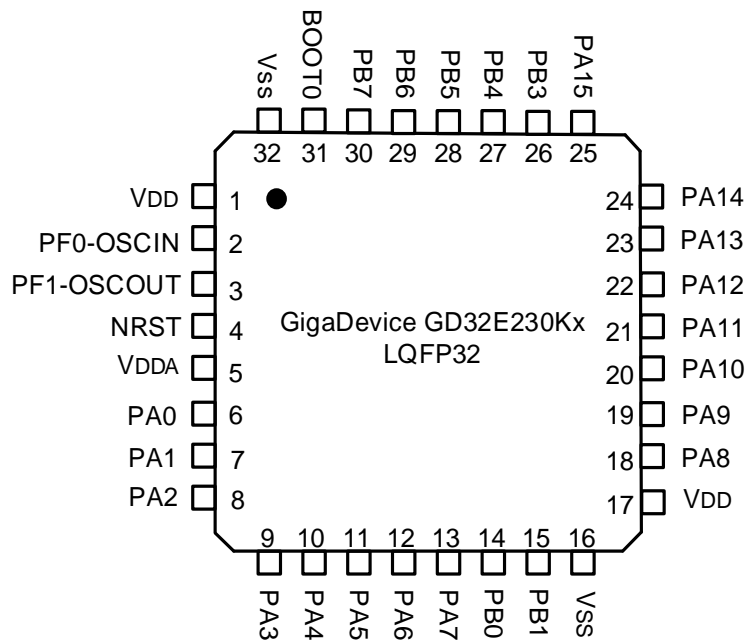

Figure 2-4. GD32E230Kx QFN32 pinouts

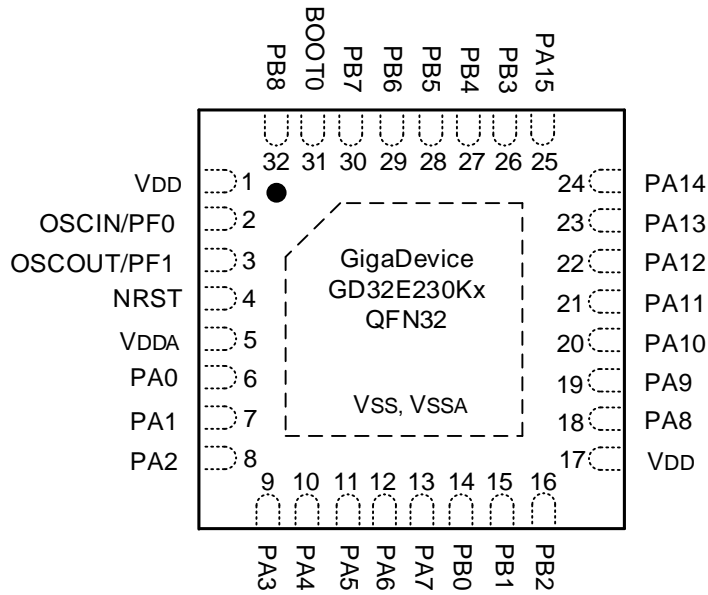

Figure 2-5. GD32E230Gx QFN28 pinouts

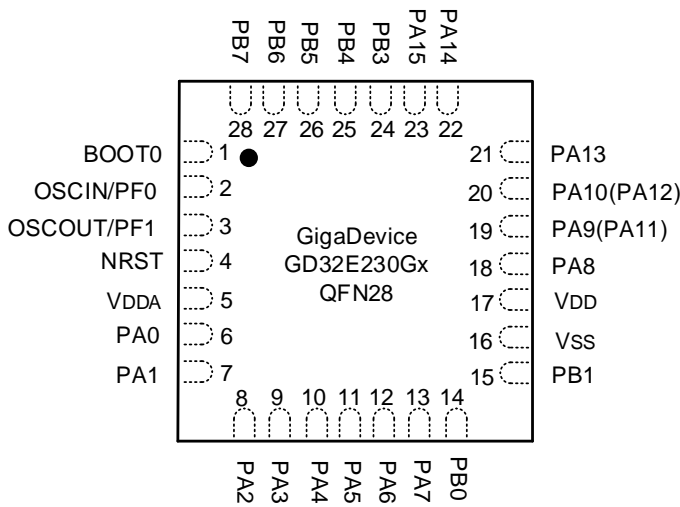
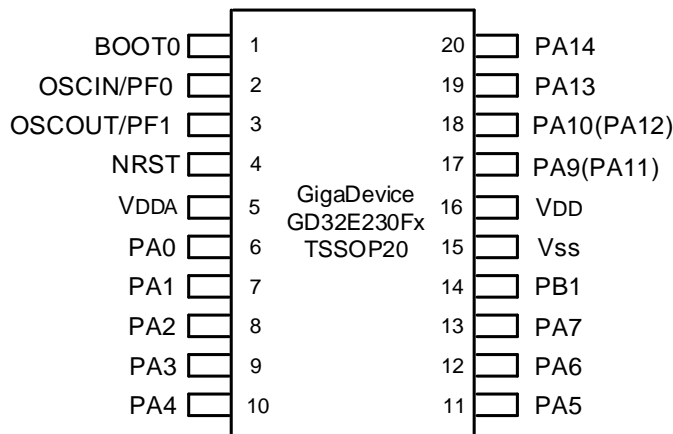

Figure 2-6. GD32E230Fx TSSOP20 pinouts



2.4 Memory map

Table 2-3. GD32E230xx memory map

Pre-defined Regions	Bus	ADDRESS	Peripherals
		0xE000 0000 - 0xE00F FFFF	Cortex M23 internal peripherals
External Device		0xA000 0000 - 0xDFFF FFFF	Reserved
External RAM		0x60000000 - 0x9FFFFFFF	Reserved
Peripherals	AHB1	0x5004 0000 - 0x5FFF FFFF	Reserved
		0x5000 0000 - 0x5003 FFFF	Reserved
	AHB2	0x4800 1800 - 0x4FFF FFFF	Reserved
		0x4800 1400 - 0x4800 17FF	GPIOF
		0x4800 1000 - 0x4800 13FF	Reserved
		0x4800 0C00 - 0x4800 0FFF	Reserved
		0x4800 0800 - 0x4800 0BFF	GPIOC
		0x4800 0400 - 0x4800 07FF	GPIOB
		0x4800 0000 - 0x4800 03FF	GPIOA
	AHB1	0x4002 4400 - 0x47FF FFFF	Reserved
		0x4002 4000 - 0x4002 43FF	Reserved
		0x4002 3400 - 0x4002 3FFF	Reserved
		0x4002 3000 - 0x4002 33FF	CRC
		0x4002 2400 - 0x4002 2FFF	Reserved
		0x4002 2000 - 0x4002 23FF	FMC
		0x4002 1400 - 0x4002 1FFF	Reserved
		0x4002 1000 - 0x4002 13FF	RCU
		0x4002 0400 - 0x4002 0FFF	Reserved
		0x4002 0000 - 0x4002 03FF	DMA
	APB2	0x4001 8000 - 0x4001 FFFF	Reserved
		0x4001 5C00 - 0x4001 7FFF	Reserved
		0x4001 5800 - 0x4001 5BFF	DBG
		0x4001 4C00 - 0x4001 57FF	Reserved
		0x4001 4800 - 0x4001 4BFF	TIMER16
		0x4001 4400 - 0x4001 47FF	TIMER15
		0x4001 4000 - 0x4001 43FF	TIMER14
		0x4001 3C00 - 0x4001 3FFF	Reserved
		0x4001 3800 - 0x4001 3BFF	USART0
		0x4001 3400 - 0x4001 37FF	Reserved
		0x4001 3000 - 0x4001 33FF	SPI0/I2S0
		0x4001 2C00 - 0x4001 2FFF	TIMER0
		0x4001 2800 - 0x4001 2BFF	Reserved
0x4001 2400 - 0x4001 27FF		ADC	
0x4001 0800 - 0x4001 23FF		Reserved	

Pre-defined Regions	Bus	ADDRESS	Peripherals
		0x4001 0400 - 0x4001 07FF	EXTI
		0x4001 0000 - 0x4001 03FF	SYSCFG + CMP
	APB1	0x4000 CC00 - 0x4000 FFFF	Reserved
		0x4000 C800 - 0x4000 CBFF	Reserved
		0x4000 C400 - 0x4000 C7FF	Reserved
		0x4000 C000 - 0x4000 C3FF	Reserved
		0x4000 8000 - 0x4000 BFFF	Reserved
		0x4000 7C00 - 0x4000 7FFF	Reserved
		0x4000 7800 - 0x4000 7BFF	Reserved
		0x4000 7400 - 0x4000 77FF	Reserved
		0x4000 7000 - 0x4000 73FF	PMU
		0x4000 6400 - 0x4000 6FFF	Reserved
		0x4000 6000 - 0x4000 63FF	Reserved
		0x4000 5C00 - 0x4000 5FFF	Reserved
		0x4000 5800 - 0x4000 5BFF	I2C1
		0x4000 5400 - 0x4000 57FF	I2C0
		0x4000 4800 - 0x4000 53FF	Reserved
		0x4000 4400 - 0x4000 47FF	USART1
		0x4000 4000 - 0x4000 43FF	Reserved
		0x4000 3C00 - 0x4000 3FFF	Reserved
		0x4000 3800 - 0x4000 3BFF	SPI1
		0x4000 3400 - 0x4000 37FF	Reserved
		0x4000 3000 - 0x4000 33FF	FWDGT
		0x4000 2C00 - 0x4000 2FFF	WWDGT
		0x4000 2800 - 0x4000 2BFF	RTC
		0x4000 2400 - 0x4000 27FF	Reserved
		0x4000 2000 - 0x4000 23FF	TIMER13
		0x4000 1400 - 0x4000 1FFF	Reserved
		0x4000 1000 - 0x4000 13FF	TIMER5
		0x4000 0800 - 0x4000 0FFF	Reserved
		0x4000 0400 - 0x4000 07FF	TIMER2
		0x4000 0000 - 0x4000 03FF	Reserved
SRAM		0x2000 2000 - 0x3FFF FFFF	Reserved
		0x2000 0000 - 0x2000 1FFF	SRAM
Code		0x1FFF F810 - 0x1FFF FFFF	Reserved
		0x1FFF F800 - 0x1FFF F80F	Option bytes
		0x1FFF EC00 - 0x1FFF F7FF	System memory
		0x0801 0000 - 0x1FFF EBFF	Reserved
		0x0800 0000 - 0x0800 FFFF	Main Flash memory
		0x0001 0000 - 0x07FF FFFF	Reserved

Pre-defined Regions	Bus	ADDRESS	Peripherals
		0x00000000 - 0x0000FFFF	Aliased to Flash or system memory

2.5 Clock tree

Figure 2-7. GD32E230xx clock tree

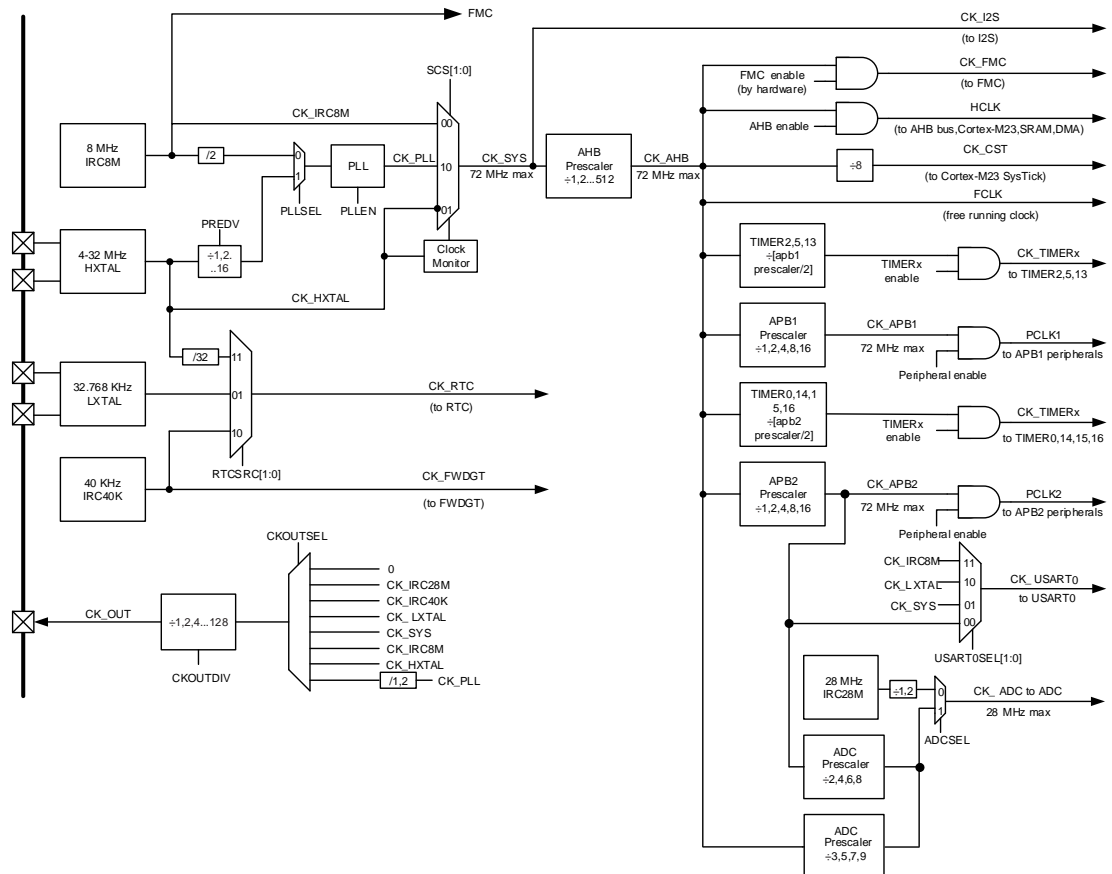

Note:

If the APB prescaler is 1, the timer clock frequencies are set to AHB frequency divide by 1. Otherwise, they are set to the AHB frequency divide by half of APB prescaler.

Legend:

- HXTAL: High speed crystal oscillator
- LXTAL: Low speed crystal oscillator
- IRC8M: Internal 8M RC oscillator
- IRC40K: Internal 40K RC oscillator
- IRC28M: Internal 28M RC oscillator

2.6 Pin definitions

2.6.1 GD32E230Cx LQFP48 pin definitions

Table 2-4. GD32E230Cx LQFP48 pin definitions

Pin Name	Pins	Pin Type ⁽¹⁾	I/O Level ⁽²⁾	Functions description
V _{DD}	1	P		Default: V _{DD}
PC13-TAMPER-RTC	2	I/O		Default: PC13 Additional: RTC_TAMP0, RTC_TS, RTC_OUT, WKUP1
PC14-OSC32IN	3	I/O		Default: PC14 Additional: OSC32IN
PC15-OSC32OUT	4	I/O		Default: PC15 Additional: OSC32OUT
PF0-OSCIN	5	I/O	5VT	Default: PF0 Alternate: I2C0_SDA Additional: OSCIN
PF1-OSCOU	6	I/O	5VT	Default: PF1 Alternate: I2C0_SCL Additional: OSCOUT
NRST	7	I/O		Default: NRST
V _{SSA}	8	P		Default: V _{SSA}
V _{DDA}	9	P		Default: V _{DDA}
PA0-WKUP	10	I/O		Default: PA0 Alternate: USART0_CTS ⁽³⁾ , USART1_CTS ⁽⁴⁾ , CMP_OUT, I2C1_SCL ⁽⁵⁾ Additional: ADC_IN0, CMP_IM6, RTC_TAMP1, WKUP0
PA1	11	I/O		Default: PA1 Alternate: USART0_RTS ⁽³⁾ , USART1_RTS ⁽⁴⁾ , I2C1_SDA ⁽⁵⁾ , EVENTOUT, TIMER14_CH0_ON ⁽⁵⁾ Additional: ADC_IN1, CMP_IP
PA2	12	I/O		Default: PA2 Alternate: USART0_TX ⁽³⁾ , USART1_TX ⁽⁴⁾ , TIMER14_CH0 ⁽⁵⁾ Additional: ADC_IN2, CMP_IM7
PA3	13	I/O		Default: PA3 Alternate: USART0_RX ⁽³⁾ , USART1_RX ⁽⁴⁾ , TIMER14_CH1 ⁽⁵⁾ Additional: ADC_IN3
PA4	14	I/O		Default: PA4 Alternate: SPI0_NSS, I2S0_WS, USART0_CK ⁽³⁾ , USART1_CK ⁽⁴⁾ , TIMER13_CH0, SPI1_NSS ⁽⁵⁾ Additional: ADC_IN4, CMP_IM4

Pin Name	Pins	Pin Type ⁽¹⁾	I/O Level ⁽²⁾	Functions description
PA5	15	I/O		Default: PA5 Alternate: SPI0_SCK, I2S0_CK Additional: ADC_IN5, CMP_IM5
PA6	16	I/O		Default: PA6 Alternate: SPI0_MISO, I2S0_MCK, TIMER2_CH0, TIMER0_BRKIN, TIMER15_CH0, EVENTOUT, CMP_OUT Additional: ADC_IN6
PA7	17	I/O		Default: PA7 Alternate: SPI0_MOSI, I2S0_SD, TIMER2_CH1, TIMER13_CH0, TIMER0_CH0_ON, TIMER16_CH0, EVENTOUT Additional: ADC_IN7
PB0	18	I/O		Default: PB0 Alternate: TIMER2_CH2, TIMER0_CH1_ON, USART1_RX ⁽⁴⁾ , EVENTOUT Additional: ADC_IN8
PB1	19	I/O		Default: PB1 Alternate: TIMER2_CH3, TIMER13_CH0, TIMER0_CH2_ON, SPI1_SCK ⁽⁵⁾ Additional: ADC_IN9
PB2	20	I/O	5VT	Default: PB2 Alternate: TIMER2_ETI
PB10	21	I/O	5VT	Default: PB10 Alternate: I2C0_SCL ⁽³⁾ , I2C1_SCL ⁽⁵⁾ , SPI1_IO2 ⁽⁵⁾ , SPI1_SCK
PB11	22	I/O	5VT	Default: PB11 Alternate: I2C0_SDA ⁽³⁾ , I2C1_SDA ⁽⁵⁾ , EVENTOUT, SPI1_IO3 ⁽⁵⁾
V _{SS}	23	P		Default: V _{SS}
V _{DD}	24	P		Default: V _{DD}
PB12	25	I/O	5VT	Default: PB12 Alternate: SPI0_NSS ⁽³⁾ , SPI1_NSS ⁽⁵⁾ , TIMER0_BRKIN, I2C1_SMBA ⁽⁵⁾ , EVENTOUT
PB13	26	I/O	5VT	Default: PB13 Alternate: SPI0_SCK ⁽³⁾ , SPI1_SCK ⁽⁵⁾ , TIMER0_CH0_ON, I2C1_TXFRAME ⁽⁵⁾ , I2C1_SCL ⁽⁵⁾
PB14	27	I/O	5VT	Default: PB14 Alternate: SPI0_MISO ⁽³⁾ , SPI1_MISO ⁽⁵⁾ , TIMER0_CH1_ON, TIMER14_CH0 ⁽⁵⁾ , I2C1_SDA ⁽⁵⁾
PB15	28	I/O	5VT	Default: PB15 Alternate: SPI0_MOSI ⁽³⁾ , SPI1_MOSI ⁽⁵⁾ , TIMER0_CH2_ON, TIMER14_CH0_ON ⁽⁵⁾ , TIMER14_CH1 ⁽⁵⁾ Additional: RTC_REFIN, WKUP6

Pin Name	Pins	Pin Type ⁽¹⁾	I/O Level ⁽²⁾	Functions description
PA8	29	I/O	5VT	Default: PA8 Alternate: USART0_CK, TIMER0_CH0, CK_OUT, USART1_TX ⁽⁴⁾ , EVENTOUT
PA9	30	I/O	5VT	Default: PA9 Alternate: USART0_TX, TIMER0_CH1, TIMER14_BRKIN ⁽⁵⁾ , I2C0_SCL, CK_OUT
PA10	31	I/O	5VT	Default: PA10 Alternate: USART0_RX, TIMER0_CH2, TIMER16_BRKIN, I2C0_SDA
PA11	32	I/O	5VT	Default: PA11 Alternate: USART0_CTS, TIMER0_CH3, CMP_OUT, EVENTOUT, SPI1_IO2 ⁽⁵⁾ , I2C0_SMBA, I2C1_SCL ⁽⁵⁾
PA12	33	I/O	5VT	Default: PA12 Alternate: USART0_RTS, TIMER0_ETI, EVENTOUT, SPI1_IO3 ⁽⁵⁾ , I2C0_TXFRAME, I2C1_SDA ⁽⁵⁾
PA13	34	I/O	5VT	Default: PA13 Alternate: SWDIO, IFRP_OUT, SPI1_MISO ⁽⁵⁾
PF6	35	I/O	5VT	Default: PF6 Alternate: I2C0_SCL ⁽³⁾ , I2C1_SCL ⁽⁵⁾
PF7	36	I/O	5VT	Default: PF7 Alternate: I2C0_SDA ⁽³⁾ , I2C1_SDA ⁽⁵⁾
PA14	37	I/O	5VT	Default: PA14 Alternate: USART0_TX ⁽³⁾ , USART1_TX ⁽⁴⁾ , SWCLK, SPI1_MOSI ⁽⁵⁾
PA15	38	I/O	5VT	Default: PA15 Alternate: SPI0_NSS, I2S0_WS, USART0_RX ⁽³⁾ , USART1_RX ⁽⁴⁾ , SPI1_NSS ⁽⁵⁾ , EVENTOUT
PB3	39	I/O	5VT	Default: PB3 Alternate: SPI0_SCK, I2S0_CK, EVENTOUT
PB4	40	I/O	5VT	Default: PB4 Alternate: SPI0_MISO, I2S0_MCK, TIMER2_CH0, EVENTOUT, I2C0_TXFRAME, TIMER16_BRKIN
PB5	41	I/O	5VT	Default: PB5 Alternate: SPI0_MOSI, I2S0_SD, I2C0_SMBA, TIMER15_BRKIN, TIMER2_CH1 Additional: WKUP5
PB6	42	I/O	5VT	Default: PB6 Alternate: I2C0_SCL, USART0_TX, TIMER15_CH0_ON
PB7	43	I/O	5VT	Default: PB7 Alternate: I2C0_SDA, USART0_RX, TIMER16_CH0_ON
BOOT0	44	I		Default: BOOT0
PB8	45	I/O	5VT	Default: PB8 Alternate: I2C0_SCL, TIMER15_CH0
PB9	46	I/O	5VT	Default: PB9 Alternate: I2C0_SDA, IFRP_OUT, TIMER16_CH0,

Pin Name	Pins	Pin Type ⁽¹⁾	I/O Level ⁽²⁾	Functions description
				EVENTOUT, I2S0_MCK, SPI1_NSS ⁽⁵⁾
V _{SS}	47	P		Default: V _{SS}
V _{DD}	48	P		Default: V _{DD}

Notes:

- (1) Type: I = input, O = output, P = power.
- (2) I/O Level: 5VT = 5 V tolerant.
- (3) Functions are available on GD32E230C4 devices only.
- (4) Functions are available on GD32E230C8/6 devices.
- (5) Functions are available on GD32E230C8 devices only.

2.6.2 GD32E230Kx LQFP32 pin definitions

Table 2-5. GD32E230Kx LQFP32 pin definitions

Pin Name	Pins	Pin Type ⁽¹⁾	I/O Level ⁽²⁾	Functions description
V _{DD}	1	P		Default: V _{DD}
PF0-OSCIN	2	I/O	5VT	Default: PF0 Alternate: I2C0_SDA Additional: OSCIN
PF1-OSCOU	3	I/O	5VT	Default: PF1 Alternate: I2C0_SCL Additional: OSCOUT
NRST	4	I/O		Default: NRST
V _{DDA}	5	P		Default: V _{DDA}
PA0-WKUP	6	I/O		Default: PA0 Alternate: USART0_CTS ⁽³⁾ , USART1_CTS ⁽⁴⁾ , CMP_OUT, I2C1_SCL ⁽⁵⁾ Additional: ADC_IN0, CMP_IM6, RTC_TAMP1, WKUP0
PA1	7	I/O		Default: PA1 Alternate: USART0_RTS ⁽³⁾ , USART1_RTS ⁽⁴⁾ , I2C1_SDA ⁽⁵⁾ , EVENTOUT, TIMER14_CH0_ON ⁽⁵⁾ Additional: ADC_IN1, CMP_IP
PA2	8	I/O		Default: PA2 Alternate: USART0_TX ⁽³⁾ , USART1_TX ⁽⁴⁾ , TIMER14_CH0 ⁽⁵⁾ Additional: ADC_IN2, CMP_IM7
PA3	9	I/O		Default: PA3 Alternate: USART0_RX ⁽³⁾ , USART1_RX ⁽⁴⁾ , TIMER14_CH1 ⁽⁵⁾ Additional: ADC_IN3
PA4	10	I/O		Default: PA4 Alternate: SPI0_NSS, I2S0_WS, USART0_CK ⁽³⁾ , USART1_CK ⁽⁴⁾ , TIMER13_CH0, SPI1_NSS ⁽⁵⁾

Pin Name	Pins	Pin Type ⁽¹⁾	I/O Level ⁽²⁾	Functions description
				Additional: ADC_IN4, CMP_IM4
PA5	11	I/O		Default: PA5 Alternate: SPI0_SCK, I2S0_CK Additional: ADC_IN5, CMP_IM5
PA6	12	I/O		Default: PA6 Alternate: SPI0_MISO, I2S0_MCK, TIMER2_CH0, TIMER0_BRKIN, TIMER15_CH0, EVENTOUT, CMP_OUT Additional: ADC_IN6
PA7	13	I/O		Default: PA7 Alternate: SPI0_MOSI, I2S0_SD, TIMER2_CH1, TIMER13_CH0, TIMER0_CH0_ON, TIMER16_CH0, EVENTOUT Additional: ADC_IN7
PB0	14	I/O		Default: PB0 Alternate: TIMER2_CH2, TIMER0_CH1_ON, USART1_RX ⁽⁴⁾ , EVENTOUT Additional: ADC_IN8
PB1	15	I/O		Default: PB1 Alternate: TIMER2_CH3, TIMER13_CH0, TIMER0_CH2_ON, SPI1_SCK ⁽⁵⁾ Additional: ADC_IN9
V _{SS}	16	P		Default: V _{SS}
V _{DD}	17	P		Default: V _{DD}
PA8	18	I/O	5VT	Default: PA8 Alternate: USART0_CK, TIMER0_CH0, CK_OUT, USART1_TX ⁽⁴⁾ , EVENTOUT
PA9	19	I/O	5VT	Default: PA9 Alternate: USART0_TX, TIMER0_CH1, TIMER14_BRKIN ⁽⁵⁾ , I2C0_SCL, CK_OUT
PA10	20	I/O	5VT	Default: PA10 Alternate: USART0_RX, TIMER0_CH2, TIMER16_BRKIN, I2C0_SDA
PA11	21	I/O	5VT	Default: PA11 Alternate: USART0_CTS, TIMER0_CH3, CMP_OUT, EVENTOUT, SPI1_IO2 ⁽⁵⁾ , I2C0_SMBA, I2C1_SCL ⁽⁵⁾
PA12	22	I/O	5VT	Default: PA12 Alternate: USART0_RTS, TIMER0_ETI, EVENTOUT, SPI1_IO3 ⁽⁵⁾ , I2C0_TXFRAME, I2C1_SDA ⁽⁵⁾
PA13	23	I/O	5VT	Default: PA13 Alternate: SWDIO, IFRP_OUT, SPI1_MISO ⁽⁵⁾
PA14	24	I/O	5VT	Default: PA14 Alternate: USART0_TX ⁽³⁾ , USART1_TX ⁽⁴⁾ , SWCLK, SPI1_MOSI ⁽⁵⁾
PA15	25	I/O	5VT	Default: PA15 Alternate: SPI0_NSS, I2S0_WS, USART0_RX ⁽³⁾ ,

Pin Name	Pins	Pin Type ⁽¹⁾	I/O Level ⁽²⁾	Functions description
				USART1_RX ⁽⁴⁾ , SPI1_NSS ⁽⁵⁾ , EVENTOUT
PB3	26	I/O	5VT	Default: PB3 Alternate: SPI0_SCK, I2S0_CK, EVENTOUT
PB4	27	I/O	5VT	Default: PB4 Alternate: SPI0_MISO, I2S0_MCK, TIMER2_CH0, EVENTOUT, I2C0_TXFRAME, TIMER16_BRKIN
PB5	28	I/O	5VT	Default: PB5 Alternate: SPI0_MOSI, I2S0_SD, I2C0_SMBA, TIMER15_BRKIN, TIMER2_CH1 Additional: WKUP5
PB6	29	I/O	5VT	Default: PB6 Alternate: I2C0_SCL, USART0_TX, TIMER15_CH0_ON
PB7	30	I/O	5VT	Default: PB7 Alternate: I2C0_SDA, USART0_RX, TIMER16_CH0_ON
BOOT0	31	I		Default: BOOT0
V _{SS}	32	P		Default: V _{SS}

Notes:

- (1) Type: I = input, O = output, P = power.
- (2) I/O Level: 5VT = 5 V tolerant.
- (3) Functions are available on GD32E230K4 devices only.
- (4) Functions are available on GD32E230K8/6 devices.
- (5) Functions are available on GD32E230K8 devices only.

2.6.3 GD32E230Kx QFN32 pin definitions

Table 2-6. GD32E230Kx QFN32 pin definitions

Pin Name	Pins	Pin Type ⁽¹⁾	I/O Level ⁽²⁾	Functions description
V _{DD}	1	P		Default: V _{DD}
PF0-OSCIN	2	I/O	5VT	Default: PF0 Alternate: I2C0_SDA Additional: OSCIN
PF1-OSCOUT	3	I/O	5VT	Default: PF1 Alternate: I2C0_SCL Additional: OSCOUT
NRST	4	I/O		Default: NRST
V _{DDA}	5	P		Default: V _{DDA}
PA0-WKUP	6	I/O		Default: PA0 Alternate: USART0_CTS ⁽³⁾ , USART1_CTS ⁽⁴⁾ , CMP_OUT, I2C1_SCL ⁽⁵⁾ Additional: ADC_IN0, CMP_IM6, RTC_TAMP1, WKUP0
PA1	7	I/O		Default: PA1 Alternate: USART0_RTS ⁽³⁾ , USART1_RTS ⁽⁴⁾ , I2C1_SDA ⁽⁵⁾ , EVENTOUT, TIMER14_CH0_ON ⁽⁵⁾

Pin Name	Pins	Pin Type ⁽¹⁾	I/O Level ⁽²⁾	Functions description
				Additional: ADC_IN1, CMP_IP
PA2	8	I/O		Default: PA2 Alternate: USART0_TX ⁽³⁾ , USART1_TX ⁽⁴⁾ , TIMER14_CH0 ⁽⁵⁾ Additional: ADC_IN2, CMP_IM7
PA3	9	I/O		Default: PA3 Alternate: USART0_RX ⁽³⁾ , USART1_RX ⁽⁴⁾ , TIMER14_CH1 ⁽⁵⁾ Additional: ADC_IN3
PA4	10	I/O		Default: PA4 Alternate: SPI0_NSS, I2S0_WS, USART0_CK ⁽³⁾ , USART1_CK ⁽⁴⁾ , TIMER13_CH0, SPI1_NSS ⁽⁵⁾ Additional: ADC_IN4, CMP_IM4
PA5	11	I/O		Default: PA5 Alternate: SPI0_SCK, I2S0_CK Additional: ADC_IN5, CMP_IM5
PA6	12	I/O		Default: PA6 Alternate: SPI0_MISO, I2S0_MCK, TIMER2_CH0, TIMER0_BRKIN, TIMER15_CH0, EVENTOUT, CMP_OUT Additional: ADC_IN6
PA7	13	I/O		Default: PA7 Alternate: SPI0_MOSI, I2S0_SD, TIMER2_CH1, TIMER13_CH0, TIMER0_CH0_ON, TIMER16_CH0, EVENTOUT Additional: ADC_IN7
PB0	14	I/O		Default: PB0 Alternate: TIMER2_CH2, TIMER0_CH1_ON, USART1_RX ⁽⁴⁾ , EVENTOUT Additional: ADC_IN8
PB1	15	I/O		Default: PB1 Alternate: TIMER2_CH3, TIMER13_CH0, TIMER0_CH2_ON, SPI1_SCK ⁽⁵⁾ Additional: ADC_IN9
PB2	16	I/O	5VT	Default: PB2 Alternate: TIMER2_ETI
V _{DD}	17	P		Default: V _{DD}
PA8	18	I/O	5VT	Default: PA8 Alternate: USART0_CK, TIMER0_CH0, CK_OUT, USART1_TX ⁽⁴⁾ , EVENTOUT
PA9	19	I/O	5VT	Default: PA9 Alternate: USART0_TX, TIMER0_CH1, TIMER14_BRKIN ⁽⁵⁾ , I2C0_SCL, CK_OUT
PA10	20	I/O	5VT	Default: PA10 Alternate: USART0_RX, TIMER0_CH2, TIMER16_BRKIN, I2C0_SDA

Pin Name	Pins	Pin Type ⁽¹⁾	I/O Level ⁽²⁾	Functions description
PA11	21	I/O	5VT	Default: PA11 Alternate: USART0_CTS, TIMER0_CH3, CMP_OUT, EVENTOUT, SPI1_IO2 ⁽⁵⁾ , I2C0_SMBA, I2C1_SCL ⁽⁵⁾
PA12	22	I/O	5VT	Default: PA12 Alternate: USART0_RTS, TIMER0_ETI, EVENTOUT, SPI1_IO3 ⁽⁵⁾ , I2C0_TXFRAME, I2C1_SDA ⁽⁵⁾
PA13	23	I/O	5VT	Default: PA13 Alternate: SWDIO, IFRP_OUT, SPI1_MISO ⁽⁵⁾
PA14	24	I/O	5VT	Default: PA14 Alternate: USART0_TX ⁽³⁾ , USART1_TX ⁽⁴⁾ , SWCLK, SPI1_MOSI ⁽⁵⁾
PA15	25	I/O	5VT	Default: PA15 Alternate: SPI0_NSS, I2S0_WS, USART0_RX ⁽³⁾ , USART1_RX ⁽⁴⁾ , SPI1_NSS ⁽⁵⁾ , EVENTOUT
PB3	26	I/O	5VT	Default: PB3 Alternate: SPI0_SCK, I2S0_CK, EVENTOUT
PB4	27	I/O	5VT	Default: PB4 Alternate: SPI0_MISO, I2S0_MCK, TIMER2_CH0, EVENTOUT, I2C0_TXFRAME, TIMER16_BRKIN
PB5	28	I/O	5VT	Default: PB5 Alternate: SPI0_MOSI, I2S0_SD, I2C0_SMBA, TIMER15_BRKIN, TIMER2_CH1 Additional: WKUP5
PB6	29	I/O	5VT	Default: PB6 Alternate: I2C0_SCL, USART0_TX, TIMER15_CH0_ON
PB7	30	I/O	5VT	Default: PB7 Alternate: I2C0_SDA, USART0_RX, TIMER16_CH0_ON
BOOT0	31	I		Default: BOOT0
PB8	32	I/O	5VT	Default: PB8 Alternate: I2C0_SCL, TIMER15_CH0

Notes:

- (1) Type: I = input, O = output, P = power.
- (2) I/O Level: 5VT = 5 V tolerant.
- (3) Functions are available on GD32E230K4 devices only.
- (4) Functions are available on GD32E230K8/6 devices.
- (5) Functions are available on GD32E230K8 devices only.

2.6.4 GD32E230Gx QFN28 pin definitions

Table 2-7. GD32E230Gx QFN28 pin definitions

Pin Name	Pins	Pin Type ⁽¹⁾	I/O Level ⁽²⁾	Functions description
BOOT0	1	I		Default: BOOT0
PF0-OSCIN	2	I/O	5VT	Default: PF0

Pin Name	Pins	Pin Type ⁽¹⁾	I/O Level ⁽²⁾	Functions description
				Alternate: I2C0_SDA Additional: OSCIN
PF1-OSCOUT	3	I/O	5VT	Default: PF1 Alternate: I2C0_SCL Additional: OSCOUT
NRST	4	I/O		Default: NRST
V _{DDA}	5	P		Default: V _{DDA}
PA0-WKUP	6	I/O		Default: PA0 Alternate: USART0_CTS ⁽³⁾ , USART1_CTS ⁽⁴⁾ , CMP_OUT, I2C1_SCL ⁽⁵⁾ Additional: ADC_IN0, CMP_IM6, RTC_TAMP1, WKUP0
PA1	7	I/O		Default: PA1 Alternate: USART0_RTS ⁽³⁾ , USART1_RTS ⁽⁴⁾ , I2C1_SDA ⁽⁵⁾ , EVENTOUT, TIMER14_CH0_ON ⁽⁵⁾ Additional: ADC_IN1, CMP_IP
PA2	8	I/O		Default: PA2 Alternate: USART0_TX ⁽³⁾ , USART1_TX ⁽⁴⁾ , TIMER14_CH0 ⁽⁵⁾ Additional: ADC_IN2, CMP_IM7
PA3	9	I/O		Default: PA3 Alternate: USART0_RX ⁽³⁾ , USART1_RX ⁽⁴⁾ , TIMER14_CH1 ⁽⁵⁾ Additional: ADC_IN3
PA4	10	I/O		Default: PA4 Alternate: SPI0_NSS, I2S0_WS, USART0_CK ⁽³⁾ , USART1_CK ⁽⁴⁾ , TIMER13_CH0, SPI1_NSS ⁽⁵⁾ Additional: ADC_IN4, CMP_IM4
PA5	11	I/O		Default: PA5 Alternate: SPI0_SCK, I2S0_CK Additional: ADC_IN5, CMP_IM5
PA6	12	I/O		Default: PA6 Alternate: SPI0_MISO, I2S0_MCK, TIMER2_CH0, TIMER0_BRKIN, TIMER15_CH0, EVENTOUT, CMP_OUT Additional: ADC_IN6
PA7	13	I/O		Default: PA7 Alternate: SPI0_MOSI, I2S0_SD, TIMER2_CH1, TIMER13_CH0, TIMER0_CH0_ON, TIMER16_CH0, EVENTOUT Additional: ADC_IN7
PB0	14	I/O		Default: PB0 Alternate: TIMER2_CH2, TIMER0_CH1_ON, USART1_RX ⁽⁴⁾ , EVENTOUT Additional: ADC_IN8
PB1	15	I/O		Default: PB1 Alternate: TIMER2_CH3, TIMER13_CH0,

Pin Name	Pins	Pin Type ⁽¹⁾	I/O Level ⁽²⁾	Functions description
				TIMER0_CH2_ON, SPI1_SCK ⁽⁵⁾ Additional: ADC_IN9
V _{SS}	16	P		Default: V _{SS}
V _{DD}	17	P		Default: V _{DD}
PA8	18	I/O	5VT	Default: PA8 Alternate: USART0_CK, TIMER0_CH0, CK_OUT, USART1_TX ⁽⁴⁾ , EVENTOUT
PA9 ⁽⁶⁾	19	I/O	5VT	Default: PA9 Alternate: USART0_TX, TIMER0_CH1, TIMER14_BRKIN ⁽⁵⁾ , I2C0_SCL, CK_OUT
PA10 ⁽⁶⁾	20	I/O	5VT	Default: PA10 Alternate: USART0_RX, TIMER0_CH2, TIMER16_BRKIN, I2C0_SDA
PA13	21	I/O	5VT	Default: PA13 Alternate: SWDIO, IFRP_OUT, SPI1_MISO ⁽⁵⁾
PA14	22	I/O	5VT	Default: PA14 Alternate: USART0_TX ⁽³⁾ , USART1_TX ⁽⁴⁾ , SWCLK, SPI1_MOSI ⁽⁵⁾
PA15	23	I/O	5VT	Default: PA15 Alternate: SPI0_NSS, I2S0_WS, USART0_RX ⁽³⁾ , USART1_RX ⁽⁴⁾ , SPI1_NSS ⁽⁵⁾ , EVENTOUT
PB3	24	I/O	5VT	Default: PB3 Alternate: SPI0_SCK, I2S0_CK, EVENTOUT
PB4	25	I/O	5VT	Default: PB4 Alternate: SPI0_MISO, I2S0_MCK, TIMER2_CH0, EVENTOUT, I2C0_TXFRAME, TIMER16_BRKIN
PB5	26	I/O	5VT	Default: PB5 Alternate: SPI0_MOSI, I2S0_SD, I2C0_SMBA, TIMER15_BRKIN, TIMER2_CH1 Additional: WKUP5
PB6	27	I/O	5VT	Default: PB6 Alternate: I2C0_SCL, USART0_TX, TIMER15_CH0_ON
PB7	28	I/O	5VT	Default: PB7 Alternate: I2C0_SDA, USART0_RX, TIMER16_CH0_ON

Notes:

- (1) Type: I = input, O = output, P = power.
- (2) I/O Level: 5VT = 5 V tolerant.
- (3) Functions are available on GD32E230G4 devices only.
- (4) Functions are available on GD32E230G8/6 devices.
- (5) Functions are available on GD32E230G8 devices only.
- (6) Pin pair PA11/PA12 can be remapped instead of pin pair PA9/PA10 using SYSCFG_CFG0 register. [Table 2-9. Port A alternate functions summary](#) shows PA11/PA12 remap.

2.6.5 GD32E230Fx TSSOP20 pin definitions
Table 2-8. GD32E230Fx TSSOP20 pin definitions

Pin Name	Pins	Pin Type ⁽¹⁾	I/O Level ⁽²⁾	Functions description
PF0-OSCIN	2	I/O	5VT	Default: PF0 Alternate: I2C0_SDA Additional: OSCIN
PF1-OSCOU	3	I/O	5VT	Default: PF1 Alternate: I2C0_SCL Additional: OSCOUT
NRST	4	I/O		Default: NRST
V _{DDA}	5	P		Default: V _{DDA}
PA0-WKUP	6	I/O		Default: PA0 Alternate: USART0_CTS ⁽³⁾ , USART1_CTS ⁽⁴⁾ , CMP_OUT, I2C1_SCL ⁽⁵⁾ Additional: ADC_IN0, CMP_IM6, RTC_TAMP1, WKUP0
PA1	7	I/O		Default: PA1 Alternate: USART0_RTS ⁽³⁾ , USART1_RTS ⁽⁴⁾ , I2C1_SDA ⁽⁵⁾ , EVENTOUT Additional: ADC_IN1, CMP_IP
PA2	8	I/O		Default: PA2 Alternate: USART0_TX ⁽³⁾ , USART1_TX ⁽⁴⁾ Additional: ADC_IN2, CMP_IM7
PA3	9	I/O		Default: PA3 Alternate: USART0_RX ⁽³⁾ , USART1_RX ⁽⁴⁾ Additional: ADC_IN3
PA4	10	I/O		Default: PA4 Alternate: SPI0_NSS, I2S0_WS, USART0_CK ⁽³⁾ , USART1_CK ⁽⁴⁾ , TIMER13_CH0, SPI1_NSS ⁽⁵⁾ Additional: ADC_IN4, CMP_IM4
PA5	11	I/O		Default: PA5 Alternate: SPI0_SCK, I2S0_CK Additional: ADC_IN5, CMP_IM5
PA6	12	I/O		Default: PA6 Alternate: SPI0_MISO, I2S0_MCK, TIMER2_CH0, TIMER0_BRKIN, TIMER15_CH0, EVENTOUT, CMP_OUT Additional: ADC_IN6
PA7	13	I/O		Default: PA7 Alternate: SPI0_MOSI, I2S0_SD, TIMER2_CH1, TIMER13_CH0, TIMER0_CH0_ON, TIMER16_CH0, EVENTOUT Additional: ADC_IN7
PB1	14	I/O		Default: PB1 Alternate: TIMER2_CH3, TIMER13_CH0, TIMER0_CH2_ON, SPI1_SCK ⁽⁵⁾

Pin Name	Pins	Pin Type ⁽¹⁾	I/O Level ⁽²⁾	Functions description
				Additional: ADC_IN9
V _{SS}	15	P		Default: V _{SS}
V _{DD}	16	P		Default: V _{DD}
PA9 ⁽⁶⁾	17	I/O	5VT	Default: PA9 Alternate: USART0_TX, TIMER0_CH1, I2C0_SCL, CK_OUT
PA10 ⁽⁶⁾	18	I/O	5VT	Default: PA10 Alternate: USART0_RX, TIMER0_CH2, TIMER16_BRKIN, I2C0_SDA
PA13	19	I/O	5VT	Default: PA13 Alternate: SWDIO, IFRP_OUT, SPI1_MISO ⁽⁵⁾
PA14	20	I/O	5VT	Default: PA14 Alternate: USART0_TX ⁽³⁾ , USART1_TX ⁽⁴⁾ , SWCLK, SPI1_MOSI ⁽⁵⁾
BOOT0	1	I		Default: BOOT0

Notes:

- (1) Type: I = input, O = output, P = power.
- (2) I/O Level: 5VT = 5 V tolerant.
- (3) Functions are available on GD32E230F4 devices only.
- (4) Functions are available on GD32E230F8/6 devices.
- (5) Functions are available on GD32E230F8 devices only.
- (6) Pin pair PA11/PA12 can be remapped instead of pin pair PA9/PA10 using SYSCFG_CFG0 register. [Table 2-9. Port A alternate functions summary](#) shows PA11/PA12 remap.

2.6.6 GD32E230xx pin alternate functions

Table 2-9. Port A alternate functions summary

Pin Name	AF0	AF1	AF2	AF3	AF4	AF5	AF6	AF7
PA0		USART0_CTS ⁽¹⁾ /USART1_CTS ⁽²⁾			I2C1_SCL ⁽³⁾			CMP_OUT
PA1	EVENTOUT	USART0_RTS ⁽¹⁾ /USART1_RTS ⁽²⁾			I2C1_SDA ⁽³⁾	TIMER14_CH0_ON ⁽³⁾		
PA2	TIMER14_CH0 ⁽³⁾	USART0_TX ⁽¹⁾ USART1_TX ⁽²⁾						
PA3	TIMER14_CH1 ⁽³⁾	USART0_RX ⁽¹⁾ USART1_RX ⁽²⁾						
PA4	SPI0_NSS /I2S0_WS	USART0_CK ⁽¹⁾ USART1_CK ⁽²⁾			TIMER13_CH0		SPI1_NSS ⁽³⁾	
PA5	SPI0_SCK /I2S0_CK							
PA6	SPI0_MISO /I2S0_MCK	TIMER2_CH0	TIMER0_BRKIN			TIMER15_CH0	EVENTOUT	CMP_OUT
PA7	SPI0_MOSI /I2S0_SD	TIMER2_CH1	TIMER0_CH0_ON		TIMER13_CH0	TIMER16_CH0	EVENTOUT	
PA8	CK_OUT	USART0_CK	TIMER0_CH0	EVENTOUT	USART1_TX ⁽²⁾			
PA9	TIMER14_BRKIN ⁽³⁾	USART0_TX	TIMER0_CH1		I2C0_SCL			
PA10	TIMER16_BRKIN	USART0_RX	TIMER0_CH2		I2C0_SDA			
PA11	EVENTOUT	USART0_CTS	TIMER0_CH3		I2C0_SMB_A	I2C1_SCL ⁽³⁾	SPI1_I/O2 ⁽³⁾	CMP_OUT
PA12	EVENTOUT	USART0_RTS	TIMER0_ETI		I2C0_TXFRAME	I2C1_SDA ⁽³⁾	SPI1_I/O3 ⁽³⁾	
PA13	SWDIO	IFRP_OUT					SPI1_MISO ⁽³⁾	
PA14	SWCLK	USART0_TX ⁽¹⁾ USART1_TX ⁽²⁾					SPI1_MOSI ⁽³⁾	
PA15	SPI0_NSS /I2S0_WS	USART0_RX ⁽¹⁾ USART1_RX ⁽²⁾		EVENTOUT			SPI1_NSS ⁽³⁾	

Table 2-10. Port B alternate functions summary

Pin Name	AF0	AF1	AF2	AF3	AF4	AF5	AF6	AF7
PB0	EVENTOUT	TIMER2_CH2	TIMER0_CH1_ON		USART1_RX ⁽²⁾			
PB1	TIMER13_CH0	TIMER2_CH3	TIMER0_CH2_ON				SPI1_SCK ⁽³⁾	
PB2			TIMER2_ETI					
PB3	SPI0_SCK/I2S0_CK	EVENTOUT						
PB4	SPI0_MISO/I2S0_MCK	TIMER2_CH0	EVENTOUT		I2C0_TXFRAME		TIMER16_BRKIN	
PB5	SPI0_MOSI/I2S0_SD	TIMER2_CH1	TIMER15_BRKIN	I2C0_SMBA				
PB6	USART0_TX	I2C0_SCL	TIMER15_CH0_ON					
PB7	USART0_RX	I2C0_SDA	TIMER16_CH0_ON					
PB8		I2C0_SCL	TIMER15_CH0					
PB9	IFRP_OUT	I2C0_SDA	TIMER16_CH0	EVENTOUT		I2S0_MCK		SPI1_NSS ⁽³⁾
PB10		I2C0_SCL ^{(1)/I2C1_SCL⁽³⁾}					SPI1_IO2 ⁽³⁾	SPI1_SCK ⁽³⁾
PB11	EVENTOUT	I2C0_SDA ^{(1)/I2C1_SDA⁽³⁾}					SPI1_IO3 ⁽³⁾	
PB12	SPI0_NSS ⁽¹⁾ /SPI1_NSS ⁽³⁾	EVENTOUT	TIMER0_BRKIN		I2C1_SMBA ⁽³⁾			
PB13	SPI0_SCK ⁽¹⁾ /SPI1_SCK ⁽³⁾	I2C1_TXFRAME ⁽³⁾	TIMER0_CH0_ON			I2C1_SCL ⁽³⁾		
PB14	SPI0_MISO ⁽¹⁾ /SPI1_MISO ⁽³⁾	TIMER14_CH0 ⁽³⁾	TIMER0_CH1_ON			I2C1_SDA ⁽³⁾		
PB15	SPI0_MOSI ⁽¹⁾ /SPI1_MOSI ⁽³⁾	TIMER14_CH1 ⁽³⁾	TIMER0_CH2_ON	TIMER14_CH0_ON ⁽³⁾				

Table 2-11. Port F alternate functions summary

Pin Name	AF0	AF1	AF2	AF3	AF4	AF5	AF6
PF0		I2C0_SDA					
PF1		I2C0_SCL					
PF6	I2C0_SCL ⁽¹⁾ I2C1_SCL ⁽³⁾						
PF7	I2C0_SDA ⁽¹⁾ I2C1_SDA ⁽³⁾						

Notes:

- (1) Functions are available on GD32E230x4 devices only.
- (2) Functions are available on GD32E230x8/6 devices.
- (3) Functions are available on GD32E230x8 devices only.

3 Functional description

3.1 ARM® Cortex®-M23 core

The Cortex-M23 processor is an energy-efficient processor with a very low gate count. It is intended to be used for microcontroller and deeply embedded applications that require an area-optimized processor. The processor is highly configurable enabling a wide range of implementations from those requiring memory protection and powerful trace technology to cost sensitive devices requiring minimal area, while delivering outstanding computational performance and an advanced system response to interrupts.

32-bit ARM® Cortex®-M23 processor core

- Up to 72 MHz operation frequency
- Single-cycle multiplication and hardware divider
- Ultra-low power, energy-efficient operation
- Excellent code density
- Integrated Nested Vectored Interrupt Controller (NVIC)
- 24-bit SysTick timer

The Cortex®-M23 processor is based on the ARMv8-M architecture and supports both Thumb and Thumb-2 instruction sets. Some system peripherals listed below are also provided by Cortex®-M23:

- Internal Bus Matrix connected with AHB master, Serial Wire Debug Port and Single-cycle IO port
- Nested Vectored Interrupt Controller (NVIC)
- Breakpoint Unit(BPU)
- Data Watchpoint and Trace (DWT)
- Serial Wire JTAG Debug Port (SWJ-DP)

3.2 Embedded memory

- Up to 64 Kbytes of Flash memory
- Up to 8 Kbytes of SRAM with hardware parity checking

The ARM® Cortex®-M23 processor is structured in Harvard architecture which can use separate buses to fetch instructions and load/store data. 64 Kbytes of inner Flash and 8 Kbytes of inner SRAM at most is available for storing programs and data, both accessed (R/W) at CPU clock speed with 0~2 wait states. [Table 2-3. GD32E230xx memory map](#) shows the memory map of the GD32E230xx series of devices, including code, SRAM, peripheral, and other pre-defined regions.

3.3 Clock, reset and supply management

- Internal 8 MHz factory-trimmed RC and external 4 to 32 MHz crystal oscillator
- Internal 28 MHz RC oscillator
- Internal 40 KHz RC calibrated oscillator and external 32.768 KHz crystal oscillator
- Integrated system clock PLL
- 1.8 to 3.6 V application supply and I/Os
- Supply Supervisor: POR (Power On Reset), PDR (Power Down Reset), and low voltage detector (LVD)

The Clock Control Unit (CCU) provides a range of oscillator and clock functions. These include speed internal RC oscillator and external crystal oscillator, high speed and low speed two types. Several prescalers allow the frequency configuration of the AHB and two APB domains. The maximum frequency of the AHB, APB2 and APB1 domains is 72 MHz/72 MHz/72 MHz. See [Figure 2-7. GD32E230xx clock tree](#) for details on the clock tree.

The Reset Control Unit (RCU) controls three kinds of reset: system reset resets the processor core and peripheral IP components. Power-on reset (POR) and power-down reset (PDR) are always active, and ensures proper operation starting from 2.6 V and down to 1.8V. The device remains in reset mode when V_{DD} is below a specified threshold. The embedded low voltage detector (LVD) monitors the power supply, compares it to the voltage threshold and generates an interrupt as a warning message for leading the MCU into security.

Power supply schemes:

- V_{DD} range: 1.8 to 3.6 V, external power supply for I/Os and the internal regulator. Provided externally through V_{DD} pins.
- V_{SSA} , V_{DDA} range: 1.8 to 3.6 V, external analog power supplies for ADC, reset blocks, RCs and PLL. V_{DDA} and V_{SSA} must be connected to V_{DD} and V_{SS} , respectively.
- V_{BAK} range: 1.8 to 3.6 V, power supply for RTC, external clock 32 KHz oscillator and backup registers (through power switch) when V_{DD} is not present.

3.4 Boot modes

At startup, boot pins are used to select one of three boot options:

- Boot from main Flash memory (default)
- Boot from system memory
- Boot from on-chip SRAM

In default condition, boot from main Flash memory is selected. The boot loader is located in the internal boot ROM memory (system memory). It is used to reprogram the Flash memory by using USART0 (PA9 and PA10) or USART1 (PA14 and PA15).

3.5 Power saving modes

The MCU supports three kinds of power saving modes to achieve even lower power consumption. They are sleep mode, deep-sleep mode, and standby mode. These operating modes reduce the power consumption and allow the application to achieve the best balance between the CPU operating time, speed and power consumption.

■ Sleep mode

In sleep mode, only the clock of CPU core is off. All peripherals continue to operate and any interrupt/event can wake up the system.

■ Deep-sleep mode

In deep-sleep mode, all clocks in the 1.2V domain are off, and all of the high speed crystal oscillator (IRC8M, HXTAL) and PLL are disabled. Only the contents of SRAM and registers are retained. Any interrupt or wakeup event from EXTI lines can wake up the system from the deep-sleep mode including the 16 external lines, the RTC alarm, RTC tamper and timestamp, CMP output, LVD output and USART wakeup. When exiting the deep-sleep mode, the IRC8M is selected as the system clock.

■ Standby mode

In standby mode, the whole 1.2V domain is power off, the LDO is shut down, and all of IRC8M, HXTAL and PLL are disabled. The contents of SRAM and registers (except backup registers) are lost. There are four wakeup sources for the standby mode, including the external reset from NRST pin, the RTC alarm, the FWDGT reset, and the rising edge on WKUP pin.

3.6 Analog to digital converter (ADC)

- 12-bit SAR ADC's conversion rate is up to 2 MSPS
- 12-bit, 10-bit, 8-bit or 6-bit configurable resolution
- Hardware oversampling ratio adjustable from 2 to 256x improves resolution to 16-bit
- Input voltage range: V_{SSA} to V_{DDA}
- Temperature sensor

One 12-bit 2 MSPS multi-channel ADC is integrated in the device. It has a total of 12 multiplexed channels: up to 10 external channels, 1 channel for internal temperature sensor (V_{SENSE}) and 1 channel for internal reference voltage (V_{REFINT}). The input voltage range is between V_{SSA} and V_{DDA} . An on-chip hardware oversampling scheme improves performance while off-loading the related computational burden from the CPU. An analog watchdog block can be used to detect the channels, which are required to remain within a specific threshold window. A configurable channel management block can be used to perform conversions in single, continuous, scan or discontinuous mode to support more advanced use.

The ADC can be triggered from the events generated by the general level 0 timers (TIMERx) and the advanced timer (TIMER0) with internal connection. The temperature sensor can be used to generate a voltage that varies linearly with temperature. It is internally connected to

the ADC_IN16 input channel which is used to convert the sensor output voltage in a digital value.

3.7 DMA

- 5 channels DMA controller
- Peripherals supported: Timers, ADC, SPIs, I2Cs, USARTs and I2S

The flexible general-purpose DMA controllers provide a hardware method of transferring data between peripherals and/or memory without intervention from the CPU, thereby freeing up bandwidth for other system functions. Three types of access method are supported: peripheral to memory, memory to peripheral, memory to memory.

Each channel is connected to fixed hardware DMA requests. The priorities of DMA channel requests are determined by software configuration and hardware channel number. Transfer size of source and destination are independent and configurable.

3.8 General-purpose inputs/outputs (GPIOs)

- Up to 39 fast GPIOs, all mappable on 16 external interrupt lines
- Analog input/output configurable
- Alternate function input/output configurable

There are up to 39 general purpose I/O pins (GPIO) in GD32E230xx, named PA0 ~ PA15 and PB0 ~ PB15, PC13 ~ PC15, PF0 ~ PF1, PF6 ~ PF7 to implement logic input/output functions. Each of the GPIO ports has related control and configuration registers to satisfy the requirements of specific applications. The external interrupts on the GPIO pins of the device have related control and configuration registers in the Interrupt/event controller (EXTI). The GPIO ports are pin-shared with other alternative functions (AFs) to obtain maximum flexibility on the package pins. Each of the GPIO pins can be configured by software as output (push-pull open-drain or analog), as input (with or without pull-up or pull-down) or as peripheral alternate function. Most of the GPIO pins are shared with digital or analog alternate functions. All GPIOs are high-current capable except for analog inputs.

3.9 Timers and PWM generation

- One 16-bit advanced timer (TIMER0), up to five 16-bit general timers (TIMER2, TIMER13 ~ TIMER16), and one 16-bit basic timer (TIMER5)
- Up to 4 independent channels of PWM, output compare or input capture for each general timer and external trigger input
- 16-bit, motor control PWM advanced timer with programmable dead-time generation for output match
- Encoder interface controller with two inputs using quadrature decoder

- 24-bit SysTick timer down counter
- 2 watchdog timers (free watchdog timer and window watchdog timer)

The advanced timer (TIMER0) can be used as a three-phase PWM multiplexed on 6 channels. It has complementary PWM outputs with programmable dead-time generation. It can also be used as a complete general timer. The 4 independent channels can be used for input capture, output compare, PWM generation (edge- or center- aligned counting modes) and single pulse mode output. If configured as a general 16-bit timer, it has the same functions as the TIMEx timer. It can be synchronized with external signals or to interconnect with other general timers together which have the same architecture and features.

The general timer can be used for a variety of purposes including general time, input signal pulse width measurement or output waveform generation such as a single pulse generation or PWM output, up to 4 independent channels for input capture/output compare. TIMER2 is based on a 16-bit auto-reload up/down counter and a 16-bit prescaler. TIMER13 ~ TIMER16 is based on a 16-bit auto-reload up counter and a 16-bit prescaler. The general timer also supports an encoder interface with two inputs using quadrature decoder.

The basic timer, known as TIMER5 can also be used as a simple 16-bit time base.

The GD32E230xx have two watchdog peripherals, free watchdog and window watchdog. They offer a combination of high safety level, flexibility of use and timing accuracy.

The free watchdog timer includes a 12-bit down-counting counter and an 8-bit prescaler. It is clocked from an independent 40 KHz internal RC and as it operates independently of the main clock, it can operate in deep-sleep and standby modes. It can be used either as a watchdog to reset the device when a problem occurs, or as a free-running timer for application timeout management.

The window watchdog is based on a 7-bit down counter that can be set as free-running. It can be used as a watchdog to reset the device when a problem occurs. It is clocked from the main clock. It has an early wakeup interrupt capability and the counter can be frozen in debug mode.

The SysTick timer is dedicated for OS, but could also be used as a standard down counter. The features are shown below:

- A 24-bit down counter
- Auto reload capability
- Maskable system interrupt generation when the counter reaches 0
- Programmable clock source

3.10 Real time clock (RTC)

- Independent binary-coded decimal (BCD) format timer/counter with five 32-bit backup registers.
- Calendar with subsecond, second, minute, hour, week day, date, year and month automatically correction

- Alarm function with wake up from deep-sleep and standby mode capability
- On-the-fly correction for synchronization with master clock. Digital calibration with 0.954 ppm resolution for compensation of quartz crystal inaccuracy.

The real time clock is an independent timer which provides a set of continuously running counters in backup registers to provide a real calendar function, and provides an alarm interrupt or an expected interrupt. It is not reset by a system or power reset, or when the device wakes up from standby mode. In the RTC unit, there are two prescalers used for implementing the calendar and other functions. One prescaler is a 7-bit asynchronous prescaler and the other is a 15-bit synchronous prescaler.

3.11 Inter-integrated circuit (I2C)

- Up to two I2C bus interfaces can support both master and slave mode with a frequency up to 1 MHz (Fast mode plus)
- Provide arbitration function, optional PEC (packet error checking) generation and checking
- Supports 7-bit and 10-bit addressing mode and general call addressing mode
- Supports SAM_V mode

The I2C interface is an internal circuit allowing communication with an external I2C interface which is an industry standard two line serial interface used for connection to external hardware. These two serial lines are known as a serial data line (SDA) and a serial clock line (SCL). The I2C module provides different data transfer rates: up to 100 KHz in standard mode, up to 400 KHz in the fast mode and up to 1 MHz in the fast mode plus. The I2C module also has an arbitration detect function to prevent the situation where more than one master attempts to transmit data to the I2C bus at the same time. A CRC-8 calculator is also provided in I2C interface to perform packet error checking for I2C data.

3.12 Serial peripheral interface (SPI)

- Up to two SPI interfaces with a frequency of up to 18 MHz
- Support both master and slave mode
- Hardware CRC calculation and transmit automatic CRC error checking
- Separate transmit and receive 32-bit FIFO with DMA capability (only in SPI1)
- Data frame size can be 4 to 16 bits (only in SPI1)
- Quad-SPI configuration available in master mode (only in SPI1)

The SPI interface uses 4 pins, among which are the serial data input and output lines (MISO & MOSI), the clock line (SCK) and the slave select line (NSS). Both SPIs can be served by the DMA controller. The SPI interface may be used for a variety of purposes, including simplex synchronous transfers on two lines with a possible bidirectional data line or reliable communication using CRC checking. Specially, SPI1 has separate transmit and receive 32-

bit FIFO with DMA capability and its data frame size can be 4 to 16 bits. Quad-SPI master mode is also supported in SPI1.

3.13 Universal synchronous asynchronous receiver transmitter (USART)

- Up to two USARTs with operating frequency up to 4.5 Mbits/s
- Supports both asynchronous and clocked synchronous serial communication modes
- IrDA SIR encoder and decoder support
- LIN break generation and detection
- ISO 7816-3 compliant smart card interface

The USART (USART0, USART1) are used to translate data between parallel and serial interfaces, provides a flexible full duplex data exchange using synchronous or asynchronous transfer. It is also commonly used for RS-232 standard communication. The USART includes a programmable baud rate generator which is capable of dividing the system clock to produce a dedicated clock for the USART transmitter and receiver. The USART also supports DMA function for high speed data communication.

3.14 Inter-IC sound (I2S)

- One I2S bus Interfaces with sampling frequency from 8 KHz to 192 KHz, multiplexed with SPI0
- Support either master or slave mode

The Inter-IC sound (I2S) bus provides a standard communication interface for digital audio applications by 3-wire serial lines. GD32E230xx contain an I2S-bus interface that can be operated with 16/32 bit resolution in master or slave mode, pin multiplexed with SPI0. The audio sampling frequency from 8 KHz to 192 KHz is supported with less than 0.5% accuracy error.

3.15 Comparators (CMP)

- One fast rail-to-rail low-power comparators with software configurable
- Programmable reference voltage (internal or external I/O)

One Comparator (CMP) is implemented within the devices. It can wake up from deep-sleep mode to generate interrupts and breaks for the timers and also can be combined as a window comparator. The internal voltage reference is also connected to ADC_IN17 input channel of the ADC.

3.16 Debug mode

- Serial wire JTAG debug port (SWJ-DP)

The ARM® SWJ-DP Interface is embedded and is a combined JTAG and serial wire debug port that enables either a serial wire debug or a JTAG probe to be connected to the target.

3.17 Package and operation temperature

- LQFP48 (GD32E230CxTx), LQFP32 (GD32E230KxTx), QFN32 (GD32E230KxUx), QFN28 (GD32E230GxUx) and TSSOP20 (GD32E230FxPx).
- Operation temperature range: -40°C to +85°C (industrial level)

4 Electrical characteristics

4.1 Absolute maximum ratings

The maximum ratings are the limits to which the device can be subjected without permanently damaging the device. Note that the device is not guaranteed to operate properly at the maximum ratings. Exposure to the absolute maximum rating conditions for extended periods may affect device reliability.

Table 4-1. Absolute maximum ratings

Symbol	Parameter	Min	Max	Unit
V_{DD}	External voltage range ⁽¹⁾	$V_{SS} - 0.3$	$V_{SS} + 3.6$	V
V_{DDA}	External analog supply voltage	$V_{SSA} - 0.3$	$V_{SSA} + 3.6$	V
V_{IN}	Input voltage on 5V tolerant pin ⁽²⁾	$V_{SS} - 0.3$	$V_{DD} + 4.0$	V
	Input voltage on other I/O	$V_{SS} - 0.3$	4.0	V
$ \Delta V_{DDx} $	Variations between different V_{DD} power pins	—	50	mV
$ V_{SSx} - V_{SS} $	Variations between different ground pins	—	50	mV
I_{IO}	Maximum current for GPIO pins	—	25	mA
I_{INJ}	Injected current on 5V tolerant pin	—	-5/+0	mA
	Injected current on other I/O	—	±5	mA
$\sum I_{INJ}$	Injected current on all I/O ⁽³⁾	—	±25	mA
T_A	Operating temperature range	-40	+85	°C
T_{STG}	Storage temperature range	-55	+150	°C
T_J	Maximum junction temperature	—	125	°C

(1) All main power and ground pins should be connected to the external power supply in the permitted range.

(2) V_{IN} maximum value must be respected refer to [Table 4-1. Absolute maximum ratings](#) for the values of the maximum allowed injected current.

(3) When several inputs are submitted to a current injection, the maximum $\sum I_{INJ(PIN)}$ is the absolute sum of the positive and negative injected currents (instantaneous values).

4.2 Operating conditions characteristics

Table 4-2. DC operating conditions

Symbol	Parameter	Conditions	Min	Typ	Max	Unit
V_{DD}	Supply voltage	—	1.8	3.3	3.6	V
V_{DDA}	Analog supply voltage ADC not used	—	1.8	3.3	3.6	V
	Analog supply voltage ADC used		2.4	3.3	3.6	

Table 4-3. Clock frequency

Symbol	Parameter	Conditions	Min	Max	Unit
f_{HCLK}	AHB clock frequency	—	0	72	MHz
f_{APB1}	APB1 clock frequency	—	0	72	MHz
f_{APB2}	APB2 clock frequency	—	0	72	MHz

Table 4-4. Operating conditions at Power up/ Power down

Symbol	Parameter	Conditions	Min	Max	Unit
$t_{VDD}^{(1)}$	V_{DD} rise time rate	—	20	∞	us/V
	V_{DD} fall time rate		20	∞	

Table 4-5. Start-up timings of Operating conditions

Symbol	Parameter	Conditions	Typ	Unit
$t_{start-up}^{(1)}$	Start-up time	Clock source from HXTAL	432	μ s
		Clock source from IRC8M	76	

(1). After power-up, the start-up time is the time between NRST high level rising edge and the main function.

Table 4-6. Power saving mode wakeup timings characteristics

Symbol	Parameter	Typ	Unit
$t_{Sleep}^{(1)}$	Wakeup from Sleep mode	3.5	μ s
$t_{Deep-sleep}^{(1)}$	Wakeup from Deep-sleep mode (LDO On)	17.1	
	Wakeup from Deep-sleep mode (LDO in low power mode)	17.1	
$t_{Standby}^{(1)}$	Wakeup from Standby mode	77.5	

(1). Conditions: $V_{DD}=V_{DDA}=3.3V$, IRC8M=System clock=8MHz. The wakeup times are measured from the wakeup event to the point in which the application code reads the first instruction.

4.3 Power consumption

The power measurements specified in the tables represent that code with data executing from embedded Flash with the following specifications.

Table 4-7. Power consumption characteristics

Symbol	Parameter	Conditions	Min	Typ	Max	Unit
I_{DD}	Supply current (Run mode)	$V_{DD}=V_{DDA}=3.3V$, HXTAL=8MHz, System clock=72 MHz, All peripherals enabled	—	8.5	—	mA
		$V_{DD}=V_{DDA}=3.3V$, HXTAL=8MHz, System clock =72 MHz, All peripherals disabled	—	5.4	—	mA
		$V_{DD}=V_{DDA}=3.3V$, HXTAL=8MHz, System clock=48 MHz, All peripherals enabled	—	6.2	—	mA
		$V_{DD}=V_{DDA}=3.3V$, HXTAL=8MHz, System clock =48 MHz, All peripherals disabled	—	4.2	—	mA
		$V_{DD}=V_{DDA}=3.3V$, HXTAL=8MHz, System clock=36 MHz, All peripherals enabled	—	5.1	—	mA

Symbol	Parameter	Conditions	Min	Typ	Max	Unit
		$V_{DD}=V_{DDA}=3.3V$, HXTAL=8MHz, System clock =36 MHz, All peripherals disabled	---	3.6	---	mA
		$V_{DD}=V_{DDA}=3.3V$, HXTAL=8MHz, System clock=24 MHz, All peripherals enabled	—	4.0	—	mA
		$V_{DD}=V_{DDA}=3.3V$, HXTAL=8MHz, System clock =24 MHz, All peripherals disabled	—	2.9	—	mA
		$V_{DD}=V_{DDA}=3.3V$, HXTAL=8MHz, System clock=16 MHz, All peripherals enabled	---	3.2	---	mA
		$V_{DD}=V_{DDA}=3.3V$, HXTAL=8MHz, System clock =16 MHz, All peripherals disabled	—	2.5	—	mA
		$V_{DD}=V_{DDA}=3.3V$, HXTAL=8MHz, System clock=8 MHz, All peripherals enabled	—	2.4	—	mA
		$V_{DD}=V_{DDA}=3.3V$, HXTAL=8MHz, System clock =8 MHz, All peripherals disabled	---	2.1	---	mA
		$V_{DD}=V_{DDA}=3.3V$, HXTAL=8MHz, System clock=4 MHz, All peripherals enabled	—	0.8	—	mA
		$V_{DD}=V_{DDA}=3.3V$, HXTAL=8MHz, System clock =4 MHz, All peripherals disabled	—	0.6	—	mA
		$V_{DD}=V_{DDA}=3.3V$, HXTAL=8MHz, System clock=2 MHz, All peripherals enabled	---	0.6	---	mA
		$V_{DD}=V_{DDA}=3.3V$, HXTAL=8MHz, System clock =2 MHz, All peripherals disabled	—	0.5	—	mA
	Supply current (Sleep mode)	$V_{DD}=V_{DDA}=3.3V$, HXTAL=8MHz, CPU clock off, System clock =72 MHz, All peripherals enabled	—	7.4	—	mA
		$V_{DD}=V_{DDA}=3.3V$, HXTAL=8MHz, CPU clock off, System clock =72 MHz, All peripherals disabled	—	3.7	—	mA
		$V_{DD}=V_{DDA}=3.3V$, HXTAL=8MHz, CPU clock off, System clock =48 MHz, All peripherals enabled	---	5.5	---	mA
		$V_{DD}=V_{DDA}=3.3V$, HXTAL=8MHz, CPU clock off, System clock =48 MHz, All peripherals disabled	—	3.1	—	mA
		$V_{DD}=V_{DDA}=3.3V$, HXTAL=8MHz, CPU clock off, System clock =36 MHz, All peripherals enabled	—	4.5	—	mA
		$V_{DD}=V_{DDA}=3.3V$, HXTAL=8MHz, CPU clock off, System clock =36 MHz, All peripherals disabled	---	2.7	---	mA
		$V_{DD}=V_{DDA}=3.3V$, HXTAL=8MHz, CPU clock off, System clock =24 MHz, All peripherals enabled	—	3.6	—	mA

Symbol	Parameter	Conditions	Min	Typ	Max	Unit
		$V_{DD}=V_{DDA}=3.3V$, HXTAL=8MHz, CPU clock off, System clock =24 MHz, All peripherals disabled	—	2.4	—	mA
		$V_{DD}=V_{DDA}=3.3V$, HXTAL=8MHz, CPU clock off, System clock =16 MHz, All peripherals enabled	—	3.0	—	mA
		$V_{DD}=V_{DDA}=3.3V$, HXTAL=8MHz, CPU clock off, System clock =16 MHz, All peripherals disabled	—	2.1	—	mA
		$V_{DD}=V_{DDA}=3.3V$, HXTAL=8MHz, CPU clock off, System clock =8 MHz, All peripherals enabled	—	2.3	—	mA
		$V_{DD}=V_{DDA}=3.3V$, HXTAL=8MHz, CPU clock off, System clock =8 MHz, All peripherals disabled	—	1.9	—	mA
		$V_{DD}=V_{DDA}=3.3V$, HXTAL=8MHz, CPU clock off, System clock =4 MHz, All peripherals enabled	—	0.7	—	mA
		$V_{DD}=V_{DDA}=3.3V$, HXTAL=8MHz, CPU clock off, System clock =4 MHz, All peripherals disabled	—	0.5	—	mA
		$V_{DD}=V_{DDA}=3.3V$, HXTAL=8MHz, CPU clock off, System clock =2 MHz, All peripherals enabled	—	0.5	—	mA
		$V_{DD}=V_{DDA}=3.3V$, HXTAL=8MHz, CPU clock off, System clock =2 MHz, All peripherals disabled	—	0.4	—	mA
			Supply current (Deep-sleep mode)	$V_{DD}=V_{DDA}=3.3V$, Regulator in run mode, IRC40K off, RTC off, All GPIOs analog mode	—	25.5
$V_{DD}=V_{DDA}=3.3V$, Regulator in low power mode, IRC40K off, RTC off, All GPIOs analog mode	—			12.3	—	μA
	Supply current (Standby mode)	$V_{DD}=V_{DDA}=3.3V$, LXTAL off, IRC40K on, RTC on	—	3.8	—	μA
		$V_{DD}=V_{DDA}=3.3V$, LXTAL off, IRC40K on, RTC off	—	3.6	—	μA
		$V_{DD}=V_{DDA}=3.3V$, LXTAL off, IRC40K off, RTC off, VDDA Monitor on	—	3.1	—	μA
		$V_{DD}=V_{DDA}=3.3V$, LXTAL off, IRC40K off, RTC off, VDDA Monitor off	—	1.6	—	μA
$I_{LXTAL+RTC}$	LXTAL+RTC current	$V_{DD}=V_{DDA}=3.6V$, LXTAL on with external crystal, RTC on, Higher driving	—	1.43	—	μA
		$V_{DD}=V_{DDA}=3.3V$, LXTAL on with external	—	1.36	—	μA

Symbol	Parameter	Conditions	Min	Typ	Max	Unit
		crystal, RTC on, Higher driving				
		V _{DD} =V _{DDA} =2.5 V, LXTAL on with external crystal, RTC on, Higher driving	—	1.23	—	μA
		V _{DD} =V _{DDA} =1.8 V, LXTAL on with external crystal, RTC on, Higher driving	—	1.15	—	μA
		V _{DD} =V _{DDA} =3.6 V, LXTAL on with external crystal, RTC on, Medium High driving	—	1.13	—	μA
		V _{DD} =V _{DDA} =3.3 V, LXTAL on with external crystal, RTC on, Medium High driving	—	1.06	—	μA
		V _{DD} =V _{DDA} =2.5 V, LXTAL on with external crystal, RTC on, Medium High driving	—	0.95	—	μA
		V _{DD} =V _{DDA} =1.8 V, LXTAL on with external crystal, RTC on, Medium High driving	—	0.86	—	μA
		V _{DD} =V _{DDA} =3.6 V, LXTAL on with external crystal, RTC on, Medium Low driving	—	0.84	—	μA
		V _{DD} =V _{DDA} =3.3 V, LXTAL on with external crystal, RTC on, Medium Low driving	—	0.76	—	μA
		V _{DD} =V _{DDA} =2.5 V, LXTAL on with external crystal, RTC on, Medium Low driving	—	0.64	—	μA
		V _{DD} =V _{DDA} =1.8 V, LXTAL on with external crystal, RTC on, Medium Low driving	—	0.56	—	μA
		V _{DD} =V _{DDA} =3.6 V, LXTAL on with external crystal, RTC on, Low driving	—	0.74	—	μA
		V _{DD} =V _{DDA} =3.3 V, LXTAL on with external crystal, RTC on, Low driving	—	0.67	—	μA
		V _{DD} =V _{DDA} =2.5 V, LXTAL on with external crystal, RTC on, Low driving	—	0.56	—	μA
		V _{DD} =V _{DDA} =1.8 V, LXTAL on with external crystal, RTC on, Low driving	—	0.47	—	μA

Notes:

(1) When System Clock is less than 4MHz, an external source is used, and the HXTAL bypass function is needed, no PLL.

(2) When System Clock is greater than 8MHz, a crystal 8MHz is used, and the HXTAL bypass function is closed, using PLL.

(3) When analog peripheral blocks such as ADCs, HXTAL, LXTAL, IRC8M, or IRC40K are ON, an additional power consumption should be considered.

The power measurements specified in the tables represent that code with data executing from embedded Flash with the following specifications.

Table 4-8. Peripheral current consumption characteristics

Peripherals ⁽¹⁾		Typical consumption at 25°C (TYP)	Unit
APB1	PMU	1.44	mA

Peripherals ⁽¹⁾		Typical consumption at 25°C (TYP)	Unit
	I2C1	1.38	
	I2C0	1.38	
	USART1	1.34	
	SPI1	1.37	
	WWDGT	1.32	
	TIMER13	1.36	
	TIMER5	0.17	
	TIMER2	0.23	
APB2	DBG	1.3	
	TIMER16	1.42	
	TIMER15	1.42	
	TIMER14	1.49	
	USART0	1.63	
	SPI0	1.38	
	TIMER0	1.68	
	ADC ⁽²⁾	0.95	
SYSCFG & CMP ⁽³⁾		1.27	
AHB	GPIOF	1.31	
	GPIOC	1.31	
	GPIOB	1.34	
	GPIOA	1.34	
	CRC	0.16	
	DMA	0.15	

(1). Conditions: $V_{DD} = V_{DDA} = 3.3V$, IRC8M = 8MHz, system clock = $f_{HCLK} = 72MHz$, $f_{APB1} = f_{APB2} = f_{HCLK}$.

(2) .ADC: $f_{ADCCLK} = IRC28M$, ADCON bit set to 1 in ADC_CTL1.

(3). CMP: CMP enabled by setting CMPEN bit in CMP_CS. CMP mode set to High Speed.

4.4 EMC characteristics

EMS (electromagnetic susceptibility) includes ESD (Electrostatic discharge, positive and negative) and FTB (Burst of Fast Transient voltage, positive and negative) testing result is given in [Table 4-9. EMS characteristics](#), based on the EMS levels and classes compliant with IEC 61000 series standard.

Table 4-9. EMS characteristics

Symbol	Parameter	Conditions	Level/Class
V_{ESD}	Voltage applied to all device pins to induce a functional disturbance	$V_{DD} = 3.3 V$, $T_A = +25\text{ }^\circ\text{C}$, LQFP48, $f_{HCLK} = 72MHz$ conforms to IEC 61000-4-2	3A
V_{FTB}	Fast transient voltage burst applied to	$V_{DD} = 3.3 V$, $T_A = +25\text{ }^\circ\text{C}$,	4A

	induce a functional disturbance through 100 pF on V _{DD} and V _{SS} pins	LQFP48, f _{HCLK} = 72MHz conforms to IEC 61000-4-4	
--	---	--	--

EMI (Electromagnetic Interference) emission testing result is given in [Table 4-10. EMI characteristics](#), compliant with IEC 61967-2 standard which specifies the test board and the pin loading.

Table 4-10. EMI characteristics

Symbol	Parameter	Conditions	Tested frequency band	Conditions		Unit
				48M	72M	
S _{EMI}	Peak level	V _{DD} = 3.3 V, T _A = +25 °C, compliant with IEC 61967-2	0.1 to 2 MHz	—	—	dBμV
			2 to 30 MHz	—	—	
			30 to 130 MHz	—	—	
			130 MHz to 1GHz	—	—	

4.5 Power supply supervisor characteristics

Table 4-11. Power supply supervisor characteristics

Symbol	Parameter	Conditions	Min	Typ	Max	Unit
V_{LVD}	Low Voltage Detector Threshold	LVDT[2:0]=000, rising edge	—	2.11	—	V
		LVDT[2:0]=000, falling edge	—	2.01	—	V
		LVDT[2:0]=001, rising edge	—	2.25	—	V
		LVDT[2:0]=001, falling edge	—	2.16	—	V
		LVDT[2:0]=010, rising edge	—	2.39	—	V
		LVDT[2:0]=010, falling edge	—	2.29	—	V
		LVDT[2:0]=011, rising edge	—	2.52	—	V
		LVDT[2:0]=011, falling edge	—	2.43	—	V
		LVDT[2:0]=100, rising edge	—	2.66	—	V
		LVDT[2:0]=100, falling edge	—	2.57	—	V
		LVDT[2:0]=101, rising edge	—	2.80	—	V
		LVDT[2:0]=101, falling edge	—	2.71	—	V
		LVDT[2:0]=110, rising edge	—	2.95	—	V
		LVDT[2:0]=110, falling edge	—	2.84	—	V
LVDT[2:0]=111, rising edge	—	3.08	—	V		
LVDT[2:0]=111, falling edge	—	2.98	—	V		
$V_{LVDhyst}^{(1)}$	LVD hysteresis	—		100		mV
V_{POR}	Power on reset threshold	Rising edge	—	1.71	—	V
V_{PDR}	Power down reset threshold	Falling edge	—	1.67	—	V
$V_{PDRhyst}^{(1)}$	PDR hysteresis	—	—	40	—	mV
$t_{RSTTEMP}$	Reset temporization	—	—	2.5	—	ms

(1) Guaranteed by design, not tested in production.

4.6 Electrical sensitivity

The device is strained in order to determine its performance in terms of electrical sensitivity. Electrostatic discharges (ESD) are applied directly to the pins of the sample. Static latch-up

(LU) test is based on the two measurement methods.

Table 4-12. ESD characteristics

Symbol	Parameter	Conditions	Min	Typ	Max	Unit
$V_{ESD(HBM)}$	Electrostatic discharge voltage (human body model)	$T_A=25\text{ }^\circ\text{C}$; JESD22-A114	—	—	6000	V
$V_{ESD(CDM)}$	Electrostatic discharge voltage (charge device model)	$T_A=25\text{ }^\circ\text{C}$; JESD22-C101	—	—	2000	V

Table 4-13. Static latch-up characteristics

Symbol	Parameter	Conditions	Min	Typ	Max	Unit
LU	I-test	$T_A=25\text{ }^\circ\text{C}$; JESD78	—	—	± 200	mA
	V_{supply} over voltage		—	—	5.4	V

4.7 External clock characteristics

Table 4-14. High speed external clock (HXTAL) generated from a crystal/ceramic characteristics

Symbol	Parameter	Conditions	Min	Typ	Max	Unit
f_{HXTAL}	Crystal or ceramic frequency ⁽¹⁾	$V_{DD}=3.3\text{V}$	4	8	32	MHz
R_F	Feedback resistor	$V_{DD}=3.3\text{V}$	—	—	—	—
C_{HXTAL}	Recommended matching capacitance on OSCIN and OSCOUT	—	—	20	30	pF
$I_{DD(\text{HXTAL})}$	Crystal or ceramic operating current	$V_{DD}=3.3\text{V}$, $T_A=25\text{ }^\circ\text{C}$	—	1.0	—	mA
$g_{m(\text{HXTAL})}$	Crystal or ceramic transconductance	Startup	—	—	—	mA/V
t_s	Crystal or ceramic startup time	$V_{DD}=3.3\text{V}$, $T_A=25\text{ }^\circ\text{C}$	—	2	—	ms

(1) Guaranteed by design, not tested in production.

Note: $C_{\text{HXTAL1}} = C_{\text{HXTAL2}} = 2 \cdot (C_{\text{LOAD}} - C_s)$, For C_{HXTAL1} and C_{HXTAL2} , it is recommended matching capacitance on OSCIN and OSCOUT. For C_{LOAD} , it is crystal/ceramic load capacitance, provided by the crystal or ceramic manufacturer. For C_s , it is PCB and MCU pin stray capacitance (Typ. $C_s = 10\text{pf}$).

Table 4-15. High speed external user clock characteristics (HXTAL in bypass mode)

Symbol	Parameter	Conditions	Min	Typ	Max	Unit
$f_{\text{HXTAL_ext}}$	External clock source or oscillator frequency	$V_{DD}=3.3\text{V}$	1	8	50	MHz
V_{HXTALH}	OSCIN input pin high level voltage	$V_{DD}=3.3\text{V}$	$0.7V_D$	—	V_{DD}	V
V_{HXTALL}	OSCIN input pin low level voltage		V_{SS}	—	$0.3V_D$	

$t_{HL(HXTAL)}^{(1)}$	OSCIN high or low time	—	5	—	—	ns
$t_{R/F(HXTAL)}^{(1)}$	OSCIN rise or fall time	—	—	—	10	
$C_{IN}^{(1)}$	OSCIN input capacitance	—	—	5	—	pF
$DuCy_{(HXTAL)}$	Duty cycle	—	30	50	70	%

(1) Guaranteed by design, not tested in production.

Table 4-16. Low speed external clock (LXTAL) generated from a crystal/ceramic characteristics

Symbol	Parameter	Conditions	Min	Typ	Max	Unit
$f_{LXTAL}^{(1)}$	Crystal or ceramic frequency	$V_{DD}=3.3V$	—	32.768	—	KHz
R_F	Feedback resistor	$V_{DD}=3.3V$	—	—	—	MΩ
$C_{LXTAL}^{(1)}$	Recommended matching capacitance on OSC32IN and OSC32OUT	—	—	—	15	pF
$I_{DD(LXTAL)}$	Crystal or ceramic operating current	$V_{DD}=3.3V$, High Drive	—	1.2	—	μA
		$V_{DD}=3.3V$, Medium High Drive	—	1.0	—	
		$V_{DD}=3.3V$, Medium Low Drive	—	0.6	—	
		$V_{DD}=3.3V$, Low Drive	—	0.5	—	
$g_m(LXTAL)$	Crystal or ceramic transconductance	Startup	—	—	—	μA/V
$t_{SULXTAL}$	Crystal or ceramic startup time	$V_{DD}=3.3V$	—	2	—	s

(1) Guaranteed by design, not tested in production.

Note: $C_{LXTAL1} = C_{LXTAL2} = 2*(C_{LOAD} - C_S)$, For C_{LXTAL1} and C_{LXTAL2} , it is recommended matching capacitance on OSC32IN and OSC32OUT. For C_{LOAD} , it is crystal/ceramic load capacitance, provided by the crystal or ceramic manufacturer. For C_S , it is PCB and MCU pin stray capacitance (Typ. $C_S = 2pf \sim 7pf$).

Table 4-17. Low speed external clock (LXTAL) generated from an external clock source/oscillator characteristics

Symbol	Parameter	Conditions	Min	Typ	Max	Unit
$f_{LXTAL_ext}^{(1)}$	External clock source or oscillator frequency	$V_{DD}=3.3V$	—	32.768	1000	kHz
V_{LXTALH}	OSC32IN input pin high level voltage	$V_{DD}=3.3V$	$0.7V_{DD}$	—	V_{DD}	V
V_{LXTALL}	OSC32IN input pin low level voltage		V_{SS}	—	$0.3V_D$	
$t_{H/L(LXTAL)}^{(1)}$	OSC32IN high or low time	—	450	—	—	ns
$t_{R/F(LXTAL)}^{(1)}$	OSC32IN rise or fall time	—	—	—	50	
$C_{IN}^{(1)}$	OSC32IN input capacitance	—	—	5	—	pF
$DuCy_{(LXTAL)}$	Duty cycle	—	30	50	70	%

(1) Guaranteed by design, not tested in production.

4.8 Internal clock characteristics

Table 4-18. High speed internal clock (IRC8M) characteristics⁽¹⁾

Symbol	Parameter	Conditions	Min	Typ	Max	Unit
f_{IRC8M}	High Speed Internal Oscillator (IRC8M) frequency	$V_{DD}=3.3V$	—	8	—	MHz
ACC_{IRC8M}	IRC8M oscillator Frequency accuracy, Factory-trimmed	$V_{DD}=3.3V, T_A=-40^{\circ}C \sim +105^{\circ}C^{(2)}$	-4.0	—	+5.0	%
		$V_{DD}=3.3V, T_A=0^{\circ}C \sim +85^{\circ}C^{(2)}$	-2.0	—	+2.0	%
		$V_{DD}=3.3V, T_A=25^{\circ}C$	-1.0	—	+1.0	%
	IRC8M oscillator Frequency accuracy, User trimming step	—	—	0.5	—	%
D_{IRC8M}	IRC8M oscillator duty cycle	$V_{DD}=3.3V, f_{IRC8M}=8MHz$	45	50	55	%
$I_{DDIRC8M}$	IRC8M oscillator operating current	$V_{DD}=3.3V, f_{IRC8M}=8MHz$	—	55	80	μA
$t_{SUIRC8M}^{(3)}$	IRC8M oscillator startup time	$V_{DD}=3.3V, f_{IRC8M}=8MHz$	—	1.5	2	us

(1) $V_{DD} = 3.3V, T_A = -40$ to $105^{\circ}C$ unless otherwise specified.

(2) Based on characterization, not tested in production.

(3) Guaranteed by design, not tested in production.

Table 4-19. High speed internal clock (IRC28M) characteristics⁽¹⁾

Symbol	Parameter	Conditions	Min	Typ	Max	Unit
f_{IRC28M}	High Speed Internal Oscillator (IRC28M) frequency	$V_{DD}=3.3V$	—	28	—	MHz
ACC_{IRC28M}	IRC28M oscillator Frequency accuracy, Factory-trimmed	$V_{DD}=3.3V, T_A=-40^{\circ}C \sim +105^{\circ}C^{(2)}$	-4.0	—	+5.0	%
		$V_{DD}=3.3V, T_A=0^{\circ}C \sim +85^{\circ}C^{(2)}$	-3.0	—	+3.0	%
		$V_{DD}=3.3V, T_A=25^{\circ}C$	-2.0	—	+2.0	%
	IRC28M oscillator Frequency accuracy, User trimming step	—	—	0.5	—	%
D_{IRC28M}	IRC28M oscillator duty cycle	$V_{DD}=3.3V, f_{IRC28M}=16MHz$	45	50	55	%
$I_{DDIRC28M}$	IRC28M oscillator operating current	$V_{DD}=3.3V, f_{IRC28M}=16MHz$	—	140	200	μA
$t_{SUIRC28M}^{(3)}$	IRC28M oscillator startup time	$V_{DD}=3.3V, f_{IRC28M}=16MHz$	—	1.5	2	μs

(1) $V_{DD} = 3.3V, T_A = -40$ to $105^{\circ}C$ unless otherwise specified.

(2) Based on characterization, not tested in production.

(3) Guaranteed by design, not tested in production.

Table 4-20. Low speed internal clock (IRC40K) characteristics⁽¹⁾

Symbol	Parameter	Conditions	Min	Typ	Max	Unit
$f_{IRC40K}^{(2)}$	Low Speed Internal oscillator (IRC40K) frequency	$V_{DD}=V_{DDA}=3.3V, T_A=-40^{\circ}C \sim +85^{\circ}C$	30	38.5	60	KHz

Symbol	Parameter	Conditions	Min	Typ	Max	Unit
$I_{DDIRC40K}^{(3)}$	IRC40K oscillator operating current	$V_{DD}=V_{DDA}=3.3V, T_A=25^{\circ}C$	—	0.41	—	μA
$t_{SUIRC40K}^{(3)}$	IRC40K oscillator startup time	$V_{DD}=V_{DDA}=3.3V, T_A=25^{\circ}C$	—	33	—	μs

(1) $V_{DD} = 3.3 V, T_A = -40$ to $105^{\circ}C$ unless otherwise specified.

(2) Based on characterization, not tested in production.

(3) Guaranteed by design, not tested in production.

4.9 PLL characteristics

Table 4-21. PLL characteristics

Symbol	Parameter	Conditions	Min	Typ	Max	Unit
f_{PLLIN}	PLL input clock frequency	—	1 ⁽¹⁾	—	25	MHz
f_{PLLOUT}	PLL output clock frequency	—	16	—	72	MHz
t_{LOCK}	PLL lock time	—	—	—	300	μs
$I_{DD}^{(2)}$	Current consumption on V_{DD}	VCO freq=72MHz	—	130	—	μA
Jitter _{PLL} ⁽³⁾	Cycle to cycle Jitter	System clock	—	300	—	ps

(1) Guaranteed by design, not tested in production.

(2) Based on characterization, not tested in production.

(3) Value given with main PLL running.

4.10 Memory characteristics

Table 4-22. Flash memory characteristics

Symbol	Parameter	Conditions	Min ⁽¹⁾	Typ	Max ⁽¹⁾	Unit
PE _{CYC}	Number of guaranteed program /erase cycles before failure (Endurance)	$T_A=-40^{\circ}C \sim +85^{\circ}C$	100	—	—	kcycle
t_{RET}	Data retention time	10k cycles at $T_A=85^{\circ}C$	10	—	—	year
t_{PROG}	Word programming time	$T_A=-40^{\circ}C \sim +85^{\circ}C$	37	—	42	μs
t_{ERASE}	Page erase time	$T_A=-40^{\circ}C \sim +85^{\circ}C$	0.8	—	1.1	ms
t_{MERASE}	Mass erase time	$T_A=-40^{\circ}C \sim +85^{\circ}C$	3.2	—	4	ms

(1) Based on characterization, not tested in production.

4.11 NRST pin characteristics

Table 4-23. NRST pin characteristics

Symbol	Parameter	Conditions	Min	Typ	Max	Unit
$V_{IL(NRST)}$	NRST Input low level voltage	$V_{DD}=V_{DDA}=1.8V$	-0.5	—	0.71	V

$V_{IH(NRST)}^{(1)}$	NRST Input high level voltage		1.08	—	$V_{DD}+0.5$	
V_{hyst}	Schmidt trigger Voltage hysteresis		—	370	—	mV
$V_{IL(NRST)}^{(1)}$	NRST Input low level voltage	$V_{DD}=V_{DDA}=2.5V$	-0.5	—	1.05	V
$V_{IH(NRST)}^{(1)}$	NRST Input high level voltage		1.42	—	$V_{DD}+0.5$	
V_{hyst}	Schmidt trigger Voltage hysteresis		—	370	—	mV
$V_{IL(NRST)}^{(1)}$	NRST Input low level voltage	$V_{DD}=V_{DDA}=3.3V$	-0.5	—	1.4	V
$V_{IH(NRST)}^{(1)}$	NRST Input high level voltage		1.8	—	$V_{DD}+0.5$	
V_{hyst}	Schmidt trigger Voltage hysteresis		—	400	—	mV
$V_{IL(NRST)}^{(1)}$	NRST Input low level voltage	$V_{DD}=V_{DDA}=3.6V$	-0.5	—	1.53	V
$V_{IH(NRST)}^{(1)}$	NRST Input high level voltage		1.95	—	$V_{DD}+0.5$	
V_{hyst}	Schmidt trigger Voltage hysteresis		—	420	—	mV
$R_{pu}^{(2)}$	Pull-up equivalent resistor	—	—	40.3	—	K Ω

(1) Guaranteed by design, not tested in production.

(2) Based on characterization, not tested in production.

4.12 GPIO characteristics

Table 4-24. I/O port DC characteristics

Symbol	Parameter	Conditions	Min	Typ	Max	Unit	
V_{IL}	Standard IO Low level input voltage	$V_{DD}=1.8V$	V_{SS}	—	0.80	V	
		$V_{DD}=2.5V$		—	1.10		
		$V_{DD}=3.3V$		—	1.40		
		$V_{DD}=3.6V$		—	1.60		
	5V-tolerant IO Low level input voltage	$V_{DD}=1.8V$	V_{SS}	—	0.80	V	
		$V_{DD}=2.5V$		—	1.10		
		$V_{DD}=3.3V$		—	1.40		
		$V_{DD}=3.6V$		—	1.60		
V_{IH}	Standard IO High level input voltage	$V_{DD}=1.8V$	1.10	—	V_{DD}	V	
		$V_{DD}=2.5V$	1.50	—			
		$V_{DD}=3.3V$	1.90	—			
		$V_{DD}=3.6V$	2.00	—			
	5V-tolerant IO High level input voltage	$V_{DD}=1.8V$	V_{DD}	1.10	—	V_{DD}	V
		$V_{DD}=2.5V$		1.50	—		
		$V_{DD}=3.3V$		1.90	—		
		$V_{DD}=3.6V$		2.00	—		
V_{OL}	Low level output voltage for an IO Pin ($I_{IO} = +8mA$)	$V_{DD}=1.8V$	—	—	0.20	V	
		$V_{DD}=2.5V$	—	—	0.20		
		$V_{DD}=3.3V$	—	—	0.10		
		$V_{DD}=3.6V$	—	—	0.10		
V_{OL}	Low level output voltage for an IO Pin ($I_{IO} = +20mA$)	$V_{DD}=1.8V$	—	—	—	V	
		$V_{DD}=2.5V$	—	—	0.50		
		$V_{DD}=3.3V$	—	—	0.40		

Symbol	Parameter	Conditions	Min	Typ	Max	Unit
		$V_{DD}=3.6V$	—	—	0.40	
V_{OH}	High level output voltage for an IO Pin ($I_{IO} = +8mA$)	$V_{DD}=1.8V$	1.50	—	—	V
		$V_{DD}=2.5V$	2.30	—	—	
		$V_{DD}=3.3V$	3.10	—	—	
		$V_{DD}=3.6V$	3.40	—	—	
V_{OH}	High level output voltage for an IO Pin ($I_{IO} = +20mA$)	$V_{DD}=1.8V$	—	—	—	V
		$V_{DD}=2.5V$	1.90	—	—	
		$V_{DD}=3.3V$	2.80	—	—	
		$V_{DD}=3.6V$	3.10	—	—	
R_{PU}	Internal pull-up resistor	—	—	40	—	k Ω
R_{PD}	Internal pull-down resistor	—	—	40	—	k Ω

 Table 4-25. I/O port AC characteristics^{(1) (2)}

GPIOx_OSPD[1:0] bit value	Parameter	Conditions	Typ	Max	Unit
GPIOx_OSPD0->OSPDy[1:0] =X0 (IO_Speed = 2MHz)	Maximum frequency ⁽³⁾	$V_{DD}=1.8V, C_L=10pF$	2	10	MHz
		$V_{DD}=1.8V, C_L=30pF$	2	8	
		$V_{DD}=1.8V, C_L=50pF$	2	6	
	Output high/ low to low/ high level fall/ rise time	$V_{DD}=1.8V, C_L=10pF$	24.4/23.4	29.4/33.4	ns
		$V_{DD}=1.8V, C_L=30pF$	31.6/29.8	37.6/36.8	
		$V_{DD}=1.8V, C_L=50pF$	49/43.2	51/42.2	
GPIOx_OSPD0->OSPDy[1:0] =01 (IO_Speed = 10MHz)	Maximum frequency ⁽³⁾	$V_{DD}=1.8V, C_L=10pF$	10	32	MHz
		$V_{DD}=1.8V, C_L=30pF$	10	26	
		$V_{DD}=1.8V, C_L=50pF$	10	18	
	Output high/ low to low/ high level fall/ rise time	$V_{DD}=1.8V, C_L=10pF$	8.8/9.2	10.0/10.2	ns
		$V_{DD}=1.8V, C_L=30pF$	12.0/12.8	12.0/11.0	
		$V_{DD}=1.8V, C_L=50pF$	15/13.6	17.2/15.8	
GPIOx_OSPD0->OSPDy[1:0] =11 (IO_Speed = 50MHz)	Maximum frequency ⁽³⁾	$V_{DD}=1.8V, C_L=10pF$	—	20	MHz
		$V_{DD}=1.8V, C_L=30pF$	50	54	
		$V_{DD}=1.8V, C_L=50pF$	—	40	
	Output high/ low to low/ high level fall/ rise time	$V_{DD}=1.8V, C_L=10pF$	—	3.6/3.2	ns
		$V_{DD}=1.8V, C_L=30pF$	8.0/5.0	7.4/4.0	
		$V_{DD}=1.8V, C_L=50pF$	—	7.8/6.2	
GPIOx_OSPD0->OSPDy[1:0] =X0 (IO_Speed = 2MHz)	Maximum frequency ⁽³⁾	$V_{DD}=3.3V, C_L=10pF$	2	16	MHz
		$V_{DD}=3.3V, C_L=30pF$	2	16	
		$V_{DD}=3.3V, C_L=50pF$	2	12	
	Output high/ low to low/ high level fall/ rise time	$V_{DD}=3.3V, C_L=10pF$	13.8/11.4	16.4/11.8	ns
		$V_{DD}=3.3V, C_L=30pF$	19.0/14.8	19.2/17.8	
		$V_{DD}=3.3V, C_L=50pF$	28.2/22.8	27.2/24.4	
GPIOx_OSPD0->OSPDy[1:0] =01 (IO_Speed = 10MHz)	Maximum frequency ⁽³⁾	$V_{DD}=3.3V, C_L=10pF$	10	72	MHz
		$V_{DD}=3.3V, C_L=30pF$	10	72	
		$V_{DD}=3.3V, C_L=50pF$	10	40	

GPIOx_OSPD[1:0] bit value	Parameter	Conditions	Typ	Max	Unit
	Output high/ low to low/ high level fall/ rise time	V _{DD} =3.3V, C _L =10pF	3.4/2.8	4.0/3.4	ns
		V _{DD} =3.3V, C _L =30pF	4.6/3.4	5.2/4.0	
		V _{DD} =3.3V, C _L =50pF	8.0/6.4	8.2/6.2	
GPIOx_OSPD0->OSPDy[1:0] =11 (IO_Speed = 50MHz)	Maximum frequency ⁽³⁾	V _{DD} =3.3V, C _L =10pF	—	32	MHz
		V _{DD} =3.3V, C _L =30pF	—	46	
		V _{DD} =3.3V, C _L =50pF	—	40	
	Output high/ low to low/ high level fall/ rise time	V _{DD} =3.3V, C _L =10pF	—	2.4/2.6	ns
		V _{DD} =3.3V, C _L =30pF	—	2.6/2.4	
		V _{DD} =3.3V, C _L =50pF	—	8.4/3.2	
GPIOx_OSPD0->OSPDy[1:0] =X0 (IO_Speed = 2MHz)	Maximum frequency ⁽³⁾	V _{DD} =3.6V, C _L =10pF	2	16	MHz
		V _{DD} =3.6V, C _L =30pF	2	16	
		V _{DD} =3.6V, C _L =50pF	2	12	
	Output high/ low to low/ high level fall/ rise time	V _{DD} =3.6V, C _L =10pF	13.2/10.6	12.0/10.4	ns
		V _{DD} =3.6V, C _L =30pF	17.2/14.4	18.8/15.4	
		V _{DD} =3.6V, C _L =50pF	26.8/22.2	26.4/21.8	
GPIOx_OSPD0->OSPDy[1:0] =01 (IO_Speed = 10MHz)	Maximum frequency ⁽³⁾	V _{DD} =3.6V, C _L =10pF	10	72	MHz
		V _{DD} =3.6V, C _L =30pF	10	72	
		V _{DD} =3.6V, C _L =50pF	10	40	
	Output high/ low to low/ high level fall/ rise time	V _{DD} =3.6V, C _L =10pF	3.2/2.8	3.6/3.2	ns
		V _{DD} =3.6V, C _L =30pF	3.8/3.2	4.4/3.4	
		V _{DD} =3.6V, C _L =50pF	7.6/6.0	8.0/6.0	
GPIOx_OSPD0->OSPDy[1:0] =11 (IO_Speed = 50MHz)	Maximum frequency ⁽³⁾	V _{DD} =3.6V, C _L =10pF	—	42	MHz
		V _{DD} =3.6V, C _L =30pF	—	46	
		V _{DD} =3.6V, C _L =50pF	—	36	
	Output high/ low to low/ high level fall/ rise time	V _{DD} =3.6V, C _L =10pF	—	3.0/9.6	ns
		V _{DD} =3.6V, C _L =30pF	—	2.4/2.4	
		V _{DD} =3.6V, C _L =50pF	—	3.2/3.2	

(1) Based on characterization, not tested in production.

(2) The I/O speed is configured using the GPIOx_OSPD0->OSPDy [1:0] bits. Refer to the GD32E230xx user manual which is selected to set the GPIO port output speed.

(3) The maximum frequency is defined in [Figure 4-1. I/O port AC characteristics definition](#).

Figure 4-1. I/O port AC characteristics definition

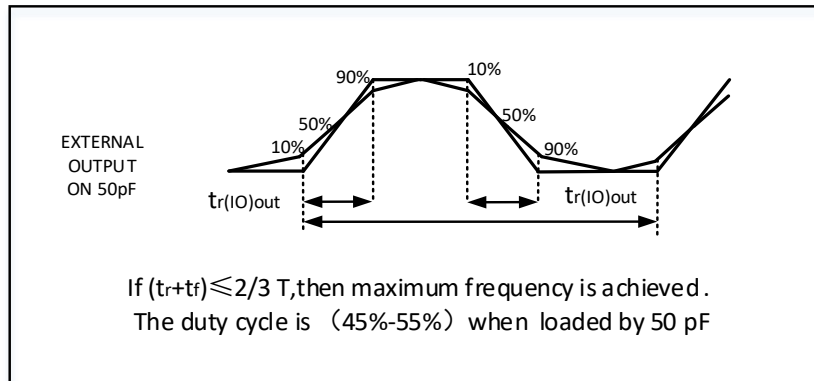

4.13 ADC characteristics

Table 4-19. ADC characteristics

Symbol	Parameter	Conditions	Min	Typ	Max	Unit
V _{DDA}	Operating voltage	—	2.4	3.3	3.6	V
V _{IN}	ADC input voltage range	—	0	—	V _{REF+}	V
f _{ADC}	ADC clock	—	0.1	—	28	MHZ
f _S ⁽¹⁾	Sampling rate	12-bit	0.007	—	2	MSP S
		10-bit	0.008	—	2.3	
		8-bit	0.01	—	2.8	
		6-bit	0.011	—	3.5	
V _{IN}	Analog input voltage	10 external;2 internal	0	—	V _{DDA}	V
V _{REF+}	Positive Reference Voltage	—	—	V _{DDA}	—	V
V _{REF-}	Negative Reference Voltage	—	—	0	—	V
R _{AIN} ⁽¹⁾	External input impedance	See Equation 2	—	—	50.6	kΩ
R _{ADC} ⁽¹⁾	Input sampling switch resistance	—	—	—	0.5	kΩ
C _{ADC} ⁽¹⁾	Input sampling capacitance	No pin/pad capacitance included	—	—	4	pF
t _{CAL}	Calibration time	f _{ADC} =28MHz	—	3.12	—	μs
t _S	Sampling time	f _{ADC} =28MHz	0.05	—	8.55	μs
t _{CONV} ⁽¹⁾	Total conversion time(including sampling time)	12-bit	—	14	—	1/ f _{ADC}
		10-bit	—	12	—	
		8-bit	—	10	—	
		6-bit	—	8	—	
t _{SU} ⁽¹⁾	Startup time	—	—	—	1	μs

(1) Based on characterization, not tested in production.

Equation 2: $R_{AIN} \text{ max formula } R_{AIN} < \frac{T_s}{f_{ADC} * C_{ADC} * \ln(2^{N+2})} - R_{ADC}$

The formula above (Equation 2) is used to determine the maximum external impedance allowed for an error below 1/4 of LSB. Here N=12 (from 12-bit resolution).

Table 4-20. ADC R_{AIN} max for $f_{ADC} = 28MHz^{(1)}$

T_s (cycles)	t_s (μs)	R_{AINmax} (K Ω)
1.5	0.05	0.88
7.5	0.27	6.4
13.5	0.48	11.9
28.5	1.02	25.7
41.5	1.48	37.7
55.5	1.98	50.6
71.5	2.55	NA
239.5	8.55	NA

(1) Based on characterization, not tested in production.

4.14 Temperature sensor characteristics

Table 4-26. Temperature sensor characteristics

Symbol	Parameter	Min	Typ	Max	Unit
$T_L^{(1)}$	VSENSE linearity with temperature	—	± 1.5	—	$^{\circ}C$
Avg_Slope ⁽¹⁾	Average slope	—	4.3	—	mV/ $^{\circ}C$
$V_{25}^{(1)}$	Voltage at 25 $^{\circ}C$	—	1.45	—	V
t_{START}	Startup time	—	—	—	μs
$t_{s_temp}^{(2)(3)}$	ADC sampling time when reading the temperature	—	17.1	—	μs

(1) Based on characterization, not tested in production.

(2) Guaranteed by design, not tested in production.

(3). Shortest sampling time can be determined in the application by multiple iterations.

4.15 Comparators characteristics

Table 4-27. CMP characteristics

Symbol	Parameter	Conditions	Min	Typ	Max ⁽¹⁾	Unit
V_{DDA}	Operating voltage	—	1.8	3.3	3.6	V
V_{IN}	Input voltage range	—	0	—	V_{DDA}	V
V_{BG}	Scaler input voltage	—	—	1.2	—	V
V_{SC}	Scaler offset voltage	—	—	—	—	mV
t_D	Propagation delay for 200mV step with 100mV overdrive	Ultra-low power mode	—	0.98	—	μs
		Low power mode	—	0.25	—	μs
		Medium power mode	—	0.12	—	μs
		High speed power mode	—	33	—	ns
	Propagation delay for full range step with 100mV	Ultra-low power mode	—	—	—	μs
		Low power mode	—	—	—	μs

	overdrive	Medium power mode	—	—	—	μs
		High speed power mode	—	—	—	ns
I _{DD}	Current consumption	Ultra-low power mode	—	2.2	—	μA
		Low power mode	—	3.2	—	
		Medium power mode	—	8.1	—	
		High speed power mode	—	46.9	—	
V _{offset}	Offset error	—	—	±4	—	mV
V _{hyst}	Hysteresis Voltage	No Hysteresis	—	0	—	mV
		Low Hysteresis	—	11	—	
		Medium Hysteresis	—	22	—	
		High Hysteresis	—	43	—	

(1) Based on characterization, not tested in production.

4.16 TIMER characteristics

Table 4-28. TIMER characteristics

Symbol	Parameter	Conditions	Min	Max	Unit
t _{res}	Timer resolution time	—	1	—	t _{TIMERxCLK}
		f _{TIMERxCLK} = 72 MHz	13.9	—	ns
f _{EXT}	Timer external clock frequency	—	0	f _{TIMERxCLK} /2	MHz
		f _{TIMERxCLK} = 72 MHz	0	36	MHz
RES	Timer resolution	—	—	16	bit
t _{COUNTER}	16-bit counter clock period when internal clock is selected	—	1	65536	t _{TIMERxCLK}
		f _{TIMERxCLK} = 72 MHz	0.0139	910	μs
t _{MAX_COUNT}	Maximum possible count	—	—	65536 × 65536	t _{TIMERxCLK}
		f _{TIMERxCLK} = 72 MHz	—	59.6	s

4.17 WDGT characteristics

Table 4-29. FWDGT min/max timeout period at 40 kHz (IRC40K)

Prescaler divider	PR[2:0] bits	Min timeout RLD[11:0]= 0x000	Max timeout RLD[11:0]= 0xFFFF	Unit
1/4	000	0.1	409.6	ms
1/8	001	0.2	819.2	
1/16	010	0.4	1638.4	
1/32	011	0.8	3276.8	
1/64	100	1.6	6553.6	
1/128	101	3.2	13107.2	
1/256	110 or 111	6.4	26214.4	

Table 4-30. WWDGT min-max timeout value @72 MHz (f_{PCLK1})

Prescaler divider	PSC[2:0]	Min timeout value CNT[6:0] = 0x40	Unit	Max timeout value CNT[6:0] = 0x7F	Unit
1/1	00	56.9	μs	3.64	ms
1/2	01	113.8		7.28	
1/4	10	227.6		14.56	
1/8	11	455.1		29.13	

4.18 I2C characteristics

Table 4-31. I2C characteristics

Symbol	Parameter	Conditions	Standard mode ⁽¹⁾		Fast mode ^{(1) (2)}		Unit
			Min	Max	Min	Max	
f_{SCL}	SCL clock frequency	—	0	100	0	1000	KHz
$t_{SCL(H)}$	SCL clock high time	—	4.0	—	0.6	—	μs
$t_{SCL(L)}$	SCL clock low time	—	4.7	—	1.3	—	μs
$t_{su(SDA)}$	SDA setup time	—	250	—	100	—	ns
$t_h(SDA)$	SDA data hold time	—	0 ⁽³⁾	3450	0	900	ns
$t_r(SDA/SCL)$	SDA and SCL rise time	—	—	1000	—	300	ns
$t_f(SDA/SCL)$	SDA and SCL fall time	—	—	300	—	300	ns
$t_h(STA)$	Start condition hold time	—	4.0	—	0.6	—	us

(1) Guaranteed by design, not tested in production.

(2) f_{PCLK1} must be at least 2 MHz to achieve standard mode I2C frequencies. It must be at least 4 MHz to achieve fast mode I2C frequencies, and a multiple of 10 MHz to reach the 400 kHz maximum I2C fast mode clock.

(3) The device must internally provide a hold time of at least 300 ns for the SDA signal in order to bridge the undefined region of the falling edge of SCL.

4.19 SPI characteristics

Table 4-32. Standard SPI characteristics⁽¹⁾

Symbol	Parameter	Conditions	Min	Typ	Max	Unit
f_{SCK}	SCK clock frequency	—	—	—	18	MHz
$t_{SCK(H)}$	SCK clock high time	—	25	27	29	ns
$t_{SCK(L)}$	SCK clock low time	—	25	27	29	ns
SPI master mode						
$t_{V(MO)}$	Data output valid time	—	—	—	2	ns
$t_{SU(MI)}$	Data input setup time	—	5	—	—	ns
$t_{H(MI)}$	Data input hold time	—	5	—	—	ns
SPI slave mode						
$t_{SU(NSS)}$	NSS enable setup time	$f_{PCLK}=72\text{MHz}$	$4T_{PCLK}$	—	—	ns

$t_{H(NSS)}$	NSS enable hold time	$f_{PCLK}=72MHz$	$2T_{PCLK}$	—	—	ns
$t_{A(SO)}$	Data output access time	$f_{PCLK}=72MHz$	2	—	55	ns
$t_{DIS(SO)}$	Data output disable time	—	3	—	10	ns
$t_{V(SO)}$	Data output valid time	—	—	—	29	ns
$t_{SU(SI)}$	Data input setup time	—	2	—	—	ns
$t_{H(SI)}$	Data input hold time	—	0	—	—	ns

(1).Data based on characterization results, not tested in production.

4.20 I2S characteristics

Table 4-33. I2S characteristics⁽¹⁾

Symbol	Parameter	Conditions	Min	Typ	Max	Unit
f_{CK}	Clock frequency	Master mode (data: 16 bits, Audio frequency = 48 kHz)	—	—	6	MHz
		Slave mode	—	—	6	
t_H	Clock high time	$f_{CK}=6MHz$	—	—	83.33	ns
t_L	Clock low time		—	—	83.33	ns
$t_{V(WS)}$	WS valid time	Master mode	0	—	2	ns
$t_{H(WS)}$	WS hold time	Master mode	0	—	—	ns
$t_{SU(WS)}$	WS setup time	Slave mode	0	—	—	ns
$t_{H(WS)}$	WS hold time	Slave mode	0.5	—	—	ns
$DuCy_{(SCK)}$	I2S slave input clock duty cycle	Slave mode	30	—	70	%
$t_{SU(SD_MR)}$	Data input setup time	Master mode	2	—	—	ns
$t_{SU(SD_SR)}$	Data input setup time	Slave mode	0	—	—	ns
$t_{H(SD_MR)}$	Data input hold time	Master receiver	1.5	—	—	ns
$t_{H(SD_SR)}$		Slave receiver	1.5	—	—	ns
$t_{V(SD_ST)}$	Data output valid time	Slave transmitter (after enable edge)	—	—	11	ns
$t_{H(SD_ST)}$	Data output hold time	Slave transmitter (after enable edge)	3	—	—	ns
$t_{V(SD_MT)}$	Data output valid time	Master transmitter (after enable edge)	—	—	11	ns
$t_{H(SD_MT)}$	Data output hold time	Master transmitter (after enable edge)	0	—	—	ns

(1) Data based on characterization results, not tested in production.

4.21 USART characteristics

Table 4-34. USART characteristics⁽¹⁾

Symbol	Parameter	Conditions	Min	Typ	Max	Unit
f _{SCK}	SCK clock frequency	—	—	—	36	MHz
t _{SCK(H)}	SCK clock high time	—	13.5	—	—	ns
t _{SCK(L)}	SCK clock low time	—	13.5	—	—	ns

(1) Data based on characterization results, not tested in production.

5 Package information

5.1 TSSOP package outline dimensions

Figure 5-1. TSSOP package outline

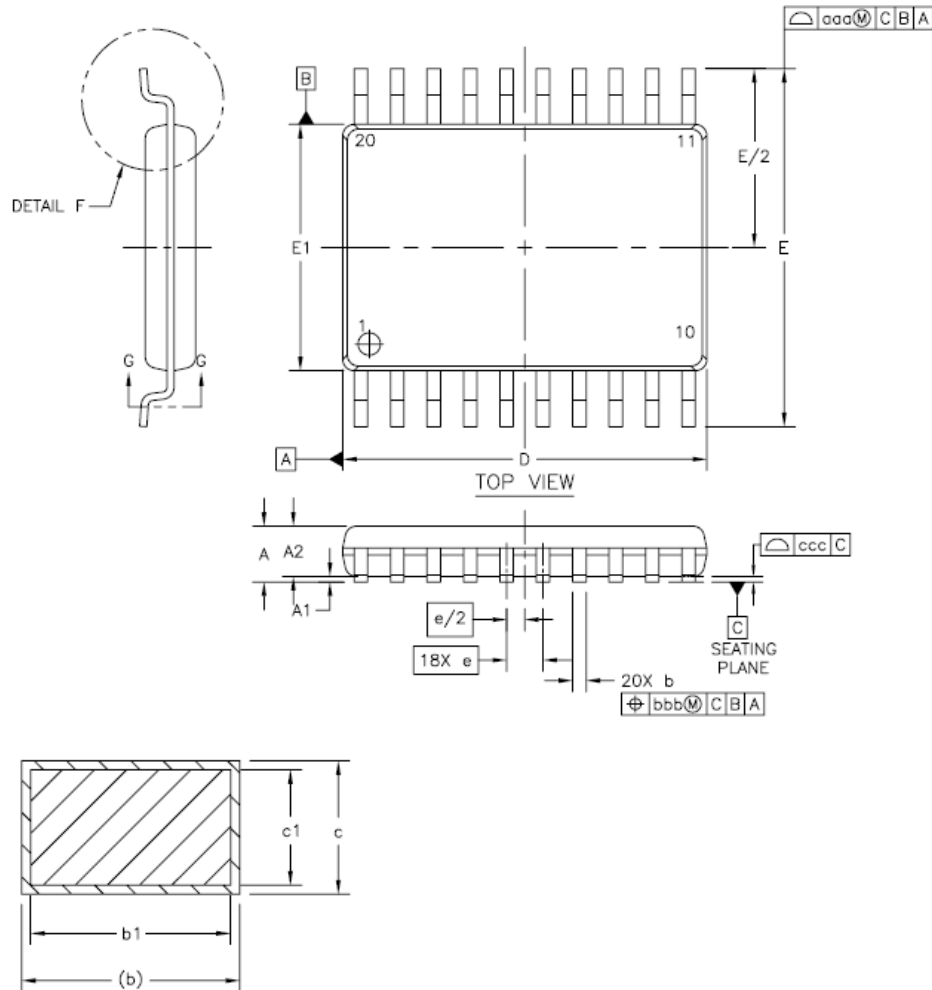

Table 5-1. TSSOP20 package dimensions

Symbol	Dimensions (mm)			Symbol	Dimensions (mm)		
	Min	Typ	Max		Min	Typ	Max
A	-	-	1.2	c1	0.09	-	0.16
A1	0.05	-	1.15	D	6.4	6.5	6.6
A2	0.80	1.00	1.05	E1	4.3	4.4	4.5
b	0.19	-	0.30	E	6.40		
B1	0.19	0.22	0.25	e	0.65		
c	0.09	-	0.20	L	0.45	0.6	0.75

5.2 QFN package outline dimensions

Figure 5-2. QFN package outline

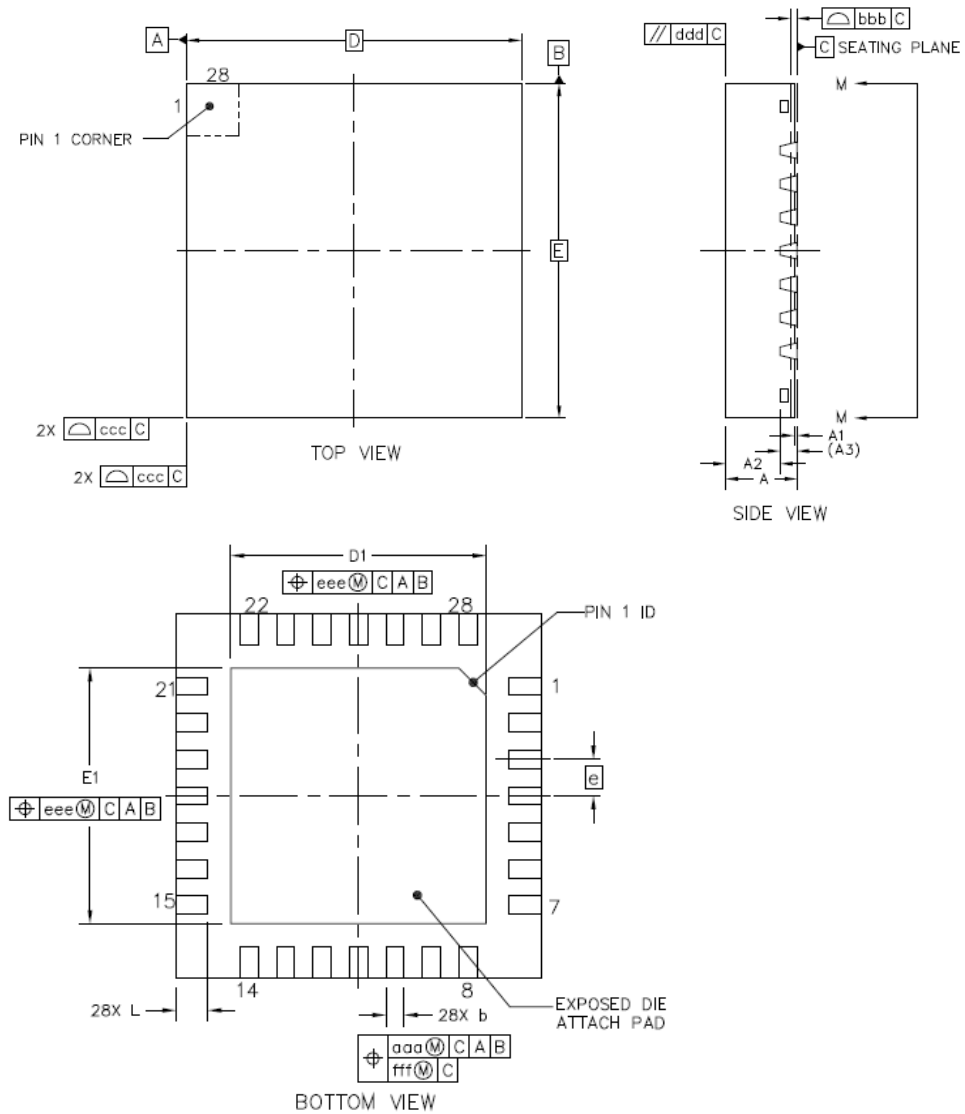

Table 5-2. QFN package dimensions

Symbol	QFN28			QFN32		
	Min	Typ	Max	Min	Typ	Max
A	0.8	0.85	0.9	0.8	0.85	0.9
A1	0	0.035	0.05	0	0.035	0.05
A2	-	0.65	0.67	-	0.65	0.67
A3	-	0.203	-	-	0.203	-
D	-	4.0	-	-	5.0	-
E	-	4.0	-	-	5.0	-
D1	2.7	2.8	2.9	3.4	3.5	3.6
E1	2.7	2.8	2.9	3.4	3.5	3.6
L	0.25	0.35	0.45	0.3	0.4	0.5
e	0.4			0.5		
b	0.15	0.2	0.25	0.2	0.25	0.3

(Original dimensions are in millimeters)

5.3 LQFP package outline dimensions

Figure 5-3. LQFP package outline

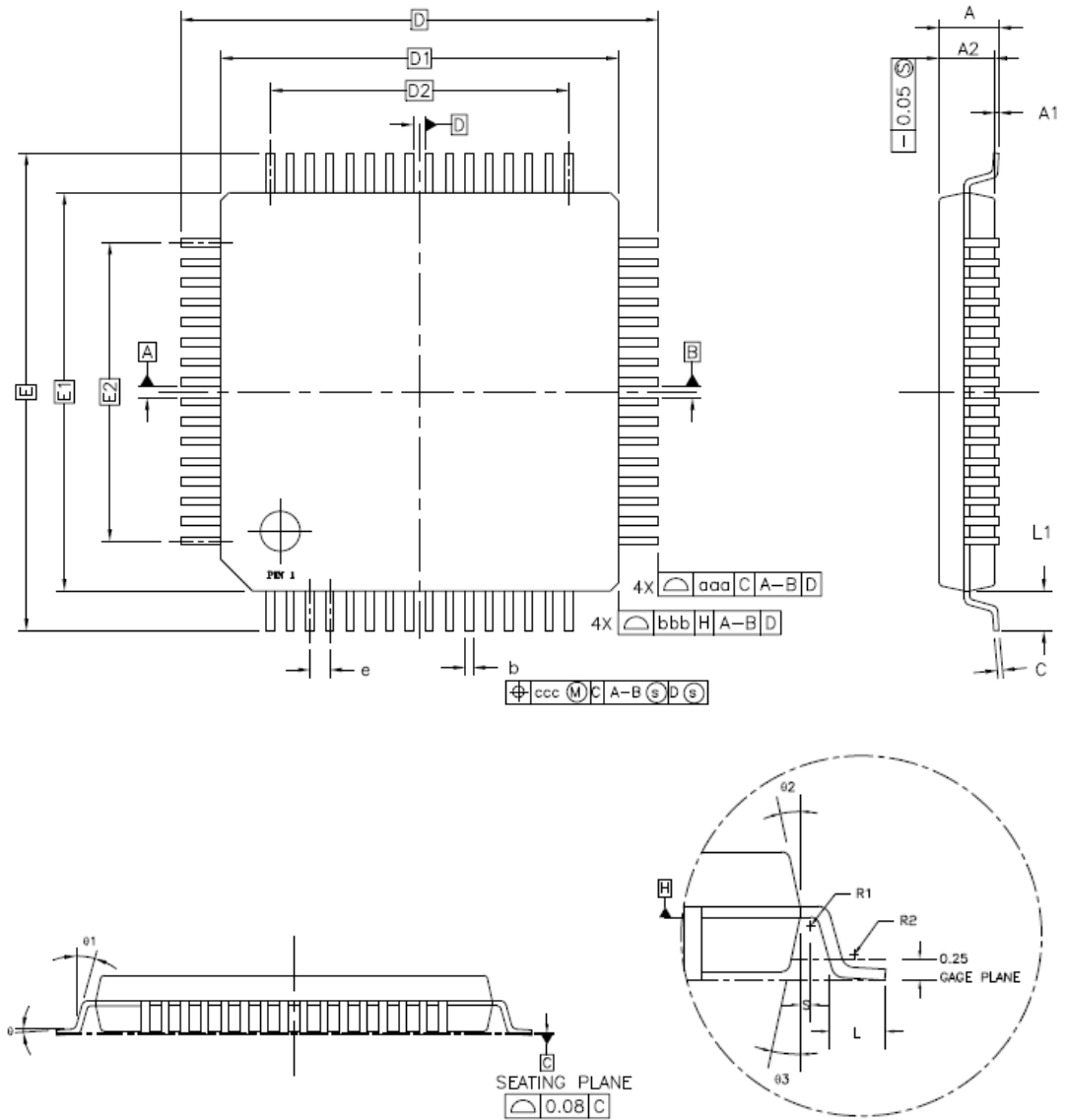

Table 5-3. LQFP package dimensions

Symbol	LQFP32			LQFP48		
	Min	Typ	Max	Min	Typ	Max
A	-	-	1.60	-	-	1.50
A1	0.05	-	0.25	0.05	-	0.15
A2	1.35	1.40	1.45	0.95	1.00	1.35
D	-	9.00	-	-	9.00	-
D1	-	7.00	-	-	7.00	-
E	-	9.00	-	-	9.00	-
E1	-	7.00	-	-	7.00	-
R1	0.08	-	-	0.08	-	-
R2	0.08	-	0.20	0.08	-	0.20
θ	0°	3.5°	7°	0°	3.5°	7°
θ_1	0°	-	-	0°	-	-
θ_2	11°	12°	13°	11°	12°	13°
θ_3	11°	12°	13°	11°	12°	13°
c	0.09	-	0.20	0.09	-	0.20
L	0.45	0.60	0.75	0.45	0.60	0.75
L1	-	1.00	-	-	1.00	-
S	0.20	-	-	0.20	-	-
b	0.17	0.22	0.27	0.17	0.22	0.27
e	-	0.50	-	-	0.50	-
D2	-	5.50	-	-	5.50	-
E2	-	5.50	-	-	5.50	-
aaa	0.20			0.20		
bbb	0.20			0.20		
ccc	0.08			0.08		

(Original dimensions are in millimeters)

6 Ordering information

Table 6-1. Part ordering code for GD32E230xx devices

Ordering code	Flash (KB)	Package	Package type	Temperature operating range
GD32E230F4P6	16	TSSOP20	Green	Industrial -40°C to +85°C
GD32E230F6P6	32	TSSOP20	Green	Industrial -40°C to +85°C
GD32E230F8P6	64	TSSOP20	Green	Industrial -40°C to +85°C
GD32E230G4U6	16	QFN28	Green	Industrial -40°C to +85°C
GD32E230G6U6	32	QFN28	Green	Industrial -40°C to +85°C
GD32E230G8U6	64	QFN28	Green	Industrial -40°C to +85°C
GD32E230K4U6	16	QFN32	Green	Industrial -40°C to +85°C
GD32E230K6U6	32	QFN32	Green	Industrial -40°C to +85°C
GD32E230K8U6	64	QFN32	Green	Industrial -40°C to +85°C
GD32E230K4T6	16	LQFP32	Green	Industrial -40°C to +85°C
GD32E230K6T6	32	LQFP32	Green	Industrial -40°C to +85°C
GD32E230K8T6	64	LQFP32	Green	Industrial -40°C to +85°C
GD32E230C4T6	16	LQFP48	Green	Industrial -40°C to +85°C
GD32E230C6T6	32	LQFP48	Green	Industrial -40°C to +85°C
GD32E230C8T6	64	LQFP48	Green	Industrial -40°C to +85°C

7 Revision history

Table 7-1. Revision history

Revision No.	Description	Date
1.0	Initial Release	Oct10, 2018

Important Notice

This document is the property of GigaDevice Semiconductor Inc. and its subsidiaries (the "Company"). This document, including any product of the Company described in this document (the "Product"), is owned by the Company under the intellectual property laws and treaties of the People's Republic of China and other jurisdictions worldwide. The Company reserves all rights under such laws and treaties and does not grant any license under its patents, copyrights, trademarks, or other intellectual property rights. The names and brands of third party referred thereto (if any) are the property of their respective owner and referred to for identification purposes only.

The Company makes no warranty of any kind, express or implied, with regard to this document or any Product, including, but not limited to, the implied warranties of merchantability and fitness for a particular purpose. The Company does not assume any liability arising out of the application or use of any Product described in this document. Any information provided in this document is provided only for reference purposes. It is the responsibility of the user of this document to properly design, program, and test the functionality and safety of any application made of this information and any resulting product. Except for customized products which has been expressly identified in the applicable agreement, the Products are designed, developed, and/or manufactured for ordinary business, industrial, personal, and/or household applications only. The Products are not designed, intended, or authorized for use as components in systems designed or intended for the operation of weapons, weapons systems, nuclear installations, atomic energy control instruments, combustion control instruments, airplane or spaceship instruments, transportation instruments, traffic signal instruments, life-support devices or systems, other medical devices or systems (including resuscitation equipment and surgical implants), pollution control or hazardous substances management, or other uses where the failure of the device or Product could cause personal injury, death, property or environmental damage ("Unintended Uses"). Customers shall take any and all actions to ensure using and selling the Products in accordance with the applicable laws and regulations. The Company is not liable, in whole or in part, and customers shall and hereby do release the Company as well as its suppliers and/or distributors from any claim, damage, or other liability arising from or related to all Unintended Uses of the Products. Customers shall indemnify and hold the Company as well as its suppliers and/or distributors harmless from and against all claims, costs, damages, and other liabilities, including claims for personal injury or death, arising from or related to any Unintended Uses of the Products.

Information in this document is provided solely in connection with the Products. The Company reserves the right to make changes, corrections, modifications or improvements to this document and Products and services described herein at any time, without notice.

单击下面可查看定价，库存，交付和生命周期等信息

[>>GigaDevice\(兆易创新\)](#)