

DESCRIPTION

The GLF74520 is an integrated power multiplexer switch with dual independent power switches connected to a single output pin to enable seamless transition between two input sources.

The GLF74520 provides an automatic selection mode as well as a manual selection mode by the combination of the logic input pins of EN and SEL. The EN input pin is used along with the select (SEL) input pin to select the automatic switching function, select VIN1 only, select VIN2 only, or turn both switches off. In the automatic selection mode, the GLF74520 automatically selects the higher input voltage source out of two input DC power supplies.

The GLF74520 features an ultra-efficient I_QSmart™ technology that supports the lowest R_{ON}, quiescent current (I_Q) and shutdown current (I_{SD}) in the industry. Low R_{ON} reduces conduction losses, while low I_Q and I_{SD} solutions help designers to reduce parasitic leakage current, improve system efficiency, and increase battery lifetime.

The GLF74520 blocks any cross conduction current between two input sources. When the switch is disabled, the GLF74520 prevents the reverse current to the input source from the output at any higher V_{out} than V_{in} condition.

The GLF74520 utilizes chip scale package technology with 6 bumps in a 0.97 mm x 1.47 mm x 0.55 mm package size with a 0.5 mm bump pitch.

FEATURES

- Two-Input and Single-Output Power Multiplexer Switch
- Automatic and Manual Input Selection Mode
- Supply Voltage Range: 1.5 V to 5.5 V
6 Vabs Max
- R_{ON} : 35 mΩ Typ. at 5.5 V_{IN1} or V_{IN2}
43 mΩ Typ. at 3.3 V_{IN1} or V_{IN2}
- 2 A Continuous Output Current Capability Per Channel
- Ultra-Low Supply Current at Operation
I_Q : 4 uA Typ at 5.5 V_{IN}
- Ultra-Low Stand-by Current
I_{SD} : 20 nA Typ at 5.5 V_{IN}
- No Cross Conduction Between Two Inputs
- Reverse Current Blocking when Disabled
- Operating Temperature Range: -40 to 85 °C
- HBM: 6 kV, CDM: 2 kV
- 0.97 mm x 1.47 mm x 0.55 mm, 6 Bumps
Wafer Level Chip Scale Package

APPLICATIONS

- Wearable/IoT Devices
- Portable Devices
- PMIC Input Protection
- Telecommunication

PACKAGE

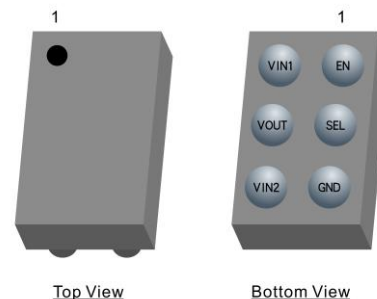

0.97mm x 1.47mm x 0.55mm, 0.5mm pitch

APPLICATION DIAGRAM

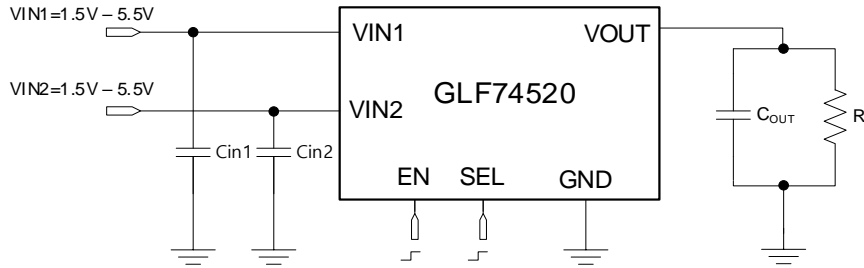

FUNCTIONAL BLOCK DIAGRAM

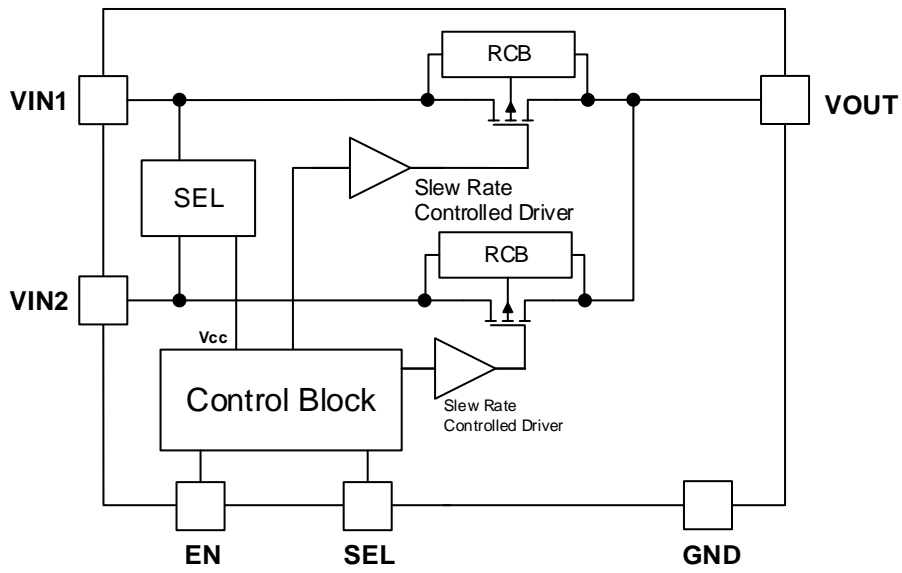
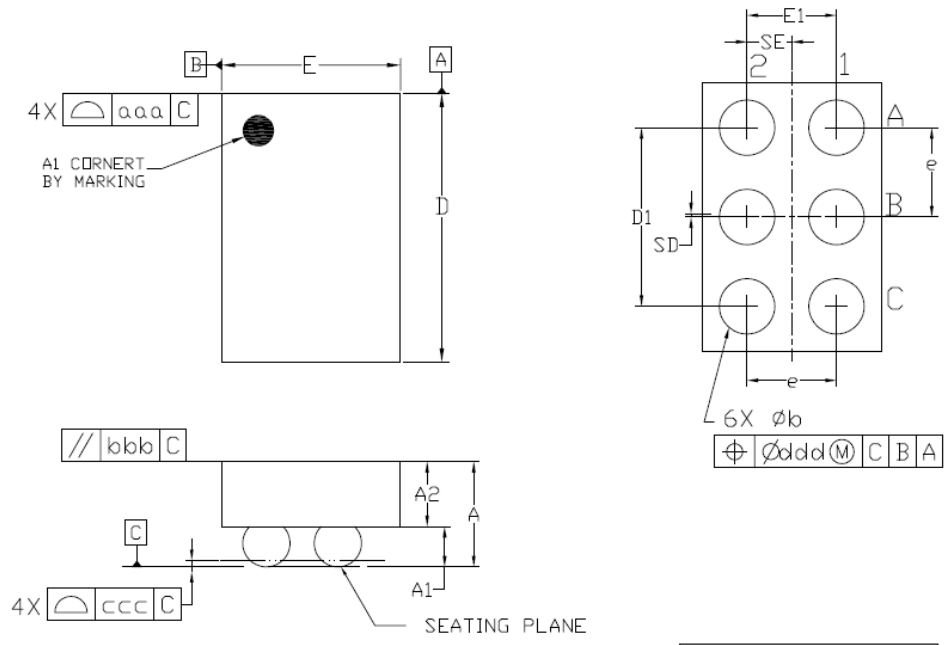

Figure 1. Functional Block Diagram

PACKAGE OUTLINE



Dimensional Ref.			
REF.	Min.	Nom.	Max.
A	0.500	0.550	0.600
A1	0.225	0.250	0.275
A2	0.275	0.300	0.325
D	1.460	1.470	1.485
E	0.960	0.970	0.985
D1	0.950	1.000	1.050
E1	0.450	0.500	0.550
b	0.260	0.310	0.360
e	0.500 BSC		
SD	0.000 BSC		
SE	0.250 BSC		
Tol. of Form&Position			
aaa	0.10		
bbb	0.10		
ccc	0.05		
ddd	0.05		

Notes

1. ALL DIMENSIONS ARE IN MILLIMETERS (ANGLES IN DEGREES).
2. DIMENSIONING AND TOLERANCING PER ANSI Y14.5M-1994.

单击下面可查看定价，库存，交付和生命周期等信息

[>>GLF](#)