

DESCRIPTION

The GLF1100 is an ultra-efficiency, 2 A rated, Load Switch with integrated slew rate control. The best in class efficiency makes it an ideal chose for use in IoT, mobile, and wearable electronics.

The GLF1100 features ultra-efficient I_QSmart™ technology that supports the lowest quiescent current (I_Q) and shutdown current (I_{SD}) in the industry. Low I_Q and I_{SD} solutions help designers to reduce parasitic leakage current, improve system efficiency, and increase battery lifetime.

The GLF1100 integrated slew rate control can also enhance system reliability by mitigating bus voltage swings during switching events. Where uncontrolled switches can generate high inrush currents that result in voltage droop and/or bus reset events, the GLF slew rate control specifically limits inrush currents during turn-on to minimize voltage droop.

GLF1100 Load Switch devices support an industry leading wide input voltage range and helps to improve operating life and system robustness. Furthermore, one device can be used in multiple voltage rail applications which helps to simplify inventory management and reduce operating cost.

FEATURES

- Wide Input Range: 1.1 V to 5.5 V
6 V abs max
- R_{ON} : 82 mΩ Typ @ 5.5 V_{IN}
- I_{OUT} Max: 2 A
- Ultra-Low I_Q: 10 nA Typ @ 5.5 V_{IN}
- Ultra-Low I_{SD}: 25 nA Typ @ 5.5 V_{IN}
- Controlled Rise Time: 2.2 ms at 3.3 V_{IN}
- Internal EN Pull-Down Resistor
- Integrated Output Discharge Switch
- Wide Operating Temperature Range:
-40 °C ~ 85 °C
- HBM: 6 kV, CDM: 2 kV

APPLICATIONS

- Telecommunication Module
- Low Power Subsystem
- Mobile Devices

PACKAGE

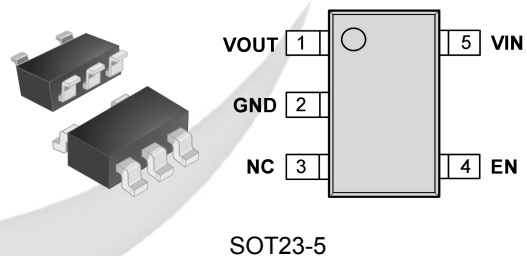

PACKAGE OUTLINE

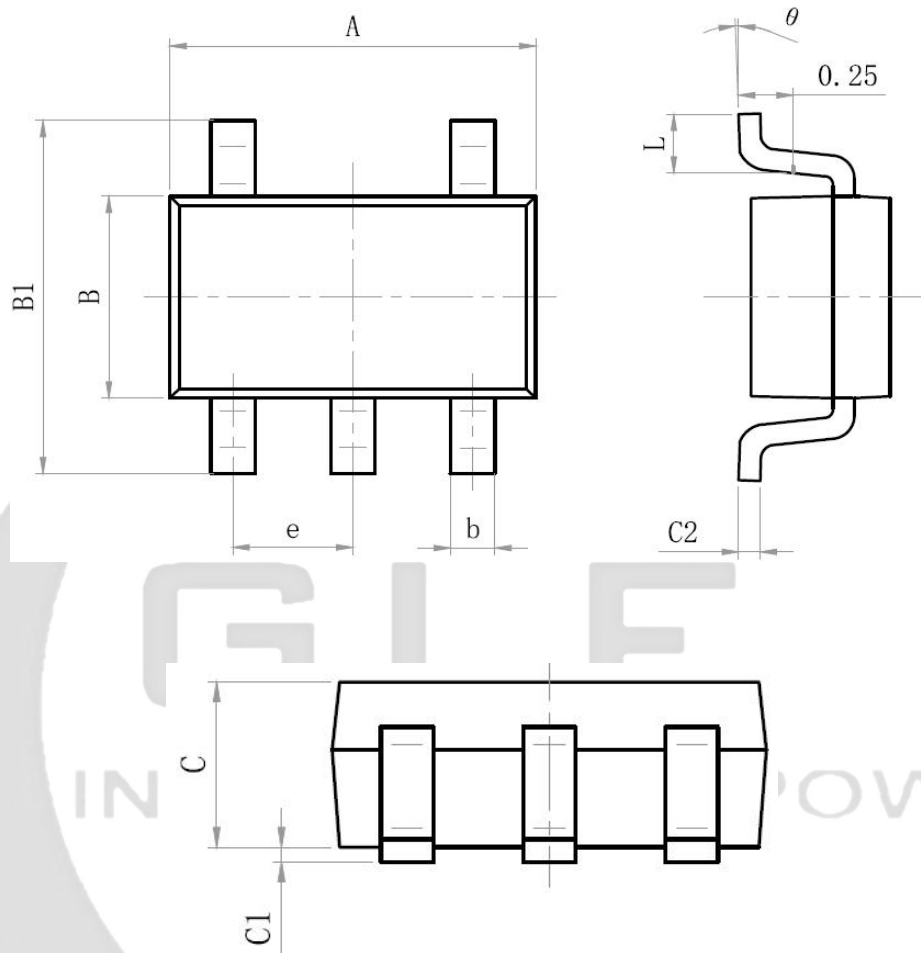

Size Mark	Min (mm)	Max (mm)	Size Mark	Min (mm)	Max (mm)
A	2.82	3.02	C	1.05	1.15
e	0.95 (BSC)		C1	0.03	0.15
b	0.28	0.45	C2	0.12	0.23
B	1.50	1.70	L	0.35	0.55
B1	2.60	3.00	θ	0°	8°

TAPE AND REEL INFORMATION

REEL DIMENSIONS

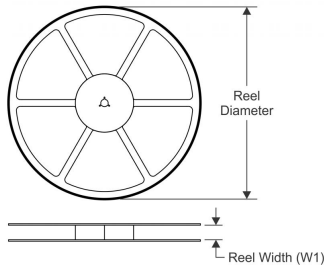

QUADRANT ASSIGNMENTS PIN 1 ORIENTATION TAPE

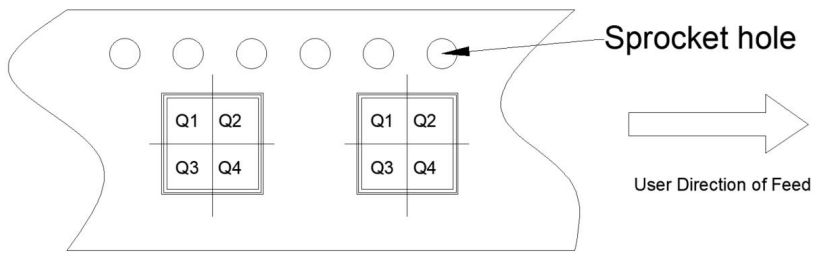

TAPE DIMENSIONS

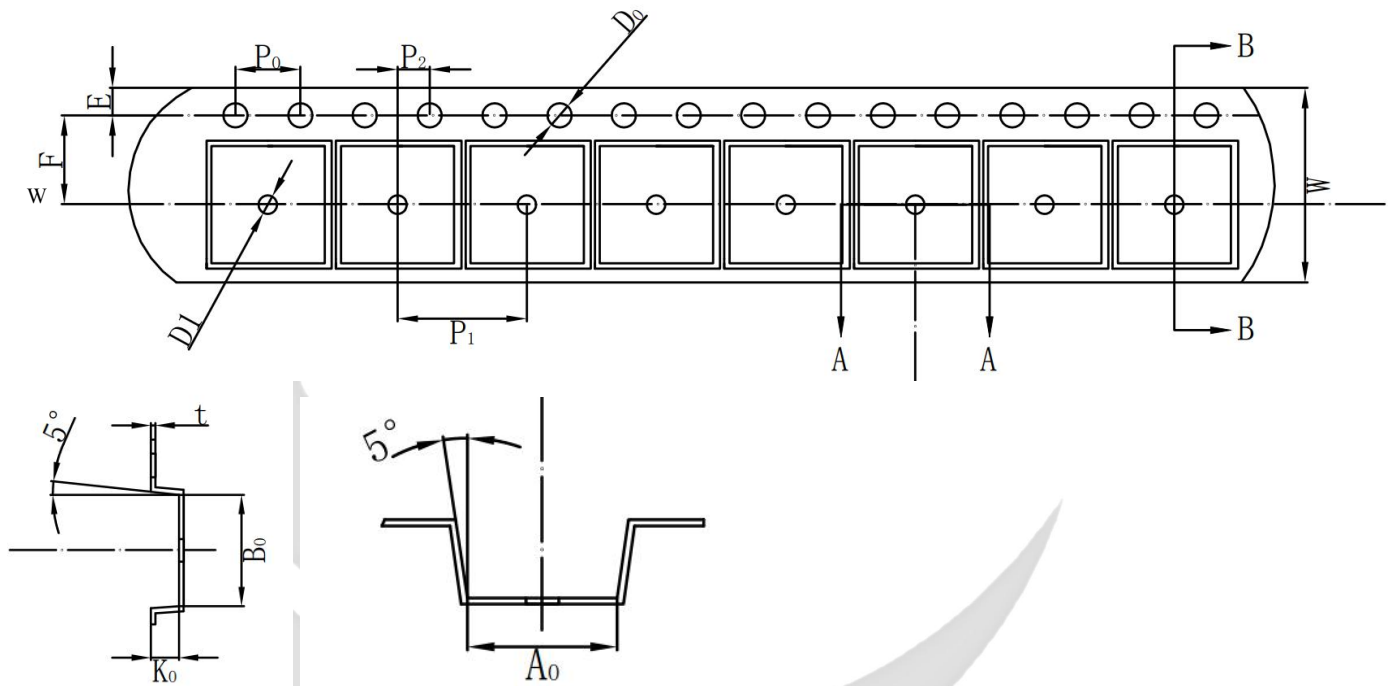

Device	Package	Pins	SPQ	Reel Diameter(mm)	Reel Width W1	A0	B0	K0	P1	W	Pin1
GLF1100-T1G7	SOT23-5	5	3000	178	9	3.25	3.30	1.38	4	8	Q3

Remark:

A0: Dimension designed to accommodate the component width

B0: Dimension designed to accommodate the component length

C0: Dimension designed to accommodate the component thickness

W: Overall width of the carrier tape

P1: Pitch between successive cavity centers

单击下面可查看定价，库存，交付和生命周期等信息

[>>GLF\(杰夫微\)](#)