

Product Specification

DESCRIPTION

The GLF73915 is an I_QSmart™ ultra-efficient, full battery protection IC with an accurate over charge voltage, over discharge voltage, shipping mode, over charge current, and short circuit protection for lithium-Ion/Polymer battery safety.

The over charge and discharge voltage protections keep a rechargeable battery working within the desired safe operating condition. When the battery is charged past the over voltage detection level, the GLF73915 charging switch opens in a preset delay time. As the battery voltage decreases below the over discharge detection voltage level, the GLF73915 discharging switch is turned off immediately to cut off the battery power rail, consuming an ultra-low leakage current (I_{SD}) to save the battery. In addition, when the load current reaches the I_{SC} short circuit protection level, the GLF73915 is turned off and will maintain the off state to avoid any serious damage to system. The short circuit delay time avoids any false trigger which might open the switch.

The GLF73915 provides a shipping mode pin to prevent smart devices with a non-removable battery from discharging during the shipping period. When a charged battery cell is connected the GLF73915 remains in the off state and consumes an ultra-low leakage current (I_{SD}) until the V_{ON} voltage is applied to VOUT pin. Note that the GLF73915 is activated only by a V_{ON} voltage from a charger output.

FEATURES

- Over Charge Detection, V_{OC} : 4.35 V_{BAT}
- Over Discharge Detection, V_{OD} : 2.80 V_{BAT}
- I_{OC}, Over Charge Current Detection
- Load Short Circuit Protection with Delay Time to avoid a false trigger
- Activated by Applying V_{ON} to the VOUT Pin from Charger
- 1.5 A Continuous Charging Current Capability from VOUT to VBAT Pin
- Low R_{ON} : 57 mΩ Typ. @ 3.6 V_{BAT}
- Quiescent Current, I_Q = 900 nA Typ. @ 3.6 V_{BAT}
- Shutdown Current
 - I_{SD} = 7 nA Typ. @ V_{BAT} < V_{OD}
 - I_{SD} = 8 nA Typ. @ V_{BAT} = 3.6 V, Shipping Mode
 - I_{SD} = 9 nA Typ. @ V_{BAT} = 4.2 V, Shipping Mode
- Latch-off at Over Discharge Detection and Short Circuit Protection. Apply V_{ON} to VOUT pin to turn on
- Shipping Mode Implementation
- 0 V Battery Minimum Voltage for Charging
- Reverse Polarity Connection Protection
- Patent Pending Circuit Architecture
- HBM : 8 kV, CDM : 2 kV
- 0.97 mm x 0.97 mm x 0.55 mm Chip Scale Package
4 Bumps, 0.5 mm Pitch

APPLICATIONS

- BLE Wireless Earphone
- Wearables and Smart IoT Devices

PACKAGE

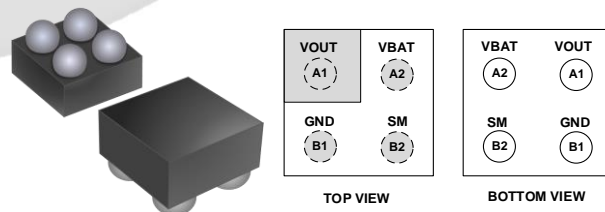

0.97 mm x 0.97 mm x 0.55 mm WLCSP

APPLICATION DIAGRAM

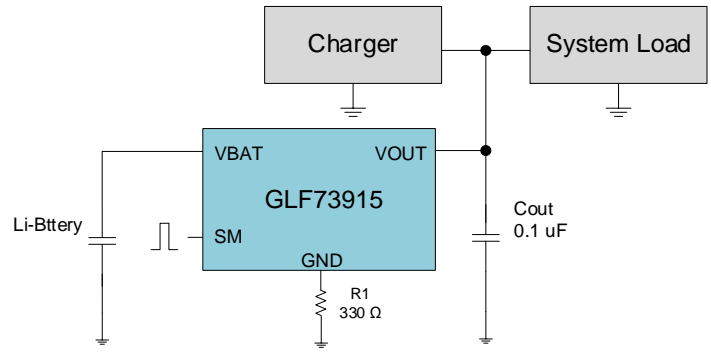

FUNCTIONAL BLOCK DIAGRAM

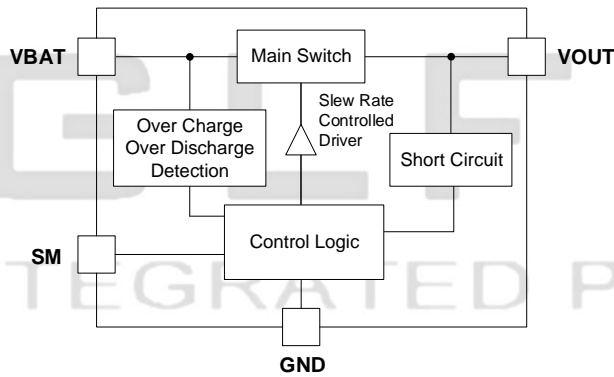
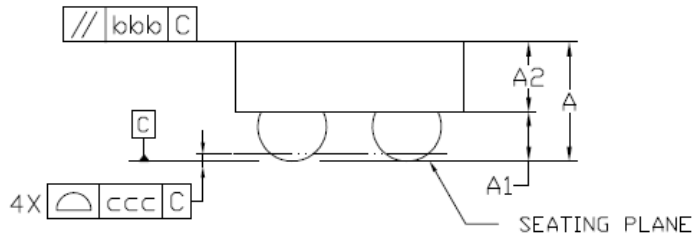
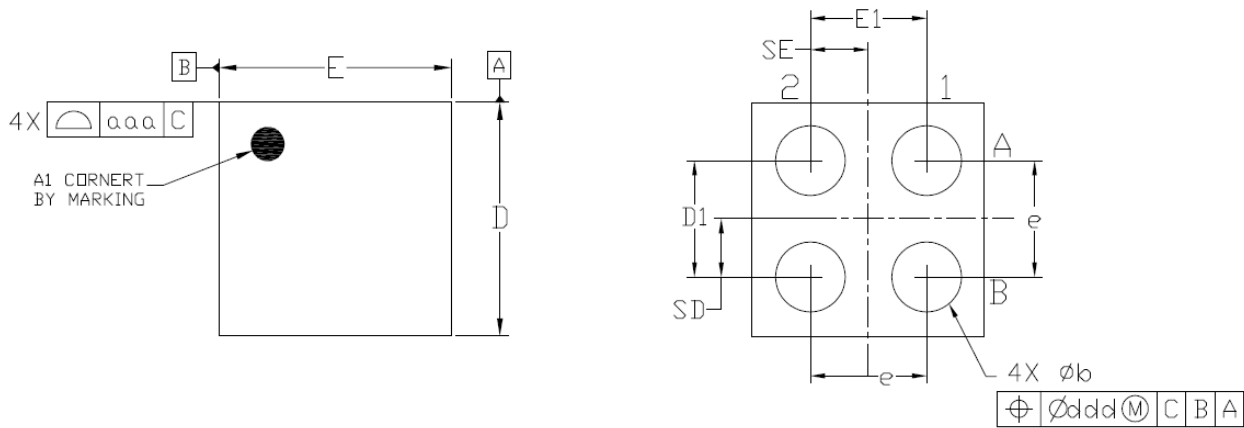

Figure 1. Functional Block Diagram

PACKAGE OUTLINE



Dimensional Ref.			
REF.	Min.	Nom.	Max.
A	0.500	0.550	0.600
A1	0.225	0.250	0.275
A2	0.275	0.300	0.325
D	0.960	0.970	0.985
E	0.960	0.970	0.985
D1	0.450	0.500	0.550
E1	0.450	0.500	0.550
b	0.260	0.310	0.360
e	0.500 BSC		
SD	0.250 BSC		
SE	0.250 BSC		
Tol. of Form&Position			
aaa	0.10		
bbb	0.10		
ccc	0.05		
ddd	0.05		

Notes

1. ALL DIMENSIONS ARE IN MILLIMETERS (ANGLES IN DEGREES).
2. DIMENSIONING AND TOLERANCING PER ANSI Y14.5M-1994.

单击下面可查看定价，库存，交付和生命周期等信息

[>>GLF](#)