



Product Summary

$V_{(BR)DSS}$	$R_{DS(on)TYP}$	I_D
-40V	28mΩ@-10V	-7A
	38mΩ@-4.5V	

Feature

- High Cell Density Trenched P-ch MOSFETs
- Excellent $R_{DS(on)}$
- Low Gate Charge

Application

- Power Switching Application
- Hard Switched and High Frequency Circuits
- DC-DC Converter

MARKING:

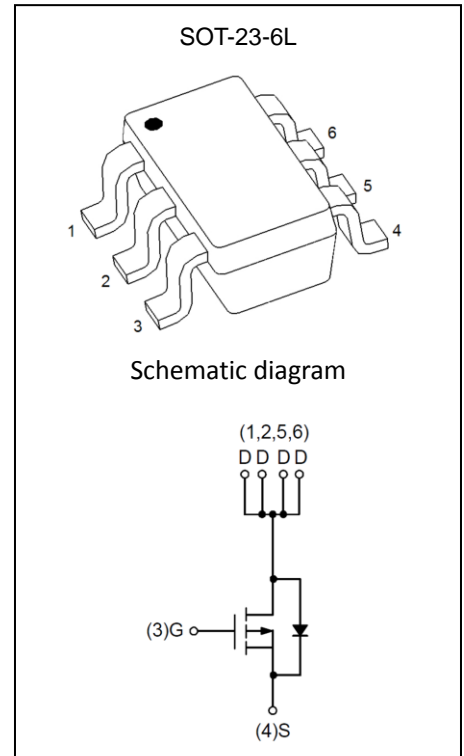
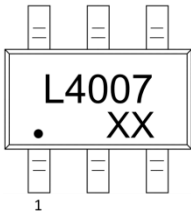

ABSOLUTE MAXIMUM RATINGS ($T_C=25^{\circ}C$ unless otherwise noted)

Parameter	Symbol	Value	Unit
Drain-Source Voltage	V_{DS}	-40	V
Gate-Source Voltage	V_{GS}	± 20	V
Continuous Drain Current ¹	I_D	-7	A
Pulsed Drain Current ²	I_{DM}	-28	A
Single Pulse Avalanche Energy ³	E_{AS}	40	mJ
Avalanche Current	I_{AS}	-27	A
Power Dissipation ⁴	P_D	1.1	W
Thermal Resistance from Junction to Ambient ¹	$R_{\theta JA}$	110	$^{\circ}C/W$
Junction Temperature	T_J	150	$^{\circ}C$
Storage Temperature	T_{STG}	-55~ +150	$^{\circ}C$

MOSFET ELECTRICAL CHARACTERISTICS (T_J=25°C unless otherwise noted)

Parameter	Symbol	Test Condition	Min	Type	Max	Unit
Static Characteristics						
Drain-source breakdown voltage	V _{(BR)DSS}	V _{GS} = 0V, I _D = -250μA	-40			V
Zero gate voltage drain current	I _{DSS}	V _{DS} = -32V, V _{GS} = 0V			-1	μA
Gate-body leakage current	I _{GSS}	V _{GS} = ±20V, V _{DS} = 0V			±100	nA
Gate threshold voltage	V _{GS(th)}	V _{DS} = V _{GS} , I _D = -250μA	-1.2	-1.5	-2.5	V
Drain-source on-resistance ²	R _{DS(on)}	V _{GS} = -10V, I _D = -5A		28	35	mΩ
		V _{GS} = -4.5V, I _D = -4A		38	50	
Forward transconductance	g _{FS}	V _{DS} = -5V, I _D = -8A		12		S
Dynamic characteristics						
Input capacitance	C _{iss}	V _{DS} = -15V, V _{GS} = 0V, f = 1MHz		1415		pF
Output capacitance	C _{oss}			134		
Reverse transfer capacitance	C _{rss}			102		
Switching Characteristics						
Total gate charge @ -4.5V	Q _g	V _{DS} = -15V, V _{GS} = -4.5V, I _D = -1A		11.5		nC
Gate-source charge	Q _{gs}			3.5		
Gate-drain charge	Q _{gd}			3.3		
Turn-on delay time	t _{d(on)}	V _{DD} = -15V, V _{GS} = -10V, R _G = 3.3 Ω, I _D = -1A		22		ns
Turn-on rise time	t _r			15.7		
Turn-off delay time	t _{d(off)}			59		
Turn-off fall time	t _f			5.5		
Diode Characteristics						
Continuous Source Current ^{1,5}	I _S	V _G = V _D = 0V, Force Current			-7	A
Diode Forward Voltage ²	V _{SD}	V _{GS} = 0V, I _S = -1A, T _J = 25°C			-1.2	V

Notes:

1. The data tested by surface mounted on a 1 inch² FR-4 board with 2OZ copper.
2. The data tested by pulsed, pulse width ≤ 300μs, duty cycle ≤ 2%
3. The E_{AS} data shows Max. rating. The test condition is V_{DD} = -25V, V_{GS} = -10V, L = 0.1mH, I_{AS} = -27A
4. The power dissipation is limited by 150°C junction temperature
5. The data is theoretically the same as I_D and I_{DM}, in real applications, should be limited by total power dissipation.

Typical Electrical and Thermal Characteristics

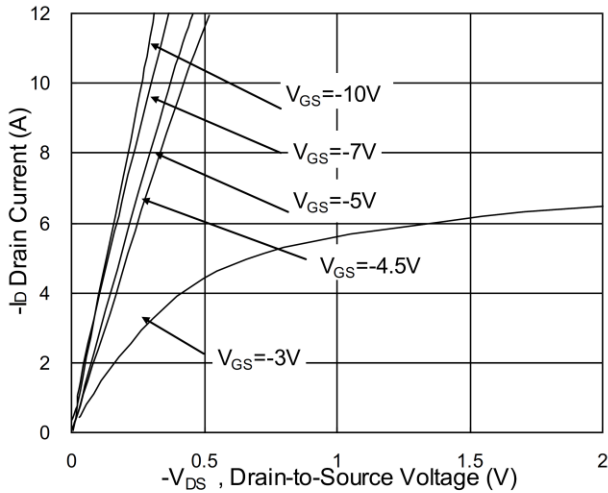

Fig.1 Typical Output Characteristics

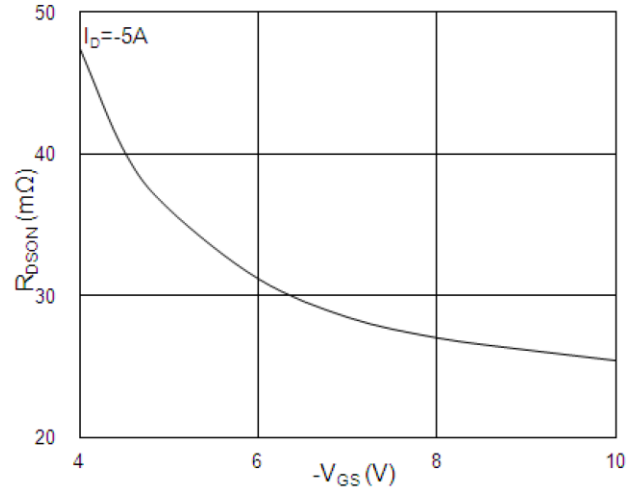

Fig.2 On-Resistance vs. Gate-Source Voltage

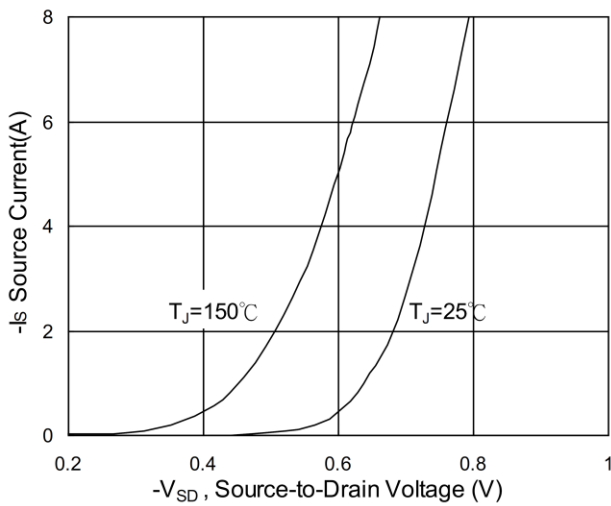

Fig.3 Forward Characteristics of Reverse

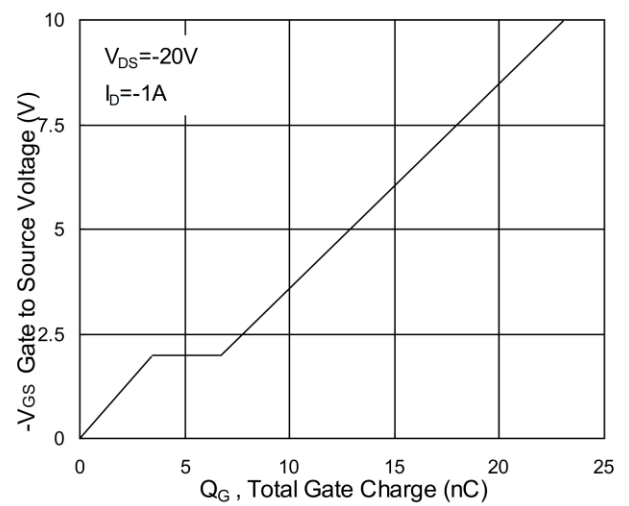

Fig.4 Gate Charge Characteristics

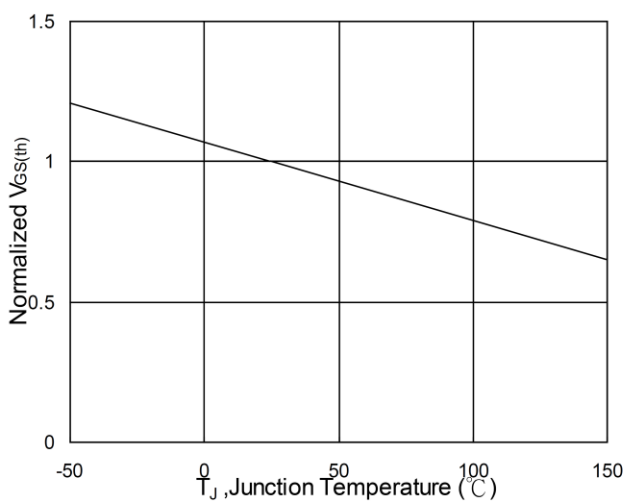

Fig.5 Normalized V_{GS(th)} vs. T_J

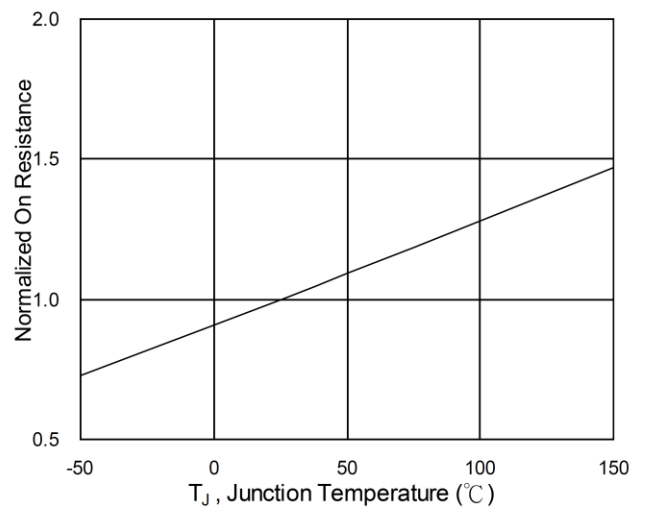

Fig.6 Normalized R_{DS(on)} vs. T_J

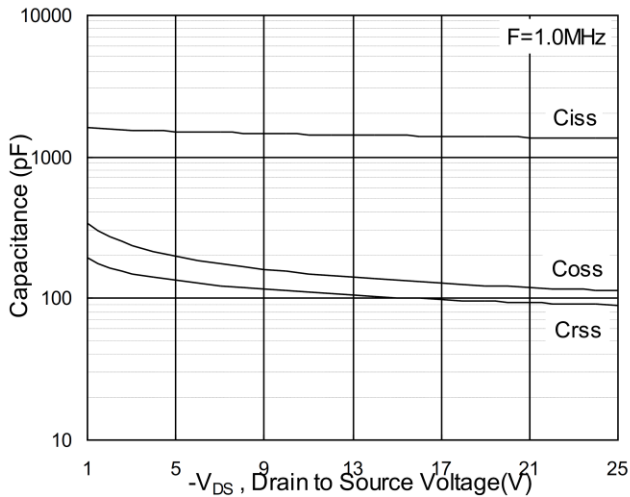

Fig.7 Capacitance

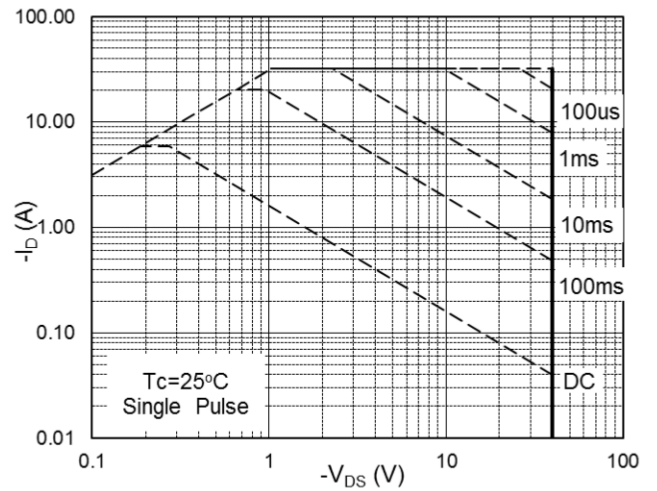

Fig.8 Safe Operating Area

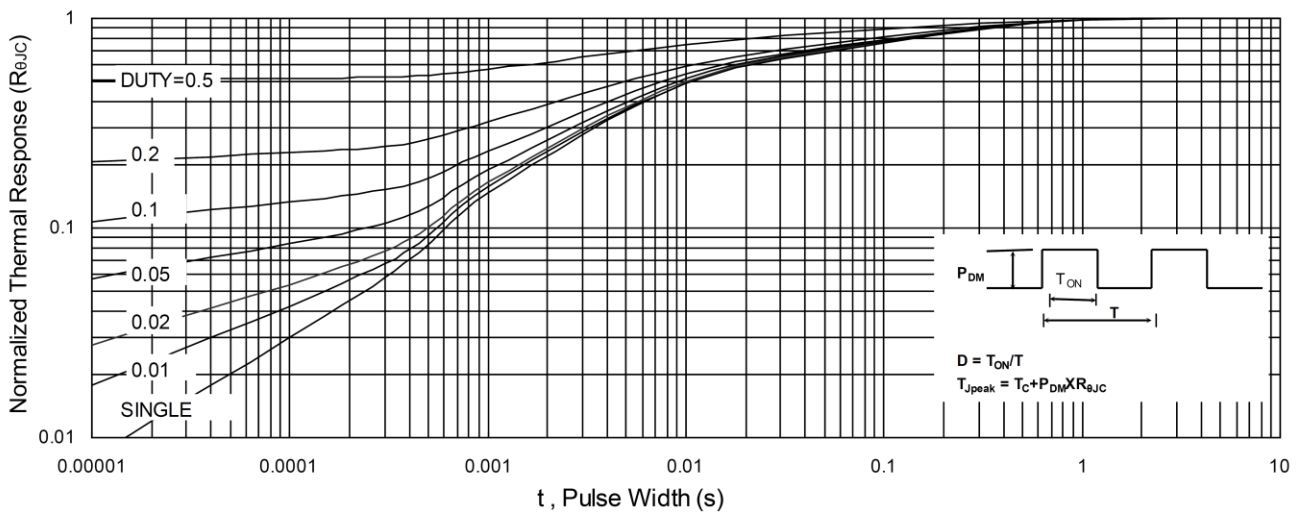
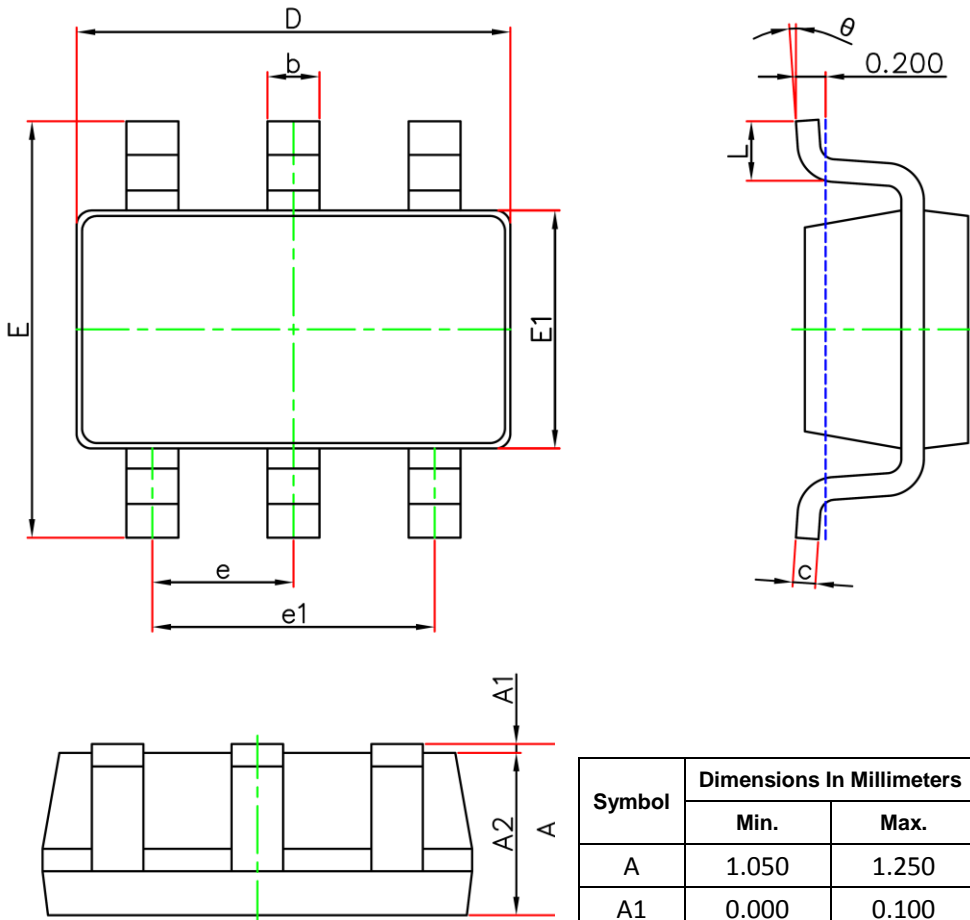

Fig.9 Normalized Maximum Transient Thermal Impedance

SOT-23-6L Package Information



Symbol	Dimensions In Millimeters		Dimensions In Inches	
	Min.	Max.	Min.	Max.
A	1.050	1.250	0.041	0.049
A1	0.000	0.100	0.000	0.004
A2	1.050	1.150	0.041	0.045
b	0.300	0.500	0.012	0.020
c	0.100	0.200	0.004	0.008
D	2.820	3.020	0.111	0.119
E1	1.500	1.700	0.059	0.067
E	2.650	2.950	0.104	0.116
e	0.950(BSC)		0.037(BSC)	
e1	1.800	2.000	0.071	0.079
L	0.300	0.600	0.012	0.024
θ	0°	8°	0°	8°

SOT-23-6L Tape and Reel

SOT-23-6L Embossed Carrier Tape

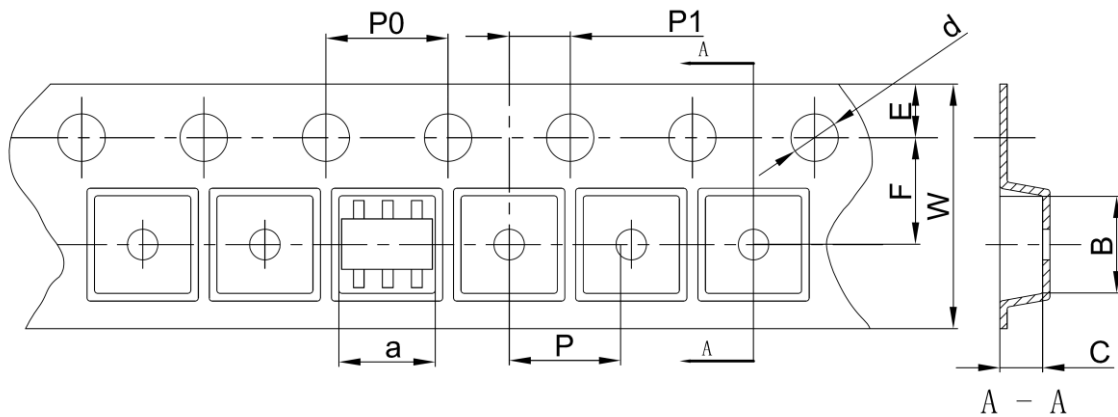

Dimensions are in millimeter										
Pkg type	a	B	C	d	E	F	P0	P	P1	W
SOT-23-6L	3.17	3.23	1.37	Φ1.55	1.75	3.50	4.00	4.00	2.00	8.00

SOT-23-6L Tape Leader and Trailer

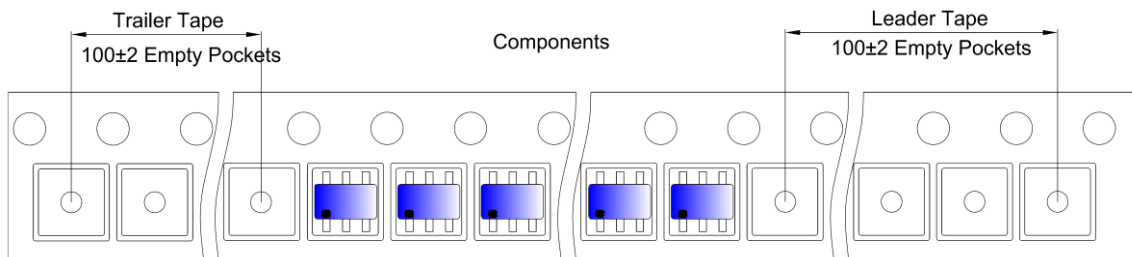

SOT-23-6L Reel

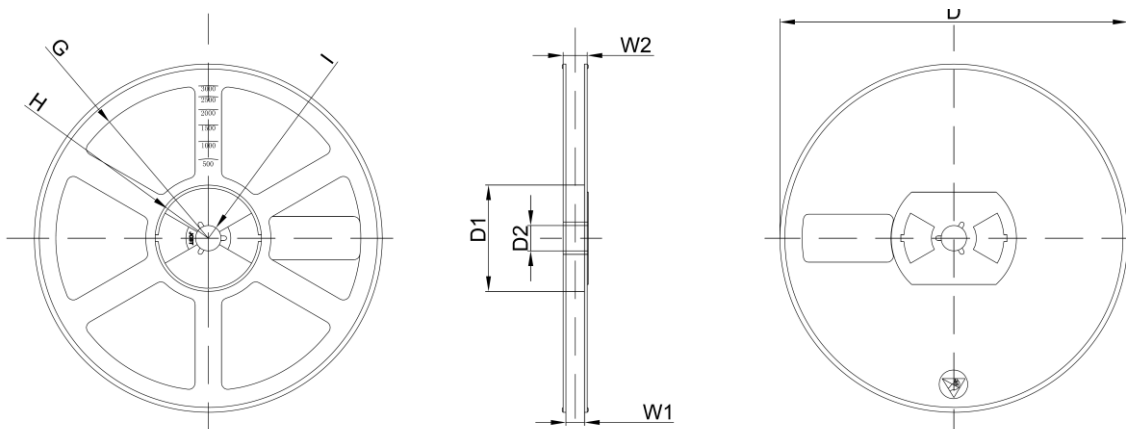

Dimensions are in millimeter								
Reel Option	D	D1	D2	G	H	I	W1	W2
7` Dia	Φ180.00	60.00	13.00	R78.00	R25.60	R6.50	9.50	12.30

Reel	Reel Size	Box	Box Size(mm)	Carton	Carton Size(mm)	G.W.(kg)
3000pcs	7 inch	30,000pcs	203x203x195	120,000pcs	438x438x220	

单击下面可查看定价，库存，交付和生命周期等信息

[>>GP\(格瑞宝\)](#)