

### Product Summary

$V_{(BR)DSS}$	$R_{DS(on)TYP}$	$I_D$
-12V	19mΩ@-4.5V	-6A
	21mΩ@-3.7V	
	27mΩ@-2.5V	
	35mΩ@-1.8V	
	50mΩ@-1.5V	

### Feature

- TrenchFET Power MOSFET
- Excellent  $R_{DS(on)}$  and Low Gate Charge

### Application

- DC/DC Converter
- Load Switch for Portable Devices
- Battery Switch

### MARKING:

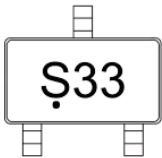

### ABSOLUTE MAXIMUM RATINGS ( $T_a=25^{\circ}C$ unless otherwise noted)

Parameter	Symbol	Value	Unit
Drain - Source Voltage	$V_{DS}$	-12	V
Gate - Source Voltage	$V_{GS}$	±8	V
Continuous Drain Current <sup>1,5</sup>	$I_D$	-6	A
Pulsed Drain Current <sup>2</sup>	$I_{DM}$	-20	A
Power Dissipation <sup>4,5</sup>	$P_D$	1.7	W
Thermal Resistance from Junction to Ambient <sup>5</sup>	$R_{\theta JA}$	73.5	°C/W
Junction and Storage Temperature Range	$T_J, T_{STG}$	-55~ +150	°C

### SOT-23-3L

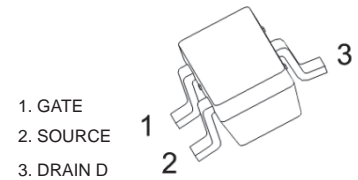

1. GATE
2. SOURCE
3. DRAIN D

### Schematic diagram

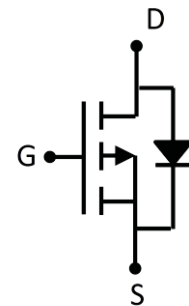

**MOSFET ELECTRICAL CHARACTERISTICS(T<sub>a</sub>=25°C unless otherwise noted)**

Parameter	Symbol	Test Condition	Min	Type	Max	Unit
<b>Off Characteristics</b>						
Drain-source breakdown voltage	V <sub>(BR)DSS</sub>	V <sub>GS</sub> = 0V, I <sub>D</sub> = -250μA	-12			V
Zero gate voltage drain current	I <sub>DSS</sub>	V <sub>DS</sub> = -12V, V <sub>GS</sub> = 0V			-1	μA
Gate-body leakage current	I <sub>GSS</sub>	V <sub>GS</sub> = ±8V, V <sub>DS</sub> = 0V			±0.1	μA
<b>On Characteristics</b>						
Gate threshold voltage <sup>3</sup>	V <sub>GS(th)</sub>	V <sub>DS</sub> = V <sub>GS</sub> , I <sub>D</sub> = -250μA	-0.4	-0.65	-1	V
Drain-source on-resistance <sup>3</sup>	R <sub>DS(on)</sub>	V <sub>GS</sub> = -4.5V, I <sub>D</sub> = -5A		19	25	mΩ
		V <sub>GS</sub> = -3.7V, I <sub>D</sub> = -4.6A		21	32	
		V <sub>GS</sub> = -2.5V, I <sub>D</sub> = -4.3A		27	37	
		V <sub>GS</sub> = -1.8V, I <sub>D</sub> = -1A		35	63	
		V <sub>GS</sub> = -1.5V, I <sub>D</sub> = -0.5A		50	150	
Forward tranconductance <sup>3</sup>	g <sub>FS</sub>	V <sub>DS</sub> = -5V, I <sub>D</sub> = -5A	10	14		S
<b>Dynamic Characteristics</b>						
Input Capacitance	C <sub>iss</sub>	V <sub>DS</sub> = -6V, V <sub>GS</sub> = 0V, f = 1MHz		1275		pF
Output Capacitance	C <sub>oss</sub>			255		
Reverse Transfer Capacitance	C <sub>rss</sub>			236		
<b>Switching Characteristics</b>						
Gate resistance	R <sub>g</sub>	f = 1MHz	1.9		19	Ω
Total Gate Charge	Q <sub>g</sub>	V <sub>DS</sub> = -6V, V <sub>GS</sub> = -4.5V, I <sub>D</sub> = -5A		14		nC
Gate-Source Charge	Q <sub>gs</sub>			2.3		
Gate-Drain Charge	Q <sub>gd</sub>			3.6		
Turn-on delay time	t <sub>d(on)</sub>	V <sub>DS</sub> = -6V, V <sub>GS</sub> = -4.5V, I <sub>D</sub> = -4A R <sub>L</sub> = 6Ω, R <sub>g</sub> = 1Ω		26		ns
Turn-on rise time	t <sub>r</sub>			24		
Turn-off delay time	t <sub>d(off)</sub>			45		
Turn-off fall time	t <sub>f</sub>			20		
<b>Source-Drain Diode Characteristics</b>						
Diode forward current	I <sub>S</sub>	T <sub>C</sub> =25°C			-6	A
Diode pulsed forward current	I <sub>SM</sub>				-20	A
Diode Forward voltage <sup>3</sup>	V <sub>SD</sub>	V <sub>GS</sub> = 0V, I <sub>S</sub> = -4A			-1.2	V
Diode reverse recovery time	t <sub>rr</sub>	I <sub>F</sub> = -4A, dI/dt = 100A/μs		24	48	ns
Diode reverse recovery charge	Q <sub>rr</sub>				8	16

Notes :

- 1.The maximum current rating is limited by package.
- 2.Pulse Test : Pulse Width ≤ 10μs, duty cycle ≤ 1%.
- 3.Pulse Test : Pulse Width ≤ 300μs, duty cycle ≤ 2%.
- 4.The power dissipation P<sub>D</sub> is limited by T<sub>J(MAX)</sub> = 150°C.
- 5.Device mounted on 1in<sup>2</sup> FR-4 board with 2oz. Copper, in a still air environment with T<sub>A</sub> =25°C.

**Typical Electrical and Thermal Characteristics**

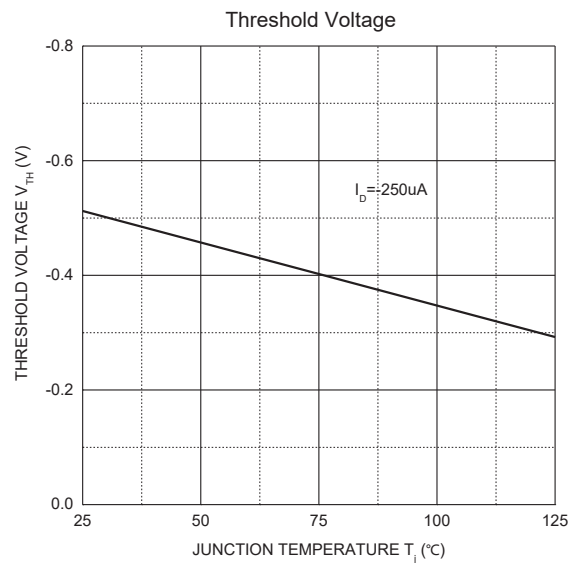
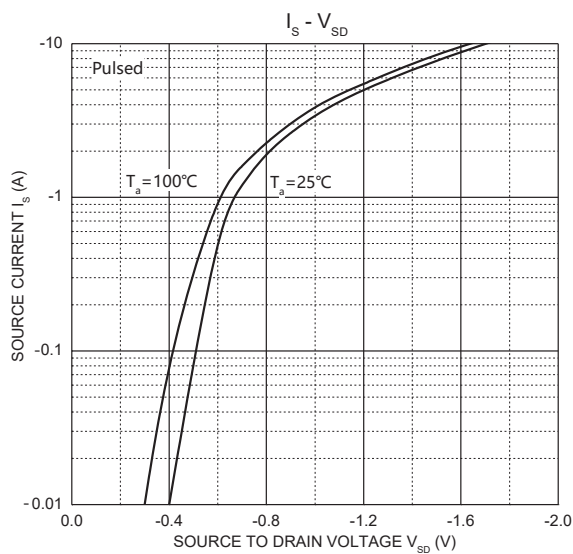
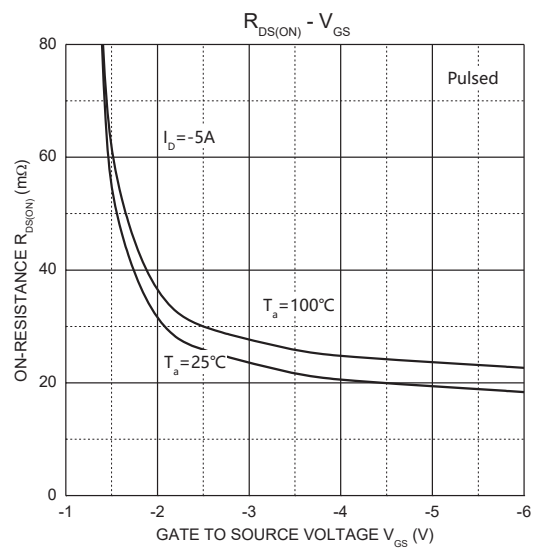
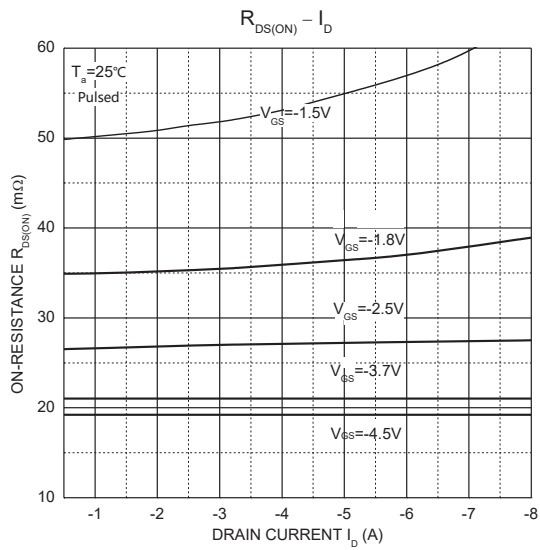
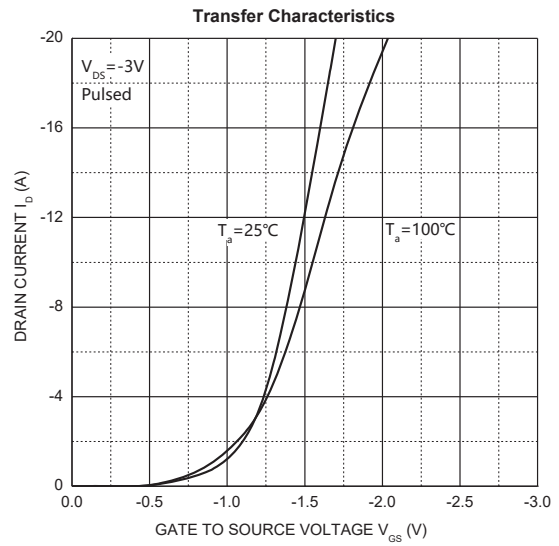
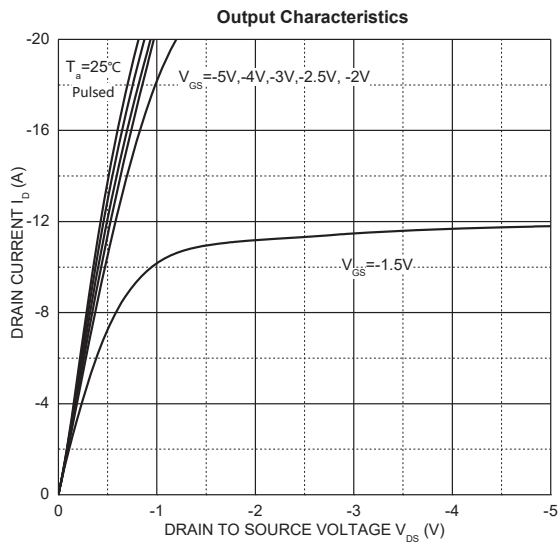

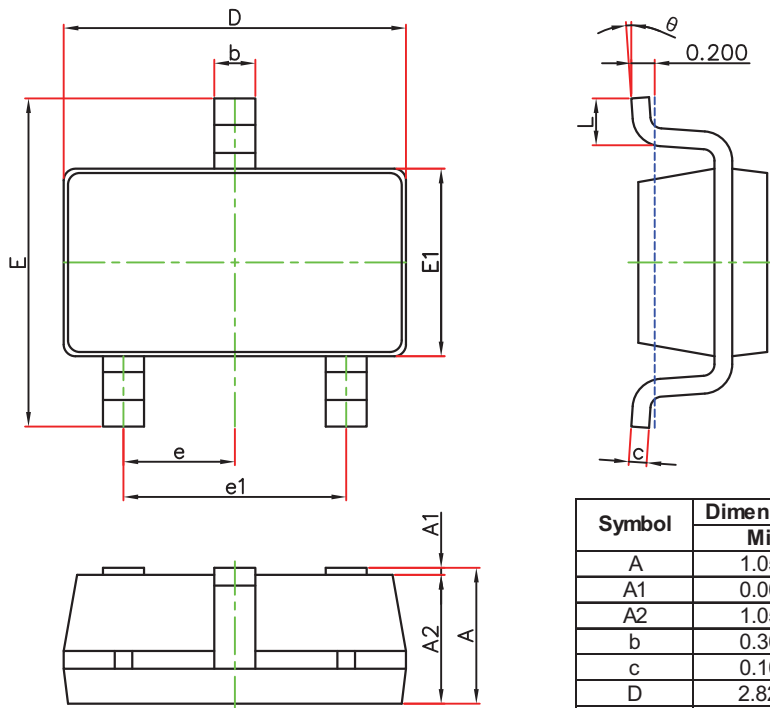
**SOT-23-3L Package Outline Dimensions**

Symbol	Dimensions In Millimeters		Dimensions In Inches	
	Min.	Max.	Min.	Max.
A	1.050	1.250	0.041	0.049
A1	0.000	0.100	0.000	0.004
A2	1.050	1.150	0.041	0.045
b	0.300	0.500	0.012	0.020
c	0.100	0.200	0.004	0.008
D	2.820	3.020	0.111	0.119
E1	1.500	1.700	0.059	0.067
E	2.650	2.950	0.104	0.116
e	0.950(BSC)		0.037(BSC)	
e1	1.800	2.000	0.071	0.079
L	0.300	0.600	0.012	0.024
θ	0°	8°	0°	8°

**SOT-23-3L Tape and Reel**

**SOT-23-3L Embossed Carrier Tape**

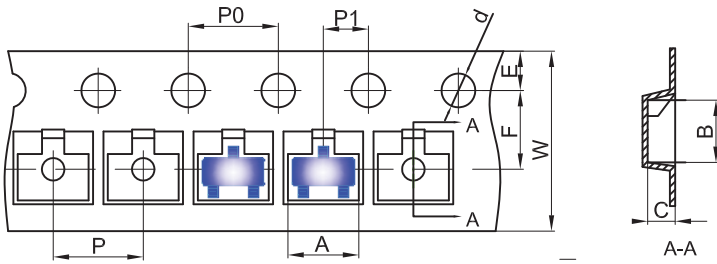

Dimensions are in millimeter										
Pkg type	A	B	C	d	E	F	P0	P	P1	W
SOT-23-3L	3.18	3.28	1.32	Ø1.50	1.75	3.50	4.00	4.00	2.00	8.00

**SOT-23-3L Tape Leader and Trailer**

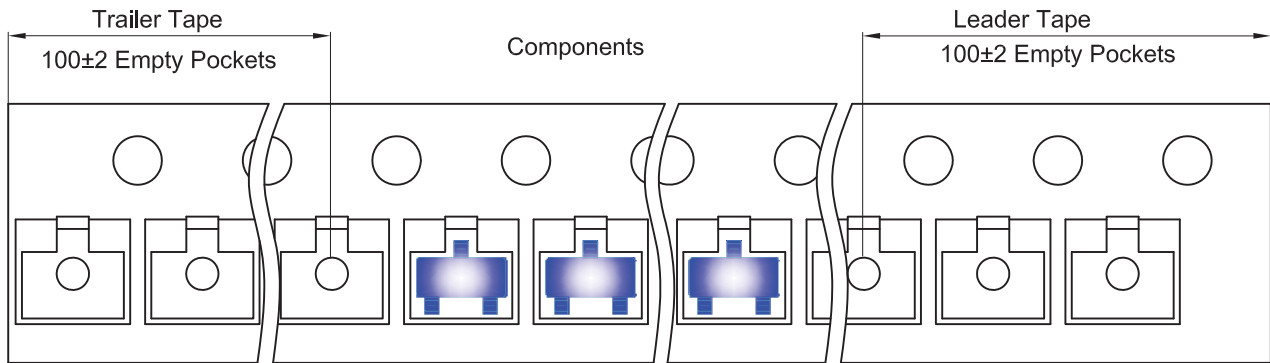

**SOT-23-3L Reel**

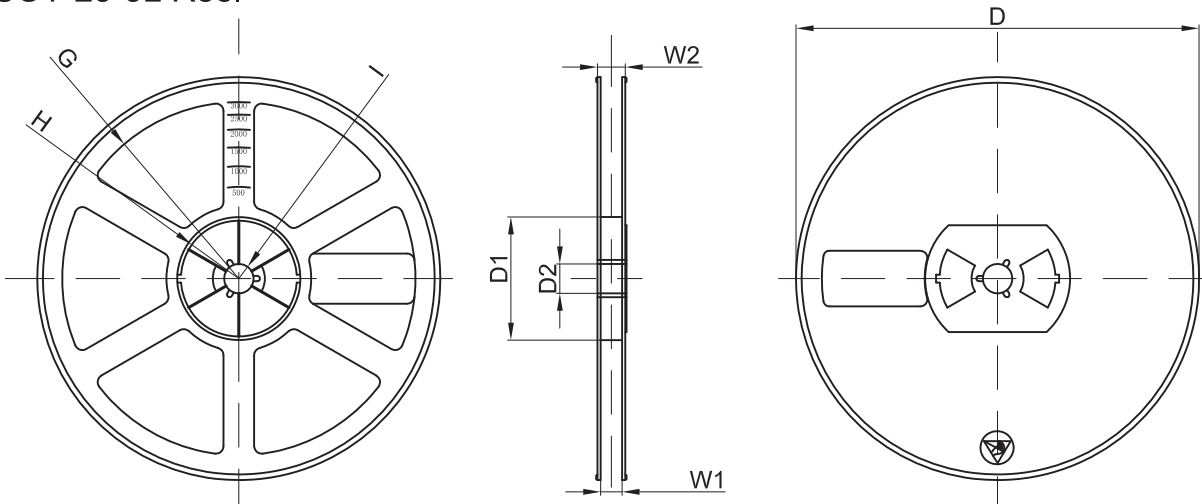

Dimensions are in millimeter								
Reel Option	D	D1	D2	G	H	I	W1	W2
7" Dia	Ø180.00	60.00	13.00	R78.00	R25.60	R6.50	9.50	13.10

REEL	Reel Size	Box	Box Size(mm)	Carton	Carton Size(mm)	G.W.(kg)
3000 pcs	7 inch	30,000 pcs	203×203×195	120,000 pcs	438×438×220	

单击下面可查看定价，库存，交付和生命周期等信息

[>>GP\(格瑞宝\)](#)