



Product Summary

$V_{(BR)DSS}$	$R_{DS(on)TYP}$	I_D
30V	19mΩ@10V	6A
	27mΩ@4.5V	
-30V	29mΩ@-10V	-5A
	40mΩ@-4.5V	

Feature

- Trench Technology Power MOSFET
- Low $R_{DS(ON)}$
- Low Gate Charge

Application

- Load Switch
- DC/DC Converter

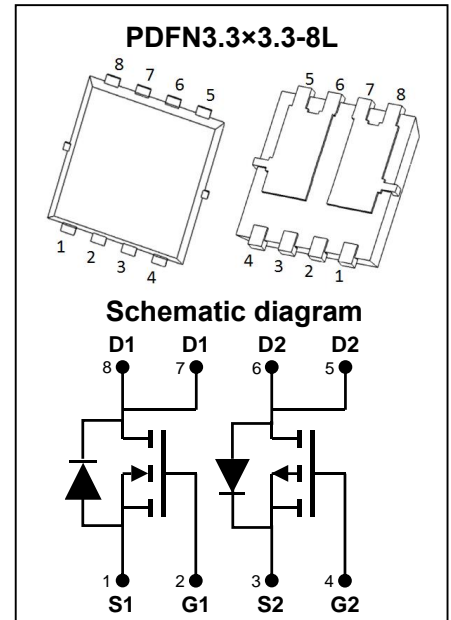

MARKING:



ABSOLUTE MAXIMUM RATINGS ($T_A = 25^\circ\text{C}$ unless otherwise noted)

Parameter	Symbol	Value	Value	Unit
Drain - Source Voltage	V_{DS}	30	-30	V
Gate - Source Voltage	V_{GS}	± 20	± 20	V
Continuous Drain Current ^{1,5}	I_D	6	-5	A
Pulsed Drain Current ²	I_{DM}	24	-20	A
Power Dissipation ⁴	P_D	30	30	W
Thermal Resistance from Junction to Ambient ⁵	$R_{\theta JA}$	83	83	$^\circ\text{C/W}$
Thermal Resistance from Junction to Case	$R_{\theta JC}$	4.2	4.2	$^\circ\text{C/W}$
Junction Temperature	T_J	150	150	$^\circ\text{C}$
Storage Temperature	T_{STG}	-55~ +150	-55~ +150	$^\circ\text{C}$

MOSFET ELECTRICAL CHARACTERISTICS ($T_J = 25^\circ\text{C}$ unless otherwise noted)
NMOS:

Parameter	Symbol	Test Condition	Min	Type	Max	Unit
Off Characteristics						
Drain - Source Breakdown Voltage	$V_{(BR)DSS}$	$V_{GS} = 0V, I_D = 250\mu A$	30			V
Zero Gate Voltage Drain Current	I_{DSS}	$V_{DS} = 30V, V_{GS} = 0V$			1	μA
Gate - Body Leakage Current	I_{GSS}	$V_{GS} = \pm 20V, V_{DS} = 0V$			± 100	nA
On Characteristics³						
Gate Threshold Voltage	$V_{GS(th)}$	$V_{DS} = V_{GS}, I_D = 250\mu A$	1	1.5	3	V
Drain-source On-resistance	$R_{DS(on)}$	$V_{GS} = 10V, I_D = 6.9A$		19	28	m Ω
		$V_{GS} = 4.5V, I_D = 5.0A$		27	42	
Dynamic Characteristics						
Input Capacitance	C_{iss}	$V_{DS} = 15V, V_{GS} = 0V, f = 1MHz$		481		pF
Output Capacitance	C_{oss}			61		
Reverse Transfer Capacitance	C_{rss}			47		
Gate Resistance	R_g	$V_{DS} = 0V, V_{GS} = 0V, f = 1MHz$		3		Ω
Switching Characteristics						
Total Gate Charge	Q_g	$V_{DS} = 15V, V_{GS} = 10V, I_D = 6.9A$		9.8		nC
Gate-source Charge	Q_{gs}			1.8		
Gate-drain Charge	Q_{gd}			1.9		
Turn-on Delay Time	$t_{d(on)}$	$V_{DD} = 15V, V_{GS} = 10V,$ $R_L = 2.2\Omega, R_G = 3\Omega$		3.8		ns
Turn-on Rise Time	t_r			5.2		
Turn-off Delay Time	$t_{d(off)}$			22		
Turn-off Fall Time	t_f			5		
Source - Drain Diode Characteristics						
Diode Forward Voltage ³	V_{SD}	$V_{GS} = 0V, I_S = 1A$			1.2	V

MOSFET ELECTRICAL CHARACTERISTICS ($T_J = 25^\circ\text{C}$ unless otherwise noted)
PMOS:

Parameter	Symbol	Test Condition	Min	Type	Max	Unit
Off Characteristics						
Drain - Source Breakdown Voltage	$V_{(BR)DSS}$	$V_{GS} = 0V, I_D = -250\mu A$	-30			V
Zero Gate Voltage Drain Current	I_{DSS}	$V_{DS} = -30V, V_{GS} = 0V$			-1	μA
Gate - Body Leakage Current	I_{GSS}	$V_{GS} = \pm 20V, V_{DS} = 0V$			± 100	nA
On Characteristics³						
Gate Threshold Voltage	$V_{GS(th)}$	$V_{DS} = V_{GS}, I_D = -250\mu A$	-1	-1.5	-3	V
Drain-source On-resistance	$R_{DS(on)}$	$V_{GS} = -10V, I_D = -6.0A$		29	35	m Ω
		$V_{GS} = -4.5V, I_D = -5.0A$		40	58	
Dynamic Characteristics						
Input Capacitance	C_{iss}	$V_{DS} = -15V, V_{GS} = 0V, f = 1MHz$		785		pF
Output Capacitance	C_{oss}			100		
Reverse Transfer Capacitance	C_{rss}			93		
Gate Resistance	R_g	$V_{DS} = 0V, V_{GS} = 0V, f = 1MHz$		19		Ω
Switching Characteristics						
Total Gate Charge	Q_g	$V_{DS} = -15V, V_{GS} = -10V, I_D = -6.0A$		19.8		nC
Gate-source Charge	Q_{gs}			2.8		
Gate-drain Charge	Q_{gd}			3.6		
Turn-on Delay Time	$t_{d(on)}$	$V_{DD} = -15V, V_{GS} = -10V,$ $R_L = 2.7\Omega, R_G = 3\Omega$		8		ns
Turn-on Rise Time	t_r			3		
Turn-off Delay Time	$t_{d(off)}$			21		
Turn-off Fall Time	t_f			13		
Source - Drain Diode Characteristics						
Diode Forward Voltage ³	V_{SD}	$V_{GS} = 0V, I_S = -1A$			1.2	V

Notes :

- 1.The maximum current rating is limited by package.
- 2.Pulse Test : Pulse Width $\leq 10\mu s$, duty cycle $\leq 1\%$.
- 3.Pulse Test : Pulse Width $\leq 300\mu s$, duty cycle $\leq 2\%$.
- 4.The power dissipation P_D is limited by $T_{J(MAX)} = 150^\circ\text{C}$.
- 5.Device mounted on $1in^2$ FR-4 board with 2oz. Copper, in a still air environment with $T_A = 25^\circ\text{C}$.

Typical Characteristics

NMOS:

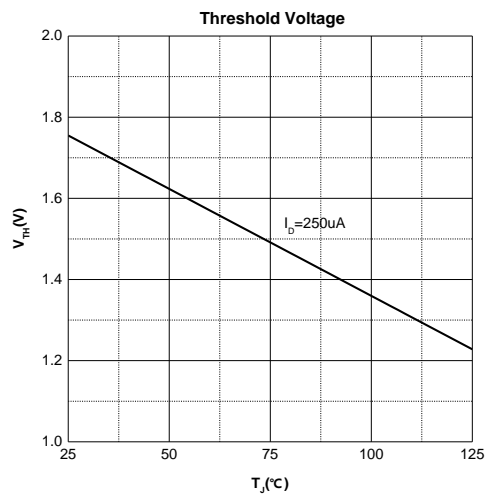
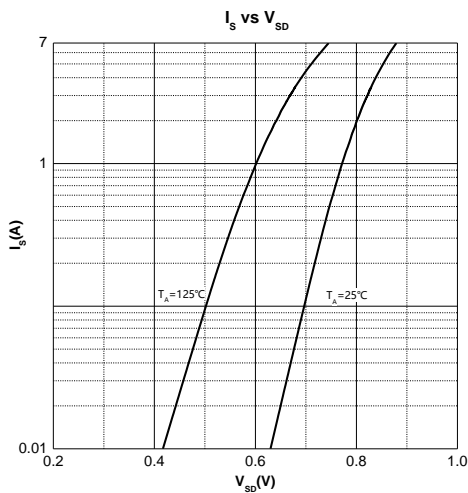
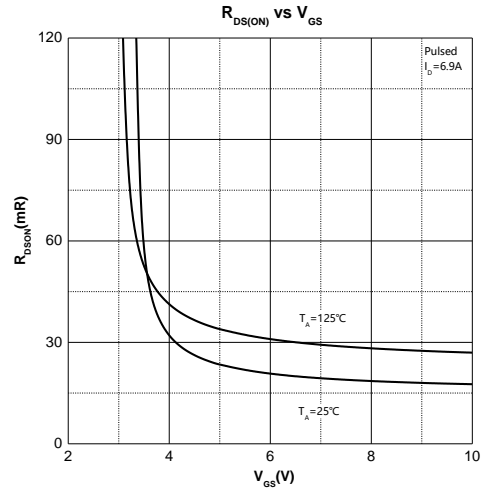
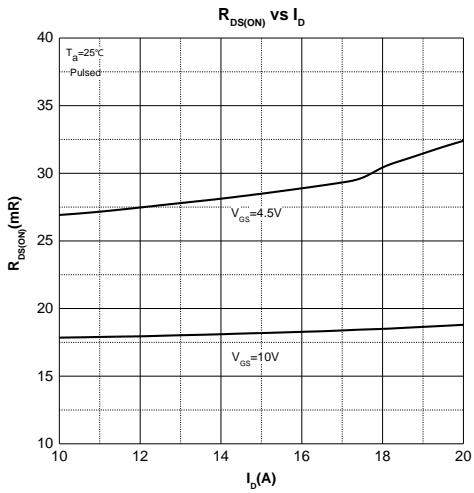
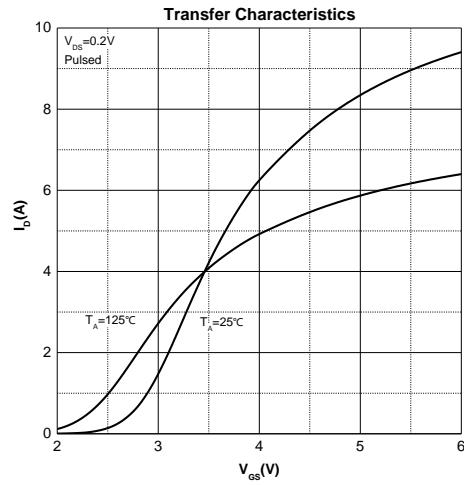
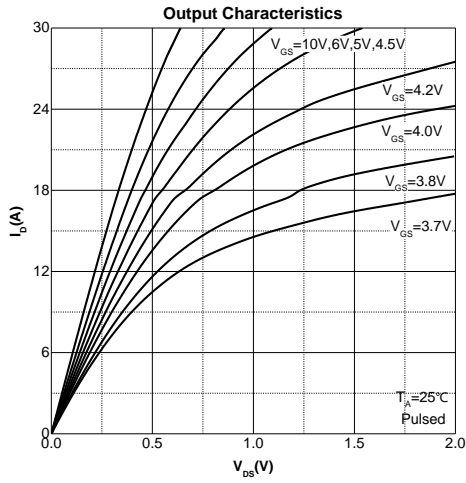

Typical Characteristics

PMOS:

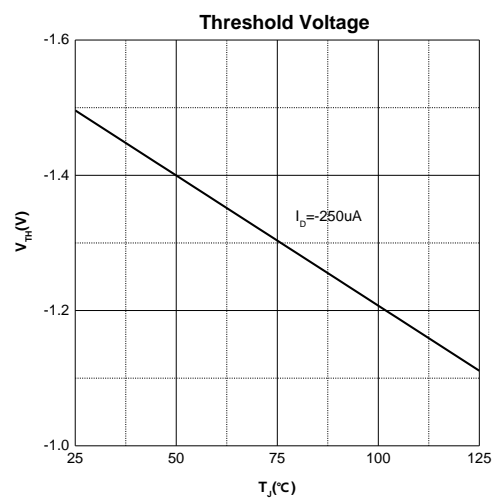
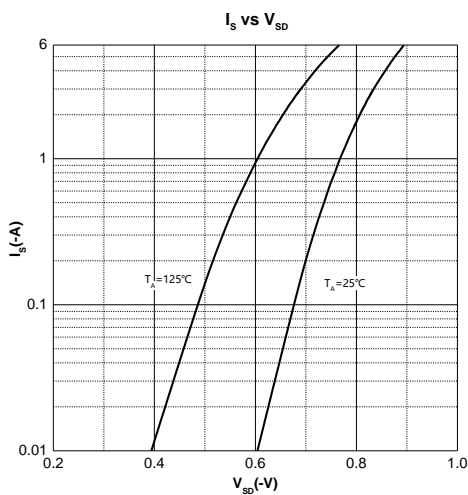
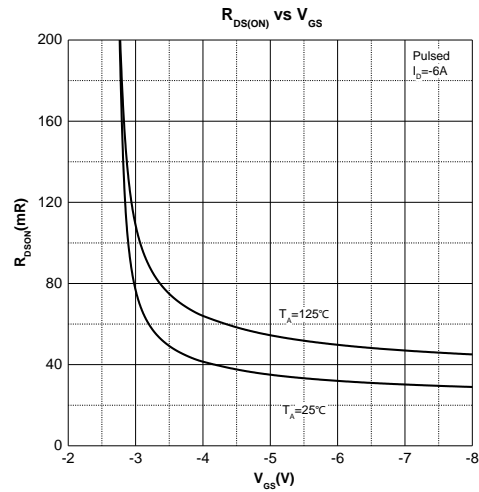
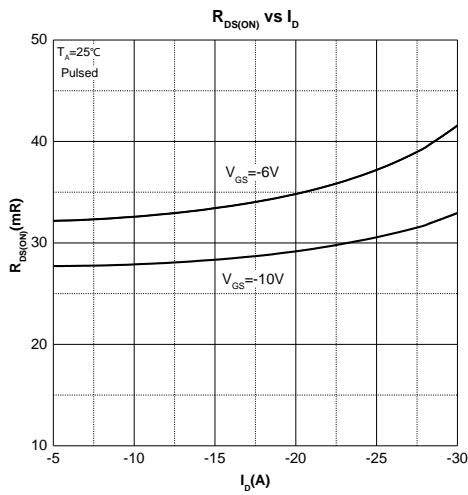
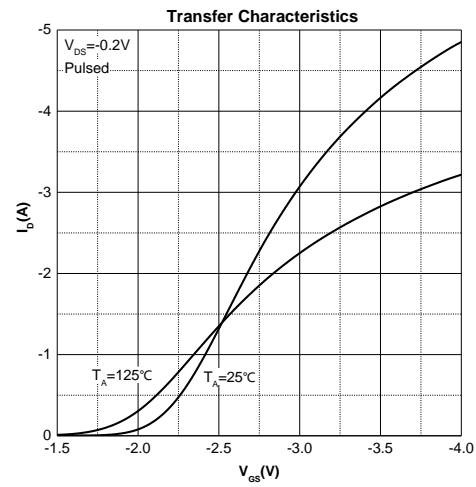
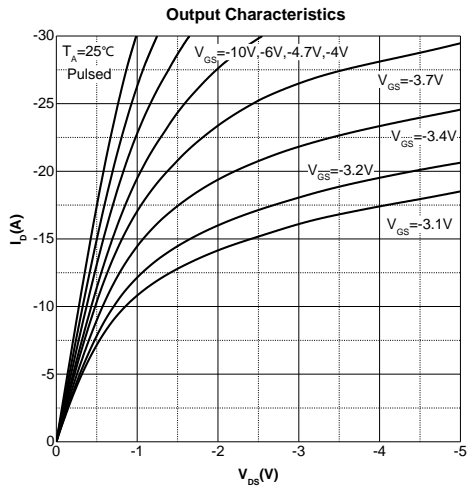

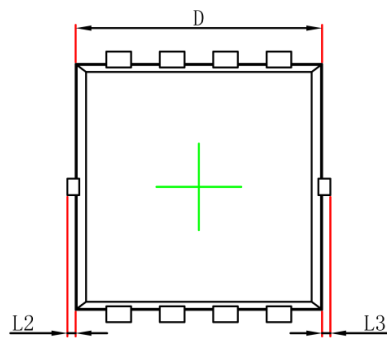
PDFN3.3×3.3-8L Package Information

Top View
[顶视图]

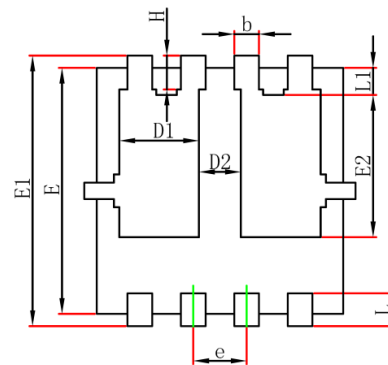

Bottom View
[背视图]

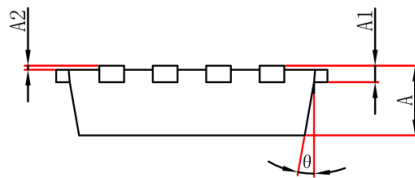

Side View
[侧视图]

Symbol	Dimensions In Millimeters		Dimensions In Inches	
	Min.	Max.	Min.	Max.
A	0.700	0.900	0.028	0.035
A1	0.152REF		0.006REF	
A2	0.000	0.050	0.000	0.002
D	2.900	3.200	0.114	0.126
D1	0.935	1.135	0.037	0.045
D2	0.280	0.480	0.011	0.019
E	2.900	3.200	0.114	0.126
E1	3.150	3.450	0.124	0.136
E2	1.535	1.935	0.060	0.076
b	0.200	0.400	0.008	0.016
e	0.550	0.750	0.022	0.030
L	0.300	0.500	0.012	0.020
L1	0.180	0.480	0.007	0.019
L2	0.000	0.100	0.000	0.004
L3	0.000	0.100	0.000	0.004
H	0.315	0.515	0.012	0.020
θ	0°	12°	0°	12°

单击下面可查看定价，库存，交付和生命周期等信息

[>>GP\(格瑞宝\)](#)