

Introduction

The GPL1117 series is a series of low dropout three-terminal regulators with a dropout of 1.3V(typ.) at 1A output current.

The GPL1117 series provides current limiting and thermal shutdown. Its circuit includes a trimmed bandgap. Reference to assure output voltage accuracy to be within 2%. Current limit is trimmed to ensure specified. Output current and controlled short-circuit current. On-chip thermal shutdown provides protection against any combination of overload and ambient temperature that would create excessive junction temperature.

The GPL1117 series has an adjustable version, that can provide the output voltage from 1.2V to 12V with only 2 external resistors.

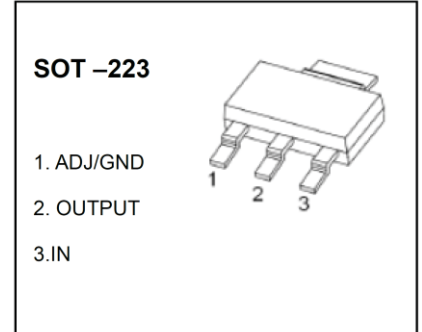

Features

- Low Dropout Voltage: 1.3V(typ.) at 1A Output Current
- Trimmed Current Limit
- On-Chip Thermal Shutdown
- Three-Terminal Adjustable or Fixed 1.2V,1.5V,1.8V, 2.5V,2.8V, 3.3V, 5V

Applications

- PC Motherboard
- LCD Monitor
- Graphic Card
- DVD-Video Player
- NIC/Switch
- Telecom Modem
- ADSL Modem
- Printer and Other Peripheral Equipment

Order Information

GPL1117①②③A④

Designator	Symbol	Description
①②③	Integer	Output Voltage e.g.1.8V=①:V, ②:1,③:8 ADJ=①②③:ADJ
④	DT	Package:SOT-223

Marking

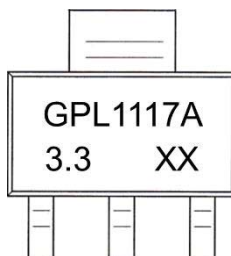

GPL1117A : Product Code
3.3 :Voltage Code
XX : Data Code

Absolute Maximum Ratings¹⁾ ($T_a=25^{\circ}\text{C}$ unless otherwise noted)

Parameter	Symbol	Ratings	Units
Input Voltage ²⁾	V_{IN}	20	V
Thermal Resistance from Junction to Ambient	$R_{\theta JA}$	100	$^{\circ}\text{C}/\text{W}$
Operating Ambient Temperature Range	T_A	-40~85	$^{\circ}\text{C}$
Operating Junction Temperature Range ³⁾	T_j	-40~150	$^{\circ}\text{C}$
Storage Temperature	T_{stg}	-40~150	$^{\circ}\text{C}$
Lead Temperature(Soldering, 10 sec)	T_{solder}	260	$^{\circ}\text{C}$
ESD rating ⁴⁾	Human Body Model -(HBM)	2.5	kV

Note: Stresses greater than those listed under "Absolute Maximum Ratings" may cause permanent damage to the device. These are stress ratings only, and functional of the device at these or any other conditions beyond those indicated under "Recommended Operating Conditions" is not implied. Exposure to "Absolute Maximum Ratings" for extended periods may affect device reliability.

Recommended Operating Conditions

Parameter	Min.	Nom.	Max.	Units
Supply voltage at V_{IN}			15	V
Operating junction temperature range, T_j	-25		125	$^{\circ}\text{C}$

Electrical Characteristics
GPL1117A Series ($V_{IN} \leq 10V$, $T_A = 25^\circ C$, unless otherwise specified)

Parameter	Symbol	Conditions	Min.	Typ.	Max.	Units
Reference Voltage	V_{IROC}	$I_{OUT} = 10mA$, $V_{IN} = 3.23V(ADJ)$	1.225	1.25	1.275	V
		$10mA \leq I_{OUT} \leq 1A$, $2.75V \leq V_{IN} - V_{OUT} \leq 12V(ADJ)$	1.219	1.25	1.281	V
Output Voltage Range	V_{OUT}	$I_{OUT} = 10mA$, $V_{IN} = 3.2V(1.2)$	1.176	1.2	1.224	V
		$10mA \leq I_{OUT} \leq 1A$, $2.7V \leq V_{IN} \leq 12V(1.2V)$	1.170	1.2	1.230	
		$I_{OUT} = 10mA$, $V_{IN} = 3.5V(1.5)$	1.470	1.5	1.530	
		$10mA \leq I_{OUT} \leq 1A$, $3.0V \leq V_{IN} \leq 12V(1.5V)$	1.463	1.5	1.537	
		$I_{OUT} = 10mA$, $V_{IN} = 3.8V(1.8)$	1.764	1.8	1.836	
		$10mA \leq I_{OUT} \leq 1A$, $3.3V \leq V_{IN} \leq 12V(1.8V)$	1.755	1.8	1.845	
		$I_{OUT} = 10mA$, $V_{IN} = 4.5V(2.5V)$	2.450	2.5	2.550	
		$10mA \leq I_{OUT} \leq 1A$, $4V \leq V_{IN} \leq 12V(2.5V)$	2.438	2.5	2.562	
		$I_{OUT} = 10mA$, $V_{IN} = 5.3V(3.3V)$	3.234	3.3	3.366	
		$10mA \leq I_{OUT} \leq 1A$, $4.8V \leq V_{IN} \leq 12V(3.3V)$	3.218	3.3	3.382	
		$I_{OUT} = 10mA$, $V_{IN} = 7.0V(5.0V)$	4.900	5.0	5.100	
		$10mA \leq I_{OUT} \leq 1A$, $6.5V \leq V_{IN} \leq 12V(5.0V)$	4.875	5.0	5.125	
Line Regulation	LNR	$I_{OUT} = 10mA$, $1.5V \leq V_{IN} - V_{OUT} \leq 10.75V(ADJ)$		0.03	0.2	%V
		$I_{OUT} = 10mA$, $1.5V \leq V_{IN} - V_{OUT} \leq 8.8V(1.2V)$		0.03	0.2	
		$I_{OUT} = 10mA$, $1.5V \leq V_{IN} - V_{OUT} \leq 8.5V(1.5V)$		0.03	0.2	
		$I_{OUT} = 10mA$, $1.5V \leq V_{IN} - V_{OUT} \leq 10.2V(1.8V)$		0.03	0.2	
		$I_{OUT} = 10mA$, $1.5V \leq V_{IN} - V_{OUT} \leq 9.5V(2.5V)$		0.03	0.2	
		$I_{OUT} = 10mA$, $1.5V \leq V_{IN} - V_{OUT} \leq 8.7V(3.3V)$		0.03	0.2	
		$I_{OUT} = 10mA$, $1.5V \leq V_{IN} - V_{OUT} \leq 7V(5.0V)$		0.03	0.2	
Load Regulation	LDR	$V_{IN} - V_{OUT} = 1.5V$, $10mA \leq I_{OUT} \leq 1A(ADJ)$		2	8	mV
		$V_{IN} - V_{OUT} = 1.5V$, $10mA \leq I_{OUT} \leq 1A(1.2V)$		2	8	
		$V_{IN} - V_{OUT} = 1.5V$, $10mA \leq I_{OUT} \leq 1A(1.5V)$		2	8	
		$V_{IN} - V_{OUT} = 1.5V$, $10mA \leq I_{OUT} \leq 1A(1.8V)$		3	12	
		$V_{IN} - V_{OUT} = 1.5V$, $10mA \leq I_{OUT} \leq 1A(2.5V)$		4	16	
		$V_{IN} - V_{OUT} = 1.5V$, $10mA \leq I_{OUT} \leq 1A(3.3V)$		6	24	
		$V_{IN} - V_{OUT} = 1.5V$, $10mA \leq I_{OUT} \leq 1A(5.0V)$		9	36	
Adjust Pin Current		$V_{IN} = 5V, I_{OUT} = 1A$		55	120	μA
Dropout Voltage	$V_{dif}^{(6)}$	$\Delta V_{REF} = 1\%$, $I_{OUT} = 1.0A$		1.3	1.5	V
I_{adj} change	I_{change}	$V_{IN} = 5V, 10mA \leq I_{OUT} \leq 1A$		0.2	10	μA
Minimum Load Current	I_L	$1.5V \leq V_{IN} - V_{OUT} \leq 12V$ (ADJ only)		2	10	mA
Quiescent Current	I_q	$V_{IN} = 10V$		2	5	mA
		$V_{IN} = 10V$		2	5	mA
		$V_{IN} = 12V$		2	5	mA
		$V_{IN} = 12V$		2	5	mA
		$V_{IN} = 12V$		2	5	mA
		$V_{IN} = 12V$		2	5	mA
		$V_{IN} = 12V$		2	5	mA
Power Supply Rejection	PSRR	$f = 120Hz, C_{OUT} = 22\mu F$ Tantalum, $V_{IN} - V_{OUT} = 3V$, $I_{OUT} = 1A$		60		dB

Functional Block Diagram

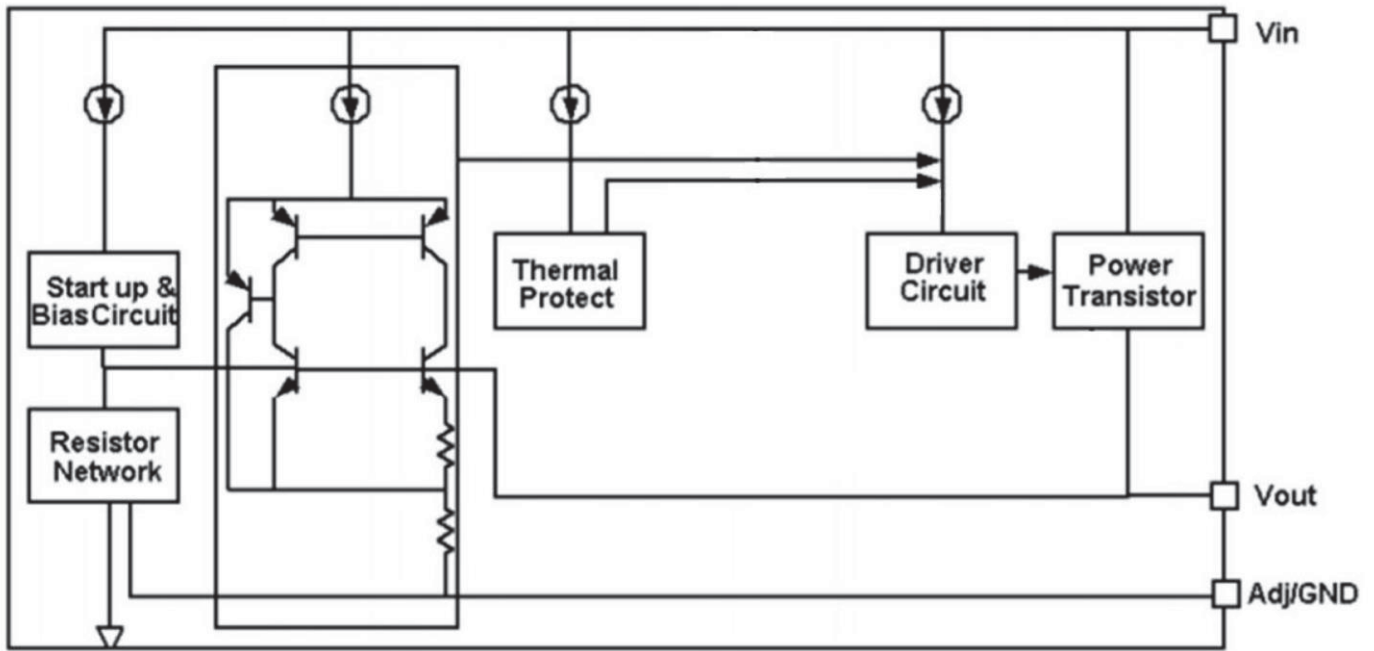

Typical Application Circuit

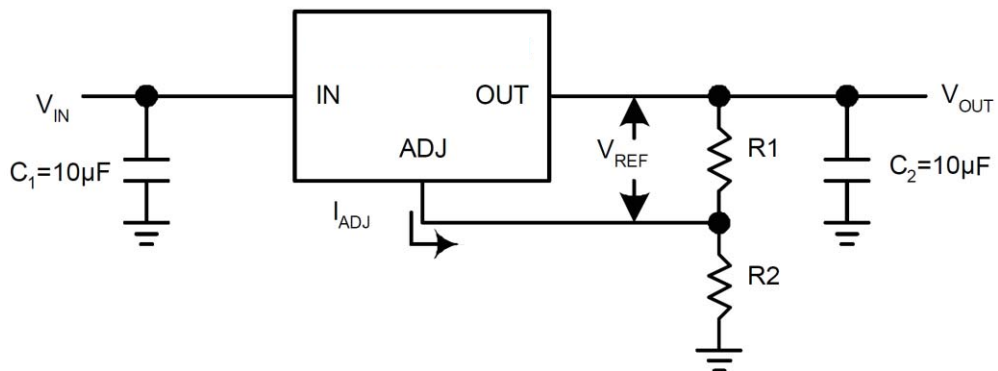
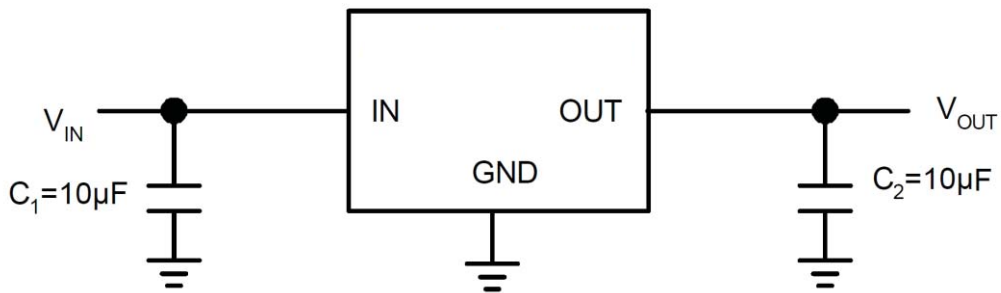

$$V_{OUT} = V_{REF} \times (1 + R2/R1) + I_{ADJ} \times R2$$

Typical Characteristics(T=25°C, unless otherwise noted.)

Line regulation

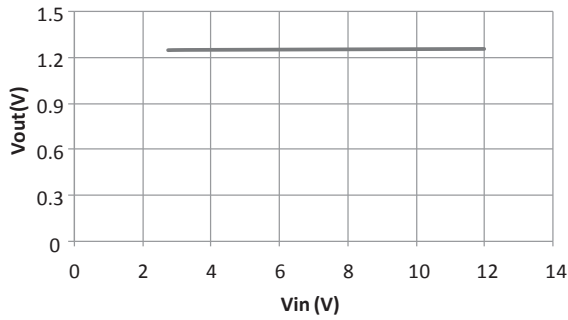

Dropout Voltage vs. Output Current

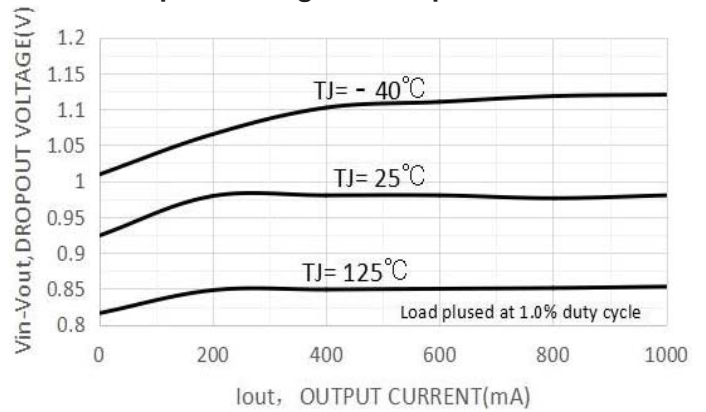

Load regulation

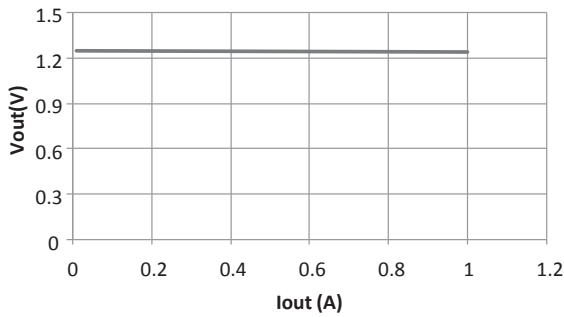

Thermal performance with OTP

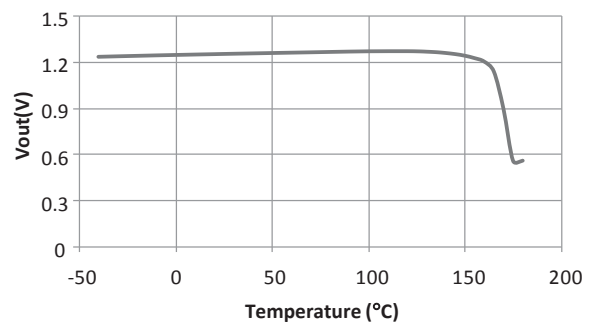

Power ON

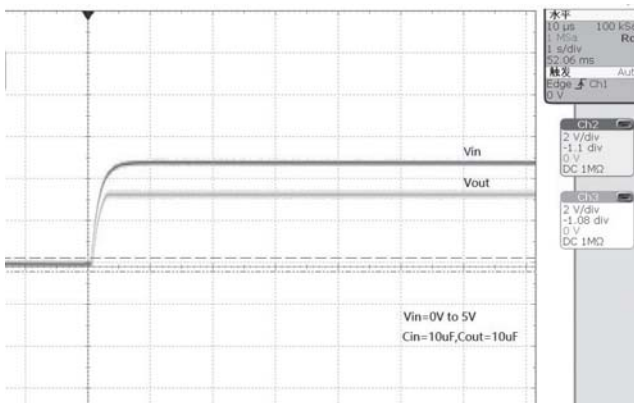

Power OFF

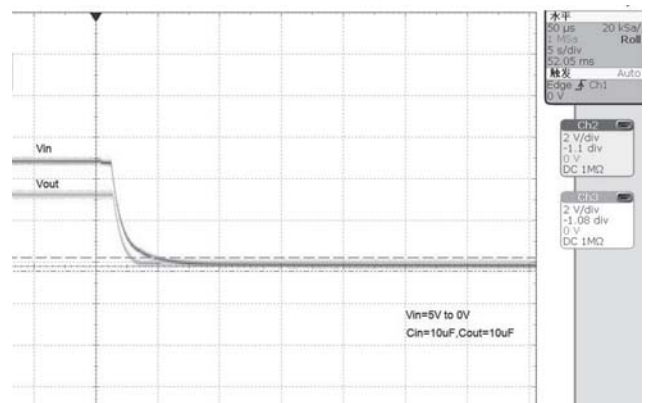

Load Transient Response

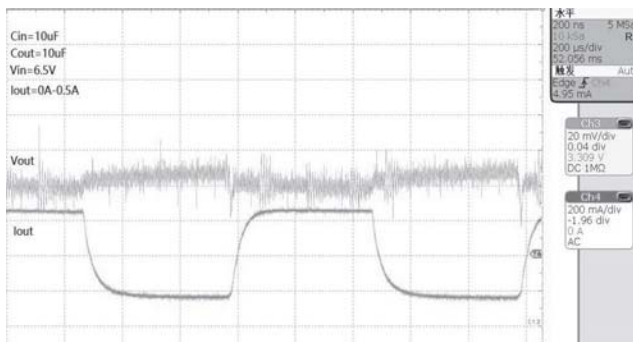

Load Transient Response

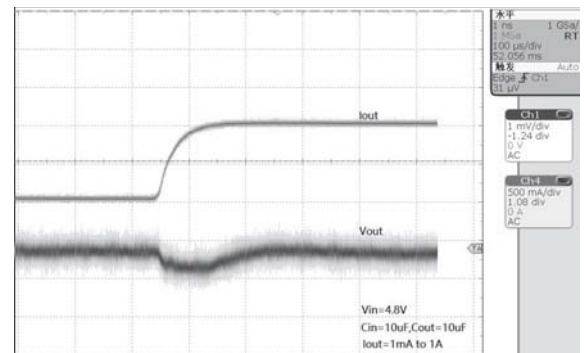

Typical Characteristics(T=25°C, unless otherwise noted.)

Load Transient Response

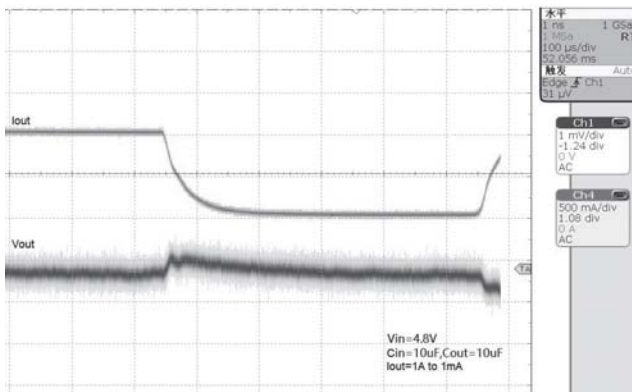

SOT-223 Package Outline Dimensions

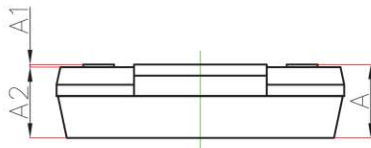
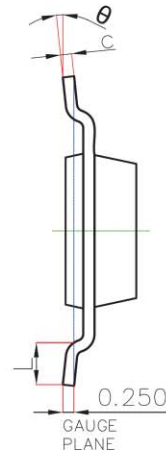
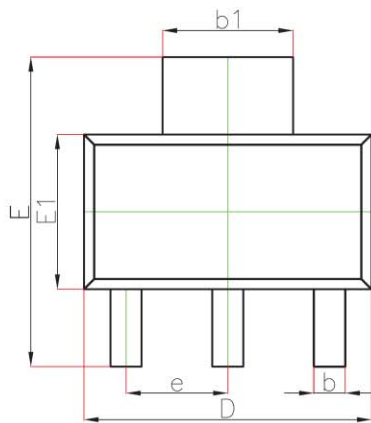

Symbol	Dimensions In Millimeters		Dimensions In Inches	
	Min.	Max.	Min.	Max.
A	—	1.800	—	0.071
A1	0.020	0.100	0.001	0.004
A2	1.500	1.700	0.059	0.067
b	0.660	0.840	0.026	0.033
b_1	2.900	3.100	0.114	0.122
c	0.230	0.350	0.009	0.014
D	6.300	6.700	0.248	0.264
E	6.700	7.300	0.264	0.287
E1	3.300	3.700	0.130	0.146
e	2.300(BSC)		0.091(BSC)	
L	0.750	—	0.030	—
θ	0°	10°	0°	10°

SOT-223 Suggested Pad Layout (Unit: mm)

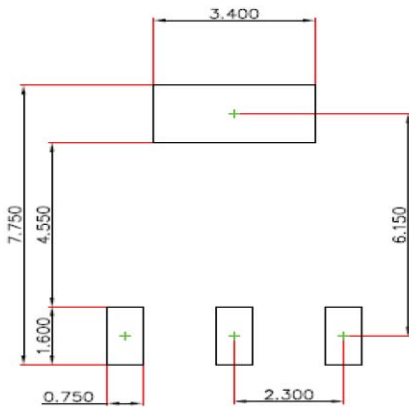

Notes:

1. General tolerance: $\pm 0.05\text{mm}$.
2. The pad layout is for reference purposes only.

单击下面可查看定价，库存，交付和生命周期等信息

[>>GP\(格瑞宝\)](#)