

Product Summary

$V_{(BR)DSS}$	$R_{DS(on)TYP}$	I_D
40V	16mΩ@10V	8A
	19mΩ@4.5V	

Feature

- Tench Power MOSFET
- Low RDS(ON)
- Low Gate Charge

Application

- Load Switch
- DC/DC Converter

MARKING:

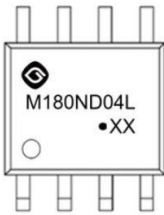

M180ND04L= Device Code
 XX = Date Code
 Solid Dot = Green Device

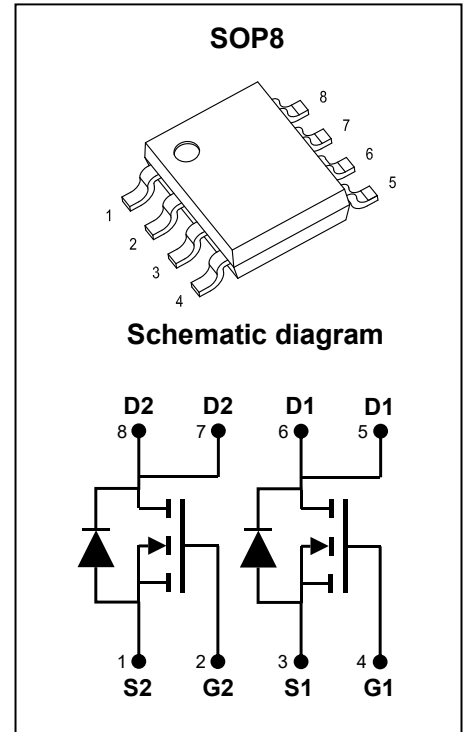

ABSOLUTE MAXIMUM RATINGS ($T_c=25^{\circ}C$ unless otherwise noted)

Parameter	Symbol	Value	Unit
Drain-Source Voltage	V_{DS}	40	V
Gate-Source Voltage	V_{GS}	±20	V
Continuous Drain Current ^{1,4}	I_D	8	A
Pulsed Drain Current ²	I_{DM}	32	A
Power Dissipation ^{4,5}	P_D	2	W
Thermal Resistance from Junction to Ambient ⁵	$R_{\theta JA}$	62.5	$^{\circ}C/W$
Junction Temperature	T_J	150	$^{\circ}C$
Storage Temperature	T_{STG}	-55~+150	$^{\circ}C$

MOSFET ELECTRICAL CHARACTERISTICS ($T_J=25^{\circ}\text{C}$ unless otherwise noted)

Parameter	Symbol	Test Condition	Min	Type	Max	Unit
Off Characteristics						
Drain-source breakdown voltage	$V_{(BR)DSS}$	$V_{GS} = 0V, I_D = 250\mu A$	40			V
Zero gate voltage drain current	I_{DSS}	$V_{DS} = 40V, V_{GS} = 0V$			1	μA
Gate-body leakage current	I_{GSS}	$V_{GS} = \pm 20V, V_{DS} = 0V$			± 100	nA
On Characteristics³						
Gate threshold voltage	$V_{GS(th)}$	$V_{DS} = V_{GS}, I_D = 250\mu A$	1.0	1.7	3.0	V
Drain-source on-resistance	$R_{DS(on)}$	$V_{GS} = 10V, I_D = 10A$		16	24	m Ω
		$V_{GS} = 4.5V, I_D = 10A$		19	35	
Dynamic Characteristics						
Input capacitance	C_{iss}	$V_{DS} = 20V, V_{GS} = 0V, f = 1\text{MHz}$		1443		pF
Output capacitance	C_{oss}			94		
Reverse transfer capacitance	C_{rss}			74		
Gate Resistance	R_g	$V_{DS} = 0V, V_{GS} = 0V, f = 1\text{MHz}$		2.1		
Switching Characteristics						
Total gate charge	Q_g	$V_{DS} = 20V, V_{GS} = 10V, I_D = 10A$		25.9		nC
Gate-source charge	Q_{gs}			4.4		
Gate-drain charge	Q_{gd}			4.8		
Turn-on delay time	$t_{d(on)}$	$V_{DD} = 20V, V_{GS} = 10V, R_G = 3\Omega, R_L = 2.5\Omega$		4		ns
Turn-on rise time	t_r			3		
Turn-off delay time	$t_{d(off)}$			14		
Turn-off fall time	t_f			2		
Source-Drain Diode Characteristics						
Diode Forward Voltage ³	V_{SD}	$V_{GS} = 0V, I_S = 20A$			1.2	V

Notes :

- 1.The maximum current rating is limited by package.
- 2.Pulse Test : Pulse Width $\leq 10\mu s$, duty cycle $\leq 1\%$.
- 3.Pulse Test : Pulse Width $\leq 300\mu s$, duty cycle $\leq 2\%$.
- 4.The power dissipation P_D is limited by $T_{J(MAX)} = 150^{\circ}\text{C}$.
- 5.Device mounted on 1in^2 FR-4 board with 2oz. Copper, in a still air environment with $T_A = 25^{\circ}\text{C}$.

Typical Electrical and Thermal Characteristics

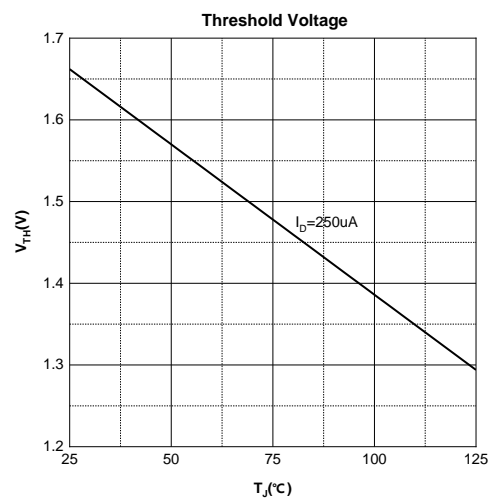
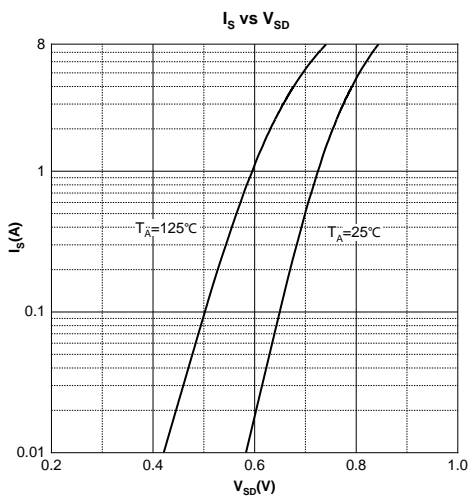
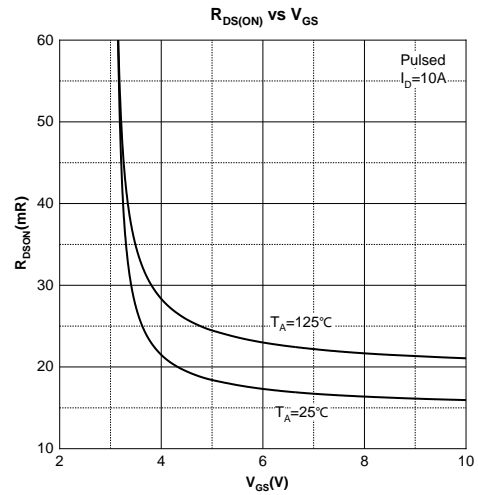
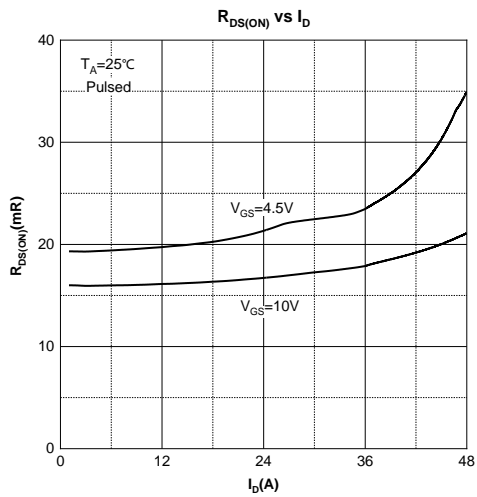
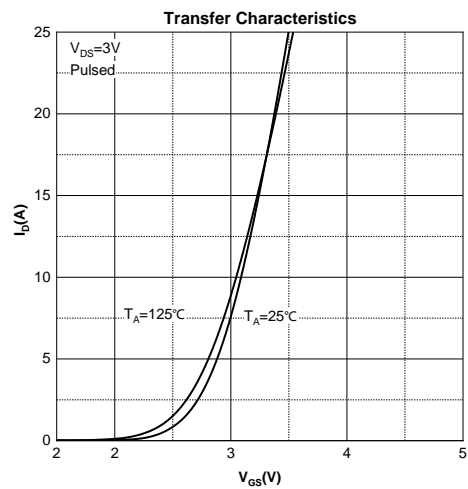
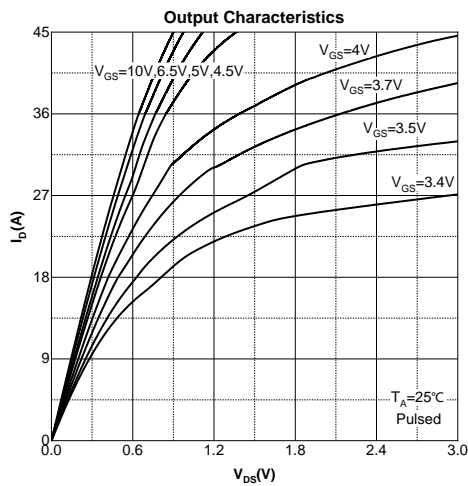

SOP8 Package Information

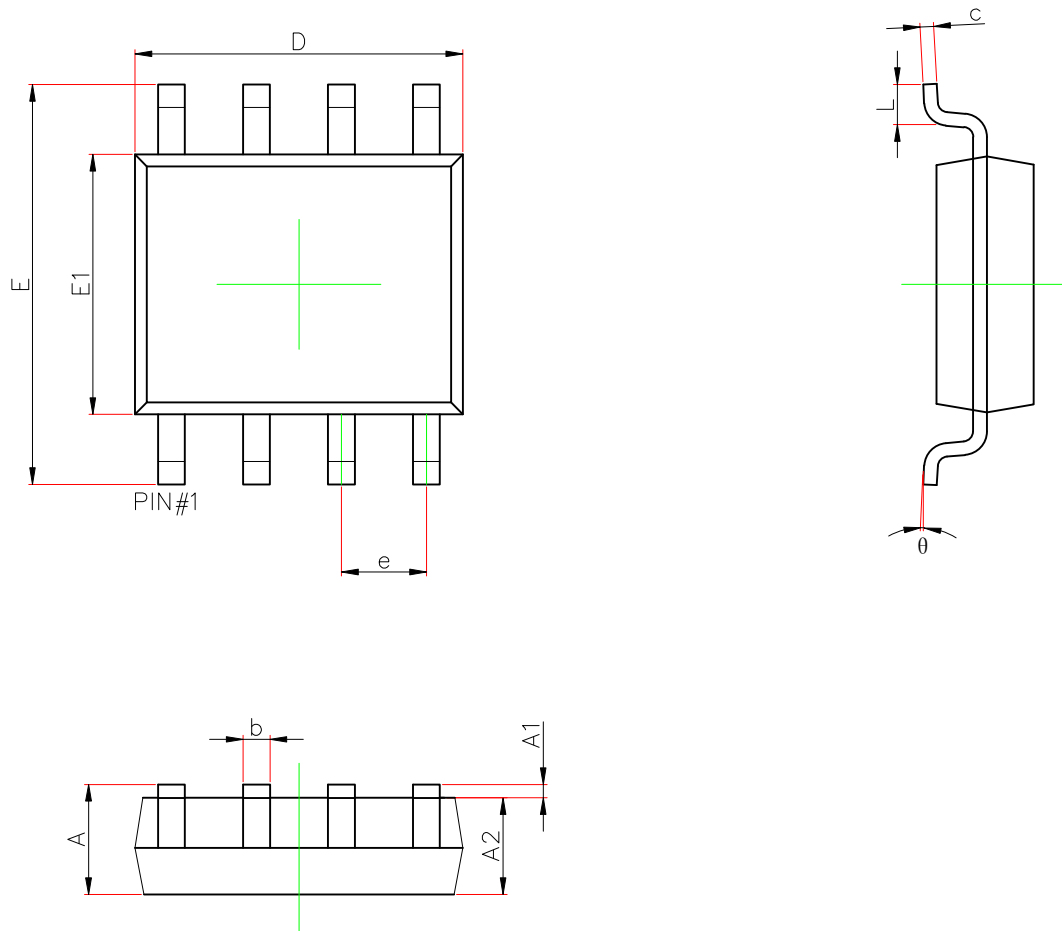

Symbol	Dimensions In Millimeters		Dimensions In Inches	
	Min.	Max.	Min.	Max.
A	1.350	1.750	0.053	0.069
A1	0.100	0.250	0.004	0.010
A2	1.350	1.550	0.053	0.061
b	0.330	0.510	0.013	0.020
c	0.156	0.250	0.006	0.010
D	4.700	5.100	0.185	0.201
e	1.270(BSC)		0.050(BSC)	
E	5.800	6.200	0.228	0.244
E1	3.700	4.100	0.146	0.161
L	0.400	1.270	0.016	0.05
θ	0°	8°	0°	8°

单击下面可查看定价，库存，交付和生命周期等信息

[>>GP\(格瑞宝\)](#)