



Product Summary

$V_{(BR)DSS}$	$R_{DS(on)TYP}$	I_D
30V	1.7m Ω @10V	150A
	2.1m Ω @4.5V	

Feature

- Trench Technology Power MOSFET
- Low $R_{DS(ON)}$
- Low Gate Charge
- Low Gate Resistance
- 100% UIS Tested

Application

- Power Switching Application

MARKING:



M017N03L = Device Code
 XX = Date Code
 Solid Dot = Green Indicator

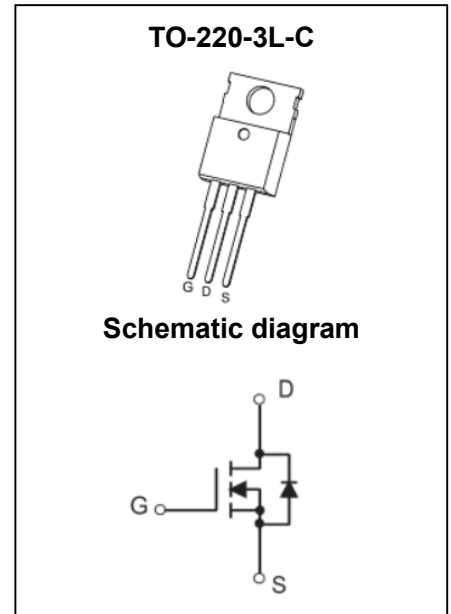

ABSOLUTE MAXIMUM RATINGS ($T_A = 25^\circ\text{C}$ unless otherwise noted)

Parameter	Symbol	Value	Unit
Drain - Source Voltage	V_{DS}	30	V
Gate - Source Voltage	V_{GS}	± 20	V
Continuous Drain Current ¹	I_D	150	A
Pulsed Drain Current ²	I_{DM}	600	A
Single Pulsed Avalanche Current ³	I_{AS}	51	A
Single Pulsed Avalanche Energy ³	E_{AS}	1300	mJ
Power Dissipation ⁵	P_D	34.7	W
Power Dissipation ⁶	P_D	2.1	W
Thermal Resistance from Junction to Ambient ⁶	$R_{\theta JA}$	60	$^\circ\text{C/W}$
Thermal Resistance from Junction to Case	$R_{\theta JC}$	3.6	$^\circ\text{C/W}$
Junction Temperature	T_J	150	$^\circ\text{C}$
Storage Temperature	T_{STG}	-55~ +150	$^\circ\text{C}$

MOSFET ELECTRICAL CHARACTERISTICS ($T_J = 25^\circ\text{C}$ unless otherwise noted)

Parameter	Symbol	Test Condition	Min	Type	Max	Unit
Off Characteristics						
Drain - Source Breakdown Voltage	$V_{(BR)DSS}$	$V_{GS} = 0V, I_D = 250\mu A$	30			V
Zero Gate Voltage Drain Current	I_{DSS}	$V_{DS} = 30V, V_{GS} = 0V$			1	μA
Gate - Body Leakage Current	I_{GSS}	$V_{GS} = \pm 20V, V_{DS} = 0V$			± 100	nA
On Characteristics⁴						
Gate Threshold Voltage	$V_{GS(th)}$	$V_{DS} = V_{GS}, I_D = 250\mu A$	1.0	1.5	3.0	V
Drain-source On-resistance	$R_{DS(on)}$	$V_{GS} = 10V, I_D = 20A$		1.7	2.8	m Ω
		$V_{GS} = 4.5V, I_D = 10A$		2.1	3.5	
Forward Transconductance	g_{FS}	$V_{DS} = 5V, I_D = 20A$		100		S
Dynamic Characteristics						
Input Capacitance	C_{iss}	$V_{DS} = 15V, V_{GS} = 0V, f = 1MHz$		7741		pF
Output Capacitance	C_{oss}			972		
Reverse Transfer Capacitance	C_{rss}			849		
Gate Resistance	R_g	$V_{DS} = 0V, V_{GS} = 0V, f = 1MHz$		1.6		Ω
Switching Characteristics						
Total Gate Charge	Q_g	$V_{DS} = 15V, V_{GS} = 10V, I_D = 10A$		141.9		nC
Gate-source Charge	Q_{gs}			18.5		
Gate-drain Charge	Q_{gd}			24.6		
Turn-on Delay Time	$t_{d(on)}$	$V_{DD} = 20V, V_{GS} = 10V, R_L = 1\Omega$ $R_G = 3\Omega$		19		ns
Turn-on Rise Time	t_r			7		
Turn-off Delay Time	$t_{d(off)}$			69		
Turn-off Fall Time	t_f			10		
Source - Drain Diode Characteristics						
Diode Forward Voltage ⁴	V_{SD}	$V_{GS} = 0V, I_S = 10A$			1.2	V

Notes :

- 1.The maximum current rating is limited by package.And device mounted on a large heatsink
- 2.Pulse Test : Pulse Width $\leq 10\mu s$, duty cycle $\leq 1\%$.
- 3.EAS condition: $V_{DD} = 45V, V_{GS} = 10V, L = 1mH, R_G = 25\Omega$ Starting $T_J = 25^\circ\text{C}$.
- 4.Pulse Test : Pulse Width $\leq 300\mu s$, duty cycle $\leq 2\%$.
- 5.The power dissipation P_D is limited by $T_{J(MAX)} = 150^\circ\text{C}$.And device mounted on a large heatsink
- 6.Device mounted on $1in^2$ FR-4 board with 2oz. Copper, in a still air environment with $T_A = 25^\circ\text{C}$.

Typical Characteristics

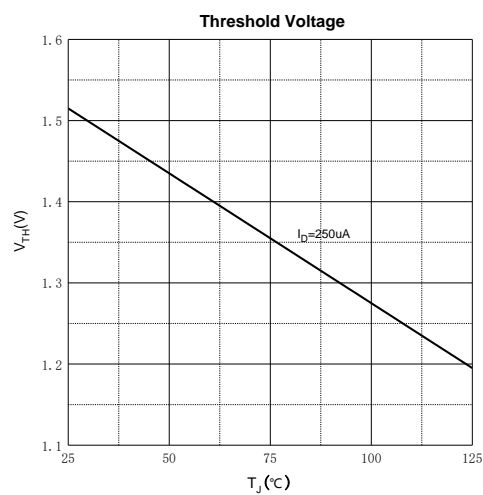
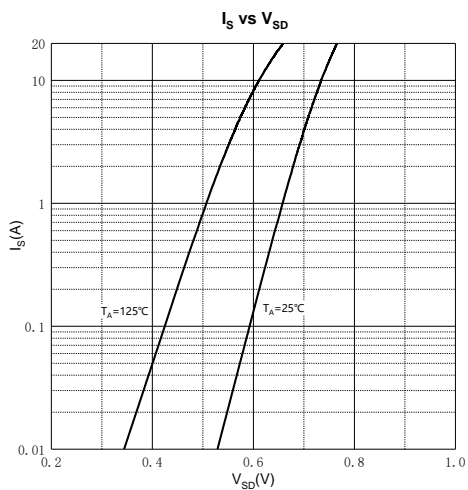
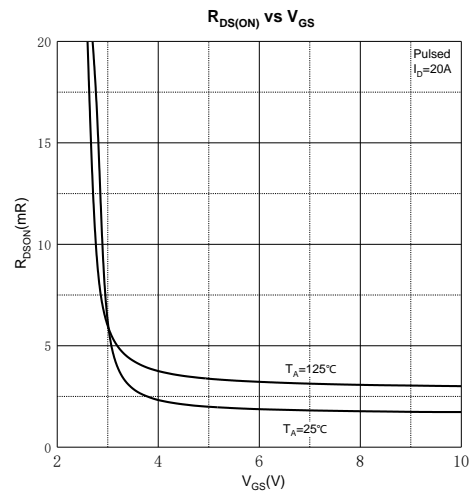
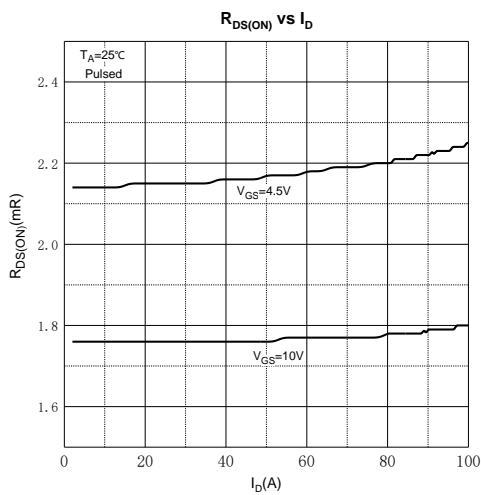
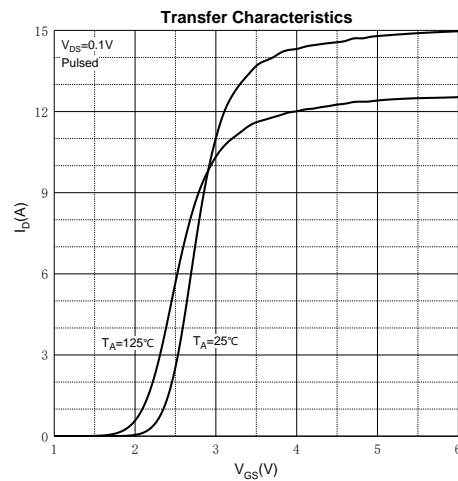
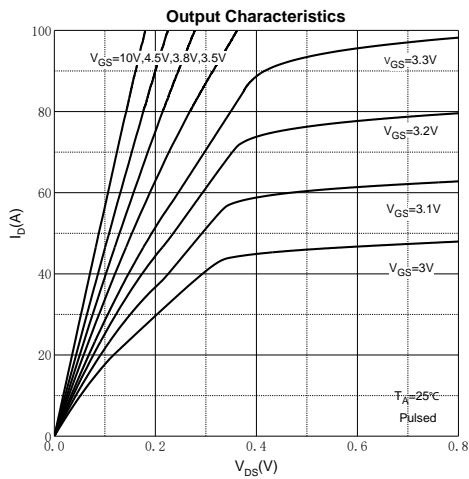

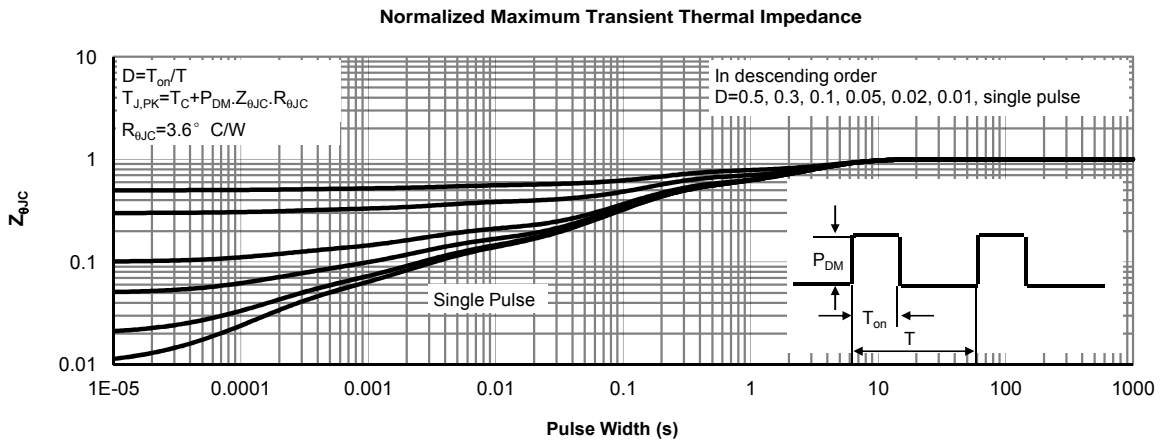
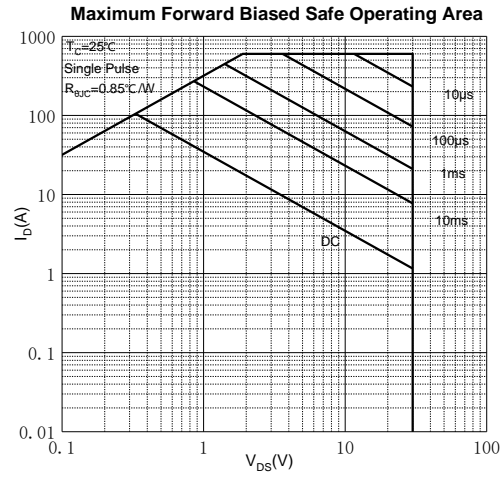
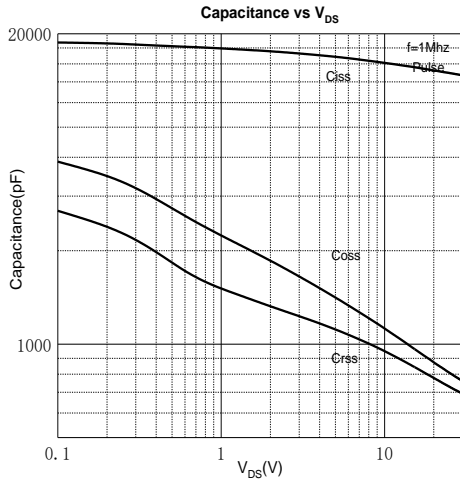

TO-220-3L-C Package Information

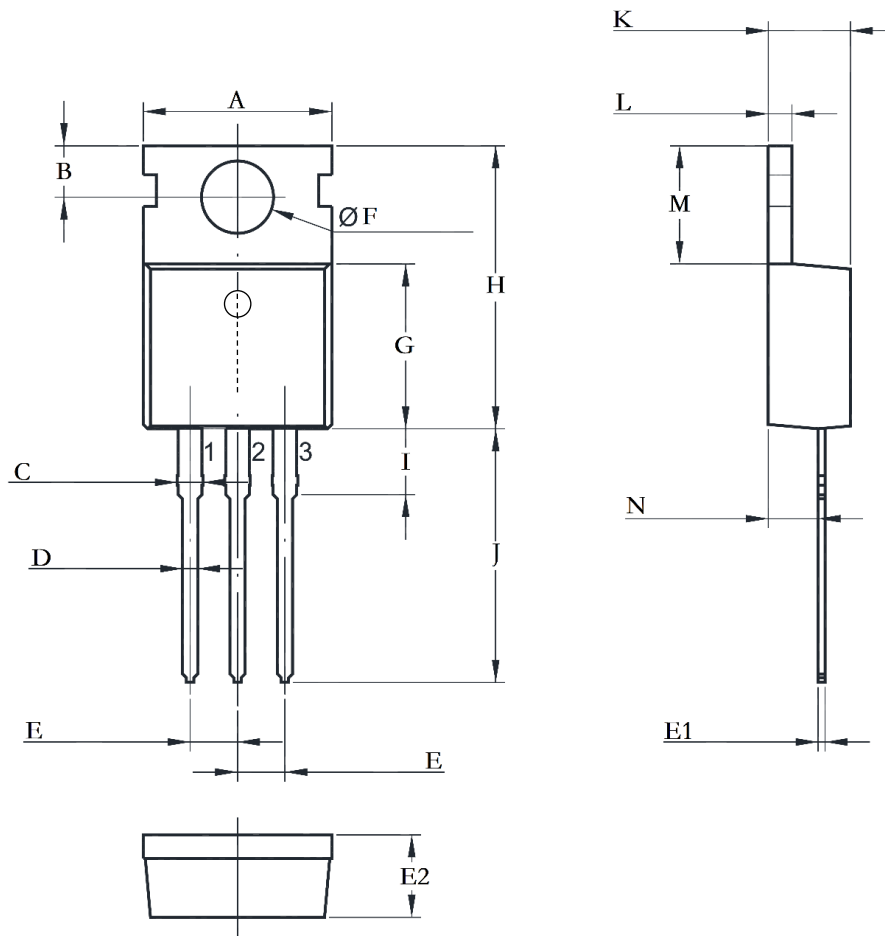

Symbol	Dimensions In Millimeters		Dimensions In Inches	
	Min.	Max.	Min.	Max.
A	9.600	10.400	0.378	0.409
B	2.800TYP		0.110TYP	
C	1.200	1.600	0.047	0.063
D	0.600	1.000	0.024	0.039
E	2.540TYP		0.100TYP	
E1	0.300	0.700	0.012	0.028
E2	4.300	4.700	0.169	0.185
F	3.400	4.000	0.134	0.157
G	8.850	9.350	0.348	0.368
H	14.600	16.100	0.575	0.634
I	2.800	4.200	0.110	0.165
J	12.600	14.800	0.496	0.583
K	4.300	4.700	0.169	0.185
L	1.000	1.400	0.039	0.055
M	5.840	7.000	0.230	0.276
N	1.800	2.900	0.071	0.114

单击下面可查看定价，库存，交付和生命周期等信息

[>>GP\(格瑞宝\)](#)