

### Product Summary

The GPL6300 series are a group of positive voltage regulators manufactured by CMOS technologies with high ripple rejection, ultra low noise, low power consumption and low dropout voltage, which can prolong battery life in portable electronics. The GPL6300 series work with low-ESR ceramic capacitors, reducing the amount of board space necessary for power applications. The GPL6300 series consume less than 0.1 $\mu$ A in shutdown mode and have fast turn-on time less than 50 $\mu$ S. The series are very suitable for the battery-powered equipments, such as RF applications and other systems requiring a quiet voltage source.

### Features

- 500mA RF Low-Dropout Regulator With Enable
- Ultralow-Noise: 40 $\mu$ VRMS(10Hz~100kHz)
- High PSRR: 70dB@1kHz
- Fast Start-Up Time (20 $\mu$ s)
- Excellent Load/Line Transient Response
- Low Dropout Voltage: 110mV@100mA
- Stable With a 1 $\mu$ F Ceramic Capacitor
- Available in Adjustable Voltage Version (0.6V to 5.5V)
- Built-in Current Limiter, Short-Circuit Protection

### Applications

- RF: VCOs, Receivers, ADCs
- Cellular and Cordless Telephones
- Handheld Organizers
- Audio
- Bluetooth, Wireless LAN
- Tablet, MID

### BLOCK DIAGRAM

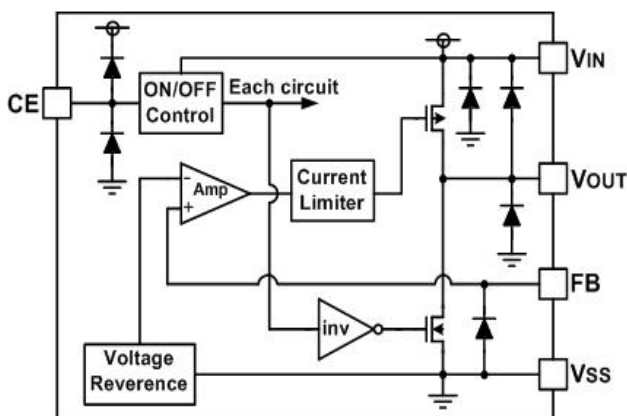

### ORDER INFORMATION

#### GPL6300①②

DESIGNATOR	SYMBOL	DESCRIPTION
①	ADJ	Adjustable Voltage Version
②	K5	Package:SOT23-5
	FP22	Package:WBHFBP-06L

## PIN CONFIGURATION

**SOT-23-5**

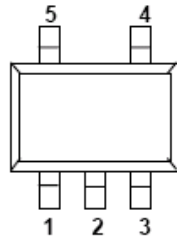

**WBHFBP-06L**

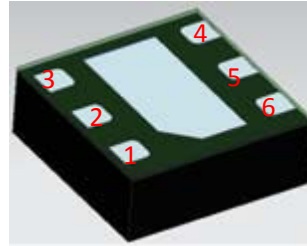

**SOT-23-5**

PIN NUMBER	SYMBOL	FUNCTION
1	$V_{IN}$	Power input Pin
2	$V_{SS}$	Ground
3	CE	Chip Enable Pin
4	FB	Feedback Pin: Used to Set Output Voltage
5	$V_{OUT}$	Output Pin

**WBHFBP-06L**

PIN NUMBER	PIN NAME	FUNCTION
1	CE	Chip Enable Pin
2	$V_{SS}$	Ground
3	$V_{IN}$	Power input Pin
4	$V_{OUT}$	Output Pin
5	NC	Not Connection
6	FB	Feedback Pin: Used to Set Output Voltage

## TYPICAL APPLICATION

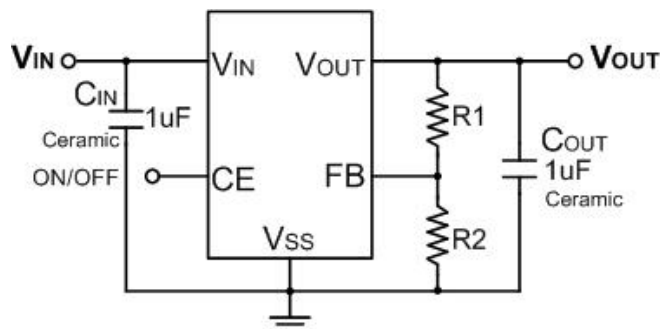

## ABSOLUTE MAXIMUM RATINGS (T<sub>a</sub>=25°C, unless otherwise noted)

PARAMETER		SYMBOL	RATINGS	UNITS
Input Voltage		V <sub>IN</sub>	V <sub>SS</sub> -0.3~V <sub>SS</sub> +8	V
Output Current		I <sub>OUT</sub>	750	mA
Output Voltage		V <sub>OUT</sub>	V <sub>SS</sub> -0.3~V <sub>IN</sub> +0.3	V
Power Dissipation	SOT-23-5	P <sub>d</sub>	400	mW
	SOT-23-6	P <sub>d</sub>	400	mW
Operating Temperature		T <sub>opr</sub>	-40~+85	°C
Storage Temperature		T <sub>stg</sub>	-40~+125	°C
Soldering Temperature & Time		T <sub>solder</sub>	260°C, 10s	

## ELECTRICAL CHARACTERISTICS

(V<sub>IN</sub>=V<sub>OUT</sub>+1V, C<sub>IN</sub>=C<sub>OUT</sub>=1μF, T<sub>A</sub>=25°C, unless otherwise specified)

PARAMETER	SYMBOL	CONDITIONS	MIN.	TYP.	MAX.	UNITS
Input Voltage	V <sub>IN</sub>	—	1.8 <sup>(1)</sup>		7.0	V
Output Current	I <sub>OUT</sub>	V <sub>OUT</sub> ≥ 1.8V	500			mA
Supply Current	I <sub>SS</sub>	I <sub>OUT</sub> =0mA		45	80	μA
Standby Current	I <sub>STBY</sub>	V <sub>CE</sub> =0V			0.1	μA
CE "High" Voltage	V <sub>CEH</sub>		1.2		V <sub>IN</sub>	V
CE "Low" Voltage	V <sub>CEL</sub>				0.3	V
CE pin current		V <sub>CE</sub> =0V	-1		1	V
FB Voltage	V <sub>FB</sub>	I <sub>OUT</sub> =1mA	0.588	0.600	0.612	V
FB pin current		V <sub>FB</sub> =1.8V			1	μA
Output voltage range			0.6		5.5 - V <sub>DO</sub>	V
Line Regulation	$\frac{\Delta V_{OUT}}{V_{OUT} \times \Delta V_{IN}}$	I <sub>OUT</sub> =10mA V <sub>OUT</sub> +1V ≤ V <sub>IN</sub> ≤ 7V		0.01	0.2	%/V
Load Regulation	ΔV <sub>OUT</sub>	V <sub>IN</sub> = V <sub>OUT</sub> +1V, 1mA ≤ I <sub>OUT</sub> ≤ 100mA		1		mV
Dropout Voltage <sup>(2)</sup>	V <sub>dif</sub>	I <sub>OUT</sub> =100mA V <sub>OUT</sub> ≥ 3.0V		110		mV
Output Voltage Temperature Characteristics	$\frac{\Delta V_{OUT}}{\Delta T \times V_{OUT}}$	I <sub>OUT</sub> =10mA -40 ≤ T ≤ +85		50		ppm
Current Limit	I <sub>LIM</sub>		600	750		mA
Short Current	I <sub>SHORT</sub>	V <sub>OUT</sub> = V <sub>SS</sub>		20		mA
Power Supply Ripple Rejection	V <sub>OUT</sub> =1.2V	PSRR	f=100Hz, I <sub>OUT</sub> =50mA		80	dB
			f=1kHz, I <sub>OUT</sub> =50mA		70	
			f=10kHz, I <sub>OUT</sub> =50mA		50	
Output noise voltage		BW=10Hz to 100kHz, I <sub>OUT</sub> =10mA		40		μV <sub>RMS</sub>
Time, start-up		I <sub>OUT</sub> =0mA, C <sub>OUT</sub> =1μF		20		μS

### NOTE:

(1) Minimum V<sub>IN</sub> is 1.8V or V<sub>OUT</sub> + V<sub>DO</sub>, whichever is greater.

(2) V<sub>dif</sub>: The difference of output voltage and input voltage when input voltage is decreased gradually till output voltage equals to 98% of V<sub>OUT</sub> (E). Voltage Equals To 98% Of V<sub>OUT</sub> (E).

## DROPOUT VOLTAGE CHART ELECTRICAL CHARACTERISTICS

Setting Output Voltage	Dropout Voltage (mV) Typ.			
V <sub>OUT</sub> (V)	I <sub>OUT</sub> =100mA	I <sub>OUT</sub> =200mA	I <sub>OUT</sub> =300mA	I <sub>OUT</sub> =500mA
1.2	372mV	642mV	876mV	1.368V
1.5	248mV	471mV	681mV	1.128V
1.8	189mV	370mV	550mV	947mV
2.1	157mV	311mV	469mV	820mV
2.5	132mV	265mV	400mV	706mV
2.8	120mV	241mV	365mV	645mV
3.0	111mV	229mV	348mV	612mV
3.3	107mV	214mV	325mV	574mV
3.6	101mV	203mV	307mV	542mV
4.0	98mV	184mV	292mV	506mV
4.5	93mV	183mV	275mV	474mV
5.0	88mV	173mV	261mV	446mV

### Typical Performance Characteristics

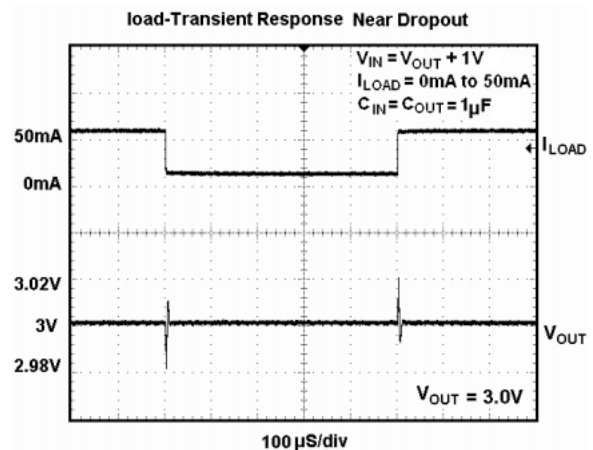
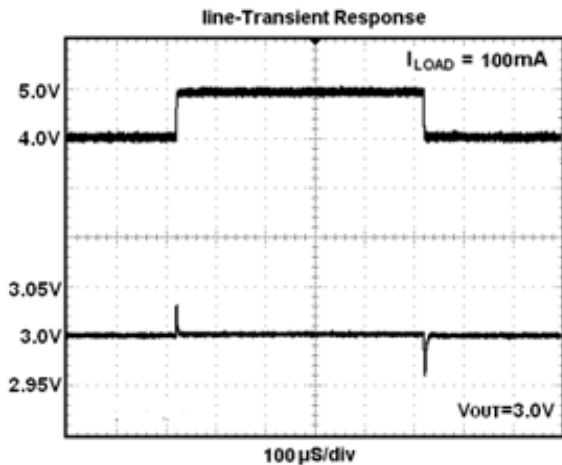
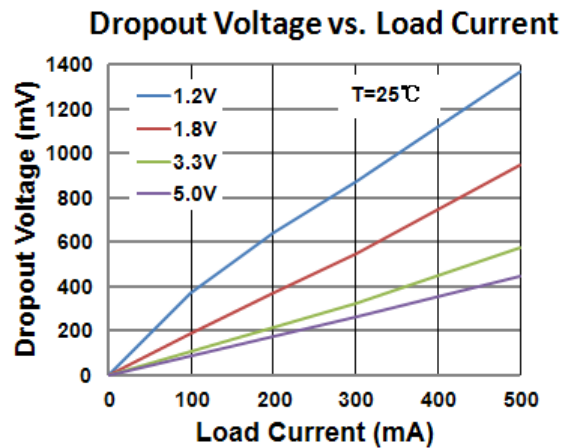
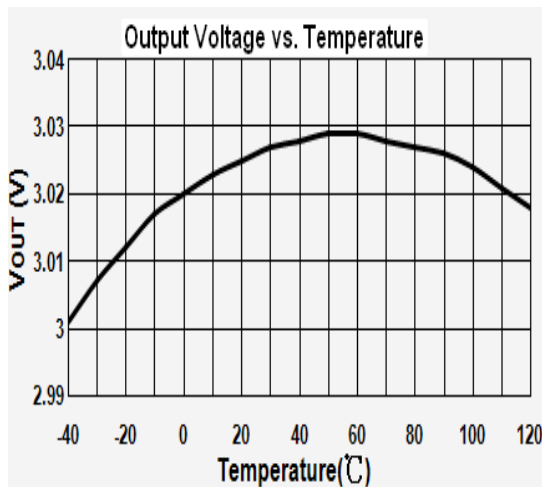

## Typical Performance Characteristics

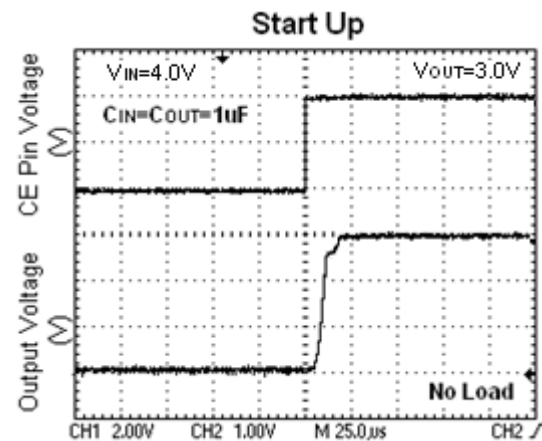
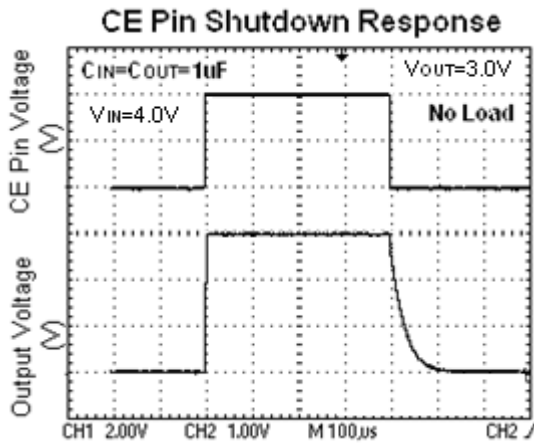
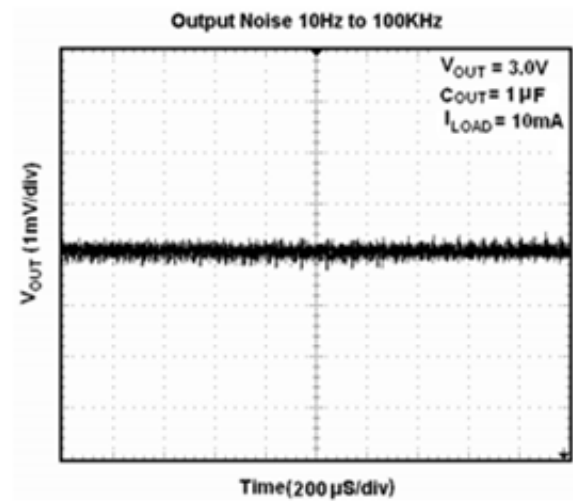
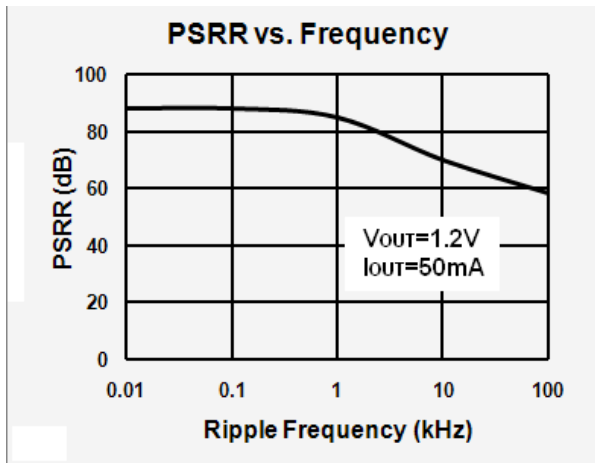

## APPLICATION INFORMATION

### Setting The Output Voltage

Figure 1 shows the typical application circuit with GPL6300. The external resistor sets the output voltage according to the following equation:

$$V_{OUT} = 0.6V \times \left(1 + \frac{R1}{R2}\right)$$

Table 1. Resistor select for output voltage setting

$V_{OUT}$	R1	R2
1.2V	30.1K	30.1K
1.5V	45.3K	30.1K
1.8V	60.4K	30.1K
2.5V	95.3K	30.1k
2.8V	110K	30.1k
3.0V	120K	30.1K
3.3V	137K	30.1K
5.0V	221K	30.1k

## WBHFBP-06L Package Information

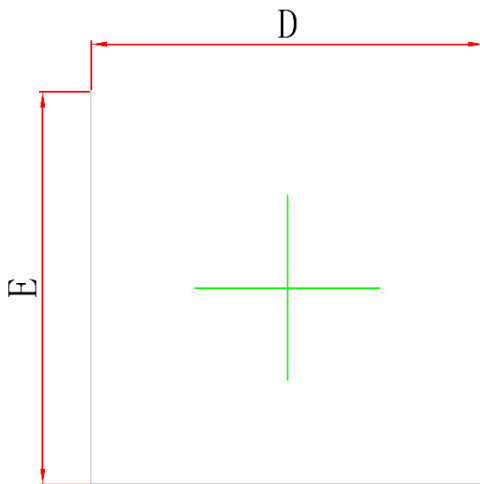

TOP VIEW  
[顶视图]

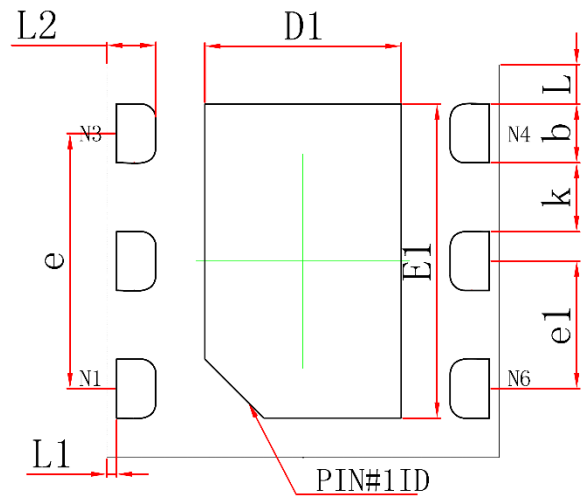

BOTTOM VIEW  
[背视图]

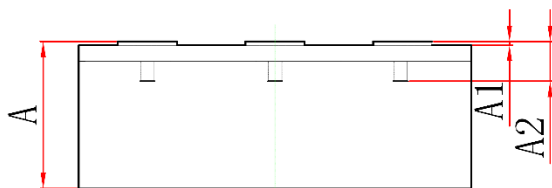

SIDE VIEW  
[侧视图]

Symbol	Dimensions In Millimeters		Dimensions In Inches	
	Min.	Max.	Min.	Max.
A	0.700	0.800	0.028	0.031
A1	0.000	0.050	0.000	0.002
A2	0.203REF.		0.008REF.	
D	1.950	2.050	0.077	0.081
E	1.950	2.050	0.077	0.081
D1	0.950	1.050	0.037	0.041
E1	1.550	1.650	0.061	0.065
b	0.250	0.350	0.010	0.014
e	1.300REF.		0.051REF.	
e1	0.650BSC.		0.026BSC.	
k	0.350REF.		0.014REF.	
L	0.200REF.		0.008REF.	
L1	0.050REF.		0.002REF.	
L2	0.200	0.300	0.008	0.012

## SOT-23-5L Package Outline Dimensions

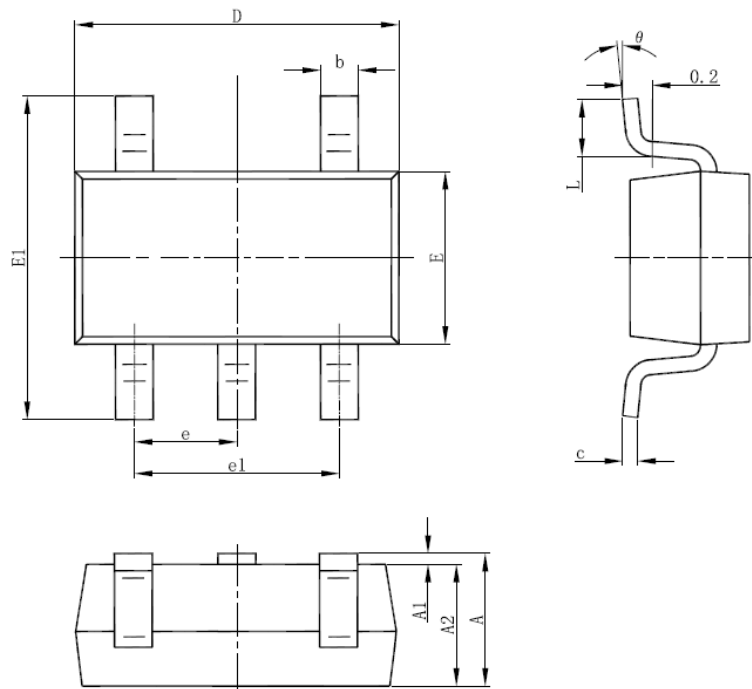

Symbol	Dimensions In Millimeters	
	Min.	Max.
A	1.05	1.25
A1	0.00	0.10
A2	1.05	1.15
b	0.30	0.50
c	0.10	0.20
D	2.82	3.02
E	1.50	1.70
E1	2.65	2.95
e	0.95 REF.	
e1	1.80	2.00
L	0.30	0.50

单击下面可查看定价，库存，交付和生命周期等信息

[>>GP\(格瑞宝\)](#)