

Product Summary

The GESDBL7V0D51 is designed to protect voltage sensitive electronic components from ESD and other transients. Excellent clamping capability, low leakage, low capacitance, and fast response time, make these parts ideal for ESD protection on designs where board space is at a premium. Because of its small size, it is suited for use in digital cameras, cellular phones, MP3 players and many other portable applications where board space is at a premium.

Feature

- Low reverse stand-off voltage: 7V Max.
- Low reverse clamping voltage
- Ultra-low leakage current
- Fast response time
- IEC 61000-4-2 Level 4 ESD protection

Application

- Computers and peripherals
- Portable electronics
- Audio and video equipment
- Cellular handsets and accessories
- Other electronics equipment communication systems

Marking:



Front Side
Z =Device Code

SOD-523

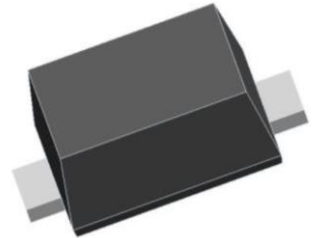

Schematic diagram

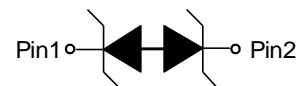

Absolute Maximum Ratings (Ta=25°C unless otherwise noted)

| Parameter | Symbol | Value | Unit |
|-----------------------------|----------------------|-----------|------|
| IEC 61000-4-2 ESD Voltage | Air Model | ±30 | kV |
| IEC 61000-4-2 ESD Voltage | Contact Model | ±30 | |
| JESD22-A114-B ESD Voltage | Per Human Body Model | ±16 | |
| ESD Voltage | Machine Model | ±0.4 | |
| Peak Pulse Power (8/20μs) | P _{pk} | 75 | W |
| Peak Pulse Current (8/20μs) | I _{PP} | 5 | A |
| Junction Temperature | T _J | -55~ +125 | °C |
| Storage Temperature | T _{stg} | -55~ +150 | °C |

ESD standards compliance

IEC61000-4-2 Standard

| Contact Discharge | | Air Discharge | |
|-------------------|-----------------|---------------|-----------------|
| Level | Test Voltage kV | Level | Test Voltage kV |
| 1 | 2 | 1 | 2 |
| 2 | 4 | 2 | 4 |
| 3 | 6 | 3 | 8 |
| 4 | 8 | 4 | 15 |

JESD22-A114-B Standard

| ESD Class | Human Body Discharge V |
|-----------|------------------------|
| 0 | 0~249 |
| 1A | 250~499 |
| 1B | 500~999 |
| 1C | 1000~1999 |
| 2 | 2000~3999 |
| 3A | 4000~7999 |
| 3B | 8000~15999 |

Contact discharge current waveform per IEC61000-4-2

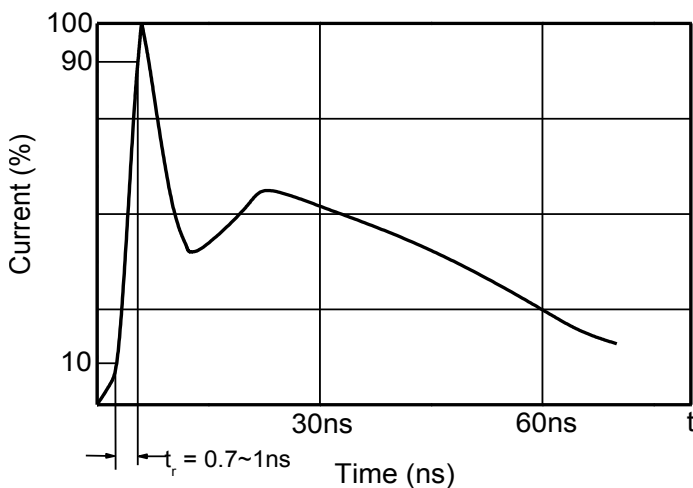

8/20μs waveform per IEC61000-4-5

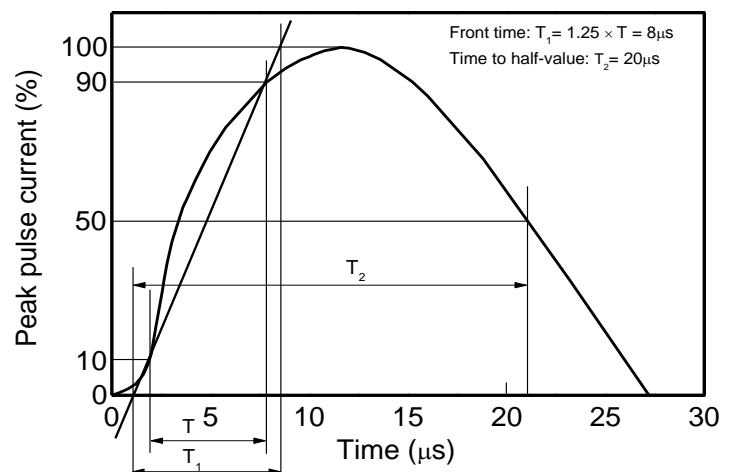

Electrical Parameter

| Symbol | Parameter |
|------------------|--|
| V _C | Clamping Voltage @ I _{PP} |
| I _{PP} | Peak Pulse Current |
| V _{BR} | Breakdown Voltage @ I _{BR} |
| I _{BR} | Test Current |
| I _R | Reverse Leakage Current @ V _{RWM} |
| V _{RWM} | Reverse Standoff Voltage |

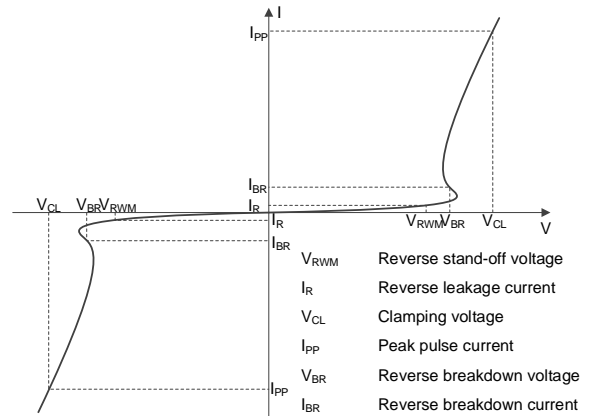

V-I characteristics for a Bi-directional TVS

Electrical Characteristics (T_a=25°C unless otherwise specified)

| Parameter | Symbol | Test conditions | Min | Typ | Max | Unit |
|---------------------------|--------------------------------|----------------------------|-----|-----|-----|------|
| Reverse stand-off voltage | V _{RWM} ¹⁾ | | | | 7 | V |
| Reverse leakage current | I _R | V _{RWM} =7V | | | 0.6 | uA |
| Breakdown voltage | V _(BR) | I _T =1mA | 7.5 | | 10 | V |
| Clamping voltage | V _C ²⁾ | I _{PP} =1A | | | 10 | V |
| | V _C ²⁾ | I _{PP} =5A | | 13 | 15 | V |
| Junction capacitance | C _J | V _R =0V, f=1MHz | | 10 | 15 | pF |

- 1) Other voltages available upon request.
- 2) Non-repetitive current pulse 8/20μs exponential decay waveform according to IEC61000-4-5

Typical Characteristics

V_C vs. I_{PP}

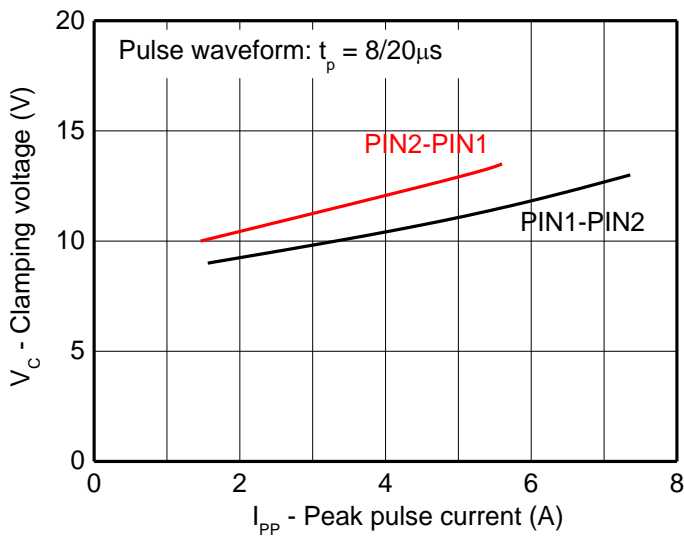

I-V Curve

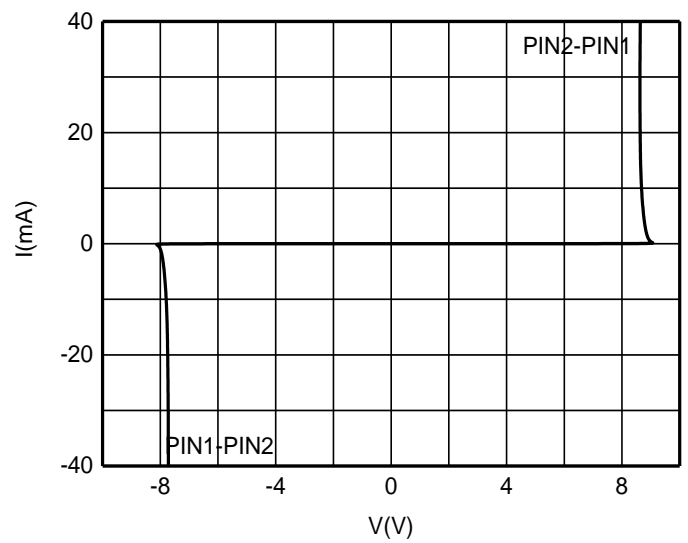

Peak pulse power vs. Pulse time

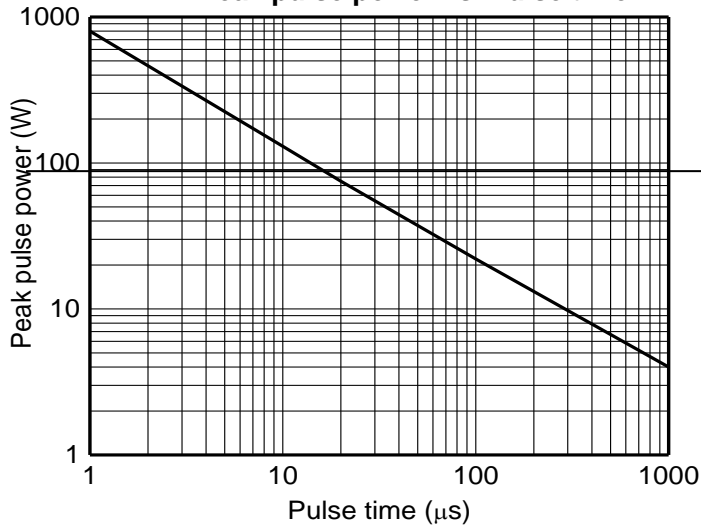

Power derating vs. Ambient temperature

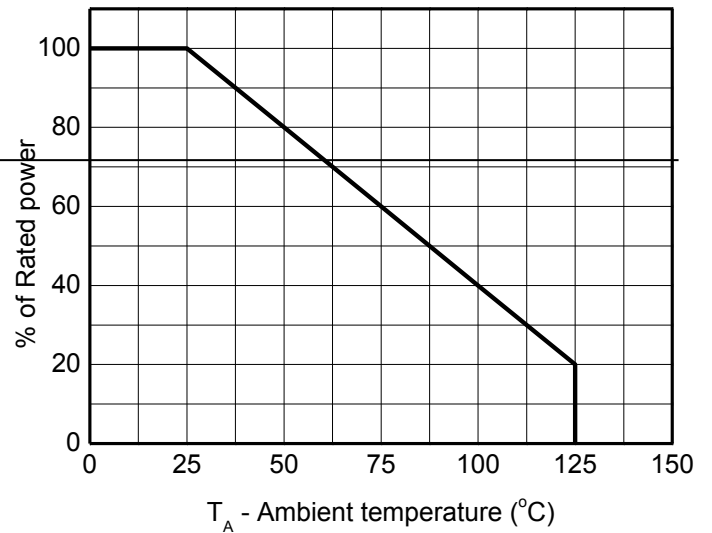

SOD-523 Package Outline Dimensions

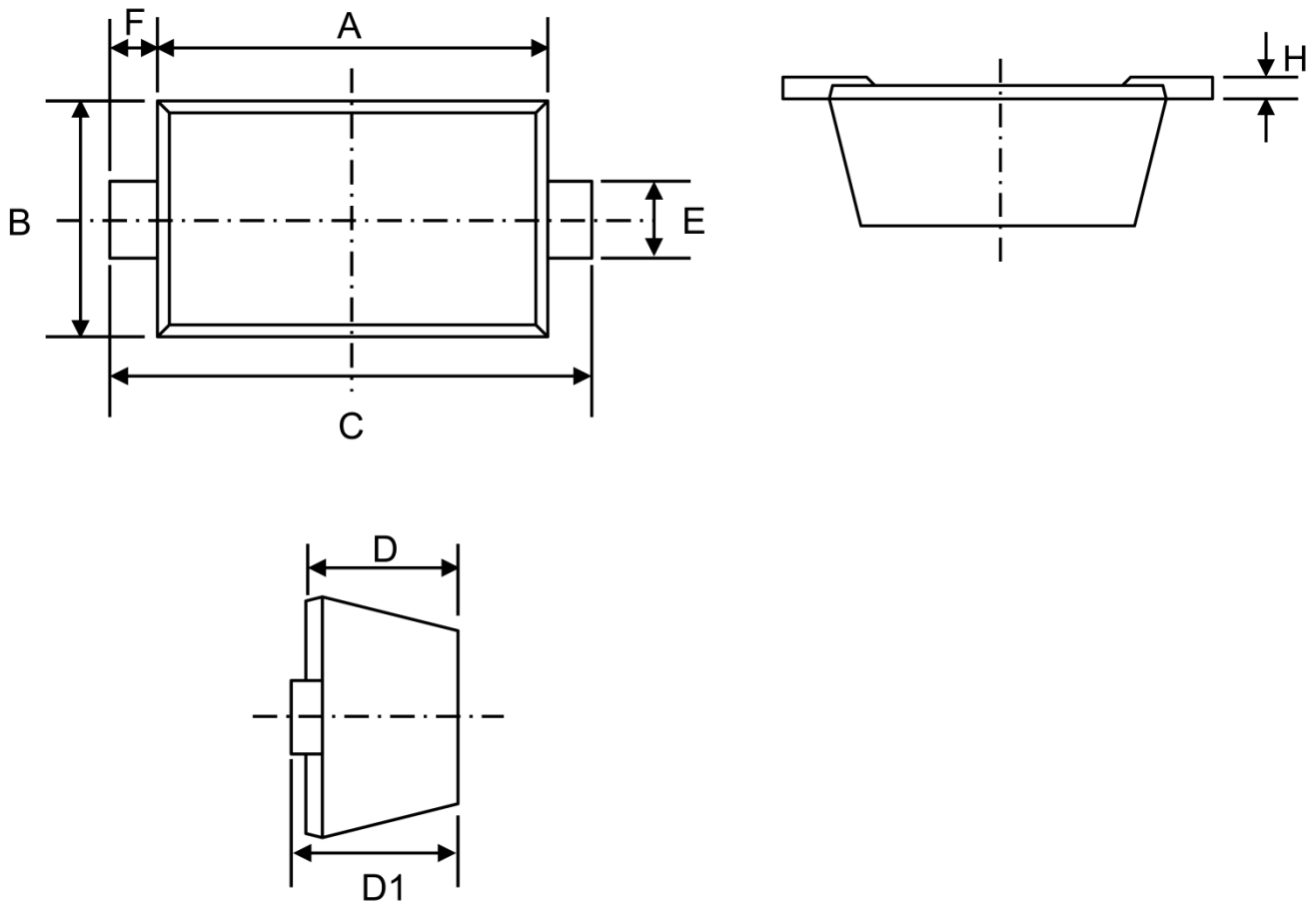

| | Dimensions In Millimeters | |
|----|---------------------------|------|
| | Min. | Max. |
| A | 1.10 | 1.30 |
| B | 0.70 | 0.90 |
| C | 1.50 | 1.70 |
| D | 0.50 | 0.70 |
| D1 | 0.51 | 0.77 |
| E | 0.25 | 0.35 |
| F | 0.20REF | |
| H | 0.07 | 0.20 |

单击下面可查看定价，库存，交付和生命周期等信息

[>>GP\(格瑞宝\)](#)