



#### Product Summary

$V_{(BR)DSS}$	$R_{DS(on)TYP}$	$I_D$
18V	9.0mΩ@4.5V	8A
	9.5mΩ@4.0V	
	10mΩ@3.8V	
	11mΩ@3.1V	
	12mΩ@2.5V	

#### DESCRIPTION

The GP1809S uses advanced trench technology to provide excellent  $R_{DS(ON)}$  and low gate charge. This device is suitable for use as a uni-directional or bi-directional load switch, facilitated by its common-drain configuration.

#### MARKING:

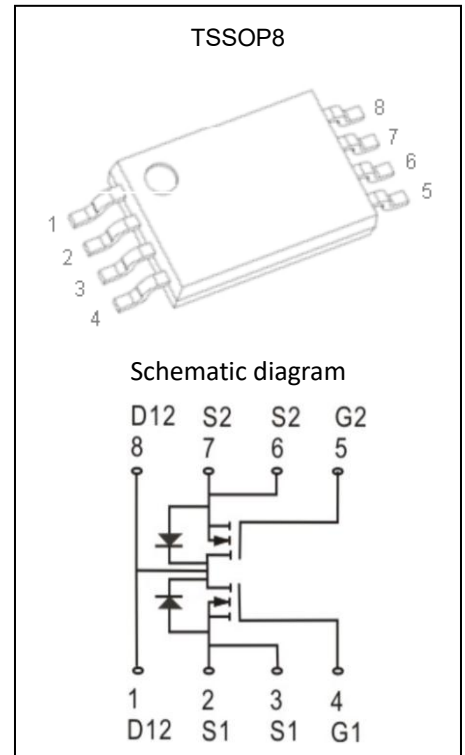
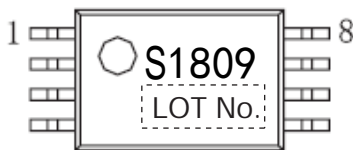

#### ABSOLUTE MAXIMUM RATINGS ( $T_a=25^\circ\text{C}$ unless otherwise noted)

Parameter	Symbol	Value	Unit
Drain-Source Voltage	$V_{DS}$	18	V
Gate-Source Voltage	$V_{GS}$	$\pm 10$	V
Continuous Drain Current	$I_D$	8	A
Pulsed Drain Current	$I_{DM}$	32	A
Power Dissipation	$P_D$	2	W
Thermal Resistance from Junction to Ambient	$R_{\theta JA}$	62.5	$^\circ\text{C/W}$
Junction Temperature	$T_J$	150	$^\circ\text{C}$
Storage Temperature	$T_{STG}$	-55~ +150	$^\circ\text{C}$
Lead Temperature for Soldering Purposes(1/8" from case for 10s)	$T_L$	260	$^\circ\text{C}$

**MOSFET ELECTRICAL CHARACTERISTICS(T<sub>a</sub>=25°C unless otherwise noted)**

Parameter	Symbol	Test Condition	Min	Type	Max	Unit
<b>Static Characteristics</b>						
Drain-source breakdown voltage	V <sub>(BR)DSS</sub>	V <sub>GS</sub> = 0V, I <sub>D</sub> =250μA	18			V
Zero gate voltage drain current	I <sub>DSS</sub>	V <sub>DS</sub> =16V, V <sub>GS</sub> = 0V			1	μA
Gate-body leakage current	I <sub>GSS</sub>	V <sub>GS</sub> =±10V, V <sub>DS</sub> = 0V			±100	nA
Gate threshold voltage <sup>(1)</sup>	V <sub>GS(th)</sub>	V <sub>DS</sub> =V <sub>GS</sub> , I <sub>D</sub> =250μA	0.4		1.0	V
Drain-source on-resistance <sup>(1)</sup>	R <sub>DS(on)</sub>	V <sub>GS</sub> =4.5V, I <sub>D</sub> =3A		9.0	12.0	mΩ
		V <sub>GS</sub> =4.0V, I <sub>D</sub> =3A		9.5	12.5	
		V <sub>GS</sub> =3.8V, I <sub>D</sub> =3A		10	13.0	
		V <sub>GS</sub> =3.1V, I <sub>D</sub> =3A		11	14.5	
		V <sub>GS</sub> =2.5V, I <sub>D</sub> =3A		12	15.0	
Forward tranconductance <sup>(1)</sup>	g <sub>FS</sub>	V <sub>DS</sub> =5V, I <sub>D</sub> =7A	6			S
Diode Forward voltage <sup>(1)</sup>	V <sub>DS</sub>	V <sub>GS</sub> =0V, I <sub>S</sub> =3A			1.2	V
<b>Dynamic characteristics<sup>(2)</sup></b>						
Input Capacitance	C <sub>iss</sub>	V <sub>DS</sub> =10V, V <sub>GS</sub> =0V, f =1MHz		680		pF
Output Capacitance	C <sub>oss</sub>			132		
Reverse Transfer Capacitance	C <sub>rss</sub>			121		
Total gate charge	Q <sub>g</sub>	V <sub>DS</sub> =10V, V <sub>GS</sub> =4.5V, I <sub>D</sub> =8A		16		nC
Gate-source charge	Q <sub>gs</sub>			1.4		
Gate-drain charge	Q <sub>gd</sub>			4.5		
<b>Switching Characteristics<sup>(2)</sup></b>						
Turn-on delay time	t <sub>d(on)</sub>	V <sub>GEN</sub> =5V, V <sub>DD</sub> =10V, I <sub>D</sub> =4A, R <sub>G</sub> =1Ω, R <sub>L</sub> =2.2Ω			10	ns
Turn-on rise time	t <sub>r</sub>				20	
Turn-off delay time	t <sub>d(off)</sub>				32	
Turn-off fall time	t <sub>f</sub>				12	
<b>Drain-Source Diode Charac teristics</b>						
Diode Forward Current	I <sub>S</sub>				8.0	A

**Notes :**

1. Pulse Test : Pulse width≤300μs, duty cycle≤0.5%.
2. Guaranteed by design, not subject to production testing.

**Typical Electrical and Thermal Characteristics**

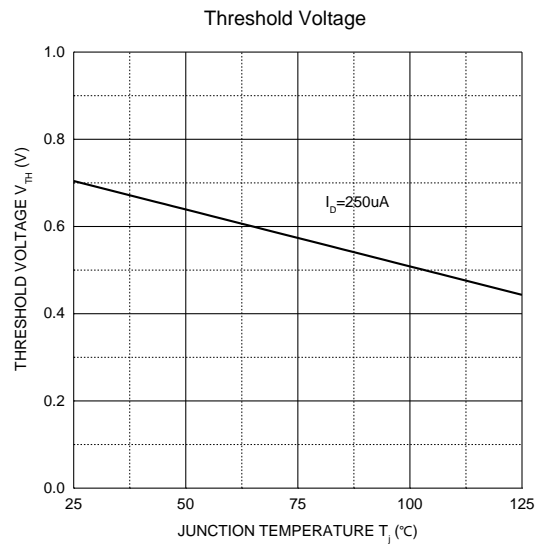
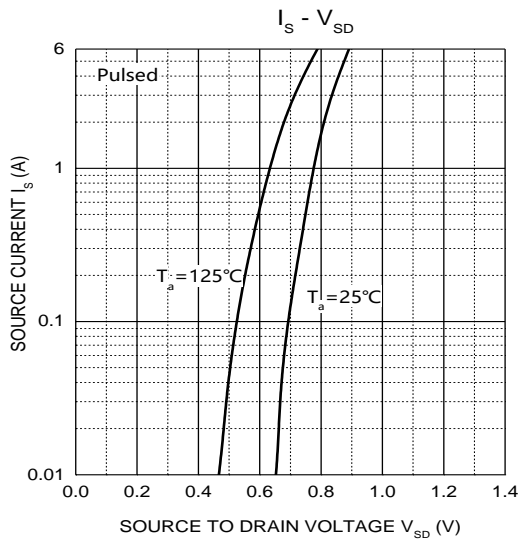
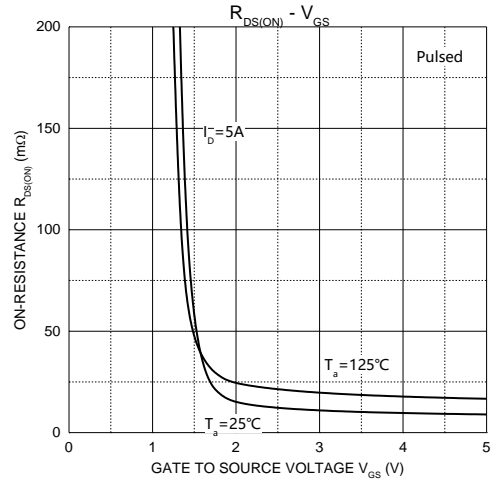
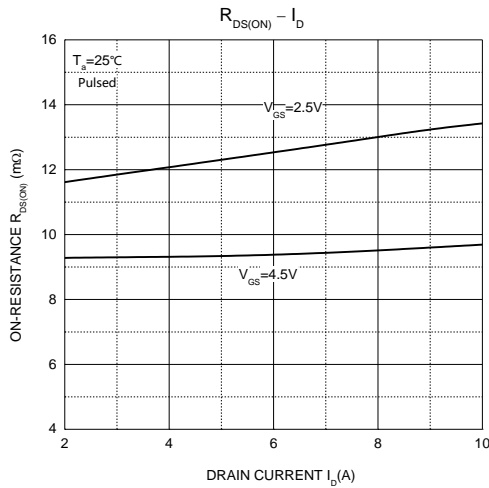
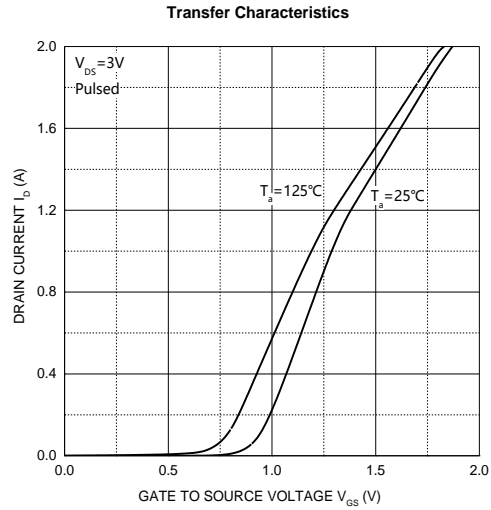
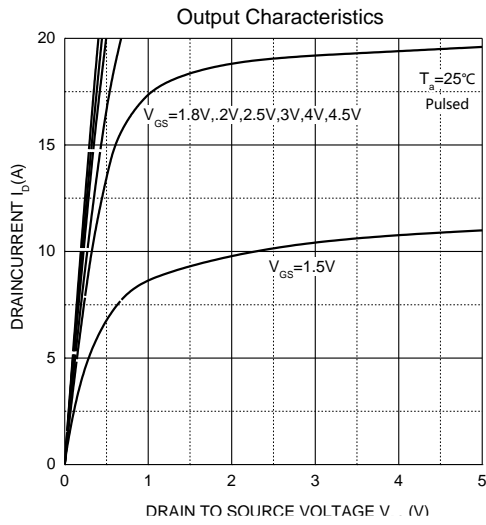

## TSSOP8 Package Information

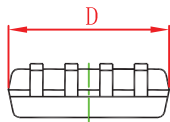
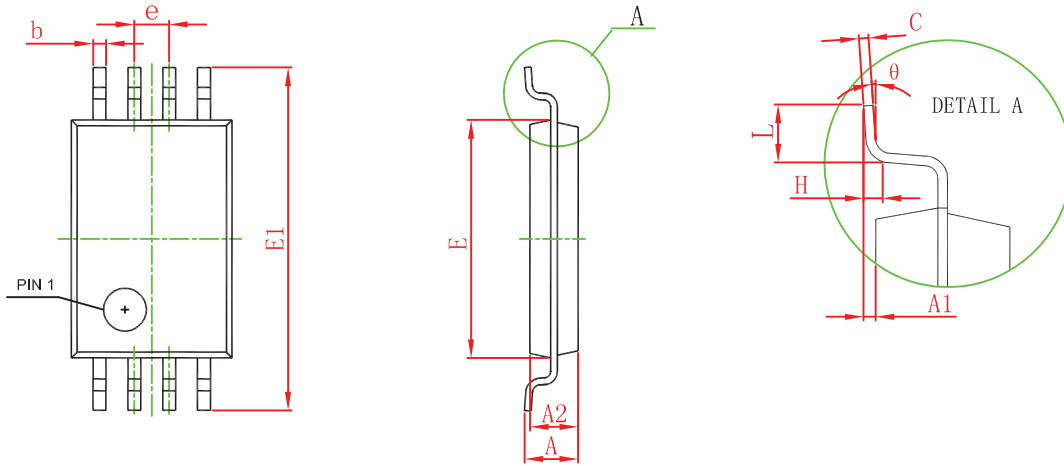

Symbol	Dimensions In Millimeters		Dimensions In Inches	
	Min	Max	Min	Max
D	2.900	3.100	0.114	0.122
E	4.300	4.500	0.169	0.177
b	0.190	0.300	0.007	0.012
c	0.090	0.200	0.004	0.008
E1	6.250	6.550	0.246	0.258
A		1.200		0.047
A2	0.800	1.000	0.031	0.039
A1	0.050	0.150	0.002	0.006
e	0.65 (BSC)		0.026 (BSC)	
L	0.500	0.700	0.020	0.028
H	0.25(TYP)		0.01(TYP)	
$\theta$	1°	7°	1°	7°

**TSSOP8 Tape and Reel**

**TSSOP8 Embossed Carrier Tape**

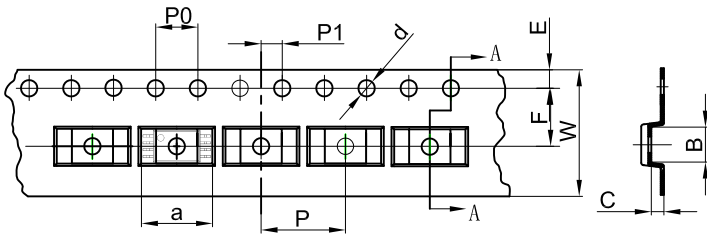

Dimensions are in millimeter										
Pkg type	a	B	C	d	E	F	P0	P	P1	W
TSSOP8	6.76	3.30	1.20	Ø1.50	1.75	5.50	4.00	8.00	2.00	12.00

**TSSOP8 Tape Leader and Trailer**

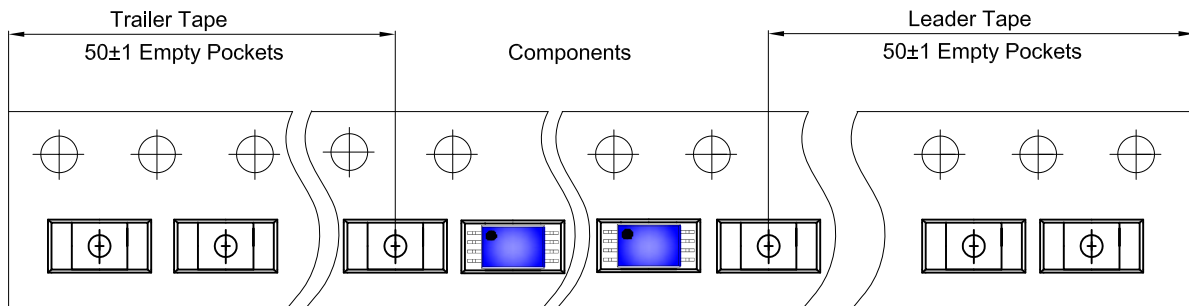

**TSSOP8 Reel**

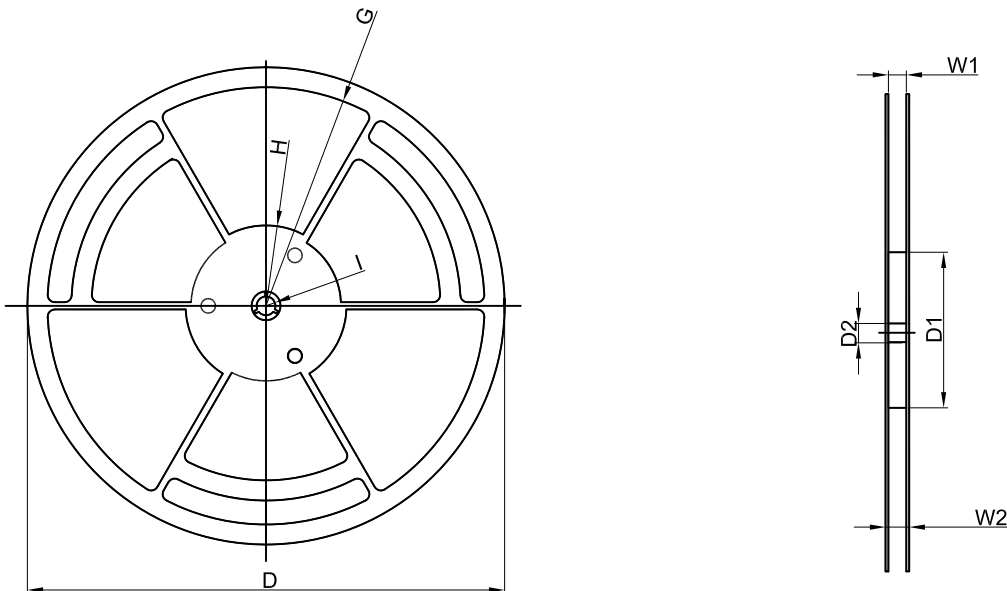

Dimensions are in millimeter								
Reel Option	D	D1	D2	G	H	I	W1	W2
13" Dia	Ø330.00	100.00	13.00	R151.00	R56.00	R6.50	12.40	17.60

REEL	Reel Size	Box	Box Size(mm)	Carton	Carton Size(mm)	G.W.(kg)
3,000 pcs	13 inch	3,000 pcs	336×336×48	24,000 pcs	445×355×365	

单击下面可查看定价，库存，交付和生命周期等信息

[>>GP\(格瑞宝\)](#)