

Product Summary

$V_{(BR)DSS}$	$R_{DS(on)TYP}$	I_D
30V	5.5mΩ@10V	35A
	7.0mΩ@4.5V	

Feature

- High cell density trench N-ch MOSFETs
- Super low gate charge
- Advanced high cell density Trench technology

Application

- High side switch in POL DC/DC converter
- Secondary side synchronous rectifier

MARKING:



AB35N03 = Device code
 Solid dot = Pin1 indicator
 XX = Date Code

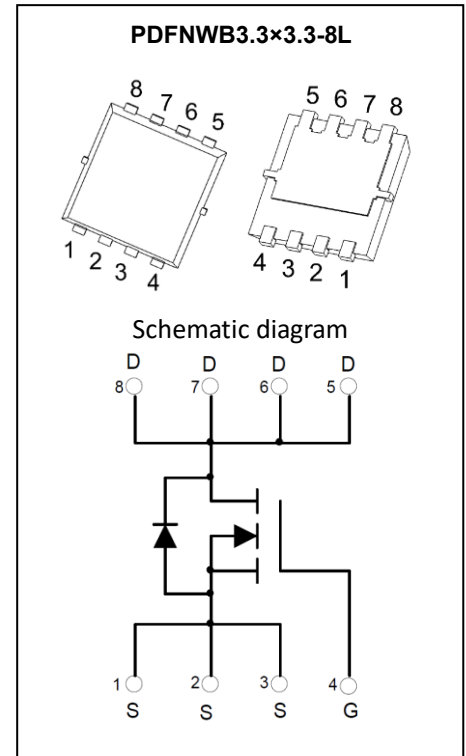

ABSOLUTE MAXIMUM RATINGS ($T_C=25^{\circ}C$ unless otherwise noted)

Parameter	Symbol	Value	Unit
Drain-Source Voltage	V_{DS}	30	V
Gate-Source Voltage	V_{GS}	±20	V
Continuous Drain Current	$I_D^{(1)}$	35	A
Pulsed Drain Current	$I_{DM}^{(1), (2)}$	120	A
Single Pulsed Avalanche Energy	E_{AS}^*	24.2	mJ
Avalanche Current	I_{AS}	22	A
Power Dissipation	$P_D^{(3)}$	1.5	W
Thermal Resistance from Junction to Ambient	$R_{\theta JA}$	83.3	$^{\circ}C/W$
Junction Temperature	T_J	150	$^{\circ}C$
Storage Temperature	T_{STG}	-55~ +150	$^{\circ}C$

* E_{AS} Test Condition $V_{DD}=15V, V_{GS}=10V, L=0.1mH, I_{AS}=22A$

MOSFET ELECTRICAL CHARACTERISTICS (T_J=25°C unless otherwise noted)

Parameter	Symbol	Test Condition	Min	Type	Max	Unit
Static Characteristics						
Drain-source breakdown voltage	V _{(BR)DSS}	V _{GS} = 0V, I _D =250μA	30			V
Zero gate voltage drain current	I _{DSS}	V _{DS} =30V, V _{GS} = 0V			-1	μA
Gate-body leakage current	I _{GSS}	V _{GS} =±20V, V _{DS} = 0V			±100	nA
Gate threshold voltage	V _{GS(th)} ⁽⁴⁾	V _{DS} =V _{GS} , I _D =250μA	1.0	1.5	3.0	V
Drain-source on-resistance	R _{DS(on)} ⁽⁴⁾	V _{GS} =10V, I _D =10A		5.5	7	mΩ
		V _{GS} =4.5V, I _D =10A		7.0	10	
Forward tranconductance	g _{FS} ⁽⁴⁾	V _{DS} =5V, I _D =20A		28		S
Dynamic characteristics⁽⁵⁾						
Input capacitance	C _{iSS}	V _{DS} =15V, V _{GS} =0V, f =1MHz		3400		pF
Output capacitance	C _{oss}			310		
Reverse transfer capacitance	C _{rSS}			250		
Switching Characteristics⁽⁵⁾						
Total gate charge	Q _g	V _{DS} =15V, V _{GS} =10V, I _D =12A		25		nC
Gate-source charge	Q _{gs}			4		
Gate-drain charge	Q _{gd}			3.6		
Turn-on delay time	t _{d(on)}	V _{DD} =15V, I _D =12A, V _{GS} =10V, R _G =6Ω			30	ns
Turn-on rise time	t _r				15	
Turn-off delay time	t _{d(off)}				40	
Turn-off fall time	t _f				20	
Diode Characteristics						
Continuous Source Current	I _S	V _G =V _D =0V , Force Current			35	A
Pulsed Source Current	I _{SM}				120	
Diode Forward Voltage	V _{SD} ⁽⁴⁾	V _{GS} =0V , I _S =10A , T _J =25°C		0.8	1.2	V

Notes:

- 1.The data tested by surface mounted on a 1 inch² FR-4 board with 2OZ c opper
- 2.Pulse Test:Pulse Width < 10us, Duty Cycle < 0.5%.
- 3.The power dissipation is limited by 150°C junction temperature
- 4.Pulse Test : Pulse width≤300μs, duty cycle≤0.5%.
- 5.Guaranteed by design, not subject to production testing.
- 6.The data is theoretically the same as I_D, in real applications , should be limited by total power dissip ation.

Typical Electrical and Thermal Characteristics

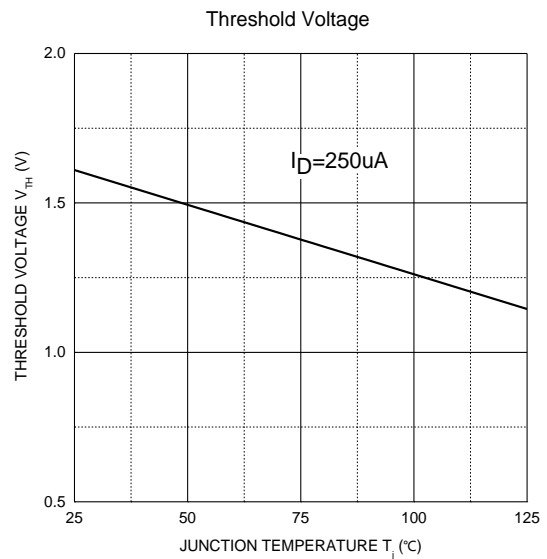
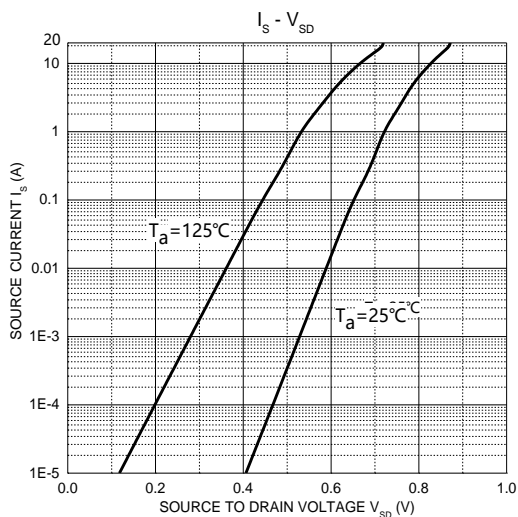
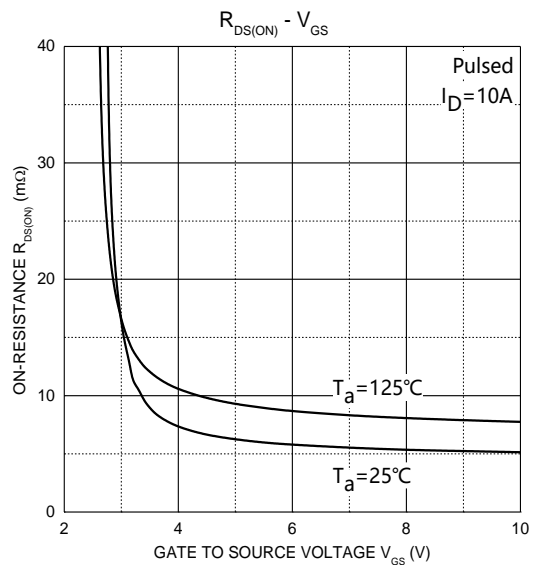
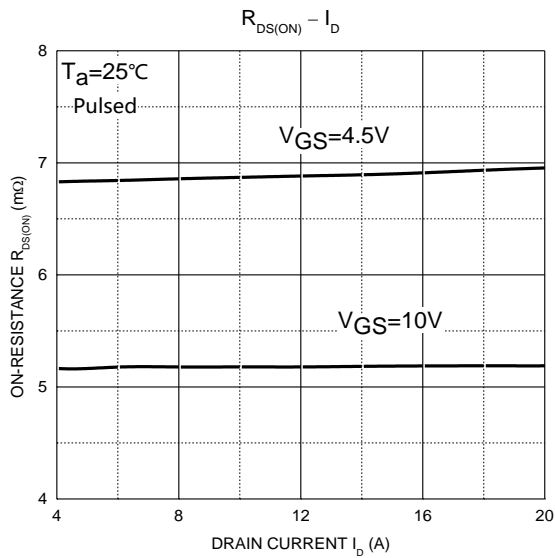
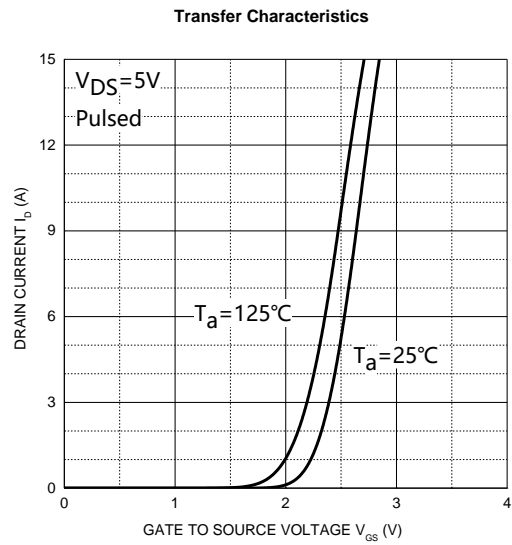
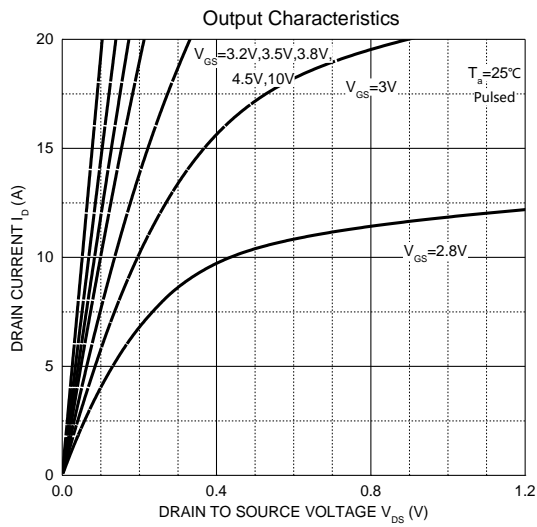

PDFNWB3.3×3.3-8L Package Information

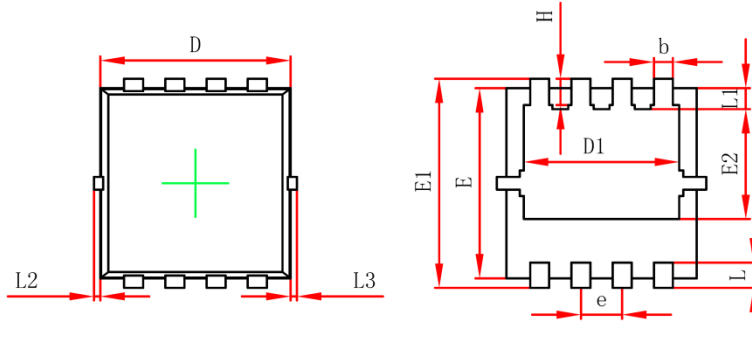

Top View
[顶视图]

Bottom View
[背视图]

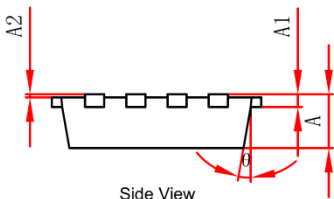

Side View
[侧视图]

Symbol	Dimensions In Millimeters		Dimensions In Inches	
	Min.	Max.	Min.	Max.
A	0.650	0.850	0.026	0.033
A1	0.152 REF.		0.006 REF.	
A2	0~0.05		0~0.002	
D	2.900	3.100	0.114	0.122
D1	2.300	2.600	0.091	0.102
E	2.900	3.100	0.114	0.122
E1	3.150	3.450	0.124	0.136
E2	1.535	1.935	0.060	0.076
b	0.200	0.400	0.008	0.016
e	0.550	0.750	0.022	0.030
L	0.300	0.500	0.012	0.020
L1	0.180	0.480	0.007	0.019
L2	0~0.100		0~0.004	
L3	0~0.100		0~0.004	
H	0.315	0.515	0.012	0.020
θ	9°	13°	9°	13°

PDFNWB3.3×3.3-8L Tape and Reel

PDFNWB3.3×3.3-8L Embossed Carrier Tape

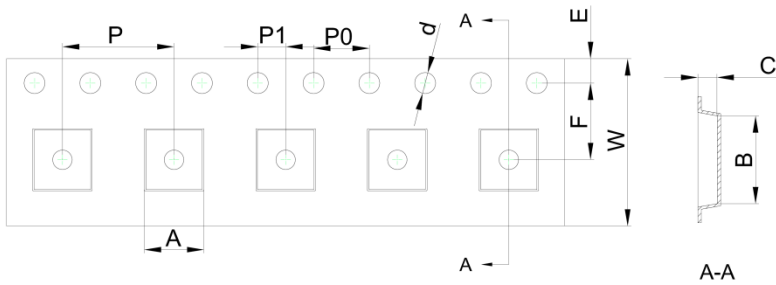

Dimensions are in millimeter										
Pkg type	A	B	C	d	E	F	P0	P	P1	W
PDFNWB3.3×3.3-8L	3.55	3.55	1.10	Ø1.50	1.75	5.50	4.00	8.00	2.00	12.00

PDFNWB3.3×3.3-8L Tape Leader and Trailer

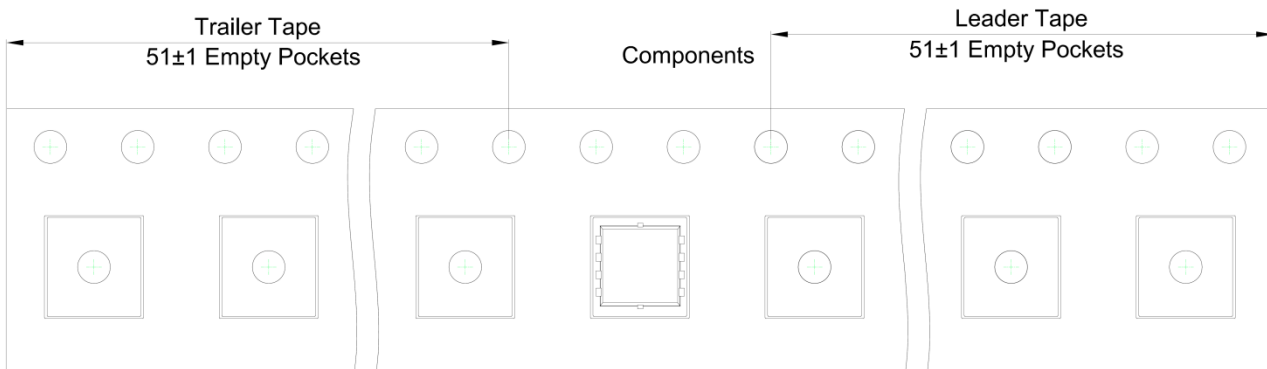

PDFNWB3.3×3.3-8L Reel

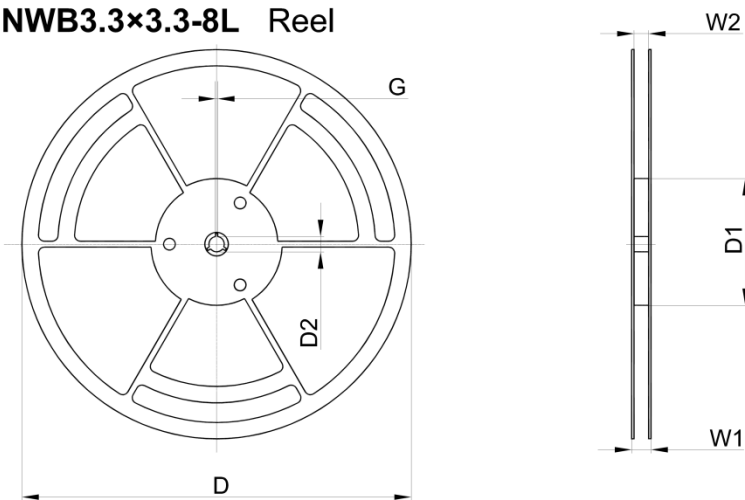

Dimensions are in millimeter						
Reel Option	D	D1	D2	G	W1	W2
13" Dia	Ø330.00	100.00	13.00	1.90	17.60	12.40

REEL	Reel Size	Box	Box Size(mm)	Carton	Carton Size(mm)
5,000 pcs	13 inch	5,000 pcs	340×336×29	50,000 pcs	353×346×365

单击下面可查看定价，库存，交付和生命周期等信息

[>>GP\(格瑞宝\)](#)