

SPECIFICATIONS FOR APPROVAL



Customer Part No.: _____ HELE. Part No: SSR025000I3CH
Application For: _____ Products: OSCILLATOR
Accepted Model: _____ Type & Freq.: HSO751S/ 25.000MHz
Sample Order No: EOS-BC0147-5 Date: 2011/12/14

Approved By :

加高電子股份有限公司
加高電子股份有限公司
HARMONY ELECTRONICS CORP.

HARMONY ELECTRONICS (THAILAND) CO., LTD.

HARMONY ELECTRONICS (SHENZHEN) CORP., LTD.

TAIPEI OFFICE:

公司:(114)
台北市內湖區堤頂大道 2 段 409 號 2 樓
2F., NO.409, SEC.2, TIDING BLVD.,
NEIHU DISTRICT, TAIPEI CITY 114,
TAIWAN (R.O.C.)
TEL:886-2-26588883
FAX:886-2-26588683

TAIWAN FACTORY:

工廠:(831)
高雄市大寮區大發工業區華東路 39 號
No.39, Hua dong Rd., Daliao Dist.,Dafa
Industrial Park., Kaohsiung City 831,
Taiwan (R.O.C.)
TEL: (07)787-1555-6
FAX: (07)787-1557

THAILAND FACTORY:

66MOO 5, KAONGU-BEOKPRAI RD.,
T.BEOKPRAI, A. BANPONG,
RAJCHABUREE PROVINCE 70110,
THAILAND
TEL: (032)221994-6, 200740-1
FAX: (032)200742

SHENZHEN FACTORY:

深圳市福永鎮塘尾村塘橋路聚源工業區
QIAO TANG RD., TANGWEI VILLAGE
FU YONG TOWN SHENZHEN CITY
CHINA
TEL: 0755-7309272 / 7309262
FAX: 0755-7309755

Title				Country of origin		
HSO751S SPECIFICATION				TAIWAN FACTORY SHEN ZHEN FACTORY		
Date	Confirm	Check	Prepare	Spec. No.	Rev.	Page
2011/12/14	F. S. TSAI	C. H. WENG	U. F. CHEN	SSR025000I3CH	0	1

HARMONY ELECTRONICS CORP.

HSO751S SPECIFICATION

INDEX

ITEM	PAGE
1. Type	3
2. Output Frequency	3
3. Absolute Maximum Ratings	3
4. Electric Specifications	3-4
5. Dimensions	5
6. Inside Structure.....	6
7. Mechanical Performance	6
8. Environment Performance	7
9. Supplement.....	8-9
10. Taping and Packing.....	9-12
11.Flow Chart.....	13
12.Environmental Workload Chemical Substance Components List	14

Title				Country of origin		
HSO751S SPECIFICATION				TAIWAN FACTORY SHEN ZHEN FACTORY		
Date	Confirm	Check	Prepare	Spec. No.	Rev.	Page
2011/12/14	F. S. TSAI	C. H. WENG	U. F. CHEN	SSR025000I3CH	0	2

HARMONY ELECTRONICS CORP.

1. Type Name :

HSO751S

2. Output Frequency :

25.000000MHz

3. Absolute Maximum Ratings :

Item	Symbol	Value	Unit
Vdd terminal voltage	Vdd	-0.5 ~ 7.0	V
Input terminal voltage	Vcont	-0.5 ~ Vdd+0.5	V
Output terminal voltage	Vout	-0.5 ~ Vdd+0.5	V
Output terminal current	Iout	25	mA
Storage temp. range	Tstr	-55 ~ 125	°C

4. Electric Specifications :

Item	Symbol	Value			Unit	Condition		
		Min	Typ	Max		Etc	Vdd	Temp
Frequency tolerance	$\Delta f/F$	-50	-	+50	ppm	Fig1,2	3.3+/- 0.3V	-10~70 °C
Operating temp. range	Topr	-10	25	+70	°C			
Supply voltage	Vdd	3.0	3.3	3.6	V			
Current consumption 1 (#1 pin: open or "H")	Idd1	-	-	25	mA	Fig1,2	3.3V	25±3°C
Current consumption 2 (#1 pin: "L" level)	Idd2	-	-	0.02	mA			
Symmetry	Duty	40	50	60	%			
Low level output voltage	Vol	-	-	0.1xVdd	V			
High level output voltage	Voh	0.9xVdd	-	-	V			
Rise & Fall time	Tr & Tf	-	-	10	ns			
Pin #1 options	YES							
Output load	C-MOS CL =30 pF (Idd1, Idd2 test at No Load)							
Low level input current	Iil	-	-	-100	μA	Fig3	3.3V	25±3°C
High Level input current	Iih	-	-	100	μA			
Low level input voltage	Vil	-	-	0.3xVdd	V			
High level input voltage	Vih	0.7xVdd	-	-	V			
Output disable time	Tplz	-	-	100	ns			
Output enable time	Tpzi	-	-	5	ms			
Aging	-	-5	-	5	ppm/year			

F :Output Frequency

Δf =Oscillation Frequency – F

Frequency Stability is inclusive of 25°C

Tolerance, operating temperature range, input voltage change,
Load chang, first of aging , shock and vibration.

Title HSO751S SPECIFICATION				Country of origin TAIWAN FACTORY SHEN ZHEN FACTORY		
Date 2011/12/14	Confirm F. S. TSAI	Check C. H. WENG	Prepare U. F. CHEN	Spec. No. SSR025000I3CH	Rev. 0	Page 3

HARMONY ELECTRONICS CORP.

Fig. 1) Measurement Circuit :

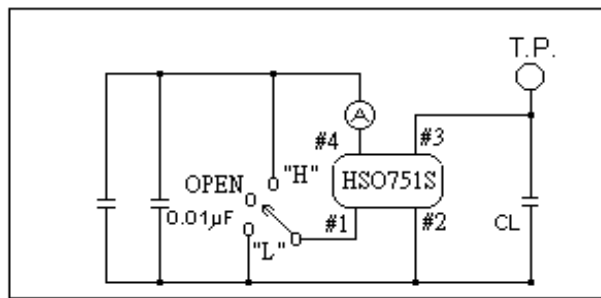

CL = Include jig & probe capacitance
(Refer to 4)

Switch	Out term.
H	Oscillation out
Open	Oscillation out
L	High Z

Fig. 2) Output Wave Form :

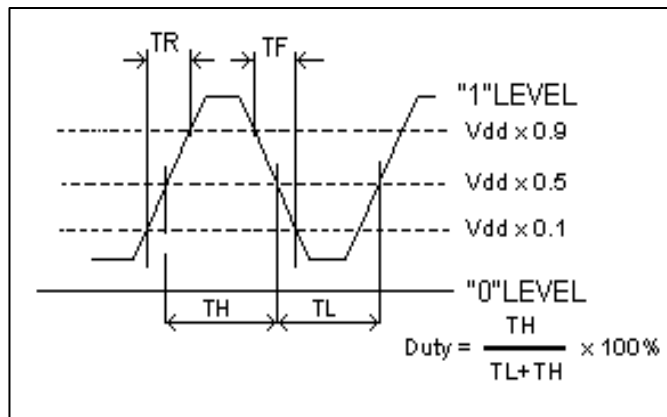
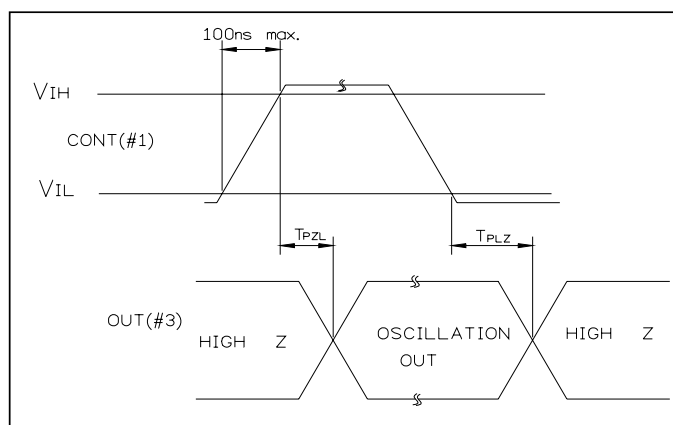

Fig. 3) Input Output Condition :



Title HSO751S SPECIFICATION				Country of origin TAIWAN FACTORY SHEN ZHEN FACTORY		
Date 2011/12/14	Confirm F. S. TSAI	Check C. H. WENG	Prepare U. F. CHEN	Spec. No. SSR025000I3CH	Rev. 0	Page 4

HARMONY ELECTRONICS CORP.

5. Dimensions :

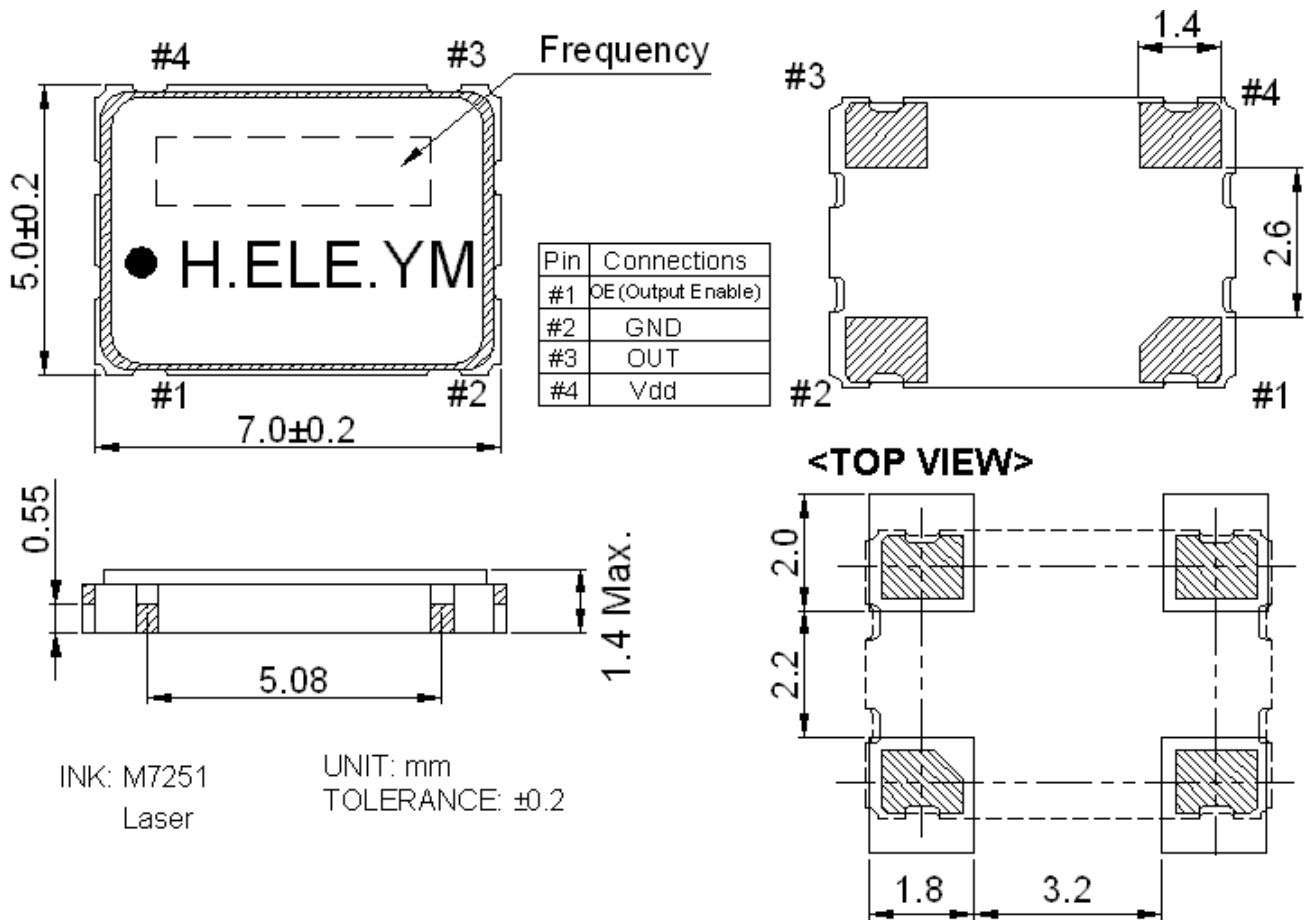

Lot No. :

Year : Last digit of the year

Year	2000	2001	2002	2003	2004	2005	2006	2007	2008	2009
	2010	2011	2012	2013	2014	2015	2016	2017	2018	2019
Code	0	1	2	3	4	5	6	7	8	9

Month : Alphabet assign below

Month	1	2	3	4	5	6	7	8	9	10	11	12
Code	A	B	C	D	E	F	G	H	J	K	L	M

Marking : Laser marking or Ink marking.

Title HSO751S SPECIFICATION				Country of origin TAIWAN FACTORY SHEN ZHEN FACTORY		
Date 2011/12/14	Confirm F. S. TSAI	Check C. H. WENG	Prepare U. F. CHEN	Spec. No. SSR025000I3CH	Rev. 0	Page 5

HARMONY ELECTRONICS CORP.

6. Inside Structure :

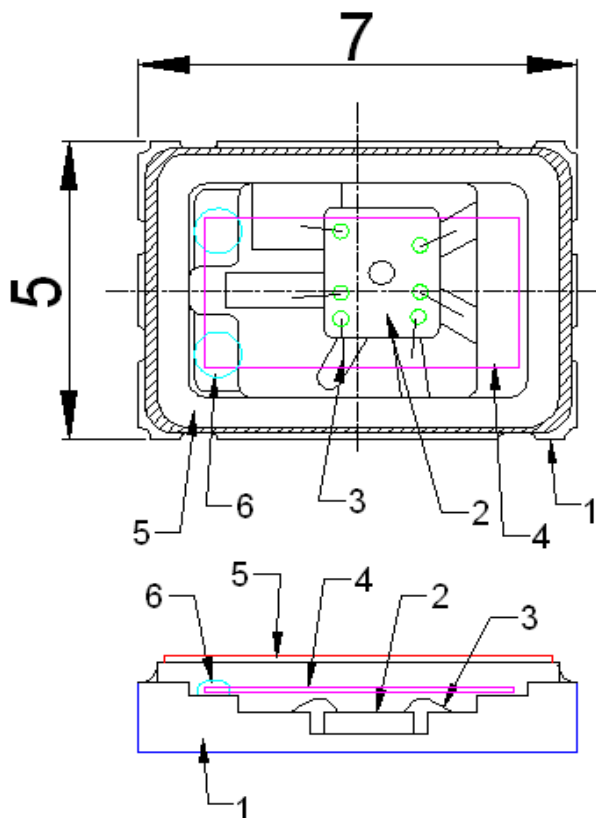

Reference drawing

(1) Base: Alumina Ceramic (Al_2O_3) Metalized Pad: W Ni Plating Au Plating
(2) IC: IC(Si. Al. Ti.)
(3) Au Bonding Wire: Au
(4) Crystal Blank Rectangular At-Cut Quartz Crystal Blank
(5) LID: Fe+Ni+Co
(6) Adhesive Silver Conductive Silicon Resin

The use prohibition chemistry substance of Table 1 of DHE-0204-1 (HE-QA-24) is not included in this item.

7. Mechanical Performance :

Item	Test Methods	Specifications Code
1	Natural Drop Drop 3 times from the height of 50cm onto min. 30mm thickness hard wooden board.	A
2	Vibration Frequency 10-55Hz, Sine Wave full amplitude of 0.8mm to X, Y and Z 3 axes, Duration of 2 hours to each axis.	A
3	Sealing Tightness Leak Rate 1.0×10^{-8} Pa-m ³ /sec. Max. Measured by Helium leak detector. – Fine Leakage.	---
4	Solderability After applying ROSIN Flux, dipping in solder bath at 245deg.C+/-5deg.C for 3+/-0.5 sec.	B

Title HSO751S SPECIFICATION				Country of origin TAIWAN FACTORY SHEN ZHEN FACTORY		
Date 2011/12/14	Confirm F. S. TSAI	Check C. H. WENG	Prepare U. F. CHEN	Spec. No. SSR025000I3CH	Rev. 0	Page 6

8. Environment Performance :

Item		Test Methods	Specifications Code
1	Humidity	Temperature 60°C +/-2°C ,RH 90~95%, Duration of 240 hours. Back to room temperature first, then in 1~2 hours, the component shall be checked.	A
2	Storage in Low Temperature	-40deg.C +/-2deg.C, Duration of 240 hours. Back to the room temperature first, then in 1~2 hours, the component shall be checked.	A
3	Storage in High Temperature	+85deg.C +/-2deg.C, Duration of 240 hours. Back to the room temperature first, then in 1~2 hours, the component shall be checked.	A
4	Temperature cycles	-30deg.C +/-2deg.C (30min) ↔ +80deg.C +/-2deg.C (30min) 25 cycles. Back to the room temperature first, then in 1~2 hours, the component shall be checked.	A
5	High Temperature Operation	+85deg.C +/-5deg.C, +3.3V Vdd Duration of 240 hours. Back to the room temperature first, then in 1~2 hours, the component shall be checked.	A

Specifications code	Test Methods
A	Frequency variation shall be within +/-5ppm and equivalent resistance shall be within the specification after the test
B	More than 90% of lead shall be covered by new solder.

Title				Country of origin		
HSO751S SPECIFICATION				TAIWAN FACTORY SHEN ZHEN FACTORY		
Date	Confirm	Check	Prepare	Spec. No.	Rev.	Page
2011/12/14	F. S. TSAI	C. H. WENG	U. F. CHEN	SSR025000I3CH	0	7

HARMONY ELECTRONICS CORP.

9. Supplement :

9.1.Soldering

9.2.Please stay with our proposed reflow condition and do then soldering 2 times max.

Available for Lead Free Soldering

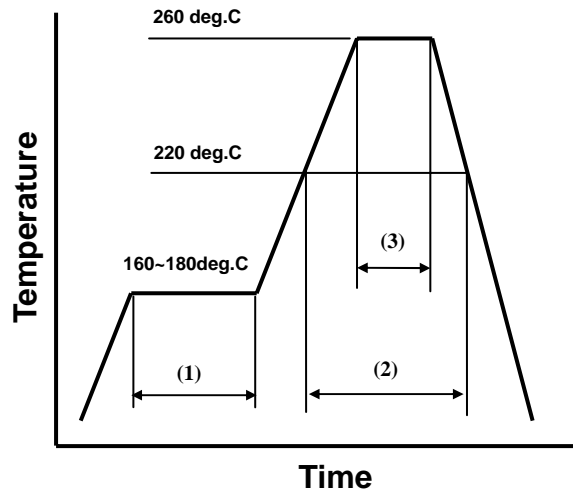

(1)	Preheat	160~180 deg.C	120sec.
(2)	Primary heat	220 deg.C	60sec.
(3)	Peak	260 deg.C	10sec. Max.

9.3.Land Pattern Layout : (Example)

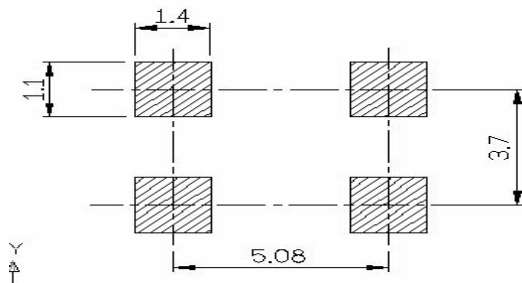

9.4.Solder Iron : (Example)

Bit temp.:350°C Max. , Time:3sec Max. , Each terminal solder a 1 time Max.

9.5.Mounting :

This component is designed for automatic insertion.

However, you are requested to do the trial with your insertion machine in order to be sure of proper operation and no damage of component.

Please pay attention to board warp which may damage the component and cause Soldering Process.

Title HSO751S SPECIFICATION				Country of origin TAIWAN FACTORY SHEN ZHEN FACTORY		
Date 2011/12/14	Confirm F. S. TSAI	Check C. H. WENG	Prepare U. F. CHEN	Spec. No. SSR025000I3CH	Rev. 0	Page 8

9.6.Cleaning :

Cleaning liquid which corrodes Nickel shall not be used.
 It may cause the problem on the surface, color, marking etc.
 Ultra-sonic cleaning is possible, however, you are requested to check on your board.
 Because we only checked as single unit.

9.7.Handling :

HSO751S series is designed to withstand Drop and Vibration, however, the crystal blank might be broken. So, if excess force is given, please check the characteristics before use.
 HSO751S series has C-MOS circuit inside. Please pay attention to static-electricity as same handling as other C-MOS. devices.

9.8.By-pass Capacitor :

It has no by-pass capacitor integrated. We recommend you to use capacitor (like ceramic chip capacitor) 0.01 μ F in-between Vdd and GND.

9.9.Storage :

Please keep away from high temperature and high humidity, which may cause put solderability. No direct Sunlight, No dew as well.

10. Taping and Packing :

10.1.Emboss Tape Specifications :

Carrier Tape

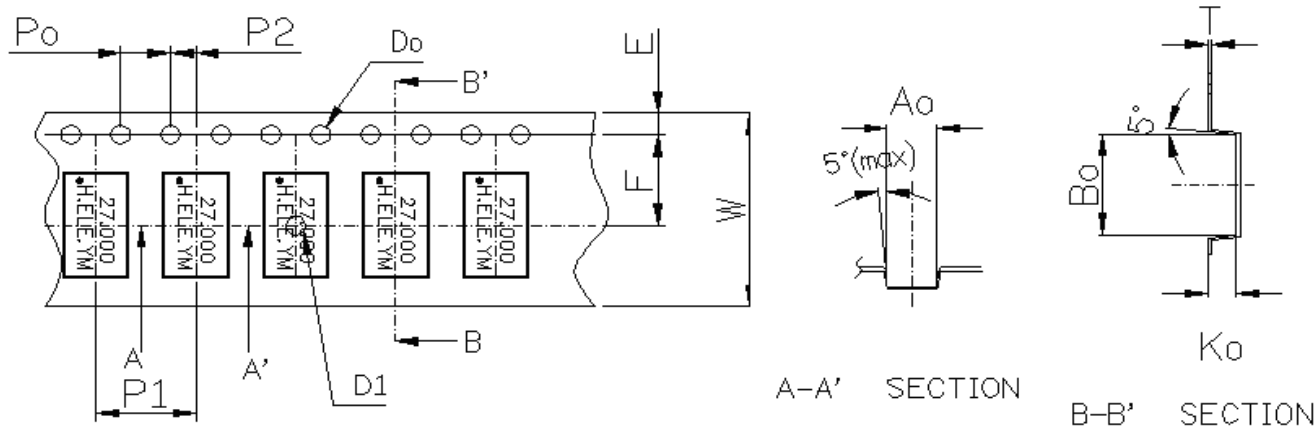

Symbol	Ao	Bo	Ko	Po	P1	P2	T
Spec	5.45±0.1	7.90±0.1	2.0±0.1	4.0±0.1	8.0±0.1	2.0±0.10	0.30±0.05
Symbol	E	F	Do	D1	W	10Po	
Spec	1.75±0.1	7.50±0.10	1.50+0.1 -0.0	1.50(min)	16.0±0.3	40.0±0.1	

Title HSO751S SPECIFICATION				Country of origin TAIWAN FACTORY SHEN ZHEN FACTORY			
Date 2011/12/14	Confirm F. S. TSAI	Check C. H. WENG	Prepare U. F. CHEN	Spec. No. SSR025000I3CH	Rev. 0	Page 9	

HARMONY ELECTRONICS CORP.

10.2.Reel Specifications :

Reel

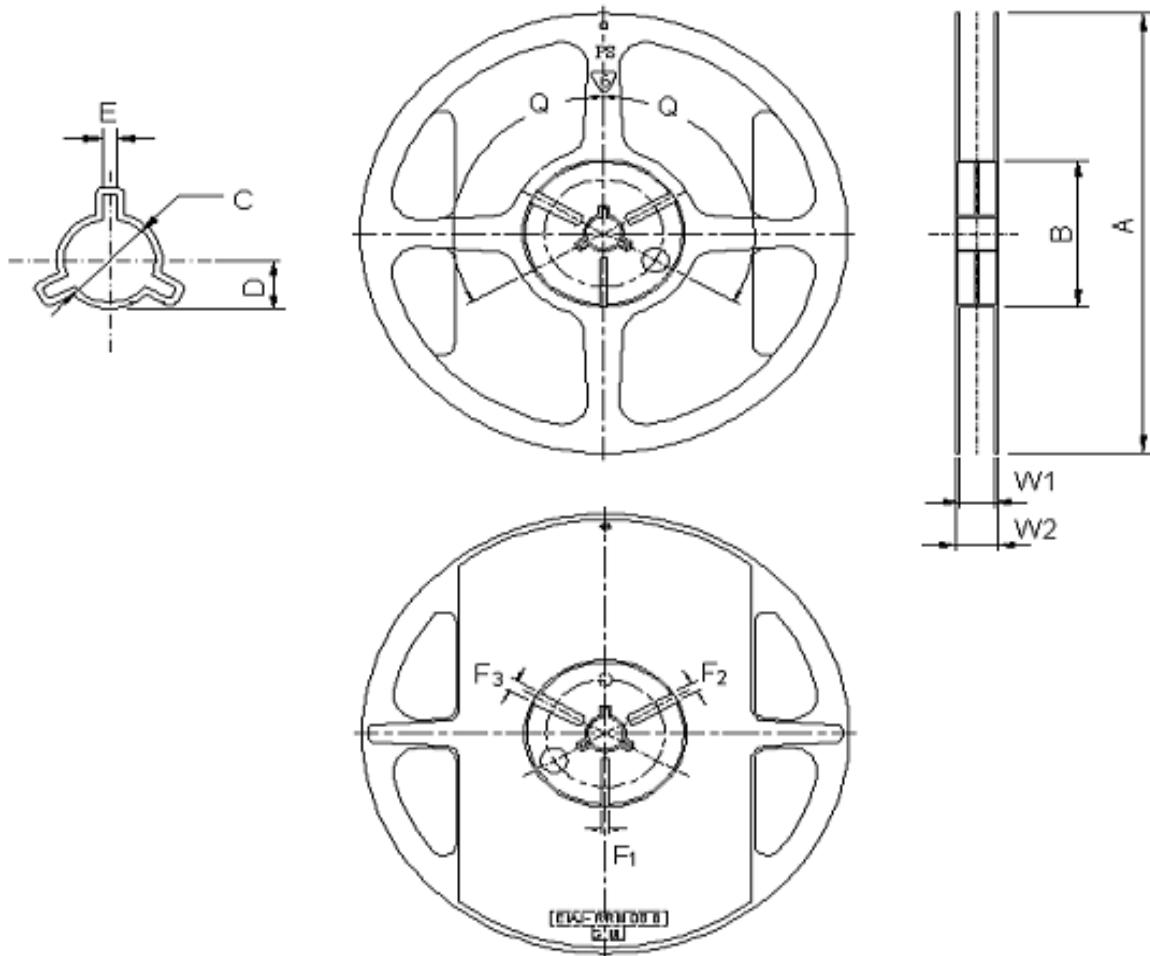

(Table-2)

(UNIT: mm)

ITEM		MARK	DIMENSIONS · ANGLE	
FLANCE	Diameter	A	$\phi 180+0/-3$	
	Inner Width	W1	$16.8+/-0.3$	
	Outer Width	W2	$19.5+/-1.0$	
HUB	Out Line diameter	B	$\phi 60.5+/-0.5$	
	Center Core slit	Width	F1	$3.0+0.5/-0$
			F2	$4.0+0.5/-0$
			F3	$5.0+0.5/-0$
	Position		q	120deg
	Spindle diameter		C	$\phi 13.2+/-0.5$
Key Ditch	Width	E	$2.4+/-0.2$	

Title HSO751S SPECIFICATION				Country of origin TAIWAN FACTORY SHEN ZHEN FACTORY		
Date 2011/12/14	Confirm F. S. TSAI	Check C. H. WENG	Prepare U. F. CHEN	Spec. No. SSR025000I3CH	Rev. 0	Page 10

HARMONY ELECTRONICS CORP.

10.3.Storage :
Temperature+40°C Max.
Humidity 80% Max.

10.4.Quantity on Reel :
1,000 PCS/REEL

10.5.Label :
Label is following information :

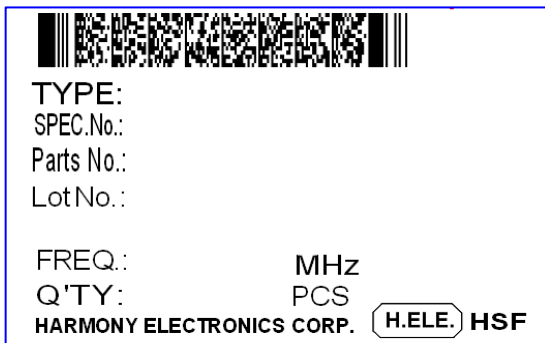

Title				Country of origin		
HSO751S SPECIFICATION				TAIWAN FACTORY SHEN ZHEN FACTORY		
Date	Confirm	Check	Prepare	Spec. No.	Rev.	Page
2011/12/14	F. S. TSAI	C. H. WENG	U. F. CHEN	SSR025000I3CH	0	11

HARMONY ELECTRONICS CORP.

10.6. PACKAGE :

1.Reel : \varnothing 180

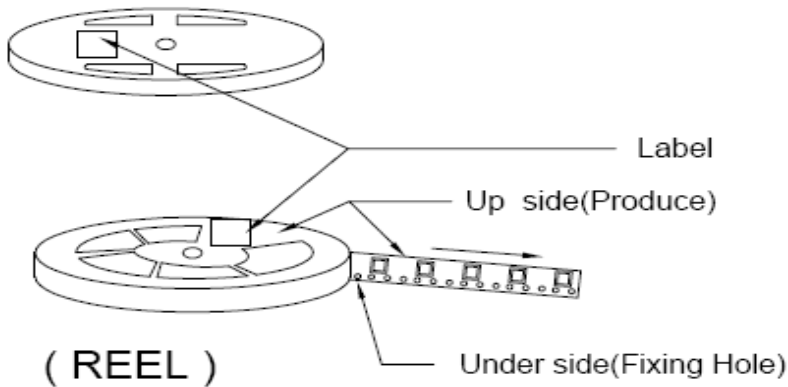

2. Carton One reel quantity:[1000pcs] &[3000pcs]

- ①Top and bottom with 2.3cm thickness foam-rubber cushion for protection.
- ②Carton's Q'TY:1~15 pcs.
- ③Carton Type=A,B,C use 4 trigon pillar to fasten the Reel.
- ④Need to add 3 pages dry agent in each outer box.

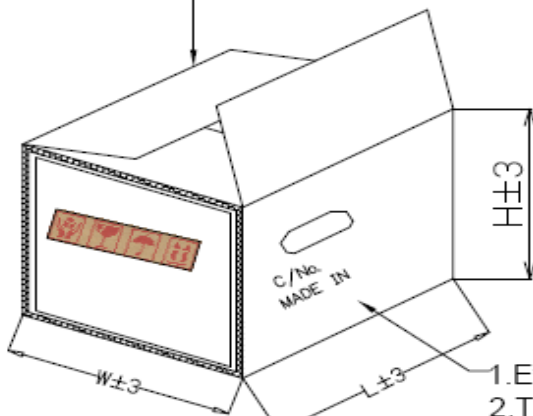
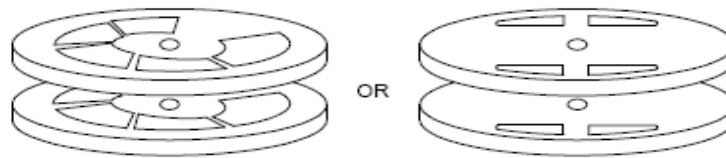

Carton Type	A	B	C	D
Produce Type	840/751	630/531/ 421	321/21	OTHER
Reel	15	15	15	1~7
L±3	200	200	200	195
W±3	200	200	200	195
H±3	230	230	230	150

(Carton)

- 1. Every Carton with 3 desiccant.
- 2. Top and bottom with 2.3cm thickness foam-rubber cushion for protection

Title HSO751S SPECIFICATION				Country of origin TAIWAN FACTORY SHEN ZHEN FACTORY		
Date 2011/12/14	Confirm F. S. TSAI	Check C. H. WENG	Prepare U. F. CHEN	Spec. No. SSR025000I3CH	Rev. 0	Page 12

HARMONY ELECTRONICS CORP.

11. Flow Chart :

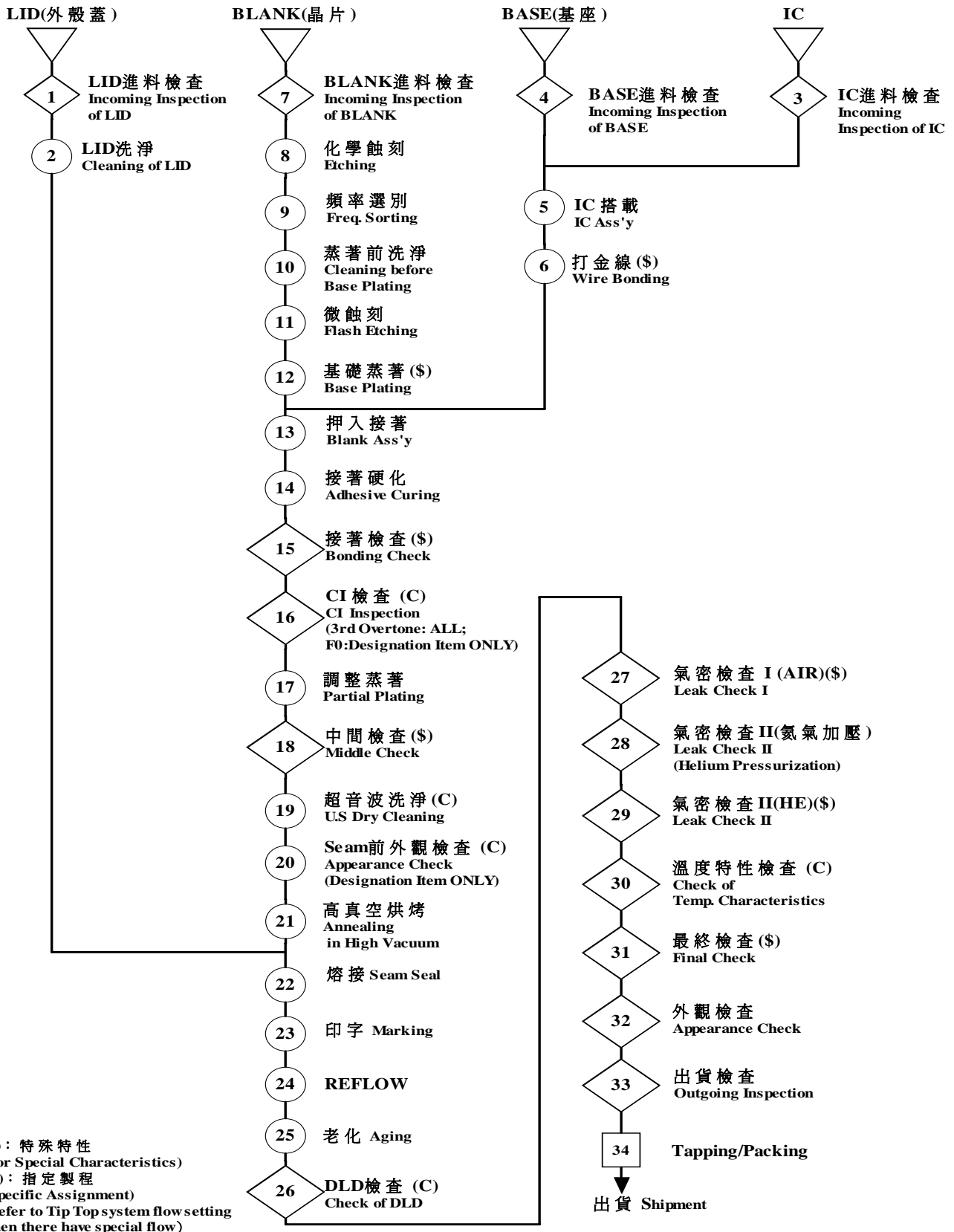

Title				Country of origin		
HSO751S SPECIFICATION				TAIWAN FACTORY SHEN ZHEN FACTORY		
Date	Confirm	Check	Prepare	Spec. No.	Rev.	Page
2011/12/14	F. S. TSAI	C. H. WENG	U. F. CHEN	SSR025000I3CH	0	13

HARMONY ELECTRONICS CORP.

12. Environmental Workload Chemical Substance Components List

Environmental Workload Chemical Substance Components List		
TYPE PERCENTAGE Chemical Substance Components	HSO751S	
	151(mg)	ppm
Si	0.8758	1322.458
Au	0.4983	752.433
Co & Co Compound	7.1725	10830.475
Mo & Mo Compound	0.4375	660.625
Ag	3.3220	5016.22
Cu	0.4983	752.433
Cr & Cr Compound	0.2718	410.418
Al	33.5069	50595.419
Mn & Mn Compound	0.1963	296.413
W & W Compound	0.9664	1459.264
Ni & Ni Compound	14.2544	21524.144
Fe	25.6096	38670.496

Title HSO751S SPECIFICATION				Country of origin TAIWAN FACTORY SHEN ZHEN FACTORY		
Date 2011/12/14	Confirm F. S. TSAI	Check C. H. WENG	Prepare U. F. CHEN	Spec. No. SSR025000I3CH	Rev. 0	Page 14

HARMONY ELECTRONICS CORP.

单击下面可查看定价，库存，交付和生命周期等信息

[>>HELE\(加高\)](#)