



# HSX221SA SPECIFICATION

## INDEX

| ITEM  | PAGE  |
|---|-------|
| <b>1. QUARTZ CRYSTAL UNIT SPECIFICATION</b> . . . . .                 | 3     |
| <b>2. MARKING &amp; DIMENSIONS</b> . . . . .                          | 4     |
| <b>3. INSIDE STRUCTURE</b> . . . . .                                  | 5     |
| <b>4. EMBOSS CARRIER TAPE&amp;REEL</b> . . . . .                      |       |
| a. DIMENSIONS OF CARRIER TAPE . . . . .                               | 6     |
| b. DIMENSIONS OF REEL . . . . .                                       | 6-7   |
| c. STORAGE CONDITION . . . . .  | 7     |
| d. STANDARD PACKING QUANTITY . . . . .                                | 7     |
| e. MATERIAL OF TAPE . . . . .   | 7     |
| f. LABEL CONTENTS . . . . .   | 7     |
| g. TAPING DIMENSION . . . . .   | 8     |
| h. JOINT OF TAPE . . . . .  | 8     |
| i. RELEASE STRENGTH OF COVER TAPE . . . . .                           | 8     |
| j. PACKAGE . . . . .  | 9     |
| <b>5. MECHANICAL ENDURANCE</b> . . . . .                              | 10    |
| <b>6. ENVIRONMENTAL ENDURANCE</b> . . . . .                           | 11    |
| <b>7. SUPPLEMENT</b> . . . . .  | 12-13 |
| <b>8. Flow Chart</b> . . . . .  | 14    |
| <b>9. Environmental Workload Chemical Substance Components List</b> . | 15    |

|  |            |           |            |  |      |      |
|--|------------|-----------|------------|--|------|------|
| Title <b>HSX221SA</b><br><b>QUARTZ CRYSTAL SPECIFICATION</b> |            |           |            | Country of origin <b>TAIWAN FACTORY</b><br><b>THAILAND FACTORY</b><br><b>CHINA FACTORY</b> |      |      |
| Date   | Confirm    | Check     | Prepare    | Spec. No.  | Rev. | Page |
| <b>2015/05/05</b>  | F. S. TSAI | Y. W. LEE | U. F. CHEN | <b>X2B02863ADC1H-W</b>   | 0    | 2    |

# 1. QUARTZ CRYSTAL UNIT SPECIFICATION

- |                                |   |
|--------------------------------|---|
| 1. Frequency:                  | 28.636360MHz  |
| 2. Holder type :               | <b>HSX221SA</b>   |
| 3. Frequency tolerance:        | +/-20 ppm at 25deg.C +/-3deg.C  |
| 4. Equivalent resistance:      | 80 ohms Max. / SERIES   |
| 5. Storage temperature range:  | -40 deg.C To +125 deg.C   |
| 6. Operable temperature range: | -20 deg.C To +70 deg.C  |
| 7. Temperature drift:          | +/-20ppm            -20 deg.C To +70 deg.C                                  |
| 8. Loading capacitance (CL) :  | 12.0 pF   |
| 9. Drive level:                | 10 $\mu$ W    (100uW Max.)  |
| 10. Shunt Capacitance:         | 2.0 pF Max.   |
| 11. Insulation resistance :    | More than 500M ohms at DC 100V  |
| 12. Mode of oscillation:       | Fundamental   |
| 13. Circuit:                   | Measured in HP/E5100A,S&A 250B  |
| 14. Shocking :                 | Dropping from 120 cm height 3 times on Concrete floor                       |
| Variation :                    | Frequency less than +/-5 ppm<br>Resistance less than +/- 15 % or 2ohms max. |
| 15. Aging:                     | Less than +/- 3 ppm/Year  |
| 16. Holder                     | HSX221SA Seam type  |
| 17. Dimensions and marking     | Refer to page.4   |
| 18. Emboss carrier tape & reel | Refer to page.6 and page.7  |
| 19. Moisture Sensitivity Level | Level 1   |
| 20. Note:                      |   |

|  |            |           |            |  |      |      |
|--|------------|-----------|------------|--|------|------|
| Title <b>HSX221SA</b><br><b>QUARTZ CRYSTAL SPECIFICATION</b> |            |           |            | Country of origin <b>TAIWAN FACTORY</b><br><b>THAILAND FACTORY</b><br><b>CHINA FACTORY</b> |      |      |
| Date   | Confirm    | Check     | Prepare    | Spec. No.  | Rev. | Page |
| <b>2015/05/05</b>  | F. S. TSAI | Y. W. LEE | U. F. CHEN | <b>X2B02863ADC1H-W</b>   | 0    | 3    |

## 2. HSX221SA MARKING & DIMENSIONS

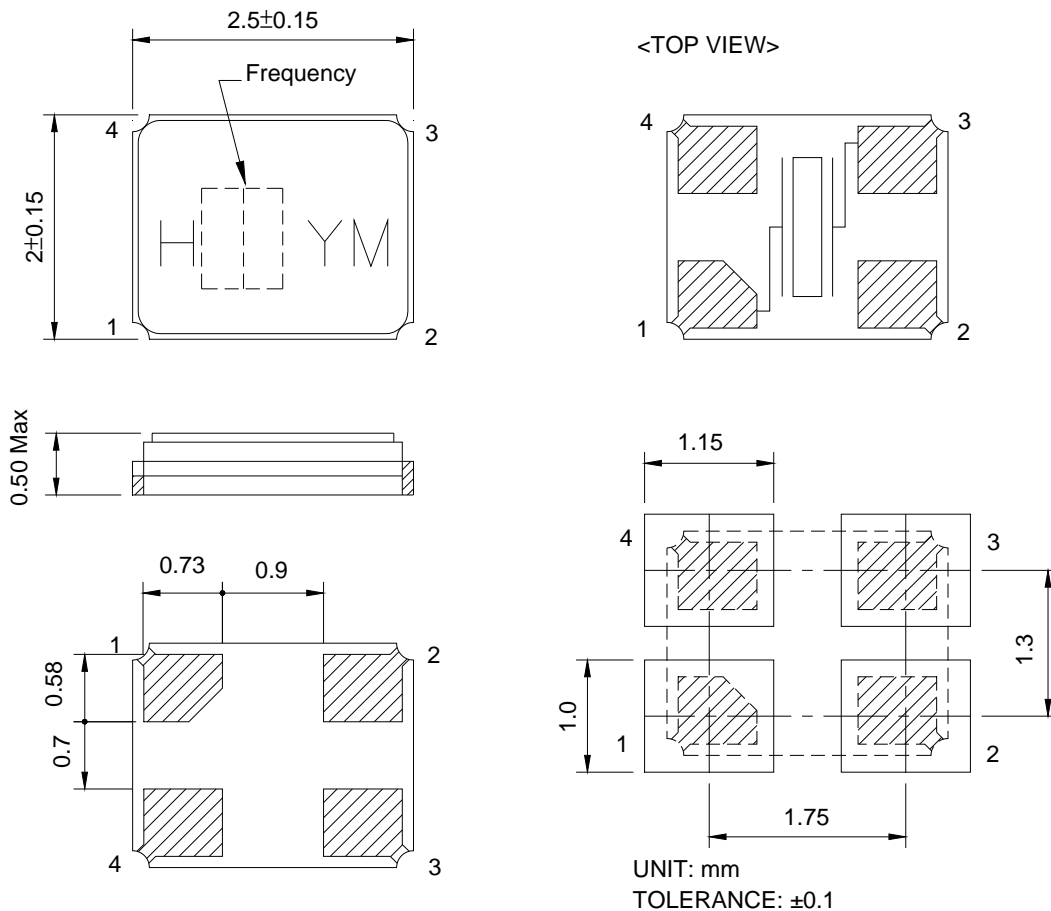

Chamfer index mark depends on the ceramic base supplier

\*Marking should be printed as following:

Logo, Nominal Frequency, Manufactured year & month

\*Nominal frequency = integer only

( ex. 14.31818 MHz → 14 )

\*Manufacturing Lot No.

(Y: year) ex. 2000 shall be marked as ' 0 ' (As shown on the Table-1)

(M: month) ex. June shall be marked as ' F ' (As shown on the Table-2).

Marking : Laser marking.

(Table-1)

|      |      |      |      |      |      |      |      |      |      |      |
|------|------|------|------|------|------|------|------|------|------|------|
| Year | 2000 | 2001 | 2002 | 2003 | 2004 | 2005 | 2006 | 2007 | 2008 | 2009 |
|      | 2010 | 2011 | 2012 | 2013 | 2014 | 2015 | 2016 | 2017 | 2018 | 2019 |
| Code | 0    | 1    | 2    | 3    | 4    | 5    | 6    | 7    | 8    | 9    |

(Table-2)

|      |      |      |      |      |      |      |      |      |      |      |      |
|------|------|------|------|------|------|------|------|------|------|------|------|
| Jan. | Feb. | Mar. | Apr. | May. | Jun. | Jul. | Aug. | Sep. | Oct. | Nov. | Dec. |
| A    | B    | C    | D    | E    | F    | G    | H    | J    | K    | L    | M    |

Title **HSX221SA**  
**QUARTZ CRYSTAL SPECIFICATION**

Country of origin **TAIWAN FACTORY**  
**THAILAND FACTORY**  
**CHINA FACTORY**

|                   |            |           |            |                        |      |      |
|-------------------|------------|-----------|------------|------------------------|------|------|
| Date              | Confirm    | Check     | Prepare    | Spec. No.              | Rev. | Page |
| <b>2015/05/05</b> | F. S. TSAI | Y. W. LEE | U. F. CHEN | <b>X2B02863ADC1H-W</b> | 0    | 4    |

### 3. INSIDE STRUCTURE

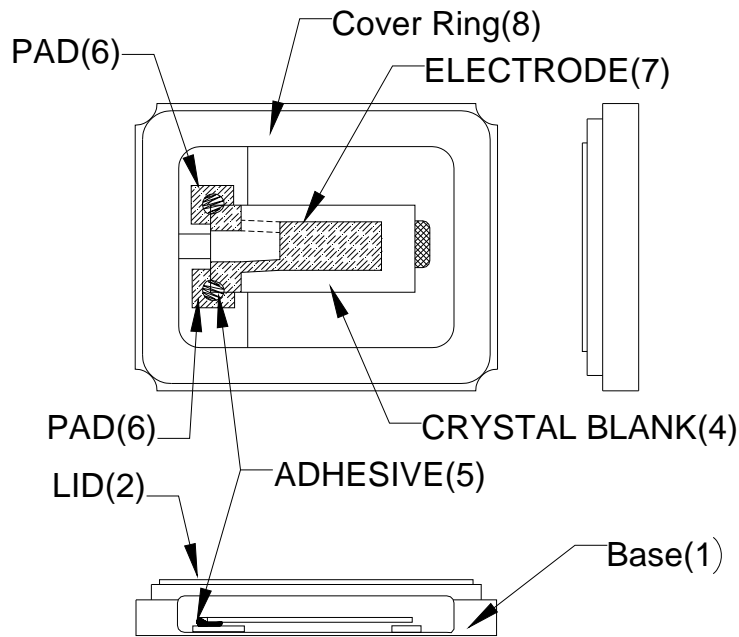

※Reference drawing

|  |
|--|
| (1) Base:<br>Alumina Ceramic (Al <sub>2</sub> O <sub>3</sub> ) |
| (6) Metallized Pad: W<br>Ni Plating<br>Au Plating              |
| (2) Lid :<br>Fe- Ni -Co  |
| (3) Crystal Enclosure Seal:<br>Seal Seam                       |
| (4) Crystal Blank<br>Rectangular At-Cut Quartz Crystal Blank   |
| (5) Adhesive<br>Silver Conductive Silicon Resin                |
| (7) Electrode  |
| (8) Cover Ring :<br>Fe-Ni-Co Alloy                             |

The use prohibition chemistry substance of Table 1 of DHE-0204-1 (HE-QA-24) is not included in this item.

|  |            |           |            |  |      |      |
|--|------------|-----------|------------|--|------|------|
| Title <b>HSX221SA</b><br><b>QUARTZ CRYSTAL SPECIFICATION</b> |            |           |            | Country of origin <b>TAIWAN FACTORY</b><br><b>THAILAND FACTORY</b><br><b>CHINA FACTORY</b> |      |      |
| Date   | Confirm    | Check     | Prepare    | Spec. No.  | Rev. | Page |
| 2015/05/05   | F. S. TSAI | Y. W. LEE | U. F. CHEN | <b>X2B02863ADC1H-W</b>   | 0    | 5    |

#### 4. HSX221SA EMBOSS CARRIER TAPE & REEL

##### a.) Dimensions of Carrier Tape

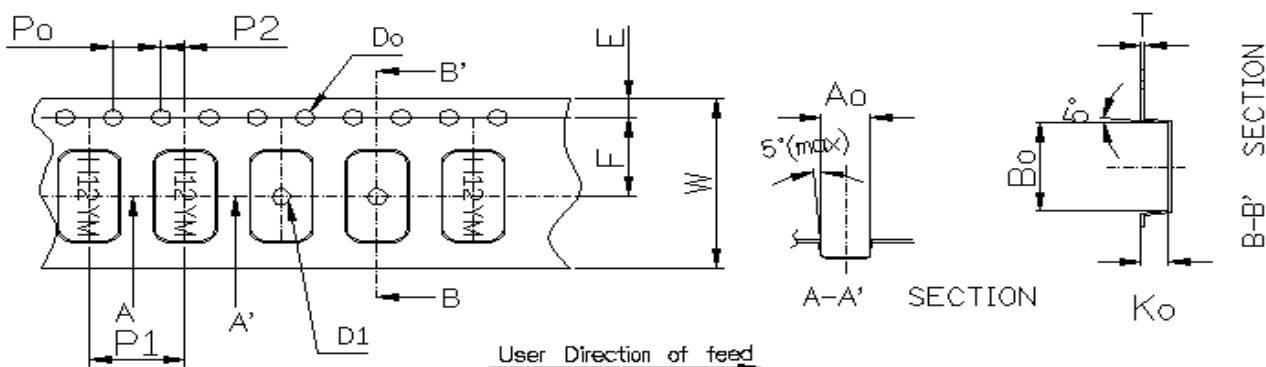

|        |                      |                      |                      |                      |                      |                      |
|--------|----------------------|----------------------|----------------------|----------------------|----------------------|----------------------|
| Symbol | <b>A<sub>0</sub></b> | <b>B<sub>0</sub></b> | <b>K<sub>0</sub></b> | <b>P<sub>0</sub></b> | <b>P<sub>1</sub></b> | <b>P<sub>2</sub></b> |
| Spec   | 2.25±0.05            | 2.7±0.05             | 0.8±0.05             | 4.0±0.1              | 4.0±0.1              | 2.0±0.05             |
| Symbol | <b>E</b>             | <b>F</b>             | <b>D<sub>0</sub></b> | <b>D<sub>1</sub></b> | <b>W</b>             | <b>T</b>             |
| Spec   | 1.75±0.1             | 3.5±0.05             | ∅1.55±0.05           | ∅1.1±0.1             | 8.0±0.2              | 0.25±0.05            |

##### b.) Dimensions of Reel

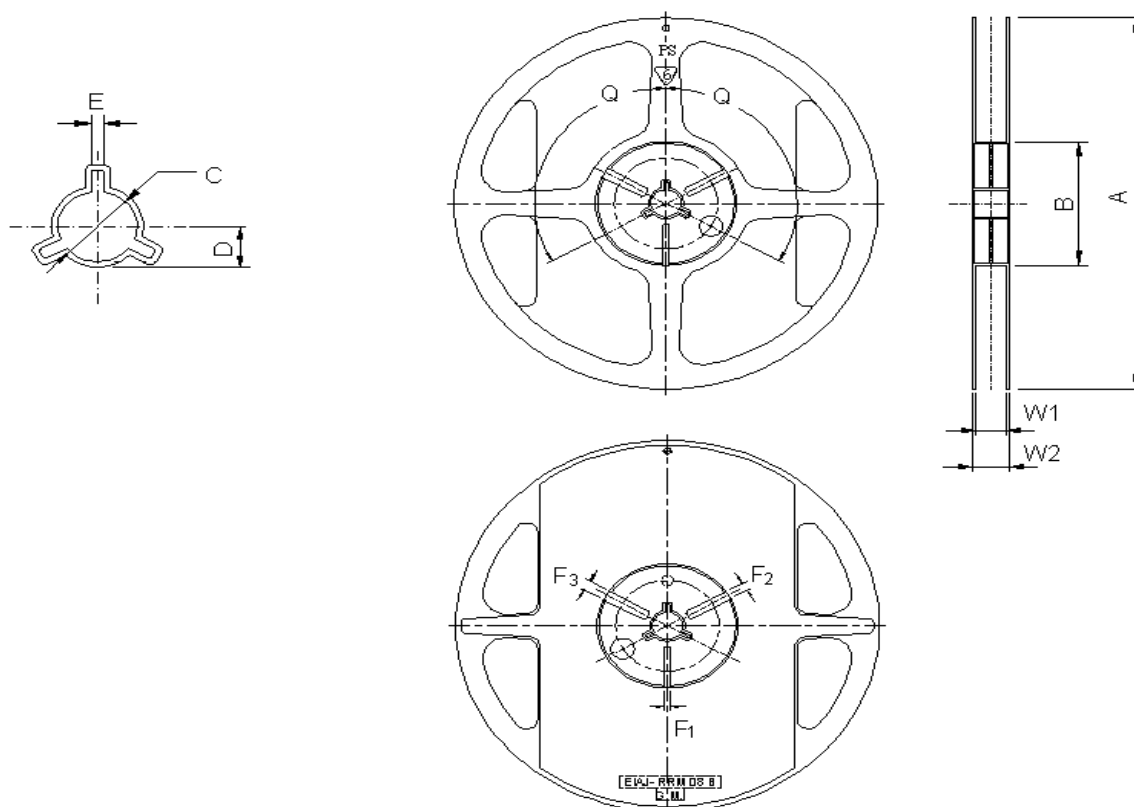

Title **HSX221SA**  
**QUARTZ CRYSTAL SPECIFICATION**

Country of origin **TAIWAN FACTORY**  
**THAILAND FACTORY**  
**CHINA FACTORY**

|            |            |           |            |                        |      |      |
|------------|------------|-----------|------------|------------------------|------|------|
| Date       | Confirm    | Check     | Prepare    | Spec. No.              | Rev. | Page |
| 2015/05/05 | F. S. TSAI | Y. W. LEE | U. F. CHEN | <b>X2B02863ADC1H-W</b> | 0    | 6    |

(Table-2)

(UNIT: mm)

| ITEM      |                   | MARK     | DIMENSIONS • ANGLE |                   |
|-----------|-------------------|----------|--------------------|-------------------|
| FLANCE    | Diameter          | A        | $\psi 180+0/-3$    |                   |
|           | Inner Width       | W1       | $9.3+/-0.3$        |                   |
|           | Outer Width       | W2       | $11.3+/-1.0$       |                   |
| HUB       | Out Line diameter | B        | $\psi 60.5+/-0.5$  |                   |
|           | Center Core slit  | Width    | F1                 | $3.0+0.5/-0$      |
|           |                   |          | F2                 | $4.0+0.5/-0$      |
|           |                   |          | F3                 | $5.0+0.5/-0$      |
|           |                   | Position | Q                  | 120deg            |
|           | Spindle diameter  |          | C                  | $\psi 13.2+/-0.5$ |
| Key Ditch | Width             | E        | $3.0+/-0.2$        |                   |

## c.) Storage condition

Temperature: +40deg.C Max.

Relative Humidity: 80% Max.



## d.) Standard packing quantity

3,000PCS / REEL

## e.) Material of the tape

| Tape         | Material      |
|--------------|---------------|
| Carrier tape | PS Conductive |
| Top tape     | Polyester     |

## f.) Label contents

|   |     |
|---|-----|
|                                |     |
| TYPE:   |     |
| SPEC.No.:   |     |
| Parts No.:  |     |
| Lot No.:  |     |
| FREQ:   | MHz |
| Q'TY:   | PCS |
| HARMONY ELECTRONICS CORP.  HSF |     |

Sticks label for every reel.

Title **HSX221SA**  
**QUARTZ CRYSTAL SPECIFICATION**

Country of origin **TAIWAN FACTORY**  
**THAILAND FACTORY**  
**CHINA FACTORY**

| Date       | Confirm    | Check     | Prepare    | Spec. No.              | Rev. | Page |
|------------|------------|-----------|------------|------------------------|------|------|
| 2015/05/05 | F. S. TSAI | Y. W. LEE | U. F. CHEN | <b>X2B02863ADC1H-W</b> | 0    | 7    |

g.) Taping dimension

|          |              |   |
|----------|--------------|---|
| Leader   | Cover-tape   | The length of cover-tape in the leader is more than 400 mm including empty embossed area.   |
|          | Carrier-tape | After all products were packaged, must remain more than twenty pieces or 400 mm empty area, which should be sealed by cover-tape. |
| Terminal | Cover-tape   | The tip of cover-tape shall be fixed temporary by paper tape and roll around the core of reel one round.                          |
|          | Carrier-tape | The empty embossed area which are sealed by top cover-tape must remain more the 40 mm.  |

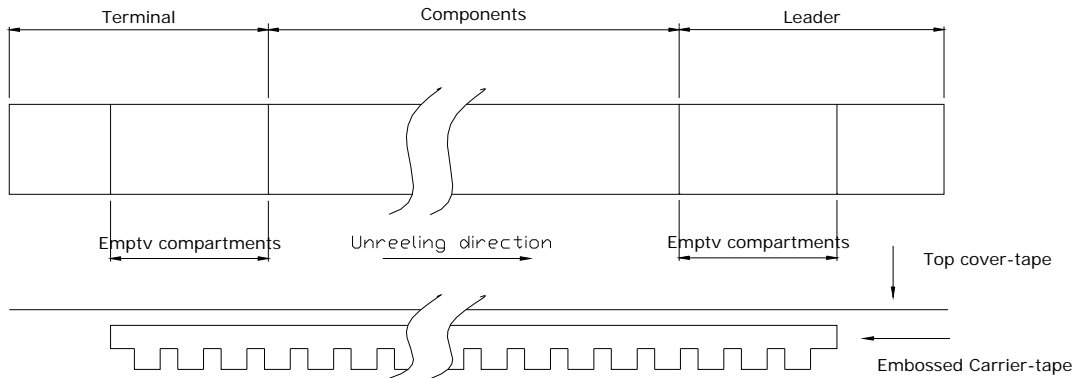

h.) Joint of tape

The carrier-tape and top cover-tape should not be jointed.

i.) Release strength of cover tape

It has to between 0.1N to 0.7N under following condition.

Pulling direction 165° to 180°

Speed 300mm/min.

Otherwise unless specified.

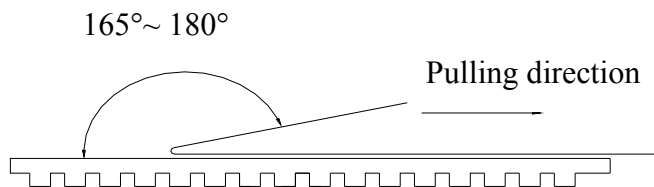

Other standards shall be based on JIS C 0806-1990.

|  |            |           |            |  |      |      |
|--|------------|-----------|------------|--|------|------|
| Title <b>HSX221SA</b><br><b>QUARTZ CRYSTAL SPECIFICATION</b> |            |           |            | Country of origin <b>TAIWAN FACTORY</b><br><b>THAILAND FACTORY</b><br><b>CHINA FACTORY</b> |      |      |
| Date   | Confirm    | Check     | Prepare    | Spec. No.  | Rev. | Page |
| <b>2015/05/05</b>  | F. S. TSAI | Y. W. LEE | U. F. CHEN | <b>X2B02863ADC1H-W</b>   | 0    | 8    |



j.) Package

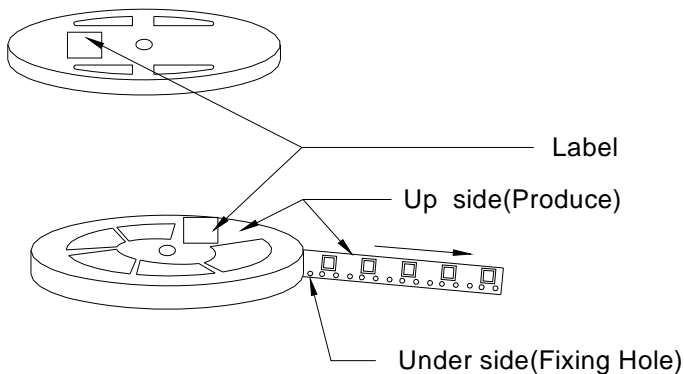

One reel quantity: [1000pcs]&[3000pcs]

- ① Top and bottom with 2.3cm thickness foam-rubber cushion for protection.
- ② Carton's Q'TY: 1~15 pcs.
- ③ Carton Type=A,B,C use 4 trigon pillar to fasten the Reel.
- ④ Need to add 3 pages dry agent in each outer box.

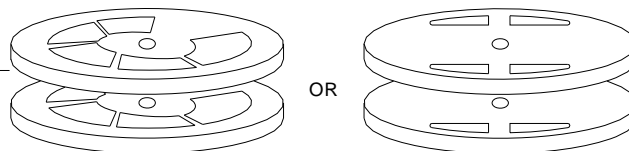
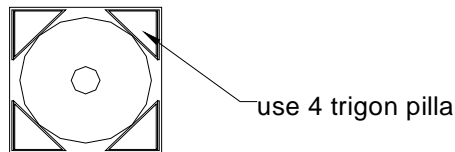

Green Product  
ROHS Compliant

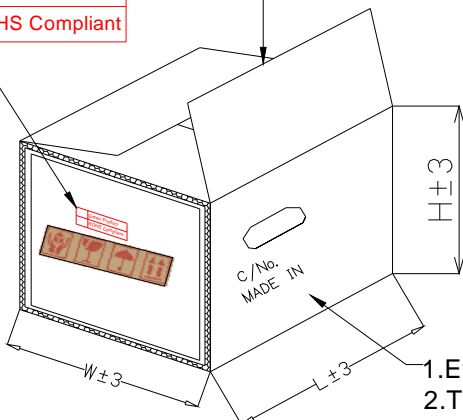

| Carton Type  | A       | B               | C                  | D     |
|--------------|---------|-----------------|--------------------|-------|
| Produce Type | 840/751 | 630/531/<br>421 | 321/221<br>211/111 | OTHER |
| Reel         | 15      | 15              | 15                 | 1~7   |
| L±3          | 200     | 200             | 200                | 195   |
| W±3          | 200     | 200             | 200                | 195   |
| H±3          | 230/260 | 230             | 230                | 150   |

- 1. Every Carton with 3 desiccant.
- 2. Top and bottom with 2.3cm thickness foam-rubber cushion for protection

Title **HSX221SA**  
**QUARTZ CRYSTAL SPECIFICATION**

Country of origin **TAIWAN FACTORY**  
**THAILAND FACTORY**  
**CHINA FACTORY**

| Date       | Confirm    | Check     | Prepare    | Spec. No.              | Rev. | Page |
|------------|------------|-----------|------------|------------------------|------|------|
| 2015/05/05 | F. S. TSAI | Y. W. LEE | U. F. CHEN | <b>X2B02863ADC1H-W</b> | 0    | 9    |

## 5. Mechanical Performance

| Item |                   | Test Methods   | Specifications Code |
|------|-------------------|--|---------------------|
| 1    | Natural Drop      | Dropping from 120 cm height 3 times on Concrete floor<br>Refer to: JIS C 60068-2-6   | A                   |
| 2    | Vibration         | Frequency 10-55Hz, Sine Wave full amplitude of 0.8mm to X, Y and Z<br>3 axes, Duration of 2 hours to each axis.<br>Refer to: MIL-HDBK-781A 6.5.2/ JIS C 60068-2-6  | A                   |
| 3    | Sealing Tightness | Leak Rate $1.0 \times 10^{-8}$ Pa-m <sup>3</sup> /sec. Max. Measured by Helium leak detector.  | ---                 |
| 4    | Solder ability    | After applying ROSIN Flux, dipping in solder bath at 245deg.C +/- 5deg.C for 3 +/- 0.5 sec.<br>Refer to: JIS C 60068-2-20  | B                   |
| 5    | Substrate Bending | Mount a sample on board.<br>Apply Pressure to the center of board until it is bent to 3 mm and hold for $5 \pm 1$ sec<br>Pressure speed : 0.5 mm / sec<br>Refer to: EIAJ ET-7403                             | A                   |
| 6    | Adhesion          | Mount a sample on the circuit board.<br>Apply pressure vertically to the side of specimen attached to the circuit board with the pressure jig.<br>Pressure : 5N for $10 \pm 1$ sec<br>Refer to: EIAJ ET-7403 | A                   |
| 7    | Body strength     | Apply pressure to the center of body with the R0.5 pressure jig.<br>pressure : 10N for $10 \pm 1$ sec<br>Refer to: EIAJ ET-7403  | A                   |

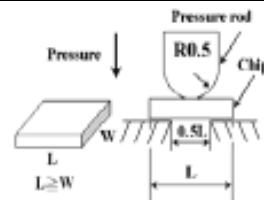
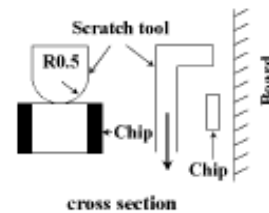
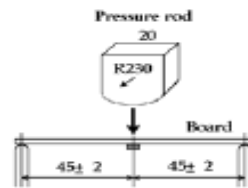

Title **HSX221SA**  
**QUARTZ CRYSTAL SPECIFICATION**

Country of origin **TAIWAN FACTORY**  
**THAILAND FACTORY**  
**CHINA FACTORY**

|            |            |           |            |                        |      |      |
|------------|------------|-----------|------------|------------------------|------|------|
| Date       | Confirm    | Check     | Prepare    | Spec. No.              | Rev. | Page |
| 2015/05/05 | F. S. TSAI | Y. W. LEE | U. F. CHEN | <b>X2B02863ADC1H-W</b> | 0    | 10   |

## 6. Environment Performance

| Item |                             | Test Methods  | Specifications Code |
|------|-----------------------------|---|---------------------|
| 1    | Humidity                    | Temperature 60°C +/-2°C, RH 90~95%, Duration of 240 hours.<br>Back to room temperature first, then in 1~2 hours, the component shall be checked.<br>Refer to: JIS C 60068-2-3     | A                   |
| 2    | Storage in Low Temperature  | -40deg.C +/-2deg.C, Duration of 240 hours.<br>Back to the room temperature first, then in 1~2 hours, the component shall be checked.<br>Refer to: JIS C 60068-2-1                 | A                   |
| 3    | Storage in High Temperature | +85deg.C +/-2deg.C, Duration of 240 hours.<br>Back to the room temperature first, then in 1~2 hours, the component shall be checked.<br>Refer to: JIS C 60068-2-2                 | A                   |
| 4    | Temperature cycles          | -40deg.C +/-2deg.C (30min) ↔ +85deg.C +/-2deg.C (30min) 25 cycles. Back to the room temperature first, then in 1~2 hours, the component shall be checked.<br>Refer to: JIS C 0025 | A                   |

| Specifications code | Specifications   |
|---------------------|--|
| A                   | Frequency variation shall be within +/-5ppm and equivalent resistance shall be within +/-15% or 2Ω |
| B                   | More than 90% of lead shall be covered by new solder.  |
|                     |  |

|  |            |           |            |  |      |      |
|--|------------|-----------|------------|--|------|------|
| Title <b>HSX221SA</b><br><b>QUARTZ CRYSTAL SPECIFICATION</b> |            |           |            | Country of origin <b>TAIWAN FACTORY</b><br><b>THAILAND FACTORY</b><br><b>CHINA FACTORY</b> |      |      |
| Date   | Confirm    | Check     | Prepare    | Spec. No.  | Rev. | Page |
| 2015/05/05   | F. S. TSAI | Y. W. LEE | U. F. CHEN | <b>X2B02863ADC1H-W</b>   | 0    | 11   |

## 7. Supplement

### 7.1.Soldering

7.2.Please stay with our proposed reflow condition and do then soldering 2 times max.

**Available for Lead Free Soldering**

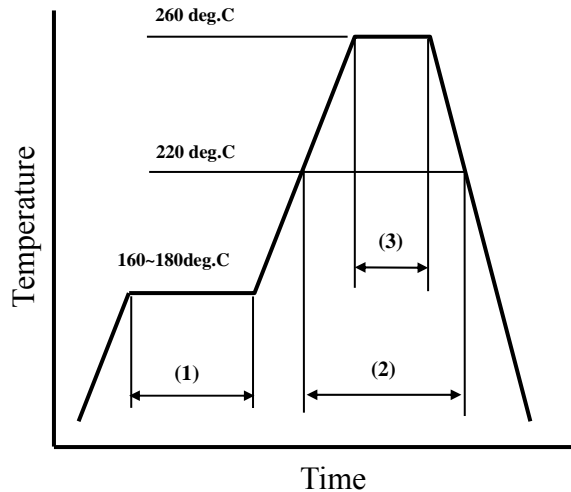

|     |              |               |             |
|-----|--------------|---------------|-------------|
| (1) | Preheat      | 160~180 deg.C | 120sec.     |
| (2) | Primary heat | 220 deg.C     | 60sec.      |
| (3) | Peak         | 260 deg.C     | 10sec. Max. |

### 7.3.Land pattern layout(Example)

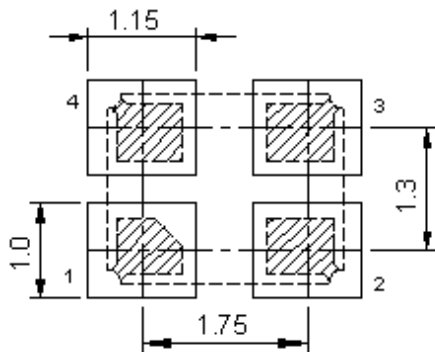

### 7.4.Solder iron (Example)

Bit temp.: 350°C max., Time:3sec max. , Each terminal solder a 1 time max.

Title **HSX221SA**  
**QUARTZ CRYSTAL SPECIFICATION**

Country of origin **TAIWAN FACTORY**  
**THAILAND FACTORY**  
**CHINA FACTORY**

| Date       | Confirm    | Check     | Prepare    | Spec. No.              | Rev. | Page |
|------------|------------|-----------|------------|------------------------|------|------|
| 2015/05/05 | F. S. TSAI | Y. W. LEE | U. F. CHEN | <b>X2B02863ADC1H-W</b> | 0    | 12   |

### 7.5.Mounting

This component is designed for automatic insertion.  
However, you are requested to do the trial with your insertion machine in order to be Sure of proper operation and no damage of component.  
Please pay attention to board warp which may damage the component and cause Soldering process.  
Avoid mounting and processing by Ultrasonic welding because this method has a Possibility of an excessive vibration spreading inside the crystal products and Becoming the cause of characteristic deterioration and not oscillating.

### 7.6.Cleaning

Cleaning liquid which corrodes Nickel shall not be used  
It may cause the problem on the surface, color, marking etc.  
Ultra-sonic cleaning is possible, however, you are requested to check on your board.  
Because we only checked as single unit.

### 7.7.Storage

Please keep away from high temperature and high humidity, which may cause put solderbility.  
No direct Sunlight, No dew as well.

|  |            |           |            |  |      |      |
|--|------------|-----------|------------|--|------|------|
| Title <b>HSX221SA</b><br><b>QUARTZ CRYSTAL SPECIFICATION</b> |            |           |            | Country of origin <b>TAIWAN FACTORY</b><br><b>THAILAND FACTORY</b><br><b>CHINA FACTORY</b> |      |      |
| Date   | Confirm    | Check     | Prepare    | Spec. No.  | Rev. | Page |
| <b>2015/05/05</b>  | F. S. TSAI | Y. W. LEE | U. F. CHEN | <b>X2B02863ADC1H-W</b>   | 0    | 13   |

## 8. Flow Chart

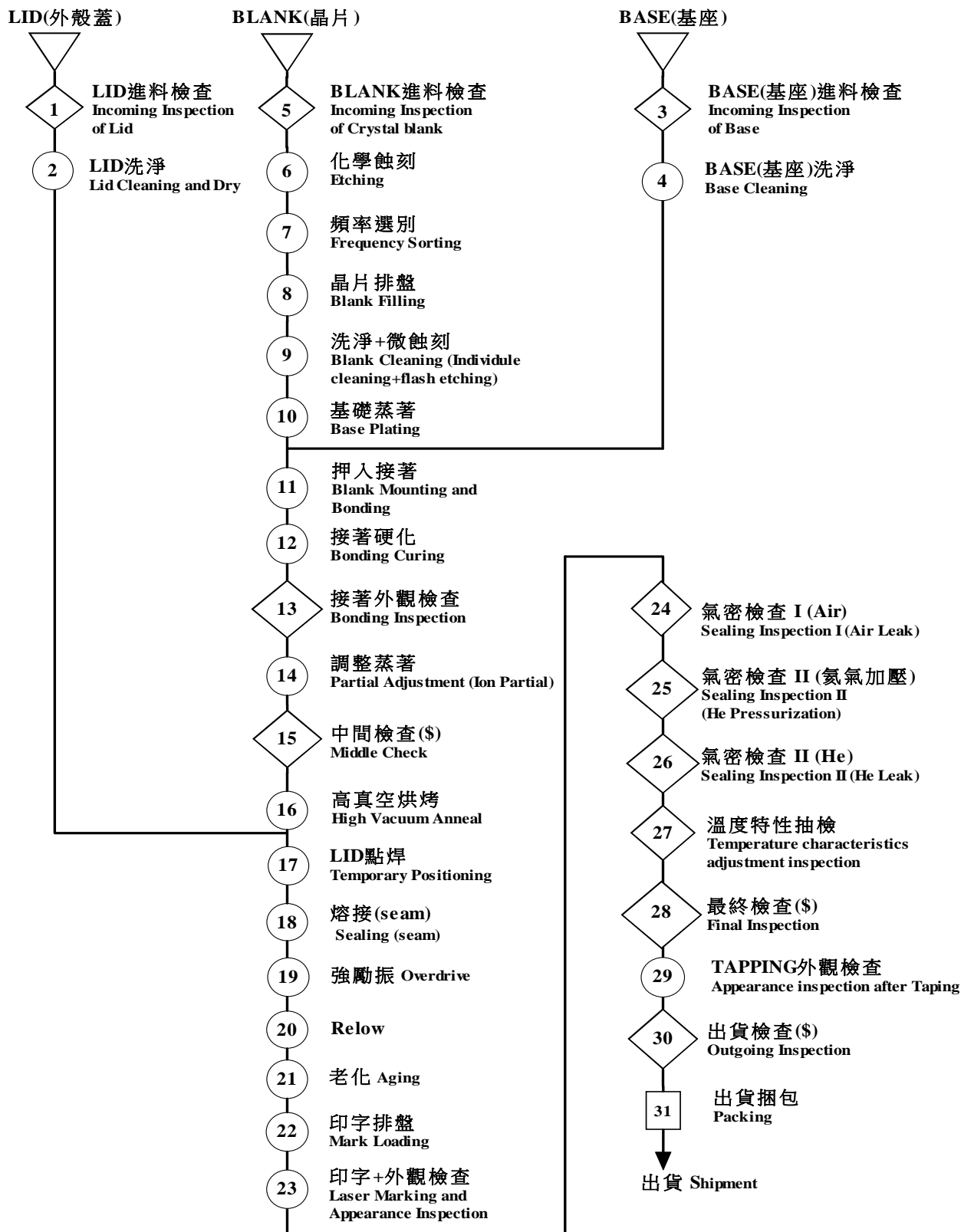

(\$) : 特殊特性  
(For Critical process had been monitored)

|  |            |           |            |  |      |      |
|--|------------|-----------|------------|--|------|------|
| Title <b>HSX221SA</b><br><b>QUARTZ CRYSTAL SPECIFICATION</b> |            |           |            | Country of origin <b>TAIWAN FACTORY</b><br><b>THAILAND FACTORY</b><br><b>CHINA FACTORY</b> |      |      |
| Date   | Confirm    | Check     | Prepare    | Spec. No.  | Rev. | Page |
| 2015/05/05   | F. S. TSAI | Y. W. LEE | U. F. CHEN | <b>X2B02863ADC1H-W</b>   | 0    | 14   |

9. Environmental Workload Chemical Substance Components List

| Environmental Workload Chemical Substance Components List |          |            |
|---|----------|------------|
| TYPE<br><br>PERCENTAGE                                    | HSX221S  |            |
|   | 9.6(mg)  | ppm        |
| Chemical Substance Components                             |          |            |
| Si  | 0.316800 | 30.412800  |
| Au  | 0.048000 | 4.608000   |
| Co & Co Compound  | 0.784320 | 75.294720  |
| Mo & Mo Compound  | 0.017280 | 1.658880   |
| Ag  | 1.875840 | 180.080640 |
| Cu  | 0.075840 | 7.280640   |
| Cr & Cr Compound  | 0.024000 | 2.304000   |
| Al  | 2.083200 | 199.987200 |
| Mn & Mn Compound  | 0.014400 | 1.382400   |
| W & W Compound  | 0.042240 | 4.055040   |
| Ni & Ni Compound  | 2.090880 | 200.724480 |
| Fe  | 2.220480 | 213.166080 |

|  |            |           |            |  |      |      |
|--|------------|-----------|------------|--|------|------|
| Title <b>HSX221SA</b><br><b>QUARTZ CRYSTAL SPECIFICATION</b> |            |           |            | Country of origin <b>TAIWAN FACTORY</b><br><b>THAILAND FACTORY</b><br><b>CHINA FACTORY</b> |      |      |
| Date   | Confirm    | Check     | Prepare    | Spec. No.  | Rev. | Page |
| 2015/05/05   | F. S. TSAI | Y. W. LEE | U. F. CHEN | <b>X2B02863ADC1H-W</b>   | 0    | 15   |





单击下面可查看定价，库存，交付和生命周期等信息

[>>HELE\(加高\)](#)