

## Features

- Complies with JEDEC standard no. 7A
- CMOS input levels
- Synchronous counting and loading
- 2 count enable inputs for n-bit cascading
- Asynchronous reset
- Positive-edge triggered clock
- ESD protection:  
HBM JESD22-A114F exceeds 2000 V  
MM JESD22-A115-A exceeds 200 V
- Multiple package options
- Specified from -40 °C to +85 °C

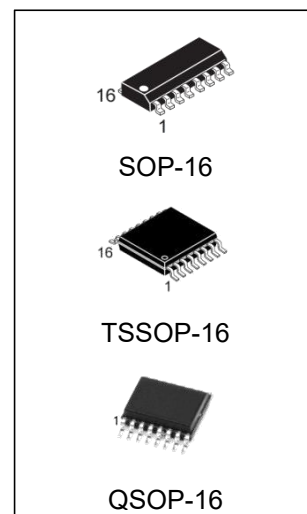

## Ordering Information

DEVICE	Package Type	MARKING	Packing	Packing Qty
74HC161DRG	SOP-16	74HC161	REEL	2500pcs/reel
74HC161PWRG	TSSOP-16	HC161	REEL	2500pcs/reel
74HC161DBRG	QSOP-16	HC161	REEL	2500pcs/reel

## General description

The 74HC161 is a synchronous presettable binary counter with an internal look-ahead carry. Synchronous operation is provided by having all flip-flops clocked simultaneously on the positivegoing edge of the clock (CP). The outputs (Q0 to Q3) of the counters may be preset HIGH or LOW.

A LOW at the parallel enable input (PE) disables the counting action and causes the data at the data inputs (D0 to D3) to be loaded into the counter on the positive-going edge of the clock. Preset takes place regardless of the levels at count enable inputs (CEP and CET). A LOW at the master reset input (MR) sets Q0 to Q3 LOW regardless of the levels at input pins CP, PE, CET and CEP (thus providing an asynchronous clear function). The look-ahead carry simplifies serial cascading of the counters. Both CEP and CET must be HIGH to count. The CET input is fed forward to enable the terminal count output (TC). The TC output thus enabled will produce a HIGH output pulse of a duration approximately equal to a HIGH output of Q0. This pulse can be used to enable the next cascaded stage. The maximum clock frequency for the cascaded counters is determined by the CP to TC propagation delay and CEP to CP set-up time, according to the following formula:

$$F_{\max} = \frac{1}{t_{p(\max)}(\text{CPtoTC}) + t_{\text{SU}}(\text{CEPtoCP})}$$

Inputs include clamp diodes. This enables the use of current limiting resistors to interface inputs to voltages in excess of  $V_{CC}$ .

## Functional diagram

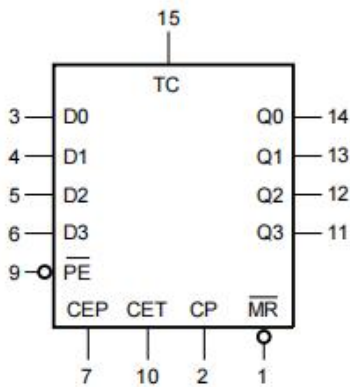

Fig.1.Logic symbol

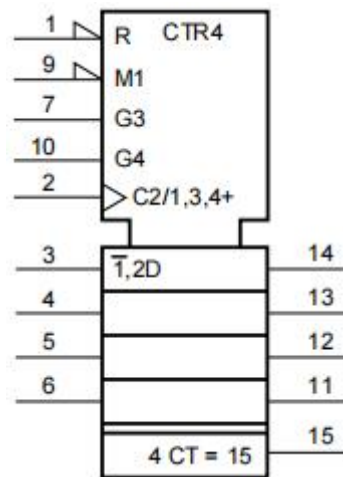

Fig.2.IEC logic symbol

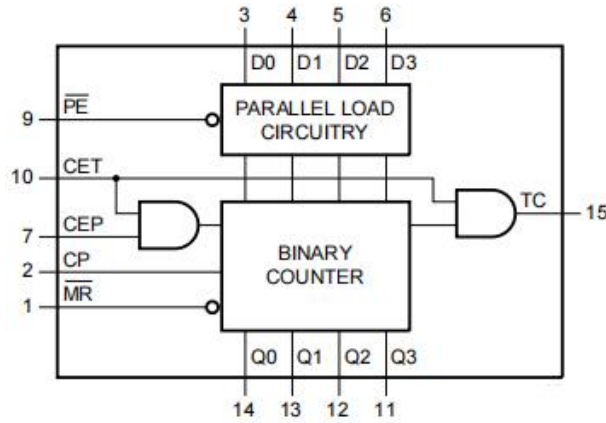

Fig. 3. Functional diagram

**Presetable synchronous 4-bit binary counter; asynchronous reset**

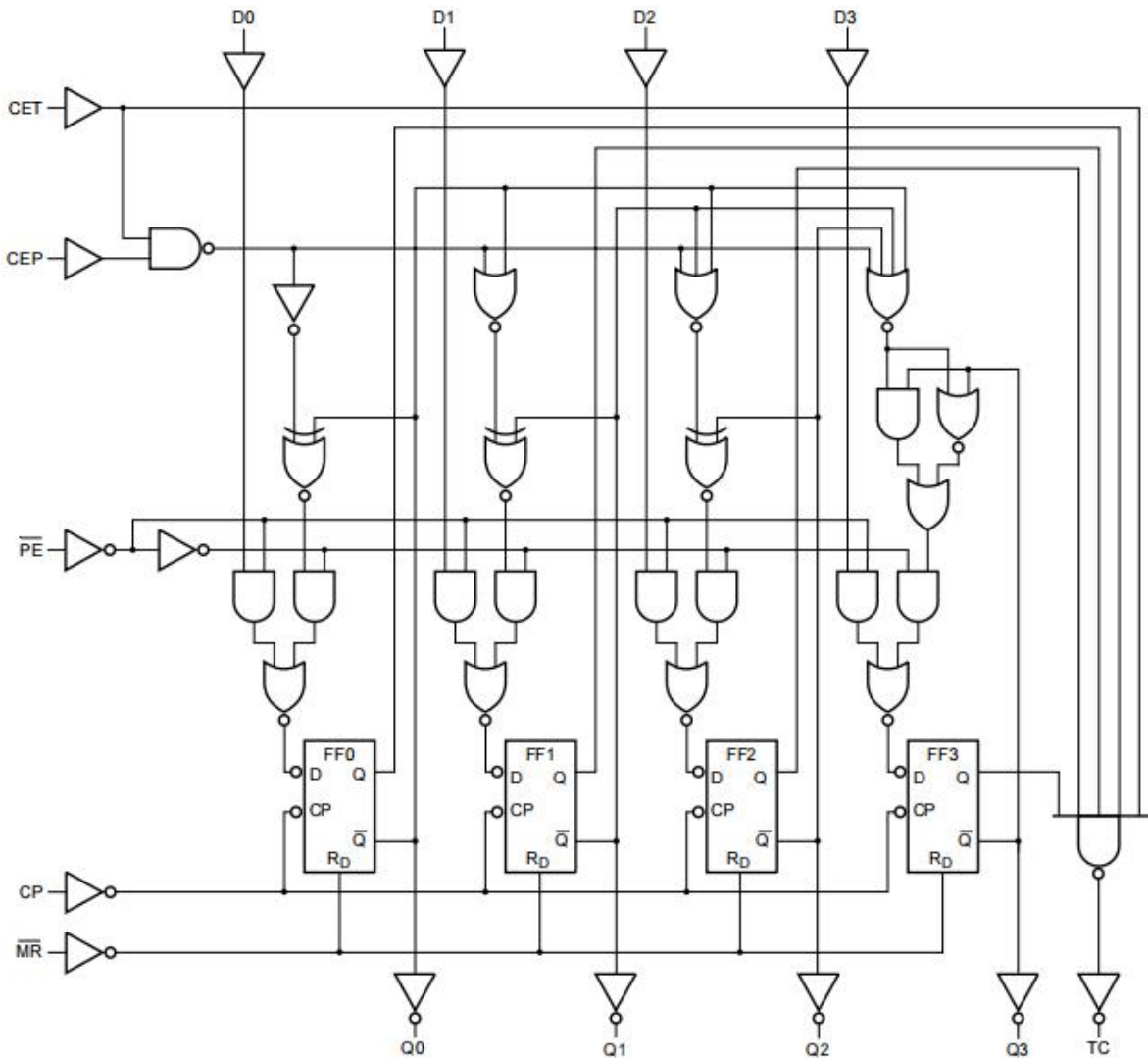

Fig. 4. Logic diagram

## Pin Configuration

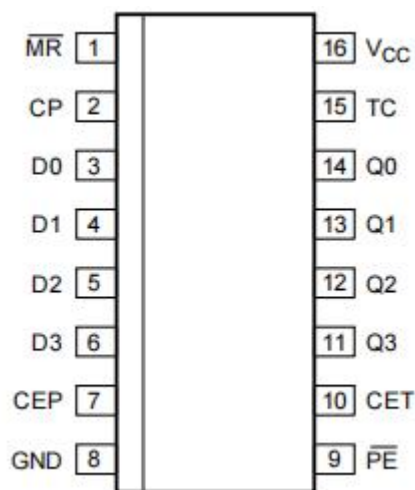

Fig 5. Pin configuration SOP-16

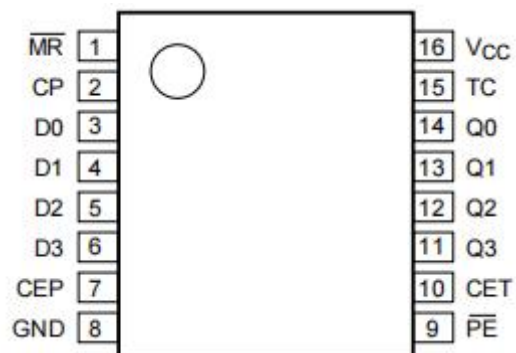

Fig 6. Pin configuration QSOP-16 and TSSOP-16

## Pin description

Symbol	Pin	Description
$\overline{MR}$	1	asynchronous master reset (active LOW)
CP	2	clock input (LOW-to-HIGH, edge-triggered)
D0, D1, D2, D3	3, 4, 5, 6	data input
CEP	7	count enable input
GND	8	ground (0 V)
PE	9	parallel enable input (active LOW)
CET	10	count enable carry input
Q0, Q1, Q2, Q3	14, 13, 12, 11	flip-flop output
TC	15	terminal count output
VCC	16	supply voltage

**Function table[1]**

Operating modes	Input						Output	
	MR	CP	CEP	CET	PE	Dn	Qn	TC
Reset (clear)	L	X	X	X	X	X	L	L
Parallel load	H	↑	X	X	l	l	L	L
	H	↑	X	X	l	h	H	[2]
Count	H	↑	h	h	h	X	count	[2]
Hold (do nothing)	H	X	l	X	h	X	qn	[2]
	H	X	X	l	h	X	qn	L

1. H = HIGH voltage level

h = HIGH voltage level one set-up time prior to the LOW-to-HIGH clock transition L = LOW voltage level

l = LOW voltage level one set-up time prior to the LOW-to-HIGH clock transition

qn = lower case letters indicate the state of the referenced output one set-up time prior to the LOW-to-HIGH clock transition

X = don't care

↑ = LOW-to-HIGH clock transition

2. The TC output is HIGH when CET is HIGH and the counter is at terminal count (HHHH)

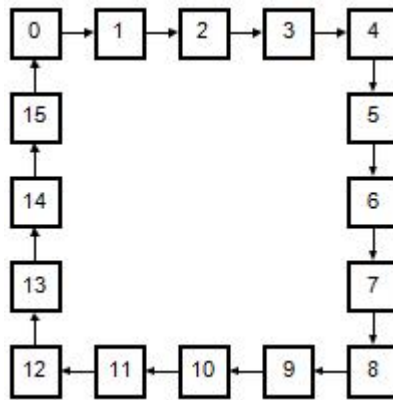

**Fig. 7. State diagram**

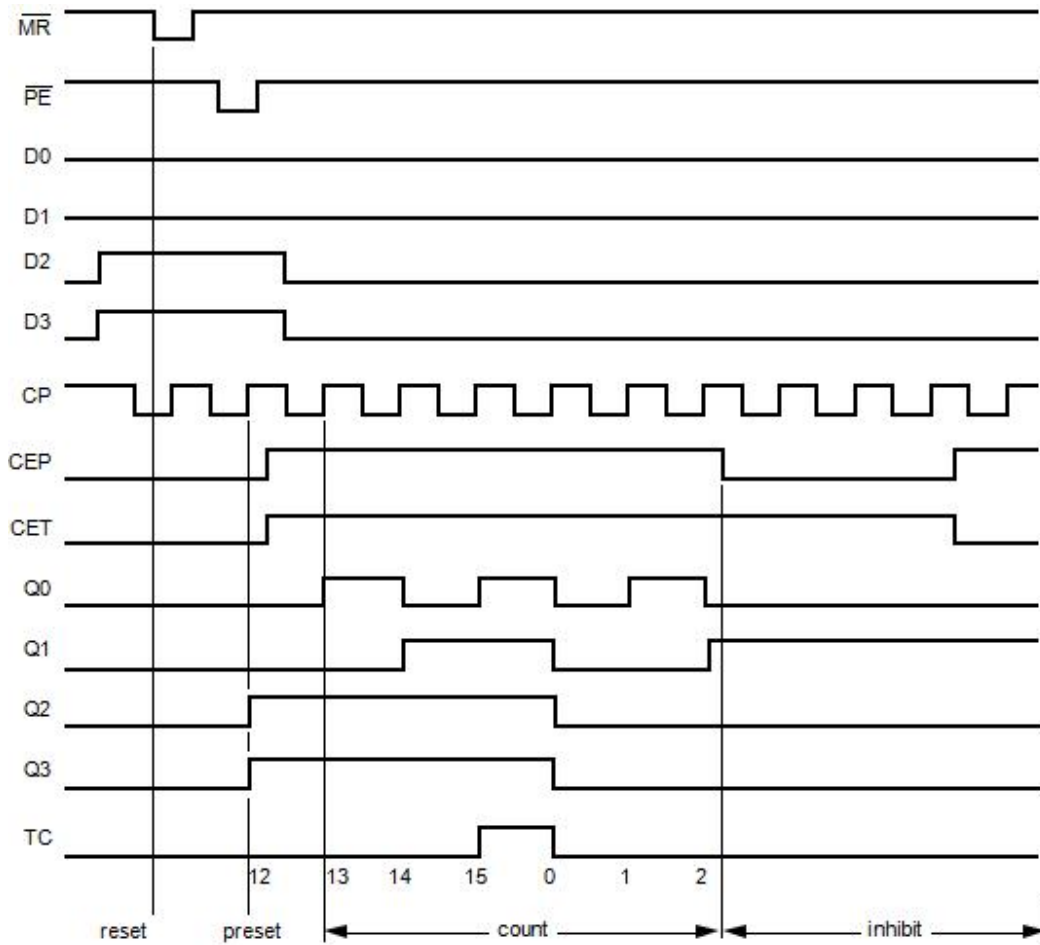

Typical timing sequence: reset outputs to zero; preset to binary twelve; count to thirteen, fourteen, fifteen, zero, one and two; inhibit.

**Fig. 8. Typical timing sequence**

## Limiting values

In accordance with the Absolute Maximum Rating System (IEC 60134). Voltages are referenced to GND (ground = 0 V).

Symbol	Parameter	Conditions	Min	Max	Unit
$V_{CC}$	supply voltage		-0.5	+7.0	V
$I_{IK}$	input clamping current	$V_I < -0.5\text{ V}$ or $V_I > V_{CC} + 0.5\text{ V}$	-	$\pm 20$	mA
$I_{OK}$	output clamping current	$V_O < -0.5\text{ V}$ or $V_O > V_{CC} + 0.5\text{ V}$	-	$\pm 20$	mA
$I_O$	output current	$V_O = -0.5\text{ V}$ to $V_{CC} + 0.5\text{ V}$	-	$\pm 25$	mA
$I_{CC}$	supply current		-	50	mA
$I_{GND}$	ground current		-50	-	mA
$T_{stg}$	storage temperature		-65	+150	°C
$T_L$	Soldering temperature		-	+245	°C
$P_{tot}$	total power dissipation	[1]	-	500	mW

Absolute Maximum Ratings indicate limits beyond which damage to the device may occur. Operating Ratings indicate conditions for which the device is intended to be functional, but specific performance is not ensured.

For SO16 packages: above 70 °C the value of  $P_{tot}$  derates linearly at 8mW/K.

For (T)SSOP16 packages: above 60 °C the value of  $P_{tot}$  derates linearly at 5.5mW/K.

## Recommended operating conditions

Voltages are referenced to GND (ground = 0 V)

Symbol	Parameter	Conditions	Min	Typ	Max	Unit
V <sub>CC</sub>	supply voltage		2.0	5.0	6.0	V
V <sub>I</sub>	input voltage		0	-	V <sub>CC</sub>	V
V <sub>O</sub>	output voltage		0	-	V <sub>CC</sub>	V
T <sub>amb</sub>	ambient temperature		-40	+25	+85	°C
Δt/ΔV	input transition rise and fall rate	V <sub>CC</sub> = 2.0 V	-	-	625	ns/V
		V <sub>CC</sub> = 4.5 V	-	1.67	139	ns/V
		V <sub>CC</sub> = 6.0 V	-	-	83	ns/V

## Static characteristics

At recommended operating conditions; voltages are referenced to GND (ground = 0 V).

Symbol	Parameter	Conditions	25 °C			-40 °C to +85 °C		Unit
			Min	Typ	Max	Min	Max	
V <sub>IH</sub>	HIGH-level input voltage	V <sub>CC</sub> = 2.0 V	1.5	1.2	-	1.5	-	V
		V <sub>CC</sub> = 4.5 V	3.15	2.4	-	3.15	-	V
		V <sub>CC</sub> = 6.0 V	4.2	3.2	-	4.2	-	V
V <sub>IL</sub>	LOW-level input voltage	V <sub>CC</sub> = 2.0 V	-	0.8	0.5	-	0.5	V
		V <sub>CC</sub> = 4.5 V	-	2.1	1.35	-	1.35	V
		V <sub>CC</sub> = 6.0 V	-	2.8	1.8	-	1.8	V
V <sub>OH</sub>	HIGH-level output voltage	V <sub>I</sub> = V <sub>IH</sub> or V <sub>IL</sub>						
		I <sub>O</sub> = -20 μA; V <sub>CC</sub> = 2.0 V	1.9	2.0	-	1.9	-	V
		I <sub>O</sub> = -20 μA; V <sub>CC</sub> = 4.5 V	4.4	4.5	-	4.4	-	V
		I <sub>O</sub> = -20 μA; V <sub>CC</sub> = 6.0 V	5.9	6.0	-	5.9	-	V
		I <sub>O</sub> = -4.0 mA; V <sub>CC</sub> = 4.5 V	3.98	4.32	-	3.84	-	V
I <sub>O</sub> = -5.2 mA; V <sub>CC</sub> = 6.0 V	5.48	5.81	-	5.34	-	V		
V <sub>OL</sub>	LOW-level output voltage	V <sub>I</sub> = V <sub>IH</sub> or V <sub>IL</sub>						
		I <sub>O</sub> = 20 μA; V <sub>CC</sub> = 2.0 V	-	0	0.1	-	0.1	V
		I <sub>O</sub> = 20 μA; V <sub>CC</sub> = 4.5 V	-	0	0.1	-	0.1	V
		I <sub>O</sub> = 20 μA; V <sub>CC</sub> = 6.0 V	-	0	0.1	-	0.1	V
		I <sub>O</sub> = 4.0 mA; V <sub>CC</sub> = 4.5 V	-	0.15	0.26	-	0.33	V
I <sub>O</sub> = 5.2 mA; V <sub>CC</sub> = 6.0 V	-	0.16	0.26	-	0.33	V		
I <sub>I</sub>	input leakage current	V <sub>I</sub> = V <sub>CC</sub> or GND; V <sub>CC</sub> = 6.0 V	-	-	±0.1	-	±1.0	μA
I <sub>CC</sub>	supply current	V <sub>I</sub> = V <sub>CC</sub> or GND; I <sub>O</sub> = 0 A; V <sub>CC</sub> = 6.0 V	-	-	8.0	-	80.0	μA
C <sub>I</sub>	input capacitance		-	3.5	-	-	-	pF

## Dynamic characteristics

Voltages are referenced to GND (ground = 0 V);  $C_L = 50$  pF unless otherwise specified; for test circuit see Fig. 14.

Symbol	Parameter	Conditions	25 °C			-40 °C to +85 °C		Unit
			Min	Typ	Max	Min	Max	
$t_{pd}$	propagation delay	CP to Qn; see Fig. 9[1]						
		$V_{CC} = 2.0$ V	-	61	190	-	240	ns
		$V_{CC} = 4.5$ V	-	22	38	-	48	ns
		$V_{CC} = 5.0$ V; $C_L = 15$ pF	-	19	-	-	-	ns
		$V_{CC} = 6.0$ V	-	18	32	-	41	ns
		CP to TC; see Fig. 9						
		$V_{CC} = 2.0$ V	-	69	215	-	270	ns
		$V_{CC} = 4.5$ V	-	25	43	-	54	ns
		$V_{CC} = 5.0$ V; $C_L = 15$ pF	-	21	-	-	-	ns
		$V_{CC} = 6.0$ V	-	20	37	-	46	ns
		CET to TC; see Fig. 10						
		$V_{CC} = 2.0$ V	-	33	150	-	190	ns
		$V_{CC} = 4.5$ V	-	12	30	-	38	ns
		$V_{CC} = 5.0$ V; $C_L = 15$ pF	-	10	-	-	-	ns
$V_{CC} = 6.0$ V	-	10	26	-	38	ns		
$t_{PHL}$	HIGH to LOW propagation delay	$\overline{MR}$ to Qn; see Fig. 11						
		$V_{CC} = 2.0$ V	-	63	210	-	265	ns
		$V_{CC} = 4.5$ V	-	23	42	-	53	ns
		$V_{CC} = 5.0$ V; $C_L = 15$ pF	-	20	-	-	-	ns
		$V_{CC} = 6.0$ V	-	18	36	-	45	ns
		$\overline{MR}$ to TC; see Fig. 11						
		$V_{CC} = 2.0$ V	-	63	220	-	275	ns
		$V_{CC} = 4.5$ V	-	23	44	-	55	ns
		$V_{CC} = 5.0$ V; $C_L = 15$ pF	-	20	-	-	-	ns
$V_{CC} = 6.0$ V	-	18	37	-	47	ns		
$t_t$	transition time	see Fig. 9 and Fig. 10 [2]						
		$V_{CC} = 2.0$ V	-	19	75	-	95	ns
		$V_{CC} = 4.5$ V	-	7	15	-	19	ns
		$V_{CC} = 6.0$ V	-	6	13	-	16	ns
$t_w$	pulse width	CP; HIGH or LOW; see Fig. 9						
		$V_{CC} = 2.0$ V	80	22	-	100	-	ns
		$V_{CC} = 4.5$ V	16	8	-	20	-	ns
		$V_{CC} = 6.0$ V	14	6	-	17	-	ns
		$\overline{MR}$ ; LOW; see Fig. 11						
		$V_{CC} = 2.0$ V	80	19	-	100	-	ns
		$V_{CC} = 4.5$ V	16	7	-	20	-	ns
$V_{CC} = 6.0$ V	14	6	-	17	-	ns		



Symbol	Parameter	Conditions	25 °C			-40 °C to +85 °C		Unit
			Min	Typ	Max	Min	Max	
trec	recovery time	MR to CP; see Fig. 11						
		V <sub>CC</sub> = 2.0 V	100	19	-	125	-	ns
		V <sub>CC</sub> = 4.5 V	20	7	-	25	-	ns
		V <sub>CC</sub> = 6.0 V	17	6	-	21	-	ns
tsu	set-up time	Dn to CP; see Fig. 12						
		V <sub>CC</sub> = 2.0 V	80	25	-	100	-	ns
		V <sub>CC</sub> = 4.5 V	16	9	-	20	-	ns
		V <sub>CC</sub> = 6.0 V	14	7	-	17	-	ns
		PE to CP; see Fig. 12						
		V <sub>CC</sub> = 2.0 V	100	30	-	125	-	ns
		V <sub>CC</sub> = 4.5 V	20	11	-	25	-	ns
		V <sub>CC</sub> = 6.0 V	17	9	-	21	-	ns
		CEP, CET to CP; see Fig. 13						
		V <sub>CC</sub> = 2.0 V	170	47	-	215	-	ns
		V <sub>CC</sub> = 4.5 V	34	17	-	43	-	ns
		V <sub>CC</sub> = 6.0 V	29	14	-	37	-	ns
th	hold time	Dn, PE, CEP, CET to CP; see Fig. 12 and Fig. 13						
		V <sub>CC</sub> = 2.0 V	0	-14	-	0	-	ns
		V <sub>CC</sub> = 4.5 V	0	-5	-	0	-	ns
		V <sub>CC</sub> = 6.0 V	0	-4	-	0	-	ns
fmax	maximum frequency	CP; see Fig. 9						
		V <sub>CC</sub> = 2.0 V	4.6	13	-	3.6	-	MHz
		V <sub>CC</sub> = 4.5 V	23	40	-	18	-	MHz
		V <sub>CC</sub> = 5.0 V; CL = 15 pF	-	44	-	-	-	MHz
		V <sub>CC</sub> = 6.0 V	27	48	-	21	-	MHz
CPD	power dissipation capacitance	V <sub>I</sub> = GND to V <sub>CC</sub> ; V <sub>CC</sub> = 5 V; [3] fi = 1 MHz	-	33	-	-	-	pF

1. t<sub>pd</sub> is the same as t<sub>PHL</sub> and t<sub>PLH</sub>.
2. tt is the same as t<sub>THL</sub> and t<sub>TLH</sub>.
3. C<sub>PD</sub> is used to determine the dynamic power dissipation (P<sub>D</sub> in μW):
4. P<sub>D</sub> = C<sub>PD</sub> × V<sub>CC</sub><sup>2</sup> × fi × N + ∑(C<sub>L</sub> × V<sub>CC</sub><sup>2</sup> × fo) where:
5. fi = input frequency in MHz;
6. fo = output frequency in MHz;
7. C<sub>L</sub> = output load capacitance in pF;
8. V<sub>CC</sub> = supply voltage in V;
9. N = number of inputs switching;
10. ∑(C<sub>L</sub> × V<sub>CC</sub><sup>2</sup> × fo) = sum of outputs.

## Switching Waveforms

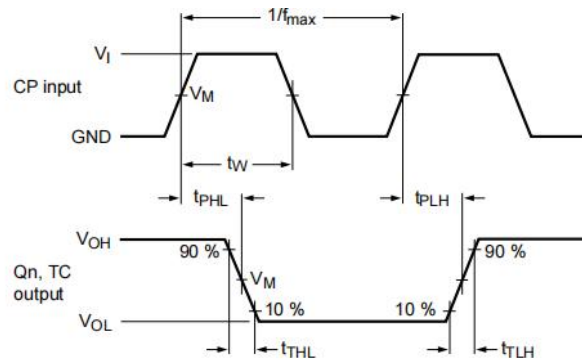

Measurement points are given in **Table 8**.

Logic levels  $V_{OL}$  and  $V_{OH}$  are typical output voltage levels that occur with the output load.

**Fig. 9. The clock (CP) to outputs (Qn, TC) propagation delays, pulse width, output transition times and maximum frequency**

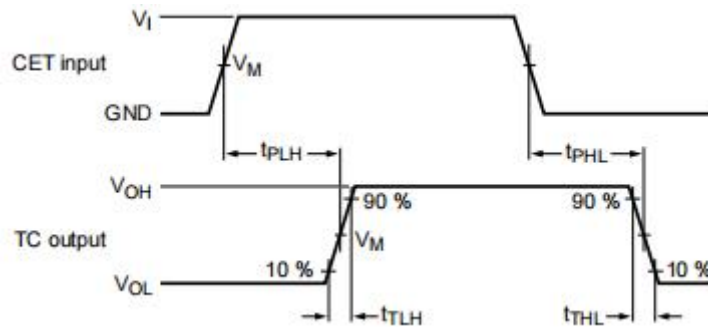

Measurement points are given in Table 8.

Logic levels  $V_{OL}$  and  $V_{OH}$  are typical output voltage levels that occur with the output load.

**Fig. 10. The count enable carry input (CET) to terminal count output (TC) propagation delays and output transition times**

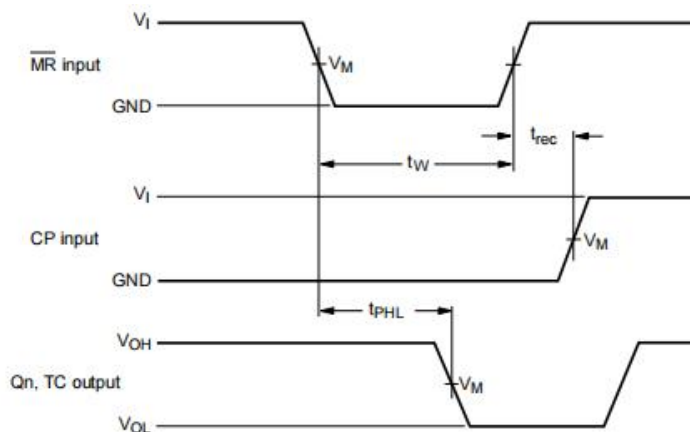

Measurement points are given in Table 8.

Logic levels  $V_{OL}$  and  $V_{OH}$  are typical output voltage levels that occur with the output load.

**Fig. 11. The master reset (MR) pulse width, master reset to output (Qn, TC) propagation delays, and the master reset to clock (CP) recovery times**

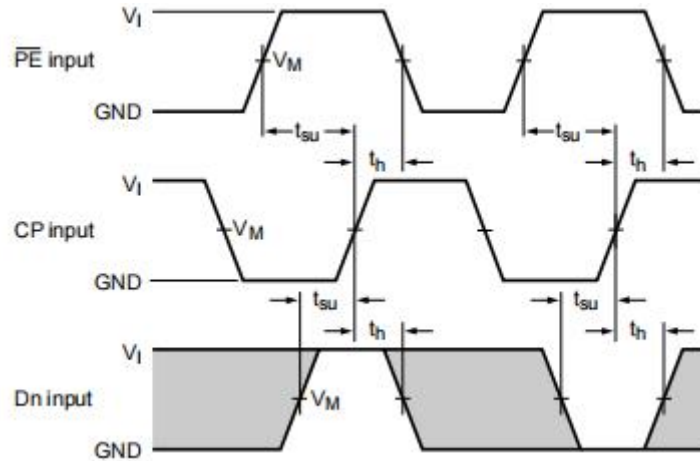

Measurement points are given in Table 8.

The shaded areas indicate when the input is permitted to change for predictable output performance.

**Fig. 12. The data input (Dn) and parallel enable input ( $\overline{PE}$ ) set-up and hold times**

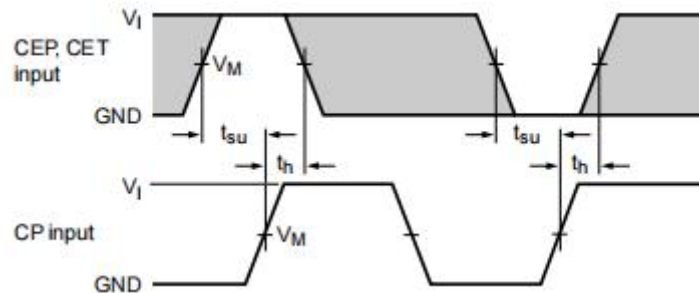

Measurement points are given in Table 8.

The shaded areas indicate when the input is permitted to change for predictable output performance.

**Fig. 13. The count enable input (CEP) and count enable carry input (CET) set-up and hold times**

### Measurement points

Input		Output
VM	VI	VM
$0.5 \times V_{CC}$	GND to $V_{CC}$	$0.5 \times V_{CC}$

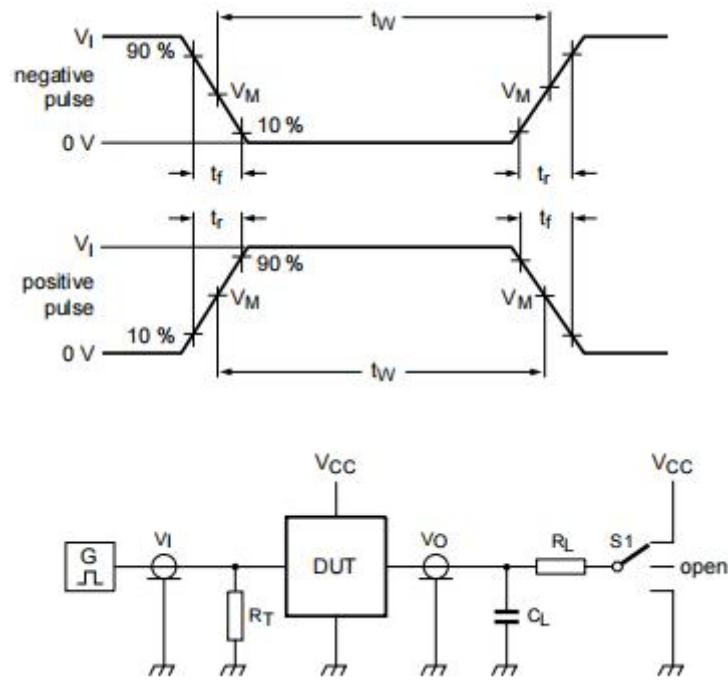

Test data is given in Table 9.

Test circuit definitions:

$R_T$  = Termination resistance should be equal to output impedance  $Z_o$  of the pulse generator

$C_L$  = Load capacitance including jig and probe capacitance

$R_L$  = Load resistance.

S1 = Test selection switch

**Fig. 14. Test circuit for measuring switching times**

#### Test data

Input		Load		S1 position
$V_i$	$t_r, t_f$	$C_L$	$R_L$	$t_{PHL}, t_{PLH}$
$V_{CC}$	6 ns	15 pF, 50 pF	1 k $\Omega$	open

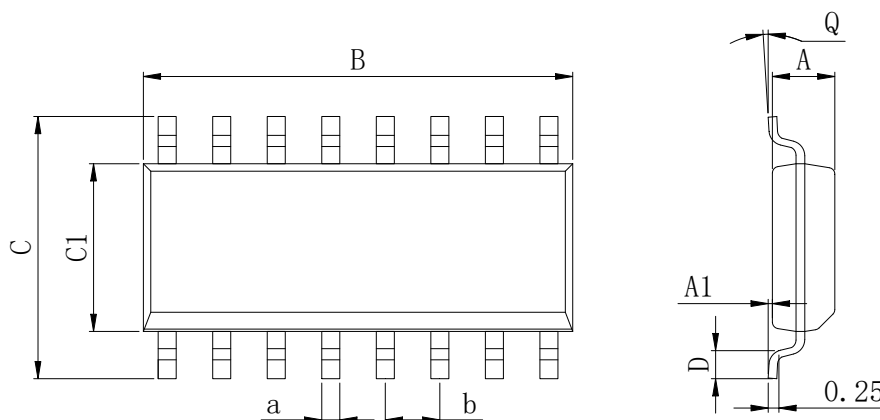
**Physical Dimensions**
**SOP-16**

**Dimensions In Millimeters(SOP-16)**

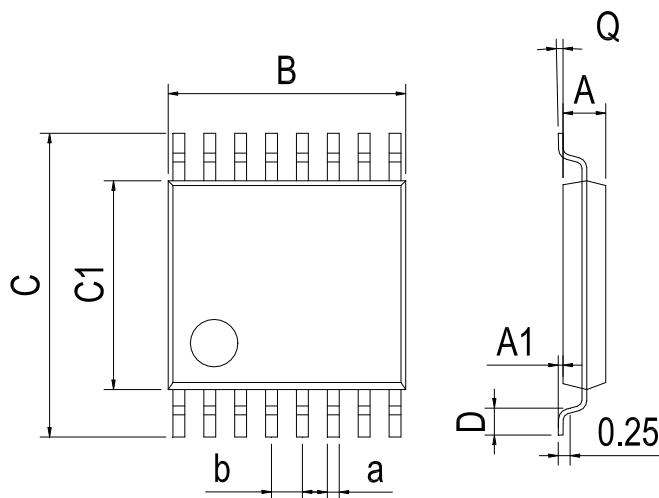
Symbol:	A	A1	B	C	C1	D	Q	a	b
Min:	1.35	0.05	9.80	5.80	3.80	0.40	0°	0.35	1.27 BSC
Max:	1.55	0.20	10.0	6.20	4.00	0.80	8°	0.45	

**TSSOP-16**

**Dimensions In Millimeters(TSSOP-16)**

Symbol:	A	A1	B	C	C1	D	Q	a	b
Min:	0.85	0.05	4.90	6.20	4.30	0.40	0°	0.20	0.65 BSC
Max:	0.95	0.20	5.10	6.60	4.50	0.80	8°	0.25	

## Physical Dimensions

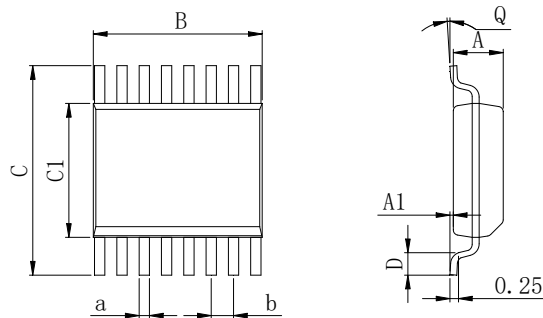
QSOP-16



Dimensions In Millimeters(QSOP-16)									
Symbol:	A	A1	B	C	C1	D	Q	a	b
Min:	1.35	0.05	4.80	5.80	3.80	0.40	0°	0.20	0.635 BSC
Max:	1.55	0.20	5.10	6.20	4.00	0.80	8°	0.25	

## Revision History

DATE	REVISION	PAGE
2014-6-8	New	1-16
2023-9-8	Modify the package dimension diagram TSSOP-16、 Update encapsulation type、 Update Soldering temperature、 Add annotation for Maximum Ratings.	13、 1、 6

**IMPORTANT STATEMENT:**

Hanschip Semiconductor reserves the right to change its products and services without notice. Before ordering, the customer shall obtain the latest relevant information and verify whether the information is up to date and complete. Hanschip Semiconductor does not assume any responsibility or obligation for the altered documents.

Customers are responsible for complying with safety standards and taking safety measures when using Hanschip Semiconductor products for system design and machine manufacturing. You will bear all the following responsibilities: select the appropriate Hanschip Semiconductor products for your application; Design, validate and test your application; Ensure that your application meets the appropriate standards and any other safety, security or other requirements. To avoid the occurrence of potential risks that may lead to personal injury or property loss.

Hanschip Semiconductor products have not been approved for applications in life support, military, aerospace and other fields, and Hanschip Semiconductor will not bear the consequences caused by the application of products in these fields. All problems, responsibilities and losses arising from the user's use beyond the applicable area of the product shall be borne by the user and have nothing to do with Hanschip Semiconductor, and the user shall not claim any compensation liability against Hanschip Semiconductor by the terms of this Agreement.

The technical and reliability data (including data sheets), design resources (including reference designs), application or other design suggestions, network tools, safety information and other resources provided for the performance of semiconductor products produced by Hanschip Semiconductor are not guaranteed to be free from defects and no warranty, express or implied, is made. The use of testing and other quality control technologies is limited to the quality assurance scope of Hanschip Semiconductor. Not all parameters of each device need to be tested.

The documentation of Hanschip Semiconductor authorizes you to use these resources only for developing the application of the product described in this document. You have no right to use any other Hanschip Semiconductor intellectual property rights or any third party intellectual property rights. It is strictly forbidden to make other copies or displays of these resources. You should fully compensate Hanschip Semiconductor and its agents for any claims, damages, costs, losses and debts caused by the use of these resources. Hanschip Semiconductor accepts no liability for any loss or damage caused by infringement.



单击下面可查看定价，库存，交付和生命周期等信息

[>>HGC\(深圳汉芯\)](#)