

UNIVERSAL HIGH BRIGHTNESS LED DRIVER

Features

- >90% Efficiency
- 8V to 450V input range
- Constant-current LED driver
- Applications from a few mA to more than 1A output
- LED string from one to hundreds of diodes
- PWM Low-Frequency Dimming via Enable pin

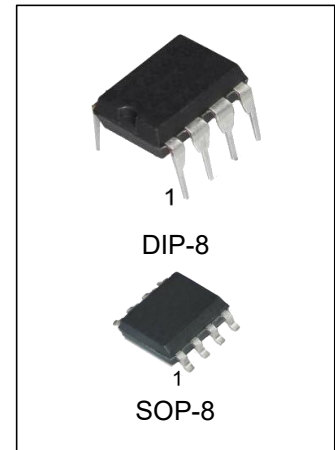

Ordering Information

DEVICE	Package Type	MARKING	Packing	Packing Qty
HX9910PG	DIP-8	HX9910	REEL	2000pcs/reel
HX9910DRG	SOP-8	HX9910	REEL	2500pcs/reel

Description

The HX9910 is a PWM high-efficiency LED driver control IC. It allows efficient operation of High Brightness (HB) LEDs from voltage sources ranging from 8VDC up to 450VDC. The HX9910 controls an external MOSFET at fixed switching frequency up to 300kHz. The frequency can be programmed using a single resistor. The LED string is driven at constant current rather than constant voltage, thus providing constant light output and enhanced reliability. The output current can be programmed between a few milliamps and up to more than 1.0A.

HX9910 uses a rugged high voltage junction isolated process that can withstand an input voltage surge of up to 450V. Output current to an LED string can be programmed to any value between zero and its maximum value by applying an external control voltage at the linear dimming control input of the HX9910. The HX9910 provides a low-frequency PWM dimming input that can accept an external control signal with a duty ratio of 0-100% and a frequency of up to a few kilohertz.

Applications

- DC/DC or AC/DC LED Driver applications
- RGB Backlighting LED Driver
- Back Lighting of Flat Panel Displays
- General purpose constant current source
- Signage and Decorative LED Lighting
- Automotive

Functional Block Diagram

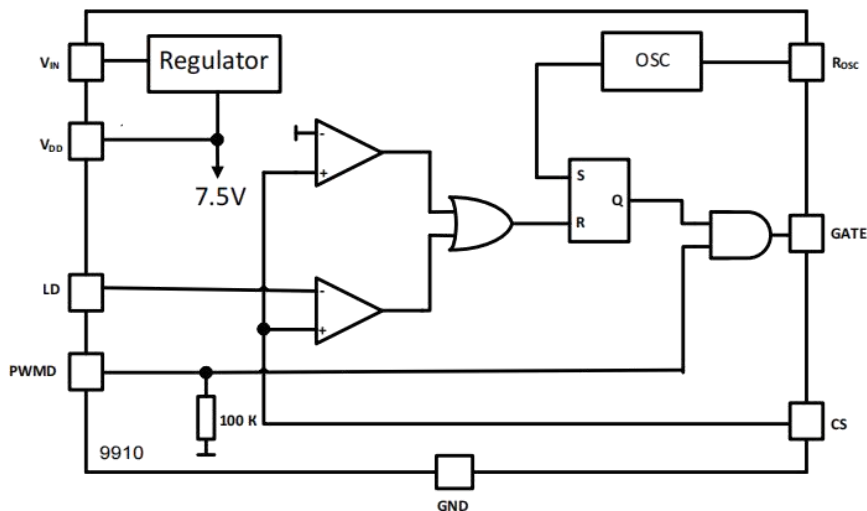

Pin Configuration

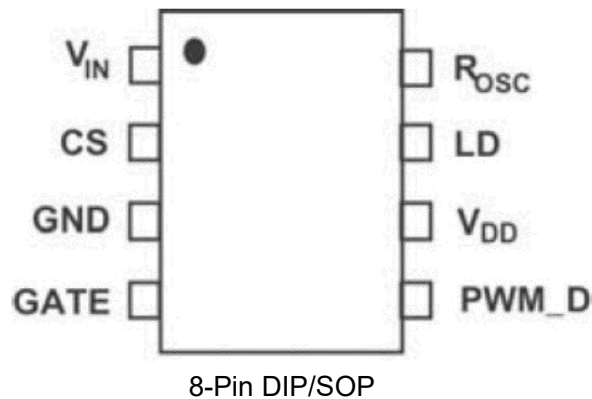

Pin Description

Pin #	Name	Description
1	VIN	Input voltage 8V to 450V DC
2	CS	Senses LED string current
3	GND	Device ground
4	GATE	Drives the gate of the external MOSFET
5	PWMD	Low Frequency PWM Dimming pin, also Enable input. Internal 100kΩ pull-down to GND
6	VDD	Internally regulated supply voltage. 7.5V nominal. Can supply up to 1mA for external circuitry. A sufficient storage capacitor is used to provide storage when the rectified AC input is near the zero crossings.
7	LD	Linear Dimming by changing the current limit threshold at current sense comparator
8	Rosc	Oscillator control. A resistor connected between this pin and ground sets the PWM frequency.

Electrical Characteristics

Absolute Maximum Ratings

Parameter	Rating	Unit
VIN to GND	-0.5 to +470	V
CS	-0.3V to +15.8	V
LD, PWMD to GND	-0.3V to +15.1	V
GATE to GND	-0.3V to +15.8	V
VDD MAX	13.5	V
ESD Capability, all pads except Pad 1 (VIN) and Pad 7,8 (VDD)	2.0	kV
Maximum Voltage on Pad 1 (VIN) and Pad 7,8 (VDD)	470	V
Operating Temperature Range	-40 to +85	°C
Junction Temperature	+125	°C
Lead Temperature (TL) (Soldering, 10 seconds)	+245	°C
Storage Temperature Range	-65 to +150	°C
Power Dissipation @+25 °C for DIP-8	900	mW
Power Dissipation @+25 °C for SOP-8	630	mW

Note: Stresses above those listed under “Absolute Maximum Ratings” may cause permanent damage to the device. This is a stress rating only and functional operation of the device at those or any other conditions, above those indicated in the operational listings of this specification, is not implied. Exposure to maximum rating conditions for extended periods may affect device reliability.

Electrical Characteristics¹

Symbol	Description	Min	Typ	Max	Unit	Conditions
VINDC	Input DC supply voltage range	8.0		450	V	DC input voltage
IINsd	Shut-Down mode supply current		0.5	1	mA	Pin PWM_D to GND, VIN= 8V
VDD	Internally regulated voltage	7.0	7.5	8.0	V	VIN = 8-450V, IDD(ext)=0, pin Gate open
VDDmax	Maximal pin VDD voltage			13.5	V	When an external voltage applied to pinVDD
IDD(ext)	VDD current available for external circuitry ¹			1.0	mA	VIN = 8-100V
UVLO	VDD undervoltage lockout threshold	6.45	6.7	6.95	V	VIN rising
ΔUVLO	VDD undervoltage lockout hysteresis		500		mV	VIN falling
VEN(lo)	Pin PWM_D input low voltage			1.0	V	VIN = 8-450V
VEN(hi)	Pin PWM_D input high voltage	2.4			V	VIN = 8-450V
REN	Pin PWM_D pull-down resistance	50	100	150	κOhm	VEN = 5V
VCS(hi)	Current sense pull-in threshold voltage	225	250	275	mV	@TA = -40°C ÷ +85°C
VGATE(hi)	GATE high output voltage	VDD -0.3		VDD	V	IOUT= 10 mA
vGATE(lo)	GATE low output voltage	0		0.3	V	IOUT = -10 mA
fOSC	Oscillator frequency	20 80	25 100	30 120	κHz κHZ	Rosc = 1.00 MOhmRosc = 226 κOhm
DMAXhf	Maximum Oscillator PWM Duty Cycle			100	%	FPWMhf = 25kHz, at GATE, CS to GND
VLD	Linear Dimming pin voltage range	0		250	mV	@TA = <85°C, Vin = 12 V
TBLANK	Current sense blanking interval	150	215	280	ns	VCS = 0.55VLD, VLD = VDD
tDELAY	Delay from CS trip to GATE lo			300	ns	Vin = 12 V, VLD = 0.15, Vcs = от 0 до0.22V после TBLANK
tRISE	GATE output rise time ²		30	50	ns	CGATE = 500 pF
tFALL	GATE output fall time ²		30	50	ns	CGATE = 500 pF

1. Also limited by package power dissipation limit, whichever is lower

Physical Dimensions

SOP-8

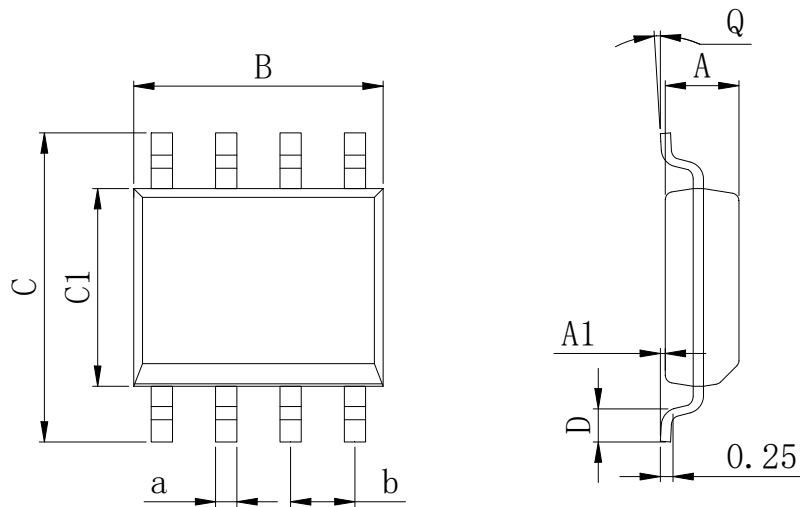

Dimensions In Millimeters(SOP-8)

Symbol:	A	A1	B	C	C1	D	Q	a	b
Min:	1.35	0.05	4.90	5.80	3.80	0.40	0°	0.35	1.27 BSC
Max:	1.55	0.20	5.10	6.20	4.00	0.80	8°	0.45	

DIP-8

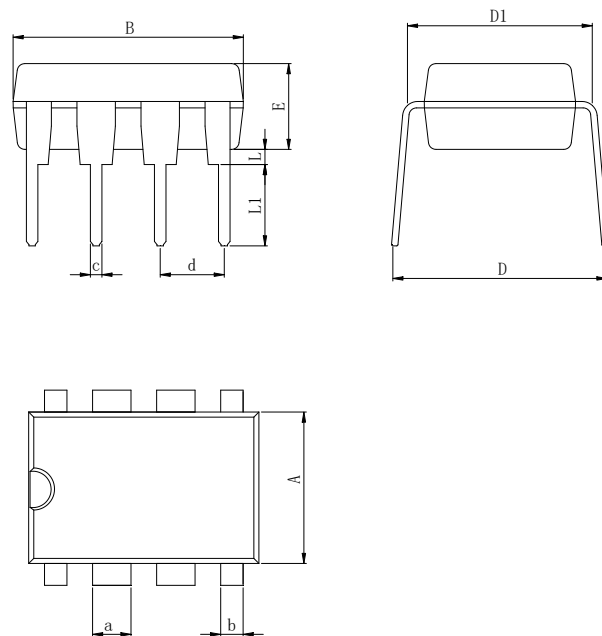

Dimensions In Millimeters(DIP-8)

Symbol:	A	B	D	D1	E	L	L1	a	b	c	d
Min:	6.10	9.00	8.10	7.42	3.10	0.50	3.00	1.50	0.85	0.40	2.54 BSC
Max:	6.68	9.50	10.9	7.82	3.55	0.70	3.60	1.55	0.90	0.50	

Revision History

DATE	REVISION	PAGE
2020-3-6	New	1-8
2023-8-30	Update encapsulation type、Update Lead Temperature、Updated DIP-8 dimension	1、 4、 6
2024-4-9	Delete MSOP-8 Ordering Information	1

IMPORTANT STATEMENT:

Hanschip Semiconductor reserves the right to change its products and services without notice. Before ordering, the customer shall obtain the latest relevant information and verify whether the information is up to date and complete. Hanschip Semiconductor does not assume any responsibility or obligation for the altered documents.

Customers are responsible for complying with safety standards and taking safety measures when using Hanschip Semiconductor products for system design and machine manufacturing. You will bear all the following responsibilities: select the appropriate Hanschip Semiconductor products for your application; Design, validate and test your application; Ensure that your application meets the appropriate standards and any other safety, security or other requirements. To avoid the occurrence of potential risks that may lead to personal injury or property loss.

Hanschip Semiconductor products have not been approved for applications in life support, military, aerospace and other fields, and Hanschip Semiconductor will not bear the consequences caused by the application of products in these fields. All problems, responsibilities and losses arising from the user's use beyond the applicable area of the product shall be borne by the user and have nothing to do with Hanschip Semiconductor, and the user shall not claim any compensation liability against Hanschip Semiconductor by the terms of this Agreement.

The technical and reliability data (including data sheets), design resources (including reference designs), application or other design suggestions, network tools, safety information and other resources provided for the performance of semiconductor products produced by Hanschip Semiconductor are not guaranteed to be free from defects and no warranty, express or implied, is made. The use of testing and other quality control technologies is limited to the quality assurance scope of Hanschip Semiconductor. Not all parameters of each device need to be tested.

The documentation of Hanschip Semiconductor authorizes you to use these resources only for developing the application of the product described in this document. You have no right to use any other Hanschip Semiconductor intellectual property rights or any third party intellectual property rights. It is strictly forbidden to make other copies or displays of these resources. You should fully compensate Hanschip Semiconductor and its agents for any claims, damages, costs, losses and debts caused by the use of these resources. Hanschip Semiconductor accepts no liability for any loss or damage caused by infringement.

单击下面可查看定价，库存，交付和生命周期等信息

[>>HGC\(深圳汉芯\)](#)