

1MHZ CMOS Rail-to-Rail IO Opamp with RF Filter

Features

- Single-Supply Operation from +2.1V ~ +5.5V
- Rail-to-Rail Input / Output
- Gain-Bandwidth Product: 1MHz (Typ.)
- Low Input Bias Current: 1pA (Typ.)
- Low Offset Voltage: 3.5mV (Max.)
- Quiescent Current: 40µA per Amplifier (Typ.)
- Operating Temperature: -40°C ~ +125°C
- Embedded RF Anti-EMI Filter

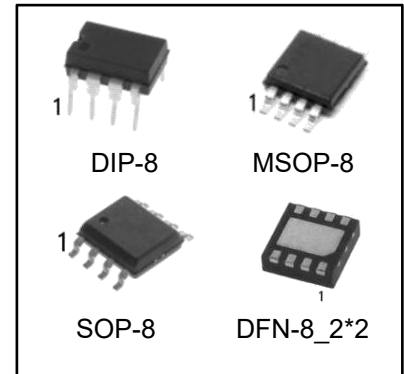

Ordering Information

DEVICE	Package Type	MARKING	Packing	Packing Qty
LMV602PG	DIP-8	LMV602	TUBE	2000pcs/Box
LMV602DRG	SOP-8	LMV602	REEL	2500pcs/Reel
LMV602DGKRG	MSOP-8	LMV602,V602	REEL	3000pcs/Reel
LMV602DQRG	DFN-8_2*2	LMV602	REEL	2500pcs/Reel

General Description

The LMV602 have a high gain-bandwidth product of 1MHz, a slew rate of 0.6V/µs, and a quiescent current of 40µA/amplifier at 5V. The LMV602 is designed to provide optimal performance in low voltage and low noise systems. They provide rail-to-rail output swing into heavy loads. The input common mode voltage range includes ground, and the maximum input offset voltage is 3.5mV for LMV602. They are specified over the extended industrial temperature range (-40°C to+125°C). The operating range is from 2.1V to 5.5V. The LMV602 Dual is available in Green SOP-8, MSOP8,DIP-8 and DFN-8 packages.

Applications

- ASIC Input or Output Amplifier
- Sensor Interface
- Medical Communication
- Smoke Detectors
- Audio Output
- Piezoelectric Transducer Amplifier
- Medical Instrumentation
- Portable Systems

Pin Configuration



Figure 1. LMV602 Pin Assignment Diagram

Absolute Maximum Ratings

Condition	Min	Max
Power Supply Voltage (V_{DD} to V_{SS})	-0.5V	+7.5V
Analog Input Voltage (IN+ or IN-)	$V_{SS}-0.5V$	$V_{DD}+0.5V$
PDB Input Voltage	$V_{SS}-0.5V$	+7V
Operating Temperature Range	-40°C	+125°C
Junction Temperature	+160°C	
Storage Temperature Range	-55°C	+150°C
Lead Temperature (soldering, 10sec)	+245°C	
Package Thermal Resistance ($T_A=+25^\circ\text{C}$)		
SOP-8, θ_{JA}	125°C/W	
MSOP-8, θ_{JA}	216°C/W	
ESD Susceptibility		
HBM	6KV	
MM	300V	

Note: Stress greater than those listed under Absolute Maximum Ratings may cause permanent damage to the device. This is a stress rating only and functional operation of the device at these or any other conditions outside those indicated in the operational sections of this specification are not implied. Exposure to absolute maximum rating conditions for extended periods may affect reliability.

Electrical Characteristics

(At $V_S = +5V$, $R_L = 100k\Omega$ connected to $V_S/2$, and $V_{OUT} = V_S/2$, unless otherwise noted.)

PARAMETER	SYMBOL	CONDITIONS	TYP	MIN/MAX OVER TEMPERATURE			
			+25°C	+25°C	-40°C to +85°C	UNITS	MIN/MAX
INPUT CHARACTERISTICS							
Input Offset Voltage	V_{OS}	$V_{CM} = V_S/2$	0.4	3.5	5.6	mV	MAX
Input Bias Current	I_B		1			pA	TYP
Input Offset Current	I_{OS}		1			pA	TYP
Common-Mode Voltage Range	V_{CM}	$V_S = 5.5V$	-0.1 to +5.6			V	TYP
Common-Mode Rejection Ratio	CMRR	$V_S=5.5V, V_{CM} = -0.1V$ to 4V	70	62	62	dB	MIN
		$V_S=5.5V, V_{CM}= -0.1V$ to 5.6V	68	56	55		
Open-Loop Voltage Gain	A_{OL}	$R_L=5k\Omega, V_O= +0.1V$ to +4.9V	80	70	70	dB	MIN
		$R_L=10k\Omega, V_O=+0.1V$ to +4.9V	100	90	85		
Input Offset Voltage Drift	$\Delta V_{OS}/\Delta T$		2.7			$\mu V/^\circ C$	TYP
OUTPUT CHARACTERISTICS							
Output Voltage Swing from Rail	V_{OH}	$R_L = 100k\Omega$	4.997	4.990	4.980	V	MIN
	V_{OL}	$R_L = 100k\Omega$	3	10	20	mV	MAX
	V_{OH}	$R_L = 10k\Omega$	4.992	4.970	4.960	V	MIN
	V_{OL}	$R_L = 10k\Omega$	8	30	40	mV	MAX
Output Current	I_{SOURCE}	$R_L = 10\Omega$ to $V_S/2$	84	60	45	mA	MIN
	I_{SINK}		75	60	45		
POWER SUPPLY							
Operating Voltage Range				2.1	2.5	V	MIN
				5.5	5.5	V	MAX
Power Supply Rejection Ratio	PSRR	$V_S = +2.5V$ to +5.5V, $V_{CM} = +0.5V$	82	60	58	dB	MIN
Quiescent Current / Amplifier	I_Q		40	60	80	μA	MAX
DYNAMIC PERFORMANCE (CL = 100pF)							
Gain-Bandwidth Product	GBP		1			MHz	TYP
Slew Rate	SR	$G = +1, 2V$ Output Step	0.6			V/ μs	TYP
Settling Time to 0.1%	t_s	$G = +1, 2V$ Output Step	5			μs	TYP
Overload Recovery Time		$V_{IN} \cdot Gain = V_S$	2.6			μs	TYP
NOISE PERFORMANCE							
Voltage Noise Density	e_n	$f = 1kHz$	27			nV/ \sqrt{Hz}	TYP
		$f = 10kHz$	20			nV/ \sqrt{Hz}	TYP

Typical Performance characteristics

At $T_A=+25^\circ\text{C}$, $V_S=+5\text{V}$, and $R_L=100\text{K}\Omega$ connected to $V_S/2$, unless otherwise noted.

Large-Signal Step Response

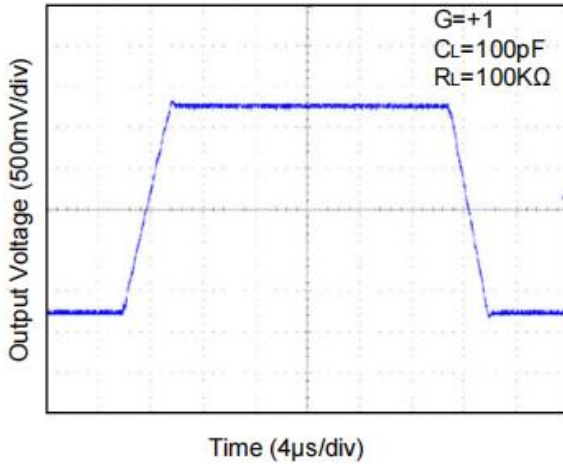

Small-Signal Step Response

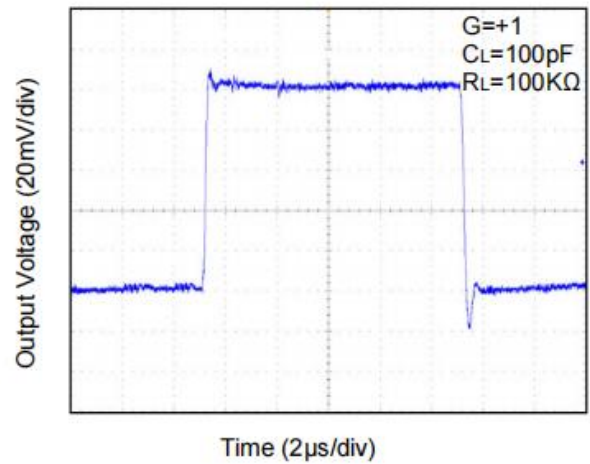

Supply Current vs. Supply Voltage

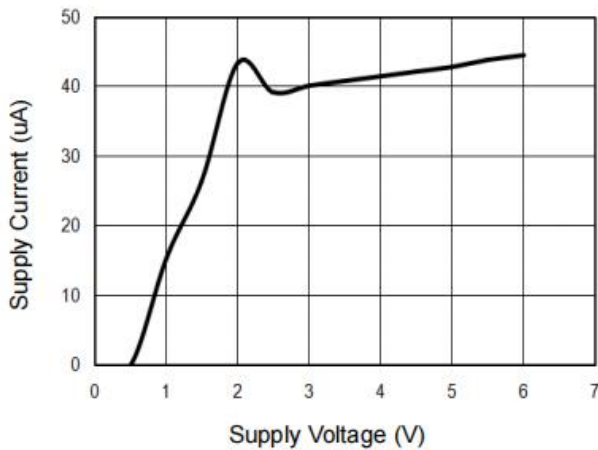

Short-Circuit Current vs. Supply Voltage

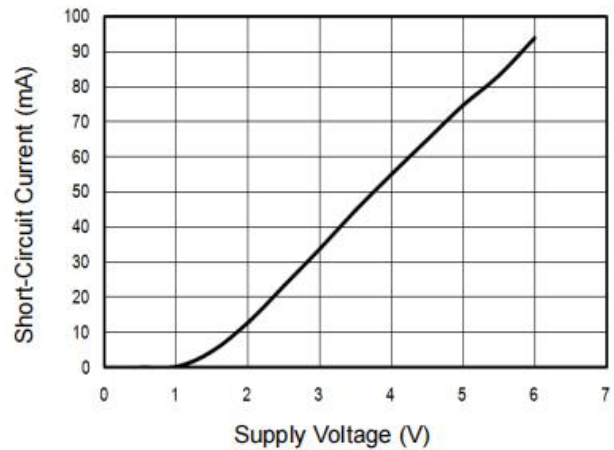

Output Voltage vs. Output Current

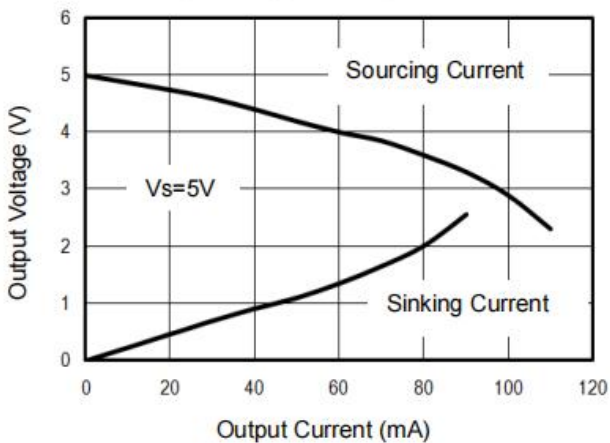

Output Voltage vs. Output Current

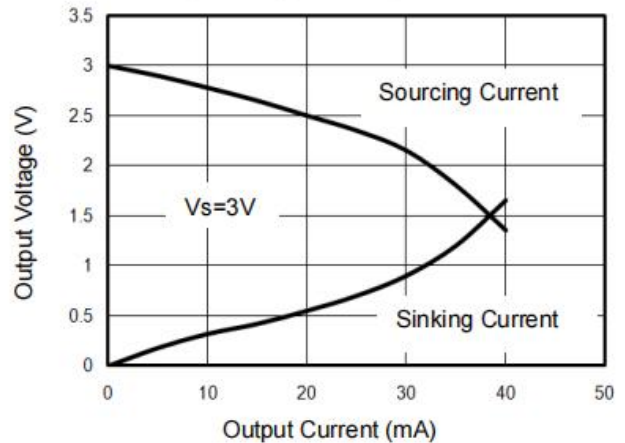

Typical Performance characteristics

At $T_A=+25^\circ\text{C}$, $V_S=+5\text{V}$, and $R_L=100\text{K}\Omega$ connected to $V_S/2$, unless otherwise noted.

Overload Recovery Time

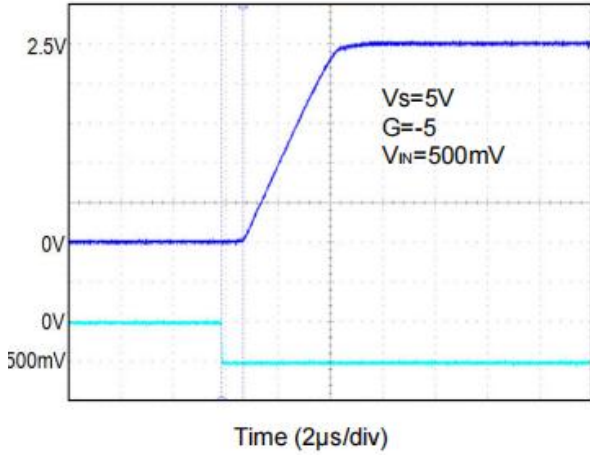

Supply Current vs. Temperature

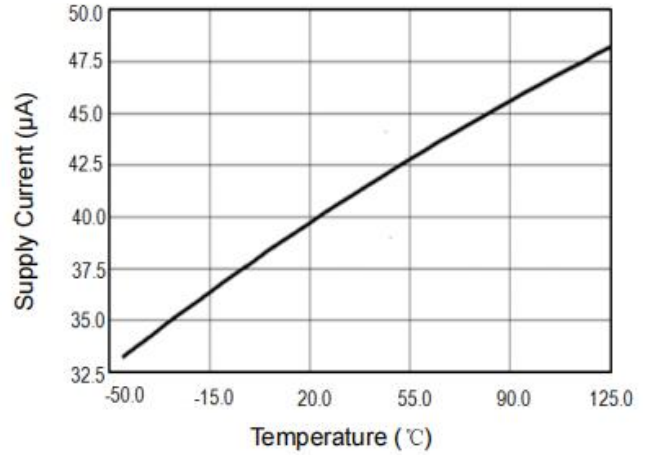

Input Voltage Noise Spectral Density vs. Frequency

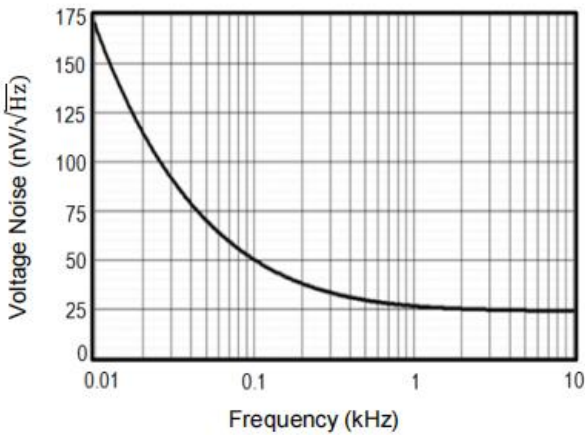

Open Loop Gain, Phase Shift vs. Frequency at +5V

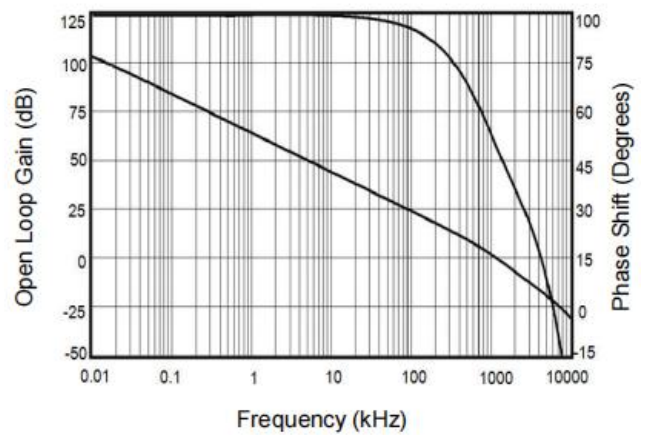

CMRR vs. Frequency

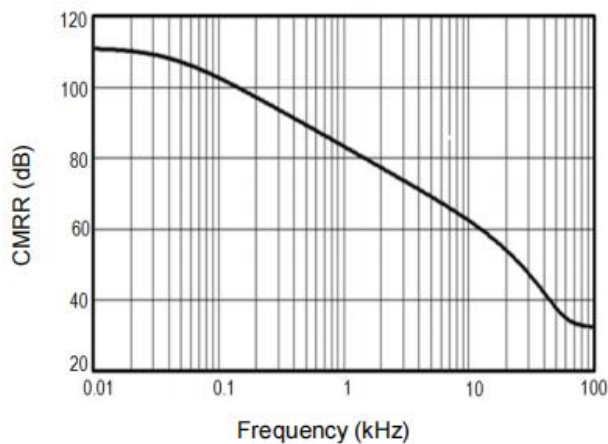

PSRR vs. Frequency

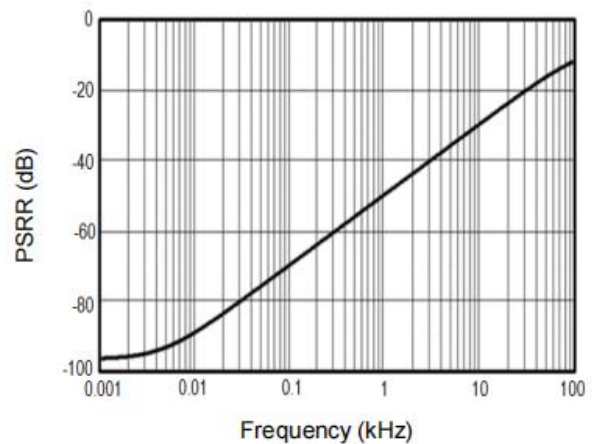

Application Note

Power Supply Bypassing and Board Layout

LMV602 series operates from a single 2.1V to 5.5V supply or dual $\pm 1.05\text{V}$ to $\pm 2.75\text{V}$ supplies. For best performance, a $0.1\mu\text{F}$ ceramic capacitor should be placed close to the VDD pin in single supply operation. For dual supply operation, both V_{DD} and V_{SS} supplies should be bypassed to ground with separate $0.1\mu\text{F}$ ceramic capacitors.

Low Supply Current

The low supply current (typical $40\mu\text{A}$ per channel) of LMV602 will help to maximize battery life. They are ideal for battery powered systems

Operating Voltage

LMV602 operates under wide input supply voltage (2.1V to 5.5V). In addition, all temperature specifications apply from -40°C to $+125^{\circ}\text{C}$. Most behavior remains unchanged throughout the full operating voltage range. These guarantees ensure operation throughout the single Li-Ion battery lifetime

Rail-to-Rail Input

The input common-mode range of LMV602 extends 100mV beyond the supply rails ($V_{SS}-0.1\text{V}$ to $V_{DD}+0.1\text{V}$). This is achieved by using complementary input stage. For normal operation, inputs should be limited to this range.

Rail-to-Rail Output

Rail-to-Rail output swing provides maximum possible dynamic range at the output. This is particularly important when operating in low supply voltages. The output voltage of LMV602 can typically swing to less than 5mV from supply rail in light resistive loads ($>100\text{k}\Omega$), and 30mV of supply rail in moderate resistive loads ($10\text{k}\Omega$).

Capacitive Load Tolerance

The LMV602 is optimized for bandwidth and speed, not for driving capacitive loads. Output capacitance will create a pole in the amplifier's feedback path, leading to excessive peaking and potential oscillation. If dealing with load capacitance is a requirement of the application, the two strategies to consider are (1) using a small resistor in series with the amplifier's output and the load capacitance and (2) reducing the bandwidth of the amplifier's feedback loop by increasing the overall noise gain. Figure 2. shows a unity gain follower using the series resistor strategy. The resistor isolates the output from the capacitance and, more importantly, creates a zero in the feedback path that compensates for the pole created by the output capacitance.

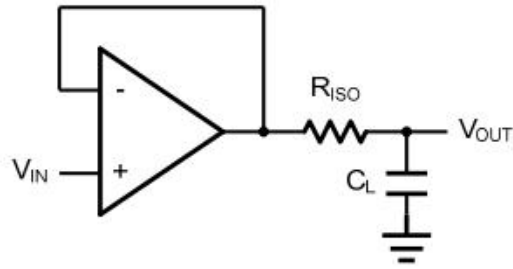

Figure 2. Indirectly Driving a Capacitive Load Using Isolation Resistor

The bigger the R_{ISO} resistor value, the more stable V_{OUT} will be. However, if there is a resistive load R_L in parallel with the capacitive load, a voltage divider (proportional to R_{ISO}/R_L) is formed, this will result in a gain error.

The circuit in Figure 3 is an improvement to the one in Figure 2. R_F provides the DC accuracy by feed-forward the V_{IN} to R_L . C_F and R_{ISO} serve to counteract the loss of phase margin by feeding the high frequency component of the output signal back to the amplifier's inverting input, thereby preserving the phase margin in the overall feedback loop. Capacitive drive can be increased by increasing the value of C_F . This in turn will slow down the pulse response.

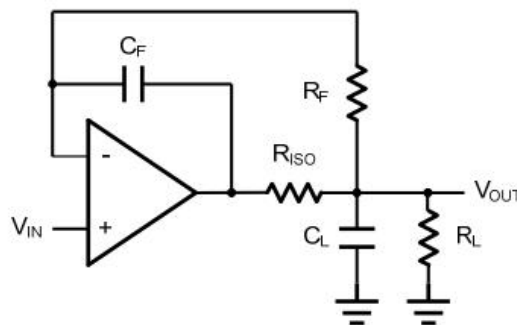
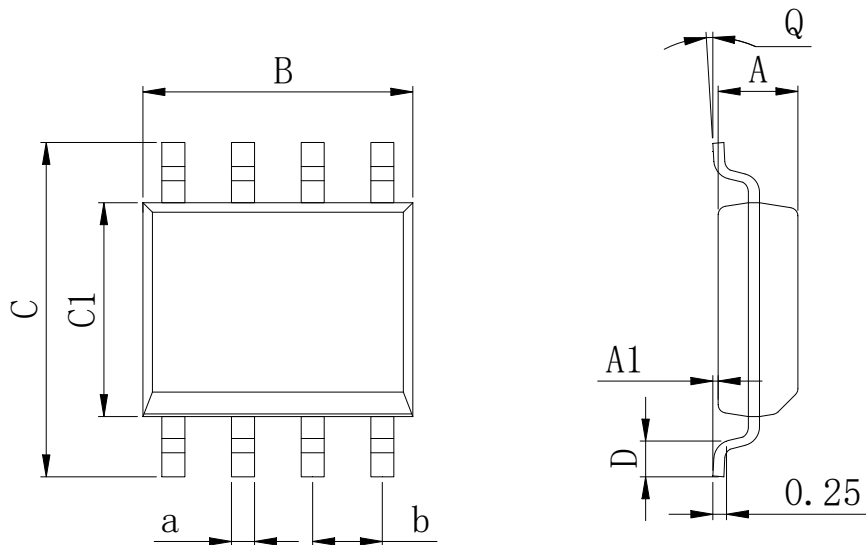
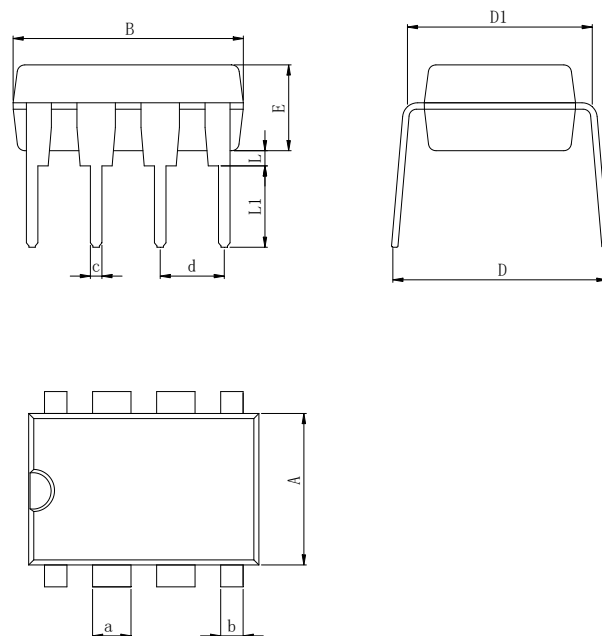

Figure 3. Indirectly Driving a Capacitive Load with DC Accuracy

Physical Dimensions
SOP-8

Dimensions In Millimeters(SOP-8)

Symbol:	A	A1	B	C	C1	D	Q	a	b
Min:	1.35	0.05	4.90	5.80	3.80	0.40	0°	0.35	1.27 BSC
Max:	1.55	0.20	5.10	6.20	4.00	0.80	8°	0.45	

DIP-8

Dimensions In Millimeters(DIP-8)

Symbol:	A	B	D	D1	E	L	L1	a	b	c	d
Min:	6.10	9.00	8.10	7.42	3.10	0.50	3.00	1.50	0.85	0.40	2.54 BSC
Max:	6.68	9.50	10.9	7.82	3.55	0.70	3.60	1.55	0.90	0.50	

Physical Dimensions

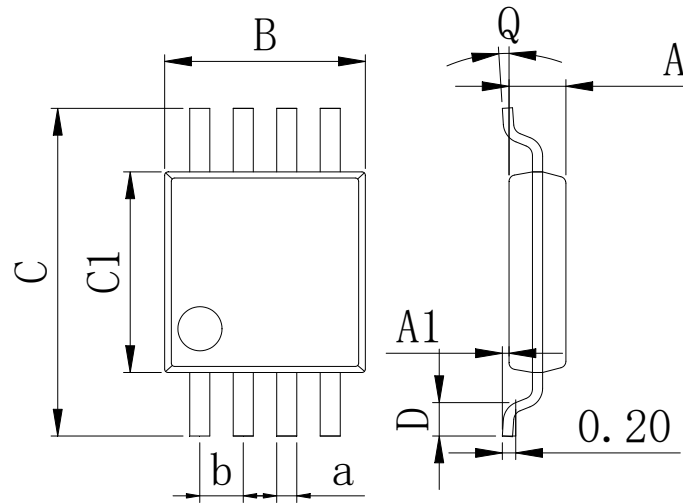
MSOP-8



Dimensions In Millimeters(MSOP-8)

Symbol:	A	A1	B	C	C1	D	Q	a	b
Min:	0.80	0.05	2.90	4.75	2.90	0.35	0°	0.25	0.65 BSC
Max:	0.90	0.20	3.10	5.05	3.10	0.75	8°	0.35	

DFN-8 2*2

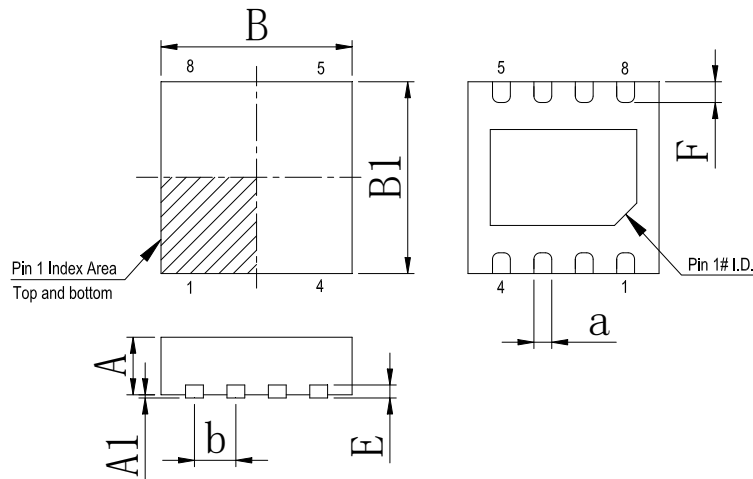

Dimensions In Millimeters(DFN-8 2*2)

Symbol:	A	A1	B	B1	E	F	a	b
Min:	0.85	0	1.90	1.90	0.15	0.25	0.18	0.50TYP
Max:	0.95	0.05	2.10	2.10	0.25	0.45	0.30	

Revision History

DATE	REVISION	PAGE
2014-6-4	New	1-11
2023-8-28	Update encapsulation type、 Update Lead Temperature、 Updated DIP-8 dimension	1、 2、 8

IMPORTANT STATEMENT:

Hanschip Semiconductor reserves the right to change its products and services without notice. Before ordering, the customer shall obtain the latest relevant information and verify whether the information is up to date and complete. Hanschip Semiconductor does not assume any responsibility or obligation for the altered documents.

Customers are responsible for complying with safety standards and taking safety measures when using Hanschip Semiconductor products for system design and machine manufacturing. You will bear all the following responsibilities: select the appropriate Hanschip Semiconductor products for your application; Design, validate and test your application; Ensure that your application meets the appropriate standards and any other safety, security or other requirements. To avoid the occurrence of potential risks that may lead to personal injury or property loss.

Hanschip Semiconductor products have not been approved for applications in life support, military, aerospace and other fields, and Hanschip Semiconductor will not bear the consequences caused by the application of products in these fields. All problems, responsibilities and losses arising from the user's use beyond the applicable area of the product shall be borne by the user and have nothing to do with Hanschip Semiconductor, and the user shall not claim any compensation liability against Hanschip Semiconductor by the terms of this Agreement.

The technical and reliability data (including data sheets), design resources (including reference designs), application or other design suggestions, network tools, safety information and other resources provided for the performance of semiconductor products produced by Hanschip Semiconductor are not guaranteed to be free from defects and no warranty, express or implied, is made. The use of testing and other quality control technologies is limited to the quality assurance scope of Hanschip Semiconductor. Not all parameters of each device need to be tested.

The documentation of Hanschip Semiconductor authorizes you to use these resources only for developing the application of the product described in this document. You have no right to use any other Hanschip Semiconductor intellectual property rights or any third party intellectual property rights. It is strictly forbidden to make other copies or displays of these resources. You should fully compensate Hanschip Semiconductor and its agents for any claims, damages, costs, losses and debts caused by the use of these resources. Hanschip Semiconductor accepts no liability for any loss or damage caused by infringement.

单击下面可查看定价，库存，交付和生命周期等信息

[>>HGC\(深圳汉芯\)](#)