

## Precision Micropower Shunt Voltage Reference

### Features

- Small SOT-23 package
- No output capacitor required
- Tolerates capacitive loads
- LM4040 is available in fixed reverse breakdown voltages of 2.048V, 2.500V, 3.000V, 3.300V 4.096V, 5.000V, 8.192V and 10V.
- LM4041 is available with a fixed 1.225V or an adjustable reverse break- down voltage.



### Key Specifications

- Tight output tolerances and low temperature coefficient
  - Maximum 0.1%, 100ppm/°C – A Grade
  - Maximum 0.2%, 100ppm/°C – B Grade
  - Maximum 0.5%, 100ppm/°C – C Grade
  - Maximum 1.0%, 150ppm/°C – D Grade
  - Maximum 2.0%, 150ppm/°C – E Grade
- Low output noise (10Hz to 100Hz)
  - LM4040 35uVRMS (typ)
  - LM4041 20uVRMS (typ)
- Wide operating current range
  - LM4040 60 uA to 15mA
  - LM4041 60 uA to 12mA
- Industrial temperature range: -40°C to +85°C
- Low temperature coefficient: 100ppm/ °C (max)

### Applications

- Battery-Powered Equipment
- Data Acquisition Systems
- Instrumentation
- Process Control
- Energy Management
- Product Testing
- Automotive Electronics
- Precision Audio Components

**Ordering Information**

DEVICE	Package Type	MARKING	Packing	Packing Qty
LM4040AIM3-2.0/TR	SOT-23	FZEF,RJA	REEL	3000pcs/reel
LM4040BIM3-2.0/TR	SOT-23	FZEG,RJB	REEL	3000pcs/reel
LM4040CIM3-2.0/TR	SOT-23	FZEH,RJC	REEL	3000pcs/reel
LM4040DIM3-2.0/TR	SOT-23	FZEI,RJD	REEL	3000pcs/reel
LM4040AIM3-2.5/TR	SOT-23	FZEJ,R2A	REEL	3000pcs/reel
LM4040BIM3-2.5/TR	SOT-23	FZEK,R2B	REEL	3000pcs/reel
LM4040CIM3-2.5/TR	SOT-23	FZEL,R2C	REEL	3000pcs/reel
LM4040DIM3-2.5/TR	SOT-23	EZEM,R2D	REEL	3000pcs/reel
LM4040AIM3-3.0/TR	SOT-23	FZEN,RKA	REEL	3000pcs/reel
LM4040BIM3-3.0/TR	SOT-23	FZEO,RKB	REEL	3000pcs/reel
LM4040CIM3-3.0/TR	SOT-23	FZEP,RKC	REEL	3000pcs/reel
LM4040DIM3-3.0/TR	SOT-23	FZEQ,RKD	REEL	3000pcs/reel
LM4040AIM3-3.3/TR	SOT-23	ANY	REEL	3000pcs/reel
LM4040BIM3-3.3/TR	SOT-23	ANZ	REEL	3000pcs/reel
LM4040CIM3-3.3/TR	SOT-23	AOA	REEL	3000pcs/reel
LM4040DIM3-3.3/TR	SOT-23	AOB	REEL	3000pcs/reel
LM4040AIM3-4.1/TR	SOT-23	FZER,R4A	REEL	3000pcs/reel
LM4040BIM3-4.1/TR	SOT-23	FZES,R4B	REEL	3000pcs/reel
LM4040CIM3-4.1/TR	SOT-23	FZET,R4C	REEL	3000pcs/reel
LM4040DIM3-4.1/TR	SOT-23	FZEU,R4D	REEL	3000pcs/reel
LM4040AIM3-5.0/TR	SOT-23	FZEV,R5A	REEL	3000pcs/reel
LM4040BIM3-5.0/TR	SOT-23	FZEW,R5B	REEL	3000pcs/reel
LM4040CIM3-5.0/TR	SOT-23	FZEX,R5C	REEL	3000pcs/reel
LM4040DIM3-5.0/TR	SOT-23	FZEY,R5D	REEL	3000pcs/reel
LM4040AIM3-8.2/TR	SOT-23	R8A	REEL	3000pcs/reel
LM4040BIM3-8.2/TR	SOT-23	R8B	REEL	3000pcs/reel
LM4040CIM3-8.2/TR	SOT-23	R8C	REEL	3000pcs/reel
LM4040DIM3-8.2/TR	SOT-23	R8D	REEL	3000pcs/reel
LM4040AIM3-10.0/TR	SOT-23	R0A	REEL	3000pcs/reel
LM4040BIM3-10.0/TR	SOT-23	R0B	REEL	3000pcs/reel
LM4040CIM3-10.0/TR	SOT-23	R0C	REEL	3000pcs/reel
LM4040DIM3-10.0/TR	SOT-23	R0D	REEL	3000pcs/reel
LM4041AIM3-1.2/TR	SOT-23	R1A	REEL	3000pcs/reel
LM4041BIM3-1.2/TR	SOT-23	R1B	REEL	3000pcs/reel
LM4041CIM3-1.2/TR	SOT-23	R1C	REEL	3000pcs/reel
LM4041DIM3-1.2/TR	SOT-23	R1D	REEL	3000pcs/reel
LM4041EIM3-1.2/TR	SOT-23	R1E	REEL	3000pcs/reel
LM4041CIM3-ADJ/TR	SOT-23	RAC	REEL	3000pcs/reel
LM4041DIM3-ADJ/TR	SOT-23	RAD	REEL	3000pcs/reel

## General Description

Ideal for space critical applications, the LM4040 and LM4041 precision voltage references are available in the subminiature (3mm × 1.3mm) SOT-23 surface-mount package.

The LM4040 is available in fixed reverse breakdown voltages of 2.048V, 2.500V, 3.000V, 3.300V, 4.096V, 5.000V, 8.192V and 10V. The LM4041 is available with a fixed 1.225V or an adjustable reverse breakdown voltage.

The LM4040 and LM4041's advanced design eliminates the need for an external stabilizing capacitor while ensuring stability with any capacitive load, making them easy to use.

The minimum operating current ranges from 60uA for the LM4041-1.2 to 74uA for the LM4040-5.0. LM4040 versions have a maximum operating current of 15mA. LM4041 versions have a maximum operating current of 12mA.

The LM4040 and LM4041 utilizes zener-zap reverse breakdown voltage trim during wafer sort to ensure that the prime parts have an accuracy of better than  $\pm 0.1\%$  (A grade) at 25°C. Bandgap reference temperature drift correction and low dynamic impedance ensure stable reverse breakdown voltage accuracy over a wide range of operating temperatures and currents.

## Pin Configuration

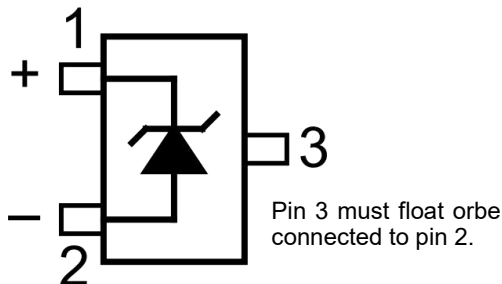

Fixed Version  
SOT-23(M3)Package  
Top View

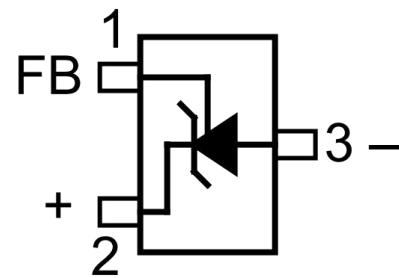

Adjustable Version  
SOT-23(M3)Package  
Top View

Functional Diagram

LM4040, LM4041 Fixed

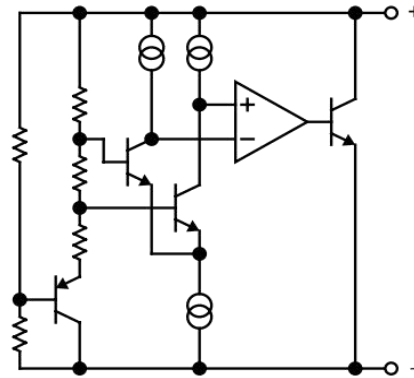

LM4041 Adjustable

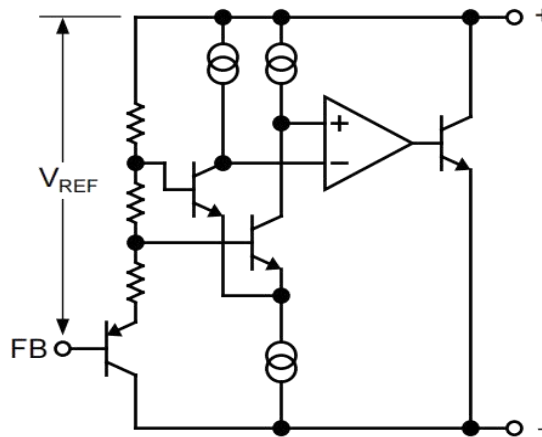

Typical Applications

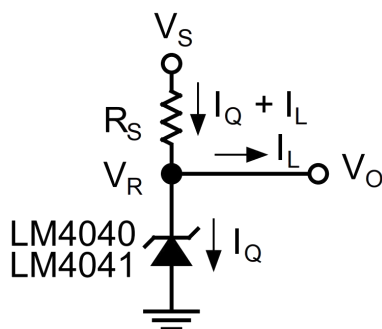

Figure 1. LM4040,LM4041 Fixed Shunt Regulator Application

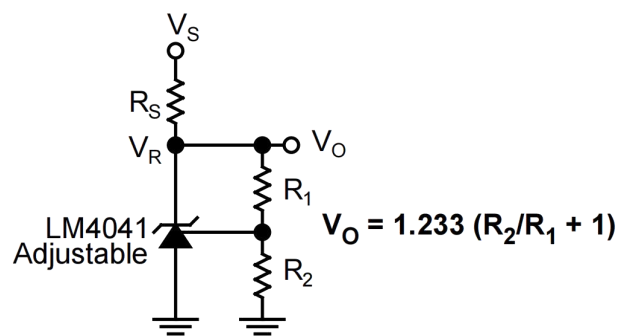

Figure 2. LM4041 Adjustable Shunt Regulator Application

**ABSOLUTE MAXIMUM RATINGS**

Parameter	Value	Unit
Reverse Current	20	mA
Forward Current	10	mA
Maximum Output Voltage		
LM4041-Adjustable	15	V
Power Dissipation at TA = 25°C (Note 2)	306	mW
Storage Temperature	-65 to +150	°C
Lead Temperature (TL) (Soldering, 10 seconds)	260	°C
ESD Susceptibility		
Human Body Model (Note 3)	2	kV
Machine Model (Note 3)	200	V

**Note:** Absolute Maximum Ratings indicate limits beyond which damage to the device may occur. Operating Ratings indicate conditions for which the device is intended to be functional, but specific performance is not ensured.

**Operating Ratings** (Notes 1 and 2)

Parameter	Value
Temperature Range( $T_{MIN} \leq T_A \leq T_{MAX}$ )	$-40^{\circ}\text{C} \leq T_A \leq +85^{\circ}\text{C}$
Reverse Current	
LM4040-2.0	60uA to 15mA
LM4040-2.5	60uA to 15mA
LM4040-3.0	62uA to 15mA
LM4040-3.3	62uA to 15mA
LM4040-4.1	68uA to 15mA
LM4040-5.0	74uA to 15mA
LM4040-8.2	91uA to 15mA
LM4040-10.0	100uA to 15mA
LM4041-1.2	60uA to 12mA
LM4041-ADJ	60uA to 12mA
Output Voltage Range	
LM4041-ADJ	1.24V to 10V

**LM4040-2.0 Electrical Characteristics**

**Boldface** limits apply for  $T_A = T_J = T_{MIN}$  to  $T_{MAX}$ ; all other limits  $T_A = T_J = 25^\circ\text{C}$ . The grades A, B, C, and D designate initial Reverse Breakdown Voltage tolerance of  $\pm 0.1\%$ ,  $\pm 0.2\%$ ,  $\pm 0.5\%$ , and  $\pm 1.0\%$  respectively.

Symbol	Parameter	Conditions	Typical (Note4)	LM4040AIM3 Limits (Note 5)	LM4040BIM3 Limits (Note 5)	LM4040CIM3 Limits (Note 5)	Units (Limit)
$V_R$	Reverse Breakdown Voltage	$I_R = 100\mu\text{A}$	2.048				V
	Reverse Breakdown Voltage Tolerance	$I_R = 100\mu\text{A}$		$\pm 2.0$ <b><math>\pm 15</math></b>	$\pm 4.0$ <b><math>\pm 17</math></b>	$\pm 10$ <b><math>\pm 23</math></b>	mV (max) mV (max)
$I_{RMIN}$	Minimum Operating Current		45	60 <b>65</b>	60 <b>65</b>	45 <b>65</b>	$\mu\text{A}$ $\mu\text{A}$ (max) $\mu\text{A}$ (max)
$\Delta V_R/\Delta T$	Average Reverse Breakdown Voltage Temperature Coefficient	$I_R = 10\text{mA}$ $I_R = 1\text{mA}$ $I_R = 100\mu\text{A}$	$\pm 20$ $\pm 15$ $\pm 15$	<b><math>\pm 100</math></b>	<b><math>\pm 100</math></b>	<b><math>\pm 100</math></b>	ppm/ $^\circ\text{C}$ ppm/ $^\circ\text{C}$ (max) ppm/ $^\circ\text{C}$ (max)
$\Delta V_R/\Delta I_R$	Reverse Breakdown Voltage Change with Operating Current Change	$I_{RMIN} \leq I_R 1\text{mA}$	0.3	0.8 <b>1.0</b>	0.8 <b>1.0</b>	0.8 <b>1.0</b>	mV mV (max) mV (max)
		$1\text{mA} \leq I_R 15\text{mA}$	2.5	6 <b>8</b>	6 <b>8</b>	6 <b>8</b>	mV mV (max) mV (max)
$Z_R$	Reverse Dynamic Impedance	$I_R = 1\text{mA}, f = 120\text{Hz}$ $I_{AC} = 0.1 I_R$	0.3	0.8	0.8	0.9	$\Omega$ $\Omega$ (max)
$e_N$	Wideband Noise	$I_R = 100\mu\text{A}$ $10\text{Hz} \leq f \leq 10\text{kHz}$	35				$\mu\text{V}_{RMS}$
$\Delta V_R$	Reverse Breakdown Voltage Long Term Stability	$t = 1000\text{hrs}$ $T = 25^\circ\text{C} \pm 0.1^\circ\text{C}$ $I_R = 100\mu\text{A}$	120				ppm

Symbol	Parameter	Conditions	Typical (Note4)	LM4040DIM3 Limits (Note 5)	Units (Limit)
$V_R$	Reverse Breakdown Voltage	$I_R = 100\mu\text{A}$	2.048		V
	Reverse Breakdown Voltage Tolerance	$I_R = 100\mu\text{A}$		$\pm 20$ <b><math>\pm 41</math></b>	mV (max) mV (max)
$I_{RMIN}$	Minimum Operating Current		45	45 <b>70</b>	$\mu\text{A}$ $\mu\text{A}$ (max) $\mu\text{A}$ (max)
$\Delta V_R/\Delta T$	Average Reverse Breakdown Voltage Temperature Coefficient	$I_R = 10\text{mA}$ $I_R = 1\text{mA}$ $I_R = 100\mu\text{A}$	$\pm 20$ $\pm 15$ $\pm 15$	<b><math>\pm 150</math></b>	ppm/ $^\circ\text{C}$ ppm/ $^\circ\text{C}$ (max) ppm/ $^\circ\text{C}$ (max)
$\Delta V_R/\Delta I_R$	Reverse Breakdown Voltage Change with Operating Current Change	$I_{RMIN} \leq I_R 1\text{mA}$	0.3	1.0 <b>1.2</b>	mV mV (max) mV (max)
		$1\text{mA} \leq I_R 15\text{mA}$	2.5	8.0 <b>10.0</b>	mV mV (max) mV (max)
$Z_R$	Reverse Dynamic Impedance	$I_R = 1\text{mA}, f = 120\text{Hz}$ $I_{AC} = 0.1 I_R$	0.3	1.1	$\Omega$ $\Omega$ (max)
$e_N$	Wideband Noise	$I_R = 100\mu\text{A}$ $10\text{Hz} \leq f \leq 10\text{kHz}$	35		$\mu\text{V}_{RMS}$
$\Delta V_R$	Reverse Breakdown Voltage Long Term Stability	$t = 1000\text{hrs}$ $T = 25^\circ\text{C} \pm 0.1^\circ\text{C}$ $I_R = 100\mu\text{A}$	120		ppm

**LM4040-2.5 Electrical Characteristics**

**Boldface** limits apply for  $T_A = T_J = T_{MIN}$  to  $T_{MAX}$ ; all other limits  $T_A = T_J = 25^\circ\text{C}$ . The grades A, B, C, and D designate initial Reverse Breakdown Voltage tolerance of  $\pm 0.1\%$ ,  $\pm 0.2\%$ ,  $\pm 0.5\%$ , and  $\pm 1.0\%$  respectively.

Symbol	Parameter	Conditions	Typical (Note4)	LM4040AIM3 Limits (Note 5)	LM4040BIM3 Limits (Note 5)	LM4040CIM3 Limits (Note 5)	Units (Limit)
$V_R$	Reverse Breakdown Voltage	$I_R = 100\mu\text{A}$	2.500				V
	Reverse Breakdown Voltage Tolerance	$I_R = 100\mu\text{A}$		$\pm 2.5$ <b><math>\pm 19</math></b>	$\pm 5.0$ <b><math>\pm 21</math></b>	$\pm 12$ <b><math>\pm 29</math></b>	mV (max) mV (max)
$I_{RMIN}$	Minimum Operating Current		45	60 <b>65</b>	60 <b>65</b>	60 <b>65</b>	$\mu\text{A}$ $\mu\text{A}$ (max) $\mu\text{A}$ (max)
$\Delta V_R/\Delta T$	Average Reverse Breakdown Voltage Temperature Coefficient	$I_R = 10\text{mA}$ $I_R = 1\text{mA}$ $I_R = 100\mu\text{A}$	$\pm 20$ $\pm 15$ $\pm 15$	<b><math>\pm 100</math></b>	<b><math>\pm 100</math></b>	<b><math>\pm 100</math></b>	ppm/ $^\circ\text{C}$ ppm/ $^\circ\text{C}$ (max) ppm/ $^\circ\text{C}$ (max)
$\Delta V_R/\Delta I_R$	Reverse Breakdown Voltage Change with Operating Current Change	$I_{RMIN} \leq I_R 1\text{mA}$	0.3	<b>1.0</b>	<b>1.0</b>	<b>1.0</b>	mV mV (max)
		$1\text{mA} \leq I_R 15\text{mA}$	2.5	6 <b>8</b>	6 <b>8</b>	6 <b>8</b>	mV (max) mV (max)
$Z_R$	Reverse Dynamic Impedance	$I_R = 1\text{mA}$ , $f = 120\text{Hz}$ $I_{AC} = 0.1 I_R$	0.3	<b>0.8</b>	<b>0.8</b>	<b>0.9</b>	$\Omega$ $\Omega$ (max)
$e_N$	Wideband Noise	$I_R = 100\mu\text{A}$ $10\text{Hz} \leq f \leq 10\text{kHz}$	35				$\mu\text{V}_{RMS}$
$\Delta V_R$	Reverse Breakdown Voltage Long Term Stability	$t = 1000\text{hrs}$ $T = 25^\circ\text{C} \pm 0.1^\circ\text{C}$ $I_R = 100\mu\text{A}$	120				ppm

Symbol	Parameter	Conditions	Typical (Note4)	LM4040DIM3 Limits (Note 5)	Units (Limit)
$V_R$	Reverse Breakdown Voltage	$I_R = 100\mu\text{A}$	2.500		V
	Reverse Breakdown Voltage Tolerance	$I_R = 100\mu\text{A}$		$\pm 25$ <b><math>\pm 49</math></b>	mV (max) mV (max)
$I_{RMIN}$	Minimum Operating Current		45	65 <b>70</b>	$\mu\text{A}$ $\mu\text{A}$ (max) $\mu\text{A}$ (max)
$\Delta V_R/\Delta T$	Average Reverse Breakdown Voltage Temperature Coefficient	$I_R = 10\text{mA}$ $I_R = 1\text{mA}$ $I_R = 100\mu\text{A}$	$\pm 20$ $\pm 15$ $\pm 15$	<b><math>\pm 150</math></b>	ppm/ $^\circ\text{C}$ ppm/ $^\circ\text{C}$ (max) ppm/ $^\circ\text{C}$ (max)
$\Delta V_R/\Delta I_R$	Reverse Breakdown Voltage Change with Operating Current Change	$I_{RMIN} \leq I_R 1\text{mA}$	0.3	<b>1.2</b>	mV mV (max)
		$1\text{mA} \leq I_R 15\text{mA}$	2.5	8 <b>10</b>	mV (max) mV (max)
$Z_R$	Reverse Dynamic Impedance	$I_R = 1\text{mA}$ , $f = 120\text{Hz}$ $I_{AC} = 0.1 I_R$	0.3	1.1	$\Omega$ $\Omega$ (max)
$e_N$	Wideband Noise	$I_R = 100\mu\text{A}$ $10\text{Hz} \leq f \leq 10\text{kHz}$	35		$\mu\text{V}_{RMS}$
$\Delta V_R$	Reverse Breakdown Voltage Long Term Stability	$t = 1000\text{hrs}$ $T = 25^\circ\text{C} \pm 0.1^\circ\text{C}$ $I_R = 100\mu\text{A}$	120		ppm

## LM4040-3.0 Electrical Characteristics

**Boldface** limits apply for  $T_A = T_J = T_{MIN}$  to  $T_{MAX}$ ; all other limits  $T_A = T_J = 25^\circ\text{C}$ . The grades A, B, C, and D designate initial Reverse Breakdown Voltage tolerance of  $\pm 0.1\%$ ,  $\pm 0.2\%$ ,  $\pm 0.5\%$ , and  $\pm 1.0\%$  respectively.

Symbol	Parameter	Conditions	Typical (Note4)	LM4040AIM3 Limits (Note 5)	LM4040BIM3 Limits (Note 5)	LM4040CIM3 Limits (Note 5)	Units (Limit)
$V_R$	Reverse Breakdown Voltage	$I_R = 100\mu\text{A}$	3.000				V
	Reverse Breakdown Voltage Tolerance	$I_R = 100\mu\text{A}$		$\pm 3.0$ <b><math>\pm 22</math></b>	$\pm 6.0$ <b><math>\pm 26</math></b>	$\pm 15$ <b><math>\pm 34</math></b>	mV (max) mV (max)
$I_{RMIN}$	Minimum Operating Current		45	60 <b>67</b>	60 <b>67</b>	60 <b>67</b>	$\mu\text{A}$ $\mu\text{A}$ (max) $\mu\text{A}$ (max)
$\Delta V_R/\Delta T$	Average Reverse Breakdown Voltage Temperature Coefficient	$I_R = 10\text{mA}$ $I_R = 1\text{mA}$ $I_R = 100\mu\text{A}$	$\pm 20$ $\pm 15$ $\pm 15$	<b><math>\pm 100</math></b>	<b><math>\pm 100</math></b>	<b><math>\pm 100</math></b>	ppm/ $^\circ\text{C}$ ppm/ $^\circ\text{C}$ (max) ppm/ $^\circ\text{C}$ (max)
$\Delta V_R/\Delta I_R$	Reverse Breakdown Voltage Change with Operating Current Change	$I_{RMIN} \leq I_R 1\text{mA}$	0.3	0.8 <b>1.0</b>	0.8 <b>1.0</b>	<b>0.8</b> <b>1.1</b>	mV mV (max) mV (max)
		$1\text{mA} \leq I_R 15\text{mA}$	2.7	6 <b>9</b>	6 <b>9</b>	6 <b>9</b>	mV mV (max) mV (max)
$Z_R$	Reverse Dynamic Impedance	$I_R = 1\text{mA}$ , $f = 120\text{Hz}$ $I_{AC} = 0.1 I_R$	0.4	<b>0.9</b>	<b>0.9</b>	<b>0.9</b>	$\Omega$ $\Omega$ (max)
$e_N$	Wideband Noise	$I_R = 100\mu\text{A}$ $10\text{Hz} \leq f \leq 10\text{kHz}$	45				$\mu\text{V}_{RMS}$
$\Delta V_R$	Reverse Breakdown Voltage Long Term Stability	$t = 1000\text{hrs}$ $T = 25^\circ\text{C} \pm 0.1^\circ\text{C}$ $I_R = 100\mu\text{A}$	120				ppm

Symbol	Parameter	Conditions	Typical (Note4)	LM4040DIM3 Limits (Note 5)	Units (Limit)
$V_R$	Reverse Breakdown Voltage	$I_R = 100\mu\text{A}$	3.000		V
	Reverse Breakdown Voltage Tolerance	$I_R = 100\mu\text{A}$		$\pm 30$ <b><math>\pm 59</math></b>	mV (max) mV (max)
$I_{RMIN}$	Minimum Operating Current		45	65 <b>70</b>	$\mu\text{A}$ $\mu\text{A}$ (max) $\mu\text{A}$ (max)
$\Delta V_R/\Delta T$	Average Reverse Breakdown Voltage Temperature Coefficient	$I_R = 10\text{mA}$ $I_R = 1\text{mA}$ $I_R = 100\mu\text{A}$	$\pm 20$ $\pm 15$ $\pm 15$	<b><math>\pm 150</math></b>	ppm/ $^\circ\text{C}$ ppm/ $^\circ\text{C}$ (max) ppm/ $^\circ\text{C}$ (max)
$\Delta V_R/\Delta I_R$	Reverse Breakdown Voltage Change with Operating Current Change	$I_{RMIN} \leq I_R 1\text{mA}$	0.3	1.1 <b>1.3</b>	mV mV (max) mV (max)
		$1\text{mA} \leq I_R 15\text{mA}$	2.7	8 <b>11</b>	mV mV (max) mV (max)
$Z_R$	Reverse Dynamic Impedance	$I_R = 1\text{mA}$ , $f = 120\text{Hz}$ $I_{AC} = 0.1 I_R$	0.3	1.1	$\Omega$ $\Omega$ (max)
$e_N$	Wideband Noise	$I_R = 100\mu\text{A}$ $10\text{Hz} \leq f \leq 10\text{kHz}$	45		$\mu\text{V}_{RMS}$
$\Delta V_R$	Reverse Breakdown Voltage Long Term Stability	$t = 1000\text{hrs}$ $T = 25^\circ\text{C} \pm 0.1^\circ\text{C}$ $I_R = 100\mu\text{A}$	120		ppm



### LM4040-3.3 Electrical Characteristics

**Boldface** limits apply for  $T_A = T_J = T_{MIN}$  to  $T_{MAX}$ ; all other limits  $T_A = T_J = 25^\circ\text{C}$ . The grades A, B, C, and D designate initial Reverse Breakdown Voltage tolerance of  $\pm 0.1\%$ ,  $\pm 0.2\%$ ,  $\pm 0.5\%$ , and  $\pm 1.0\%$  respectively.

Symbol	Parameter	Conditions	Typical (Note4)	LM4040AIM3 Limits (Note 5)	LM4040BIM3 Limits (Note 5)	LM4040CIM3 Limits (Note 5)	Units (Limit)
$V_R$	Reverse Breakdown Voltage	$I_R = 100\mu\text{A}$	3.300				V
	Reverse Breakdown Voltage Tolerance	$I_R = 100\mu\text{A}$		$\pm 3.0$ <b><math>\pm 22</math></b>	$\pm 6.0$ <b><math>\pm 26</math></b>	$\pm 15$ <b><math>\pm 34</math></b>	mV (max) mV (max)
$I_{RMIN}$	Minimum Operating Current		45	60 <b>67</b>	60 <b>67</b>	60 <b>67</b>	$\mu\text{A}$ $\mu\text{A}$ (max) $\mu\text{A}$ (max)
$\Delta V_R/\Delta T$	Average Reverse Breakdown Voltage Temperature Coefficient	$I_R = 10\text{mA}$ $I_R = 1\text{mA}$ $I_R = 100\mu\text{A}$	$\pm 20$ $\pm 15$ $\pm 15$	<b><math>\pm 100</math></b>	<b><math>\pm 100</math></b>	<b><math>\pm 100</math></b>	ppm/ $^\circ\text{C}$ ppm/ $^\circ\text{C}$ (max) ppm/ $^\circ\text{C}$ (max)
$\Delta V_R/\Delta I_R$	Reverse Breakdown Voltage Change with Operating Current Change	$I_{RMIN} \leq I_R 1\text{mA}$	0.3	0.8 <b>1.0</b>	0.8 <b>1.0</b>	<b>0.8</b> <b>1.0</b>	mV mV (max) mV (max)
		$1\text{mA} \leq I_R 15\text{mA}$	2.5	6 <b>8</b>	6 <b>8</b>	6 <b>8</b>	mV mV (max) mV (max)
$Z_R$	Reverse Dynamic Impedance	$I_R = 1\text{mA}$ , $f = 120\text{Hz}$ $I_{AC} = 0.1 I_R$	0.3	<b>0.8</b>	<b>0.8</b>	<b>0.9</b>	$\Omega$ $\Omega$ (max)
$e_N$	Wideband Noise	$I_R = 100\mu\text{A}$ $10\text{Hz} \leq f \leq 10\text{kHz}$	50				$\mu\text{V}_{RMS}$
$\Delta V_R$	Reverse Breakdown Voltage Long Term Stability	$t = 1000\text{hrs}$ $T = 25^\circ\text{C} \pm 0.1^\circ\text{C}$ $I_R = 100\mu\text{A}$	120				ppm

Symbol	Parameter	Conditions	Typical (Note4)	LM4040DIM3 Limits (Note 5)	Units (Limit)
$V_R$	Reverse Breakdown Voltage	$I_R = 100\mu\text{A}$	3.300		V
	Reverse Breakdown Voltage Tolerance	$I_R = 100\mu\text{A}$		$\pm 30$ <b><math>\pm 59</math></b>	mV (max) mV (max)
$I_{RMIN}$	Minimum Operating Current		45	65 <b>70</b>	$\mu\text{A}$ $\mu\text{A}$ (max) $\mu\text{A}$ (max)
$\Delta V_R/\Delta T$	Average Reverse Breakdown Voltage Temperature Coefficient	$I_R = 10\text{mA}$ $I_R = 1\text{mA}$ $I_R = 100\mu\text{A}$	$\pm 20$ $\pm 15$ $\pm 15$	<b><math>\pm 150</math></b>	ppm/ $^\circ\text{C}$ ppm/ $^\circ\text{C}$ (max) ppm/ $^\circ\text{C}$ (max)
$\Delta V_R/\Delta I_R$	Reverse Breakdown Voltage Change with Operating Current Change	$I_{RMIN} \leq I_R 1\text{mA}$	0.3	1.1 <b>1.2</b>	mV mV (max) mV (max)
		$1\text{mA} \leq I_R 15\text{mA}$	2.7	8 <b>10</b>	mV mV (max) mV (max)
$Z_R$	Reverse Dynamic Impedance	$I_R = 1\text{mA}$ , $f = 120\text{Hz}$ $I_{AC} = 0.1 I_R$	0.3	1.1	$\Omega$ $\Omega$ (max)
$e_N$	Wideband Noise	$I_R = 100\mu\text{A}$ $10\text{Hz} \leq f \leq 10\text{kHz}$	45		$\mu\text{V}_{RMS}$
$\Delta V_R$	Reverse Breakdown Voltage Long Term Stability	$t = 1000\text{hrs}$ $T = 25^\circ\text{C} \pm 0.1^\circ\text{C}$ $I_R = 100\mu\text{A}$	120		ppm

**LM4040-4.1 Electrical Characteristics**

**Boldface** limits apply for  $T_A = T_J = T_{MIN}$  to  $T_{MAX}$ ; all other limits  $T_A = T_J = 25^\circ\text{C}$ . The grades A, B, C, and D designate initial Reverse Breakdown Voltage tolerance of  $\pm 0.1\%$ ,  $\pm 0.2\%$ ,  $\pm 0.5\%$ , and  $\pm 1.0\%$  respectively.

Symbol	Parameter	Conditions	Typical (Note 4)	LM4040AIM3 Limits (Note 5)	LM4040BIM3 Limits (Note 5)	Units(Limit)
$V_R$	Reverse Breakdown Voltage	$I_R = 100\mu\text{A}$	4.096			V
	Reverse Breakdown Voltage Tolerance	$I_R = 100\mu\text{A}$		$\pm 4.1$ <b><math>\pm 31</math></b>	$\pm 8.2$ <b><math>\pm 35</math></b>	mV (max) mV (max)
$I_{RMIN}$	Minimum Operating Current		50	68 <b>73</b>	68 <b>73</b>	$\mu\text{A}$ $\mu\text{A}$ (max) $\mu\text{A}$ (max)
$\Delta V_R/\Delta T$	Average Reverse Breakdown Voltage Temperature Coefficient	$I_R = 10\text{m}$ $A I_R = 1\text{m}$ $A I_R = 100\mu\text{A}$	$\pm 30$ $\pm 20$ $\pm 20$	<b><math>\pm 100</math></b>	<b><math>\pm 100</math></b>	ppm/ $^\circ\text{C}$ ppm/ $^\circ\text{C}$ (max) ppm/ $^\circ\text{C}$ (max)
$\Delta V_R/\Delta I_R$	Reverse Breakdown Voltage Change with Operating Current Change	$I_{RMIN} \cong I_R 1\text{mA}$	0.5	0.9 <b>1.2</b>	0.9 <b>1.2</b>	mV mV (max) mV (max)
		$1\text{mA} \cong I_R 15\text{mA}$	3.5	7.0 <b>10.0</b>	7.0 <b>10.0</b>	mV mV (max) mV (max)
$Z_R$	Reverse Dynamic Impedance	$I_R = 1\text{mA}$ , $f = 120\text{Hz}$ $I_{AC} = 0.1 I_R$	0.5	1.0	1.0	$\Omega$ $\Omega$ (max)
$e_N$	Wideband Noise	$I_R = 100\mu\text{A}$ $10\text{Hz} \cong f \cong 10\text{kHz}$	80			$\mu\text{V}_{RMS}$
$\Delta V_R$	Reverse Breakdown Voltage Long Term Stability	$t = 1000\text{hrs}$ $T = 25^\circ\text{C} \pm 0.1^\circ\text{C}$ $I_R = 100\mu\text{A}$	120			ppm

Symbol	Parameter	Conditions	Typical (Note 4)	LM4040CIM3 Limits (Note 5)	LM4040DIM3 Limits (Note 5)	Units (Limits)
$V_R$	Reverse Breakdown Voltage	$I_R = 100\mu\text{A}$	4.096			V
	Reverse Breakdown Voltage Tolerance	$I_R = 100\mu\text{A}$		$\pm 20$ <b><math>\pm 47</math></b>	$\pm 41$ <b><math>\pm 81</math></b>	mV (max) mV (max)
$I_{RMIN}$	Minimum Operating Current		50	68 <b>73</b>	73 <b>78</b>	$\mu\text{A}$ $\mu\text{A}$ (max) $\mu\text{A}$ (max)
$\Delta V_R/\Delta T$	Average Reverse Breakdown Voltage Temperature Coefficient	$I_R = 10\text{mA}$ $I_R = 1\text{mA}$ $I_R = 100\mu\text{A}$	$\pm 30$ $\pm 20$ $\pm 20$	<b><math>\pm 100</math></b>	<b><math>\pm 150</math></b>	ppm/ $^\circ\text{C}$ ppm/ $^\circ\text{C}$ (max) ppm/ $^\circ\text{C}$ (max)
$\Delta V_R/\Delta I_R$	Reverse Breakdown Voltage Change with Operating Current Change	$I_{RMIN} \cong I_R 1\text{mA}$	0.5	0.9 <b>1.2</b>	1.2 <b>1.5</b>	mV mV (max) mV (max)
		$1\text{mA} \cong I_R 15\text{mA}$	3.0	7.0 <b>10.0</b>	9.0 <b>13.0</b>	mV mV (max) mV (max)
$Z_R$	Reverse Dynamic Impedance	$I_R = 1\text{mA}$ , $f = 120\text{Hz}$ $I_{AC} = 0.1 I_R$	0.5	1.0	1.3	$\Omega$ $\Omega$ (max)
$e_N$	Wideband Noise	$I_R = 100\mu\text{A}$ $10\text{Hz} \cong f \cong 10\text{kHz}$	80			$\mu\text{V}_{RMS}$
$\Delta V_R$	Reverse Breakdown Voltage Long Term Stability	$t = 1000\text{hrs}$ $T = 25^\circ\text{C} \pm 0.1^\circ\text{C}$ $I_R = 100\mu\text{A}$	120			ppm

**LM4040-5.0 Electrical Characteristics**

**Boldface** limits apply for  $T_A = T_J = T_{MIN}$  to  $T_{MAX}$ ; all other limits  $T_A = T_J = 25^\circ C$ . The grades A, B, C, and D designate initial Reverse Breakdown Voltage tolerance of  $\pm 0.1\%$ ,  $\pm 0.2\%$ ,  $\pm 0.5\%$ , and  $\pm 1.0\%$  respectively.

Symbol	Parameter	Conditions	Typical (Note4)	LM4040AIM3 Limits (Note5)	LM4040BIM3 Limits (Note5)	Units(Limit)
$V_R$	Reverse Breakdown Voltage	$I_R = 100\mu A$	5.000			V
	Reverse Breakdown Voltage Tolerance	$I_R = 100\mu A$		$\pm 5.0$ <b><math>\pm 38</math></b>	$\pm 10$ <b><math>\pm 43</math></b>	mV (max) mV (max)
$I_{RMIN}$	Minimum Operating Current		54	74 <b>80</b>	74 <b>80</b>	$\mu A$ $\mu A$ (max) $\mu A$ (max)
$\Delta V_R/\Delta T$	Average Reverse Breakdown Voltage Temperature Coefficient	$I_R = 10mA$ $I_R = 1mA$ $I_R = 100\mu A$	$\pm 30$ $\pm 20$ $\pm 20$	<b><math>\pm 100</math></b>	<b><math>\pm 100</math></b>	ppm/ $^\circ C$ ppm/ $^\circ C$ (max) ppm/ $^\circ C$ (max)
$\Delta V_R/\Delta I_R$	Reverse Breakdown Voltage Change with Operating Current Change	$I_{RMIN} \cong I_R 1mA$	0.5	1.0 <b>1.4</b>	1.0 <b>1.4</b>	mV mV (max) mV (max)
		$1mA \cong I_R 15mA$	3.5	8.0 <b>12.0</b>	8.0 <b>12.0</b>	mV mV (max) mV (max)
$Z_R$	Reverse Dynamic Impedance	$I_R = 1mA, f = 120Hz$ $I_{AC} = 0.1 I_R$	0.5	1.1	1.1	$\Omega$ $\Omega$ (max)
$e_N$	Wideband Noise	$I_R = 100\mu A$ $10Hz \cong f \cong 10kHz$	80			$\mu V_{RMS}$
$\Delta V_R$	Reverse Breakdown Voltage Long Term Stability	$t = 1000hrs$ $T = 25^\circ C \pm 0.1^\circ C$ $I_R = 100\mu A$	120			ppm

Symbol	Parameter	Conditions	Typical (Note 4)	LM4040CIM3 Limits (Note 5)	LM4040DIM3 Limits (Note 5)	Units (Limits)
$V_R$	Reverse Breakdown Voltage	$I_R = 100\mu A$	5.000			V
	Reverse Breakdown Voltage Tolerance	$I_R = 100\mu A$		$\pm 25$ <b><math>\pm 58</math></b>	$\pm 50$ <b><math>\pm 99</math></b>	mV (max) mV (max)
$I_{RMIN}$	Minimum Operating Current		54	74 <b>80</b>	79 <b>85</b>	$\mu A$ $\mu A$ (max) $\mu A$ (max)
$\Delta V_R/\Delta T$	Average Reverse Breakdown Voltage Temperature Coefficient	$I_R = 10mA$ $I_R = 1mA$ $I_R = 100\mu A$	$\pm 30$ $\pm 20$ $\pm 20$	<b><math>\pm 100</math></b>	<b><math>\pm 150</math></b>	ppm/ $^\circ C$ ppm/ $^\circ C$ (max) ppm/ $^\circ C$ (max)
$\Delta V_R/\Delta I_R$	Reverse Breakdown Voltage Change with Operating Current Change	$I_{RMIN} \cong I_R 1mA$	0.5	1.0 <b>1.4</b>	1.3 <b>1.8</b>	mV mV (max) mV (max)
		$1mA \cong I_R 15mA$	3.5	8.0 <b>12.0</b>	8.0 <b>15.0</b>	mV mV (max) mV (max)
$Z_R$	Reverse Dynamic Impedance	$I_R = 1mA, f = 120Hz$ $I_{AC} = 0.1 I_R$	0.5	1.1	1.5	$\Omega$ $\Omega$ (max)
$e_N$	Wideband Noise	$I_R = 100\mu A$ $10Hz \cong f \cong 10kHz$	80			$\mu V_{RMS}$
$\Delta V_R$	Reverse Breakdown Voltage Long Term Stability	$t = 1000hrs$ $T = 25^\circ C \pm 0.1^\circ C$ $I_R = 100\mu A$	120			ppm

## LM4040-8.2 Electrical Characteristics

**Boldface** limits apply for  $T_A = T_J = T_{MIN}$  to  $T_{MAX}$ ; all other limits  $T_A = T_J = 25^\circ\text{C}$ . The grades A, B, C, and D designate initial Reverse Breakdown Voltage tolerance of  $\pm 0.1\%$ ,  $\pm 0.2\%$ ,  $\pm 0.5\%$ , and  $\pm 1.0\%$  respectively.

Symbol	Parameter	Conditions	Typical (Note4)	LM4040AIM3 Limits (Note 5)	LM4040BIM3 Limits (Note 5)	LM4040CIM3 Limits (Note 5)	Units (Limit)
$V_R$	Reverse Breakdown Voltage	$I_R = 100\mu\text{A}$	8.192				V
	Reverse Breakdown Voltage Tolerance	$I_R = 100\mu\text{A}$		$\pm 8.2$ <b><math>\pm 61</math></b>	$\pm 16$ <b><math>\pm 70</math></b>	$\pm 41$ <b><math>\pm 94</math></b>	mV (max) mV (max)
$I_{RMIN}$	Minimum Operating Current		67	91 <b>95</b>	91 <b>95</b>	91 <b>95</b>	$\mu\text{A}$ $\mu\text{A}$ (max) $\mu\text{A}$ (max)
$\Delta V_R/\Delta T$	Average Reverse Breakdown Voltage Temperature Coefficient	$I_R = 10\text{mA}$ $I_R = 1\text{mA}$ $I_R = 100\mu\text{A}$	$\pm 40$ $\pm 20$ $\pm 20$	<b><math>\pm 100</math></b>	<b><math>\pm 100</math></b>	<b><math>\pm 100</math></b>	ppm/ $^\circ\text{C}$ ppm/ $^\circ\text{C}$ (max) ppm/ $^\circ\text{C}$ (max)
$\Delta V_R/\Delta I_R$	Reverse Breakdown Voltage Change with Operating Current Change	$I_{RMIN} \leq I_R 1\text{mA}$	0.6	1.3 <b>2.5</b>	1.3 <b>2.5</b>	1.3 <b>2.5</b>	mV mV (max) mV (max)
		$1\text{mA} \leq I_R 15\text{mA}$	7	10 <b>18</b>	10 <b>18</b>	10 <b>18</b>	mV mV (max) mV (max)
$Z_R$	Reverse Dynamic Impedance	$I_R = 1\text{mA}$ , $f = 120\text{Hz}$ $I_{AC} = 0.1 I_R$	0.6	<b>1.5</b>	<b>1.5</b>	<b>1.5</b>	$\Omega$ $\Omega$ (max)
$e_N$	Wideband Noise	$I_R = 150\mu\text{A}$ $10\text{Hz} \leq f \leq 10\text{kHz}$	130				$\mu\text{V}_{RMS}$
$\Delta V_R$	Reverse Breakdown Voltage Long Term Stability	$t = 1000\text{hrs}$ $T = 25^\circ\text{C} \pm 0.1^\circ\text{C}$ $I_R = 100\mu\text{A}$	120				ppm

Symbol	Parameter	Conditions	Typical (Note4)	LM4040DIM3 Limits (Note 5)	Units (Limit)
$V_R$	Reverse Breakdown Voltage	$I_R = 100\mu\text{A}$	8.192		V
	Reverse Breakdown Voltage Tolerance	$I_R = 100\mu\text{A}$		$\pm 82$ <b><math>\pm 162</math></b>	mV (max) mV (max)
$I_{RMIN}$	Minimum Operating Current		67	96 <b>100</b>	$\mu\text{A}$ $\mu\text{A}$ (max) $\mu\text{A}$ (max)
$\Delta V_R/\Delta T$	Average Reverse Breakdown Voltage Temperature Coefficient	$I_R = 10\text{mA}$ $I_R = 1\text{mA}$ $I_R = 100\mu\text{A}$	$\pm 40$ $\pm 20$ $\pm 20$	<b><math>\pm 150</math></b>	ppm/ $^\circ\text{C}$ ppm/ $^\circ\text{C}$ (max) ppm/ $^\circ\text{C}$ (max)
$\Delta V_R/\Delta I_R$	Reverse Breakdown Voltage Change with Operating Current Change	$I_{RMIN} \leq I_R 1\text{mA}$	0.6	1.7 <b>3</b>	mV mV (max) mV (max)
		$1\text{mA} \leq I_R 15\text{mA}$	7	15 <b>24</b>	mV mV (max) mV (max)
$Z_R$	Reverse Dynamic Impedance	$I_R = 1\text{mA}$ , $f = 120\text{Hz}$ $I_{AC} = 0.1 I_R$	0.6	1.9	$\Omega$ $\Omega$ (max)
$e_N$	Wideband Noise	$I_R = 150\mu\text{A}$ $10\text{Hz} \leq f \leq 10\text{kHz}$	130		$\mu\text{V}_{RMS}$
$\Delta V_R$	Reverse Breakdown Voltage Long Term Stability	$t = 1000\text{hrs}$ $T = 25^\circ\text{C} \pm 0.1^\circ\text{C}$ $I_R = 100\mu\text{A}$	120		ppm

**LM4040-10.0 Electrical Characteristics**

**Boldface** limits apply for  $T_A = T_J = T_{MIN}$  to  $T_{MAX}$ ; all other limits  $T_A = T_J = 25^\circ\text{C}$ . The grades A, B, C, and D designate initial Reverse Breakdown Voltage tolerance of  $\pm 0.1\%$ ,  $\pm 0.2\%$ ,  $\pm 0.5\%$ , and  $\pm 1.0\%$  respectively.

Symbol	Parameter	Conditions	Typical (Note4)	LM4040AIM3 Limits (Note 5)	LM4040BIM3 Limits (Note 5)	LM4040CIM3 Limits (Note 5)	Units (Limit)
$V_R$	Reverse Breakdown Voltage	$I_R = 100\mu\text{A}$	10.000				V
	Reverse Breakdown Voltage Tolerance	$I_R = 100\mu\text{A}$		$\pm 10$ <b><math>\pm 75</math></b>	$\pm 20$ <b><math>\pm 85</math></b>	$\pm 50$ <b><math>\pm 115</math></b>	mV (max) mV (max)
$I_{RMIN}$	Minimum Operating Current		75	100 <b>103</b>	100 <b>103</b>	100 <b>103</b>	$\mu\text{A}$ $\mu\text{A}$ (max) $\mu\text{A}$ (max)
$\Delta V_R/\Delta T$	Average Reverse Breakdown Voltage Temperature Coefficient	$I_R = 10\text{mA}$ $I_R = 1\text{mA}$ $I_R = 100\mu\text{A}$	$\pm 40$ $\pm 20$ $\pm 20$	<b><math>\pm 100</math></b>	<b><math>\pm 100</math></b>	<b><math>\pm 100</math></b>	ppm/ $^\circ\text{C}$ ppm/ $^\circ\text{C}$ (max) ppm/ $^\circ\text{C}$ (max)
$\Delta V_R/\Delta I_R$	Reverse Breakdown Voltage Change with Operating Current Change	$I_{RMIN} \leq I_R 1\text{mA}$	0.8	1.5 <b>3.5</b>	1.5 <b>3.5</b>	1.5 <b>3.5</b>	mV mV (max) mV (max)
		$1\text{mA} \leq I_R 15\text{mA}$	8	12 <b>23</b>	12 <b>23</b>	12 <b>23</b>	mV mV (max) mV (max)
$Z_R$	Reverse Dynamic Impedance	$I_R = 1\text{mA}$ , $f = 120\text{Hz}$ $I_{AC} = 0.1 I_R$	0.7	<b>1.7</b>	<b>1.7</b>	<b>1.7</b>	$\Omega$ $\Omega$ (max)
$e_N$	Wideband Noise	$I_R = 150\mu\text{A}$ $10\text{Hz} \leq f \leq 10\text{kHz}$	180				$\mu\text{V}_{RMS}$
$\Delta V_R$	Reverse Breakdown Voltage Long Term Stability	$t = 1000\text{hrs}$ $T = 25^\circ\text{C} \pm 0.1^\circ\text{C}$ $I_R = 100\mu\text{A}$	120				ppm

Symbol	Parameter	Conditions	Typical (Note4)	LM4040DIM3 Limits (Note 5)	Units (Limit)
$V_R$	Reverse Breakdown Voltage	$I_R = 100\mu\text{A}$	10.000		V
	Reverse Breakdown Voltage Tolerance	$I_R = 100\mu\text{A}$		$\pm 100$ <b><math>\pm 198</math></b>	mV (max) mV (max)
$I_{RMIN}$	Minimum Operating Current		45	110 <b>113</b>	$\mu\text{A}$ $\mu\text{A}$ (max) $\mu\text{A}$ (max)
$\Delta V_R/\Delta T$	Average Reverse Breakdown Voltage Temperature Coefficient	$I_R = 10\text{mA}$ $I_R = 1\text{mA}$ $I_R = 100\mu\text{A}$	$\pm 40$ $\pm 20$ $\pm 20$	<b><math>\pm 150</math></b>	ppm/ $^\circ\text{C}$ ppm/ $^\circ\text{C}$ (max) ppm/ $^\circ\text{C}$ (max)
$\Delta V_R/\Delta I_R$	Reverse Breakdown Voltage Change with Operating Current Change	$I_{RMIN} \leq I_R 1\text{mA}$	0.8	2 <b>4</b>	mV mV (max) mV (max)
		$1\text{mA} \leq I_R 15\text{mA}$	8	18 <b>29</b>	mV mV (max) mV (max)
$Z_R$	Reverse Dynamic Impedance	$I_R = 1\text{mA}$ , $f = 120\text{Hz}$ $I_{AC} = 0.1 I_R$	0.7	2.3	$\Omega$ $\Omega$ (max)
$e_N$	Wideband Noise	$I_R = 150\mu\text{A}$ $10\text{Hz} \leq f \leq 10\text{kHz}$	180		$\mu\text{V}_{RMS}$
$\Delta V_R$	Reverse Breakdown Voltage Long Term Stability	$t = 1000\text{hrs}$ $T = 25^\circ\text{C} \pm 0.1^\circ\text{C}$ $I_R = 100\mu\text{A}$	120		ppm

**LM4040 Typical Characteristics**

**Temperature Drift for Different Average Temperature Coefficient**

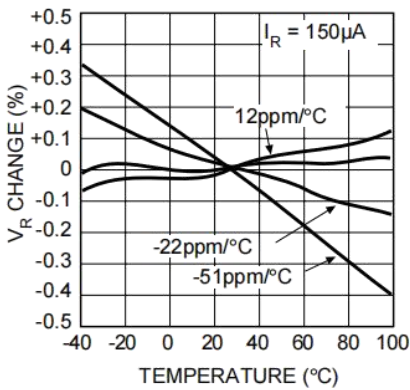

**Output Impedance vs. Frequency**

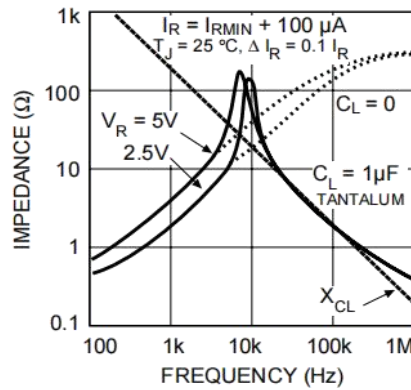

**Output Impedance vs. Frequency**

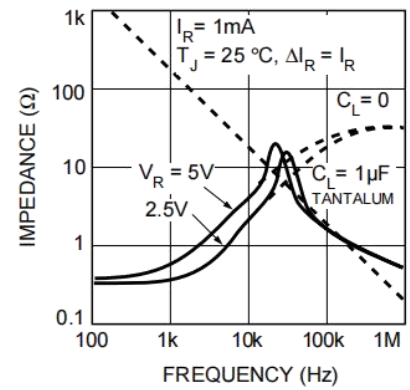

**Reverse Characteristics and Minimum Operating Current**

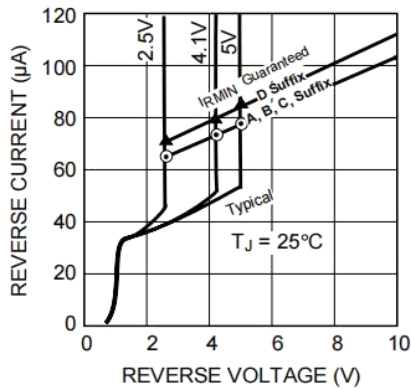

**Noise Voltage vs. Frequency**

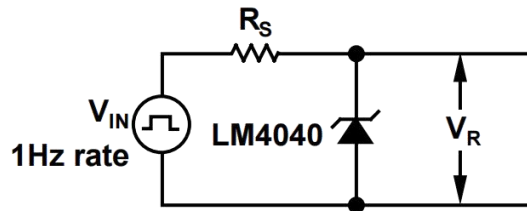
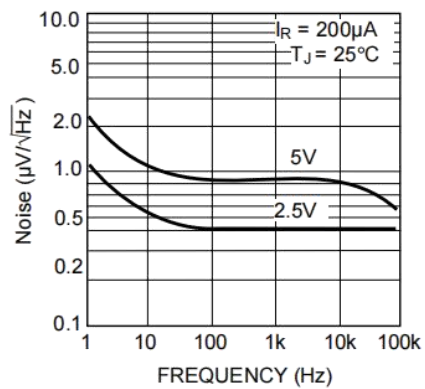

**Test Circuit**

**LM4040-2.5 R<sub>S</sub> = 30k**

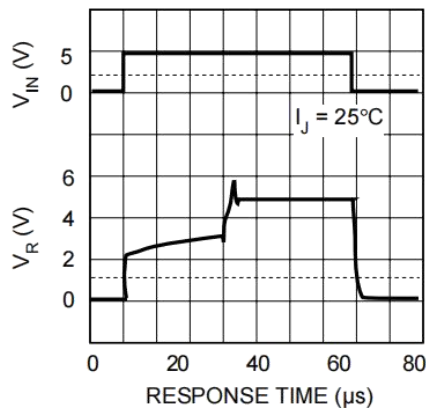

**LM4040-5.0 R<sub>S</sub> = 30k**

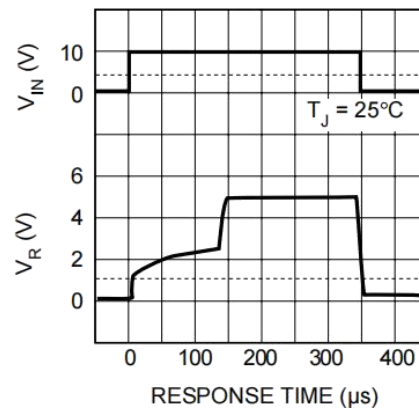

## LM4041-1.2 Electrical Characteristics

**Boldface** limits apply for  $T_A = T_J = T_{MIN}$  to  $T_{MAX}$ ; all other limits  $T_A = T_J = 25^\circ\text{C}$ . The grades A, B, C, D, and E designate initial Reverse Breakdown Voltage tolerance of  $\pm 0.1\%$ ,  $\pm 0.2\%$ ,  $\pm 0.5\%$ ,  $\pm 1.0\%$ , and  $\pm 2.0\%$  respectively.

Symbol	Parameter	Conditions	Typical (Note4)	LM4041AIM3 Limits (Note5)	LM4041BIM3 Limits (Note5)	LM4041CIM3 Limits (Note5)	Units (Limit)
$V_R$	Reverse Breakdown Voltage	$I_R = 100\mu\text{A}$	1.225				V
	Reverse Breakdown Voltage Tolerance	$I_R = 100\mu\text{A}$		$\pm 1.9$ <b><math>\pm 9.2</math></b>	$\pm 2.4$ <b><math>\pm 10.4</math></b>	$\pm 6$ <b><math>\pm 14</math></b>	mV (max) mV (max)
$I_{RMIN}$	Minimum Operating Current		45	60 <b>65</b>	60 <b>65</b>	60 <b>65</b>	$\mu\text{A}$ $\mu\text{A}$ (max) $\mu\text{A}$ (max)
$\Delta V_R/\Delta T$	Average Reverse Breakdown Voltage Temperature Coefficient	$I_R = 10\text{mA}$ $I_R = 1\text{mA}$ $I_R = 100\mu\text{A}$	$\pm 20$ $\pm 15$ $\pm 15$	<b><math>\pm 100</math></b>	<b><math>\pm 100</math></b>	<b><math>\pm 100</math></b>	ppm/ $^\circ\text{C}$ ppm/ $^\circ\text{C}$ (max) ppm/ $^\circ\text{C}$ (max)
$\Delta V_R/\Delta I_R$	Reverse Breakdown Voltage Change with Operating Current Change	$I_{RMIN} \leq I_R 1\text{mA}$	0.7	1.5 <b>2.0</b>	1.5 <b>2.0</b>	1.5 <b>2.0</b>	mV mV (max) mV (max)
		$1\text{mA} \leq I_R 15\text{mA}$	4.0	6.0 <b>8.0</b>	6.0 <b>8.0</b>	6.0 <b>8.0</b>	mV mV (max) mV (max)
$Z_R$	Reverse Dynamic Impedance	$I_R = 1\text{mA}$ , $f = 120\text{Hz}$ $I_{AC} = 0.1 I_R$	0.5	1.5	1.5	1.5	$\Omega$ $\Omega$ (max)
$e_N$	Wideband Noise	$I_R = 100\mu\text{A}$ $10\text{Hz} \leq f \leq 10\text{kHz}$	20				$\mu\text{V}_{RMS}$
$\Delta V_R$	Reverse Breakdown Voltage Long Term Stability	$t = 1000\text{hrs}$ $T = 25^\circ\text{C} \pm 0.1^\circ\text{C}$ $I_R = 100\mu\text{A}$	120				ppm

Symbol	Parameter	Conditions	Typical (Note 4)	LM4041DIM3 Limits (Note 5)	LM4041EIM3 Limits (Note 5)	Units (Limits)
$V_R$	Reverse Breakdown Voltage	$I_R = 100\mu\text{A}$	1.225			V
	Reverse Breakdown Voltage Tolerance	$I_R = 100\mu\text{A}$		$\pm 14$ <b><math>\pm 24</math></b>	$\pm 25$ <b><math>\pm 36</math></b>	mV (max) mV (max)
$I_{RMIN}$	Minimum Operating Current		45	65 <b>70</b>	65 <b>70</b>	$\mu\text{A}$ $\mu\text{A}$ (max) $\mu\text{A}$ (max)
$\Delta V_R/\Delta T$	Average Reverse Breakdown Voltage Temperature Coefficient	$I_R = 10\text{mA}$ $I_R = 1\text{mA}$ $I_R = 100\mu\text{A}$	$\pm 20$ $\pm 15$ $\pm 15$	<b><math>\pm 150</math></b>	<b><math>\pm 150</math></b>	ppm/ $^\circ\text{C}$ ppm/ $^\circ\text{C}$ (max) ppm/ $^\circ\text{C}$ (max)
$\Delta V_R/\Delta I_R$	Reverse Breakdown Voltage Change with Operating Current Change	$I_{RMIN} \leq I_R 1\text{mA}$	0.3	2.0 <b>2.5</b>	2.0 <b>2.5</b>	mV mV (max) mV (max)
		$1\text{mA} \leq I_R 15\text{mA}$	2.5	8.0 <b>12.0</b>	8.0 <b>12.0</b>	mV mV (max) mV (max)
$Z_R$	Reverse Dynamic Impedance	$I_R = 1\text{mA}$ , $f = 120\text{Hz}$ $I_{AC} = 0.1 I_R$	0.3	2.0	2.0	$\Omega$ $\Omega$ (max)
$e_N$	Wideband Noise	$I_R = 100\mu\text{A}$ $10\text{Hz} \leq f \leq 10\text{kHz}$	35			$\mu\text{V}_{RMS}$
$\Delta V_R$	Reverse Breakdown Voltage Long Term Stability	$t = 1000\text{hrs}$ $T = 25^\circ\text{C} \pm 0.1^\circ\text{C}$ $I_R = 100\mu\text{A}$	120			ppm

**LM4041-Adjustable Electrical Characteristics**

**Boldface** limits apply for  $T_A = T_J = T_{MIN}$  to  $T_{MAX}$ ; all other limits  $T_J = 25^\circ\text{C}$  unless otherwise specified (SOT-23, see Note 7),  $I_{RMIN} \leq I_R < 12\text{mA}$ ,  $V_{REF} \leq V_{OUT} \leq 10\text{V}$ . The grades C and D designate initial Reverse Breakdown Voltage tolerance of  $\pm 0.5\%$  and  $\pm 1\%$ , respectively for  $V_{OUT} = 5\text{V}$ .

Symbol	Parameter	Conditions	Typical (Note 4)	LM4041CIM3 Limits (Note 5)	LM4041DIM3 Limits (Note 5)	Units(Limit)
$V_{REF}$	Reference Breakdown Voltage	$I_R = 100\mu\text{A}$ $V_{OUT} = 5\text{V}$	1.233			V
	Reference Breakdown Voltage Tolerance (Note 8)	$I_R = 100\mu\text{A}$		$\pm 6.2$ <b><math>\pm 14</math></b>	$\pm 12$ <b><math>\pm 24</math></b>	mV (max) mV (max)
$I_{RMIN}$	Minimum Operating Current		45	60 <b>65</b>	65 <b>70</b>	$\mu\text{A}$ $\mu\text{A}$ (max) $\mu\text{A}$ (max)
		Reference Voltage Change with Operating Current Change	$I_{RMIN} \leq I_R 1\text{mA}$ SOT-23: $V_{OUT} \geq 1.6\text{V}$ (Note 7)	0.7	1.5 <b>2.0</b>	2.0 <b>2.5</b>
	$1\text{mA} \leq I_R 15\text{mA}$ SOT-23: $V_{OUT} \geq 1.6\text{V}$ (Note 7)		2	4 <b>6</b>	6 <b>8</b>	mV mV (max) mV (max)
$\frac{\Delta V_{REF}}{\Delta V_O}$	Reference Voltage Change with Output Voltage Change	$I_R = 1\text{mA}$	-1.3	-2.0 <b>-2.5</b>	-2.5 <b>-3.0</b>	mV/V mV/V(max) mV/V (max)
$I_{FB}$	Feedback Current		60	100 <b>120</b>	150 <b>200</b>	nA nA (max) nA (max)
$\frac{\Delta V_{REF}}{\Delta T_O}$	Average Reference Voltage Temperature Coefficient (Note 8)	$V_{OUT} = 5\text{V}$	20	<b><math>\pm 100</math></b>	<b><math>\pm 150</math></b>	ppm/ $^\circ\text{C}$ ppm/ $^\circ\text{C}$ (max) ppm/ $^\circ\text{C}$ (max)
		$I_R = 10\text{m}$	15			
		$I_{R} = 1\text{mA}$ $I_R = 100\mu\text{A}$	15			
$Z_{OUT}$	Dynamic Output Impedance	$I_R = 1\text{mA}$ , $f = 120\text{Hz}$				$\Omega$
		$I_{AC} = 0.1 I_R$ $V_{OUT} = V_{REF}$ $V_{OUT} = 10\text{V}$	0.3 2			$\Omega$ (max)
$e_N$	Wideband Noise	$I_R = 100\mu\text{A}$ $10\text{Hz} \leq f \leq 10\text{kHz}$	20			$\mu\text{V}_{RMS}$
$\Delta V_{REF}$	Reference Voltage Long Term Stability	$t = 1000\text{hrs}$ $T = 25^\circ\text{C} \pm 0.1^\circ\text{C}$ $I_R = 100\mu\text{A}$	120			ppm



## LM4040 and LM4041 Electrical Characteristic Notes

1. Absolute Maximum Ratings indicate limits beyond which damage to the device may occur. Operating Ratings indicate conditions for which the device is functional, but do not guarantee specific performance limits. For guaranteed specification and test conditions, see the Electrical Characteristics. The guaranteed specifications apply only for the test conditions listed. Some performance characteristics may degrade when the device is not operated under the listed test conditions.
2. The maximum power dissipation must be derated at elevated temperatures and is dictated by  $T_{JMAX}$  (maximum junction temperature),  $\theta_{JA}$  (junction to ambient thermal resistance), and  $T_A$  (ambient temperature). The maximum allowable power dissipation at any temperature is  $PD_{MAX} = (T_{JMAX} - T_A)/\theta_{JA}$  or the number given in the Absolute Maximum Ratings, whichever is lower. For the LM4040 and LM4041,  $T_{JMAX} = 125^\circ\text{C}$ , and the typical thermal resistance ( $\theta_{JA}$ ), when board mounted, is  $326^\circ\text{C}/\text{W}$  for the SOT-23 package.
3. The human body model is a 100pF capacitor discharged through a 1.5k $\Omega$  resistor into each pin. The machine model is a 200pF capacitor discharged directly into each pin.
4. Typicals are at  $T_J = 25^\circ\text{C}$  and represent most likely parametric norm.
5. Limits are 100% production tested at  $25^\circ\text{C}$ . Limits over temperature are guaranteed through correlation using Statistical Quality Control (SQL) methods.
6. The boldface (over temperature limit for Reverse Breakdown Voltage Tolerance is defined as the room temperature Reverse Breakdown Voltage Tolerance  $[(\Delta V_R/\Delta T)(65^\circ\text{C})(V_R)]$ .  $\Delta V_R/\Delta T$  is the  $V_R$  temperature coefficient,  $65^\circ\text{C}$  is the temperature range from  $-40^\circ\text{C}$  to the reference point of  $25^\circ\text{C}$ , and  $V_R$  is the reverse breakdown voltage. The total over temperature tolerance for the different grades follows:
  - A. grade:  $\pm 0.75\% = \pm 0.1\%$  100ppm/ $^\circ\text{C}$   $65^\circ\text{C}$
  - B. grade:  $\pm 0.85\% = \pm 0.2\%$  100ppm/ $^\circ\text{C}$   $65^\circ\text{C}$
  - C. grade:  $\pm 1.15\% = \pm 0.5\%$  100ppm/ $^\circ\text{C}$   $65^\circ\text{C}$
  - D. grade:  $\pm 1.98\% = \pm 1.0\%$  150ppm/ $^\circ\text{C}$   $65^\circ\text{C}$
  - E. grade:  $\pm 2.98\% = \pm 2.0\%$  150ppm/ $^\circ\text{C}$   $65^\circ\text{C}$
  - F. Therefore, as an example: The A-grade LM4040-2.5 has an over temperature Reverse Breakdown Voltage tolerance of  $\pm 2.5 \times 0.75\% = \pm 19\text{mV}$ .
7. When  $V_{OUT} \leq 1.6\text{V}$ , the LM4041-ADJ must operate at reduced  $I_R$ . This is caused by the series resistance of the die attach between the die (-) output and the package (-) output pin. See the Output Saturation curve in the Typical Performance Characteristics section.
8. Reference voltage and temperature coefficient will change with output voltage. See Typical Performance Characteristics curves.

## LM4041-1.2 Typical Characteristics

Temperature Drift for Different Average Temperature Coefficient

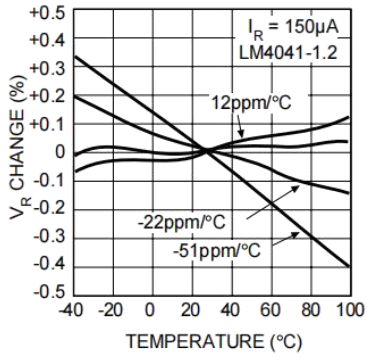

Output Impedance vs. Frequency

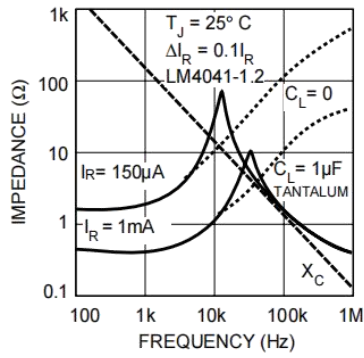

Voltage Impedance

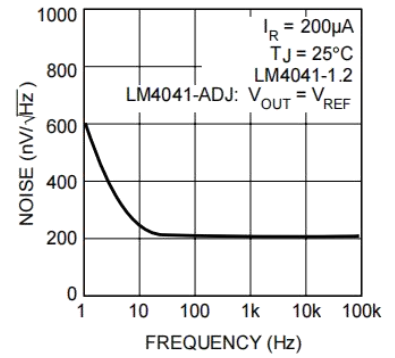

Reverse Characteristics and Minimum Operating Current

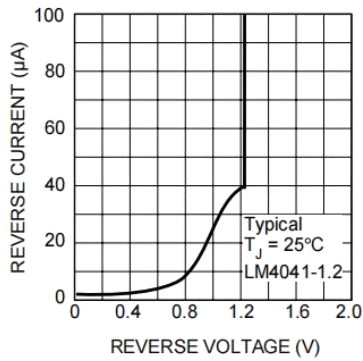

Reverse Characteristics and Minimum Operating Current

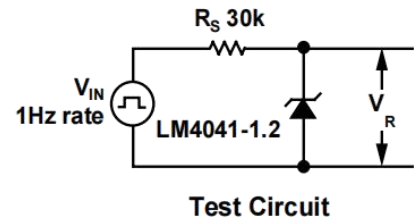
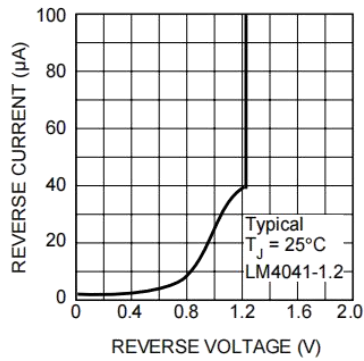

**LM4041-ADJ Typical Characteristics**

**Reference Voltage vs. Output Voltage and Temperature**

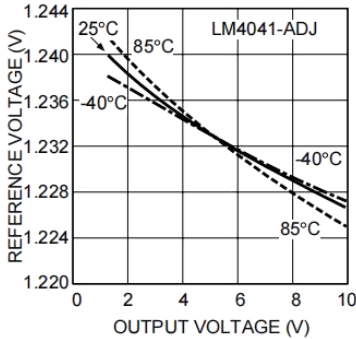

**Reference Voltage vs. Temperature and Output Voltage**

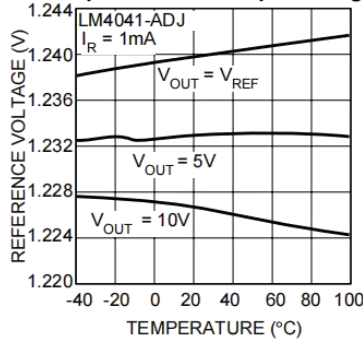

**Feedback Current vs. Output Voltage and Temperature**

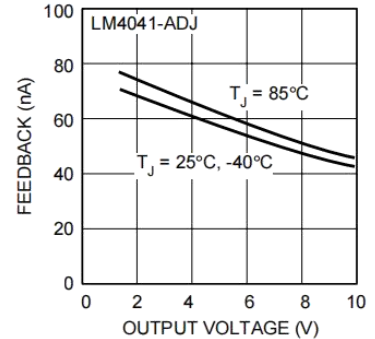

**Output Saturation**

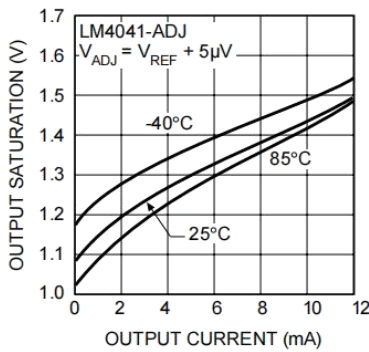

**Output Impedance vs. Frequency \***

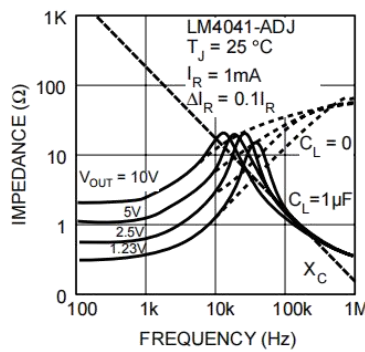

**Output Impedance vs. Frequency \***

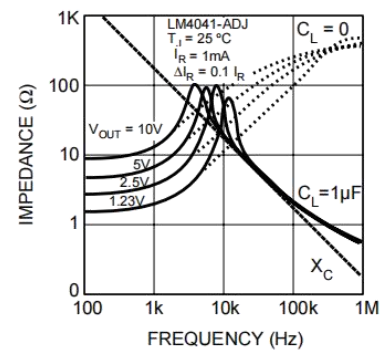

**Reverse Characteristics †**

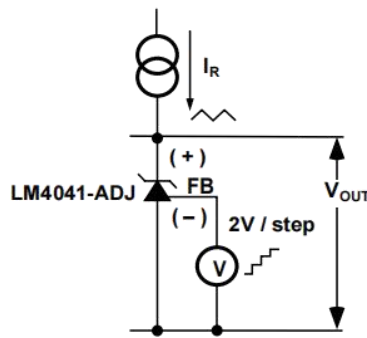
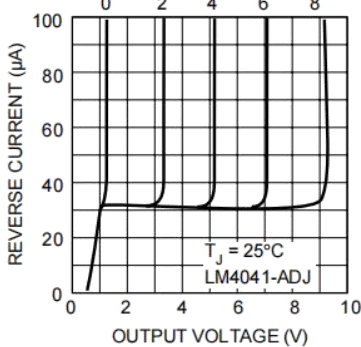

**† Reverse Characteristics Test Circuit**

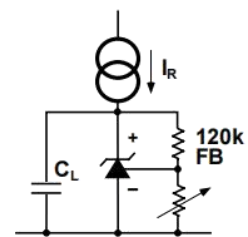

**\* Output Impedance vs. Freq. Test Circuit**

**Large Signal Response ‡**

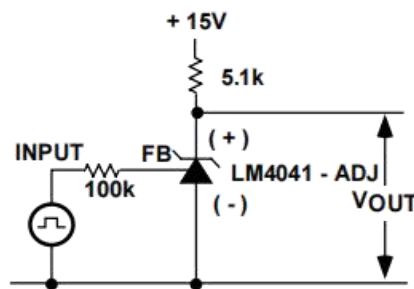
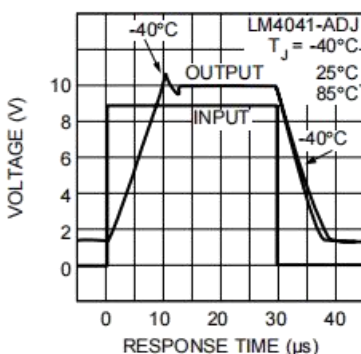

**‡ Large Signal Response Test Circuit**

## Applications Information

The LM4040 and LM4041 have been designed for stable operation without the need of an external capacitor connected between the (+) and (–) pins. If a bypass capacitor is used, the references remain stable.

### Schottky Diode

LM4040-x.x and LM4041-1.2 in the SOT-23 package have a parasitic Schottky diode between pin 2 (–) and pin 3 (die attach interface connect). Pin 3 of the SOT-23 package must float or be connected to pin 1. LM4041-ADJs use pin 3 as the (–) output.

### Conventional Shunt Regulator

In a conventional shunt regulator application (see Figure 1), an external series resistor ( $R_S$ ) is connected between the supply voltage and the LM4040-x.x or LM4041-1.2 reference.  $R_S$  determines the current that flows through the load ( $I_L$ ) and the reference ( $I_Q$ ). Since load current and supply voltage may vary,  $R_S$  should be small enough to supply at least the minimum acceptable  $I_Q$  to the reference even when the supply voltage is at its minimum and the load current is at its maximum value. When the supply voltage is at its maximum and  $I_L$  is at its minimum,  $R_S$  should be large enough so that the current flowing through the LM4040-x.x is less than 15mA, and the current flowing through the LM4041-1.2 or LM4041-ADJ is less than 12mA.

$R_S$  is determined by the supply voltage ( $V_S$ ), the load and operating current, ( $I_L$  and  $I_Q$ ), and the reference's reverse breakdown voltage ( $V_R$ ).

$$R_S = (V_S - V_R) / (I_L + I_Q)$$

### Adjustable Regulator

The LM4041-ADJ's output voltage can be adjusted to any value in the range of 1.24V through 10V. It is a function of the internal reference voltage ( $V_{REF}$ ) and the ratio of the external feedback resistors as shown in Figure 2. The output is found using the equation

$$(1) \quad V_O = V_{REF}' [ (R_2/R_1) + 1 ]$$

where  $V_O$  is the desired output voltage. The actual value of the internal  $V_{REF}$  is a function of  $V_O$ . The "corrected"  $V_{REF}'$  is determined by

$$(2) \quad V_{REF}' = V_O (\Delta V_{REF} / \Delta V_O) + V_Y$$

where  $V_O$  is the desired output voltage.  $\Delta V_{REF} / \Delta V_O$  is found in the Electrical Characteristics and is typically  $-1.3\text{mV/V}$  and  $V_Y$  is equal to 1.233V. Replace the value of  $V_{REF}'$  in equation (1) with the value found using equation (2).

Note that actual output voltage can deviate from that predicted using the typical  $\Delta V_{REF} / \Delta V_O$  in equation (2); for C- grade parts, the worst-case  $\Delta V_{REF} / \Delta V_O$  is  $-2.5\text{mV/V}$  and  $V_Y = 1.248\text{V}$ .

The following example shows the difference in output voltage resulting from the typical and worst case values of  $\Delta V_{REF} / \Delta V_O$ :

Let  $V_O = +9\text{V}$ . Using the typical values of  $\Delta V_{REF} / \Delta V_O$ ,  $V_{REF}$  is 1.223V. Choosing a value of  $R_1 = 10\text{k}\Omega$ ,  $R_2 = 63.272\text{k}\Omega$ . Using the worst case  $\Delta V_{REF} / \Delta V_O$  for the C-grade and D-grade parts, the output voltage is actually 8.965V and 8.946V respectively. This results in possible errors as large as 0.39% for the C-grade parts and 0.59% for the D-grade parts. Once again, resistor values found using the typical value of  $\Delta V_{REF} / \Delta V_O$  will work in most cases, requiring no further adjustment.

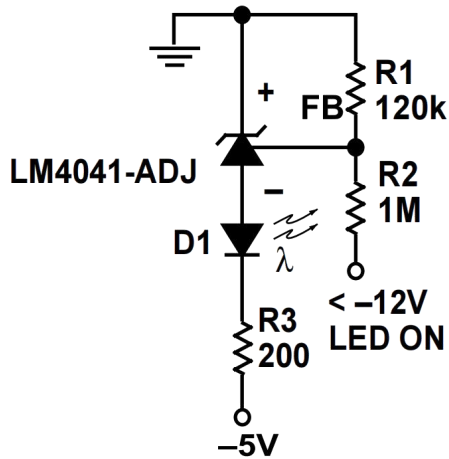

Figure 3. Voltage Level Detector

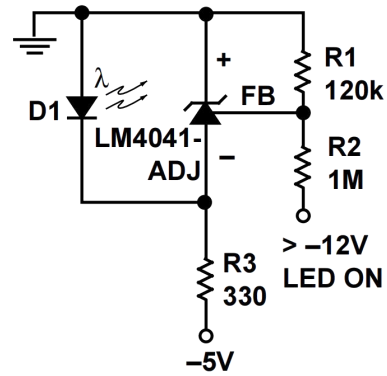

Figure 4. Voltage Level Detector

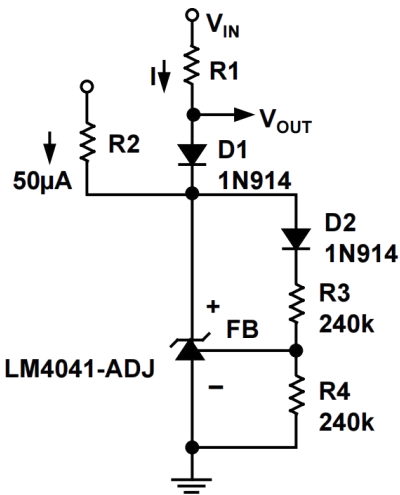

Figure 5. Fast Positive Clamp  $2.4V + \Delta V_{D1}$

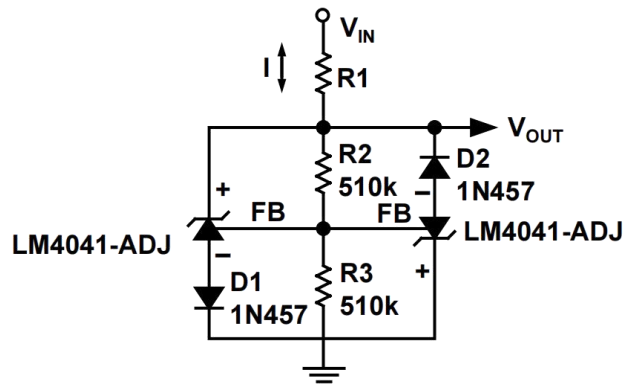

Figure 6. Bidirectional Clamp +2.4V

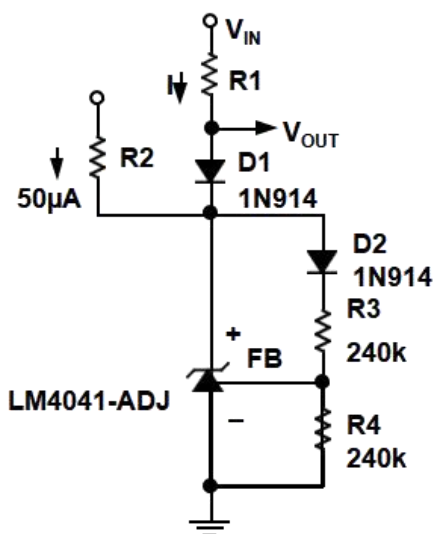

Figure 7. Bidirectional Adjustable Clamp  $\pm 18V$  to  $\pm 2.4V$

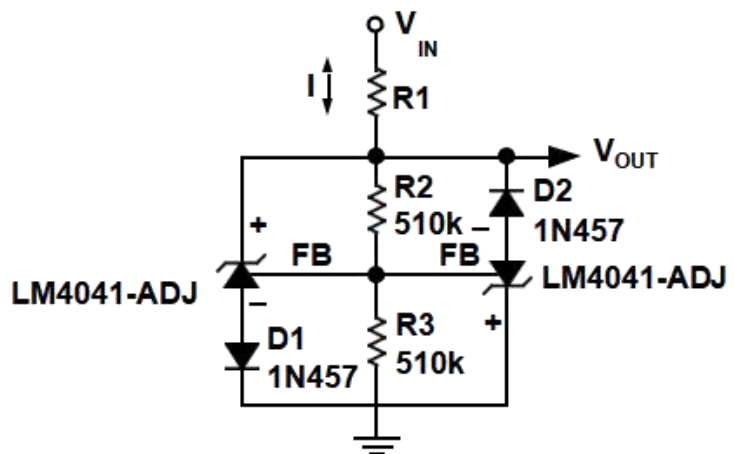

Figure 8. Bidirectional Adjustable Clamp  $\pm 2.4$  to  $\pm 6V$

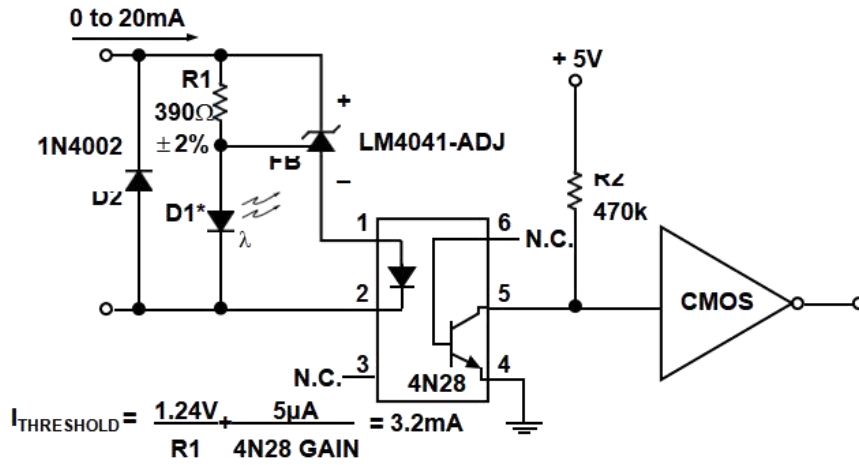

Figure 9. Floating Current Detector

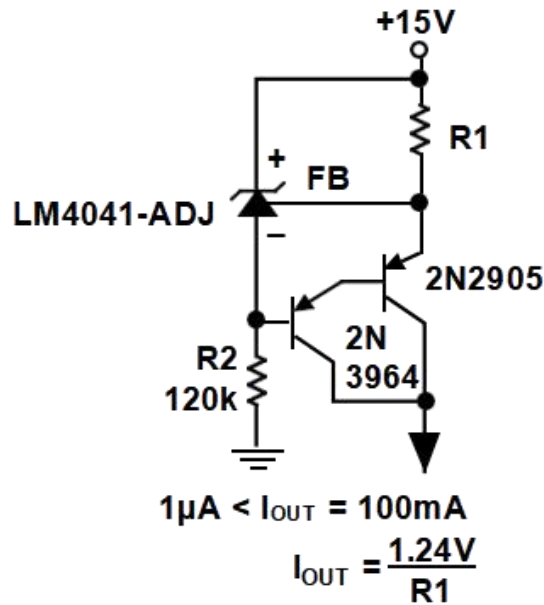

Figure 10. Current Source

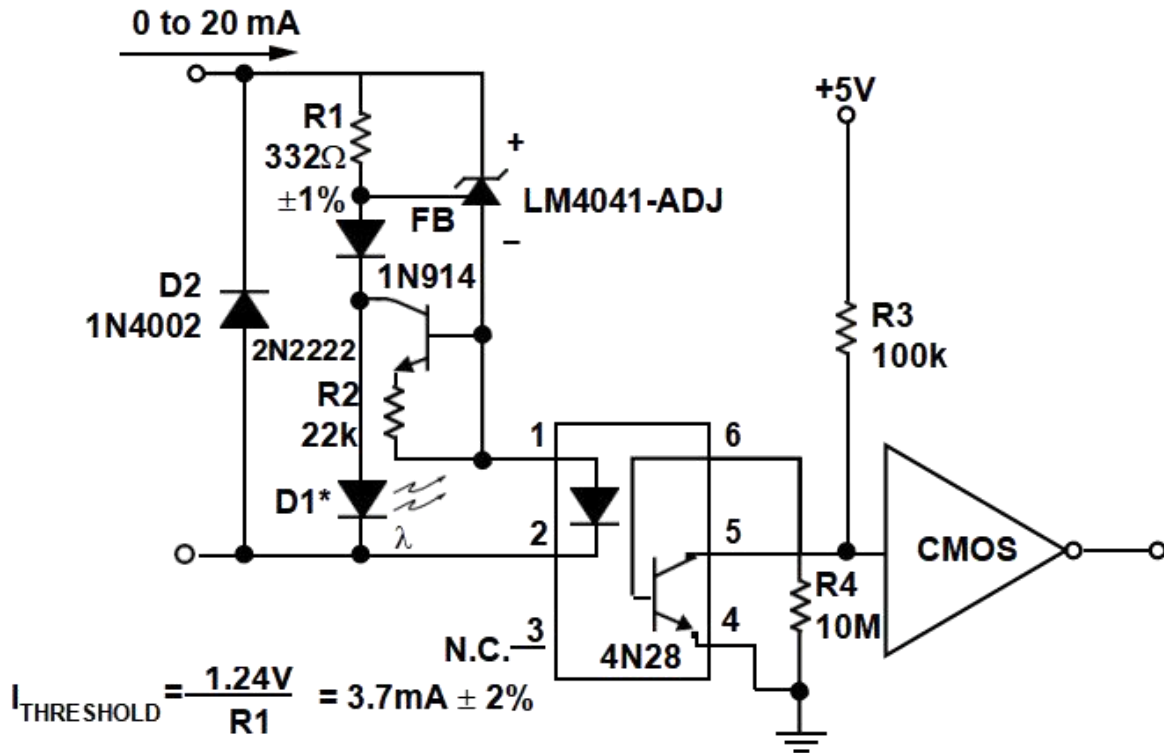
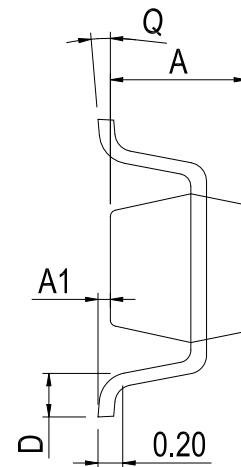
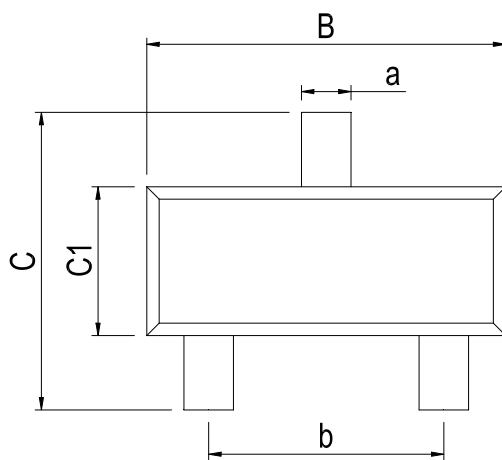

Figure 11. Precision Floating Current Detector

\* D1 can be any LED,  $V_F = 1.5\text{V}$  to  $2.2\text{V}$  at  $3\text{mA}$ . D1 may act as an indicator. D1 will be on if  $I_{\text{THRESHOLD}}$  falls below the threshold current, except with  $I = 0$ .

**Package Information**

SOT-23



Dimensions In Millimeters(SOT-23)									
Symbol:	A	A1	B	C	C1	D	Q	a	b
Min:	0.90	0.00	2.80	2.25	1.20	0.13	0°	0.30	1.90 BSC
Max:	1.05	0.15	3.00	2.55	1.40	0.41	8°	0.50	



## Revision History

DATE	REVISION	PAGE
2014-3-4	New	1-19
2023-9-14	Add annotation for Maximum Ratings.	3
2024-11-6	The LM4040 model has increased by 2.048V, 3.000V, 8.192V, and 10V. Update Lead Temperature	1-14

**IMPORTANT STATEMENT:**

Huaguan Semiconductor reserves the right to change its products and services without notice. Before ordering, the customer shall obtain the latest relevant information and verify whether the information is up to date and complete. Huaguan Semiconductor does not assume any responsibility or obligation for the altered documents.

Customers are responsible for complying with safety standards and taking safety measures when using Huaguan Semiconductor products for system design and machine manufacturing. You will bear all the following responsibilities: Select the appropriate Huaguan Semiconductor products for your application; Design, validate and test your application; Ensure that your application meets the appropriate standards and any other safety, security or other requirements. To avoid the occurrence of potential risks that may lead to personal injury or property loss.

Huaguan Semiconductor products have not been approved for applications in life support, military, aerospace and other fields, and Huaguan Semiconductor will not bear the consequences caused by the application of products in these fields. All problems, responsibilities and losses arising from the user's use beyond the applicable area of the product shall be borne by the user and have nothing to do with Huaguan Semiconductor, and the user shall not claim any compensation liability against Huaguan Semiconductor by the terms of this Agreement.

The technical and reliability data (including data sheets), design resources (including reference designs), application or other design suggestions, network tools, safety information and other resources provided for the performance of semiconductor products produced by Huaguan Semiconductor are not guaranteed to be free from defects and no warranty, express or implied, is made. The use of testing and other quality control technologies is limited to the quality assurance scope of Huaguan Semiconductor. Not all parameters of each device need to be tested.

The documentation of Huaguan Semiconductor authorizes you to use these resources only for developing the application of the product described in this document. You have no right to use any other Huaguan Semiconductor intellectual property rights or any third party intellectual property rights. It is strictly forbidden to make other copies or displays of these resources. You should fully compensate Huaguan Semiconductor and its agents for any claims, damages, costs, losses and debts caused by the use of these resources. Huaguan Semiconductor accepts no liability for any loss or damage caused by infringement.

单击下面可查看定价，库存，交付和生命周期等信息

[>>HGSEMI\(华冠\)](#)