

## CMOS Dual Complementary Pair Plus Inverter

### Features

- High-Voltage Type (20V Rating)
- Standardized Symmetrical Output Characteristics
- Medium Speed Operation
  - $t_{PHL}$ ,  $t_{PLH}$  = 30 ns (typ) at 10V
- 100% Tested for Maximum Quiescent Current at 20V
- Meets All Requirements of JEDEC Tentative Standards No. 13B, "Standard Specifications for Description of "B" Series CMOS Devices"
- Maximum Input Current of  $1\mu\text{A}$  at 18V Over Full Package-Temperature Range; 100nA at 18V and  $+25^\circ\text{C}$

### Applications

- Extremely High-Input Impedance Amplifiers
- Shapers
- Inverters
- Threshold Detector
- Linear Amplifiers
- Crystal Oscillators

### Description

CD4007B types are comprised of three n-channel and three p-channel enhancement-type MOS transistors. The transistor elements are accessible through the package terminals to provide a convenient means for constructing the various typical circuits as shown in Figure 2.

More complex functions are possible using multiple packages. Numbers shown in parentheses indicate terminals that are connected together to form the various configurations listed.

The CD4007B is supplied in these 14 lead outline packages:

Braze Seal DIP	H4Q
Frit Seal DIP	H1B
Ceramic Flatpack	H3W

### Pinout

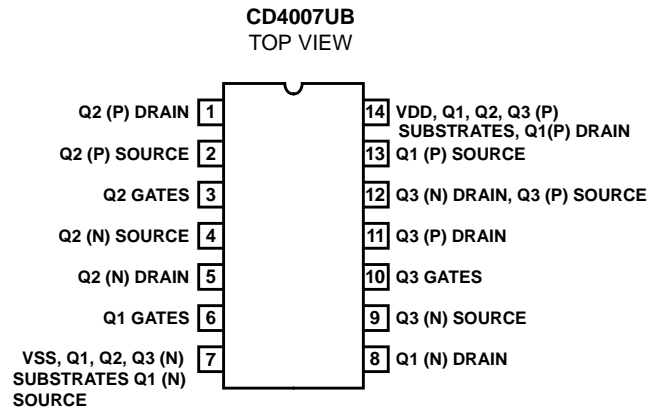

### Functional Diagram

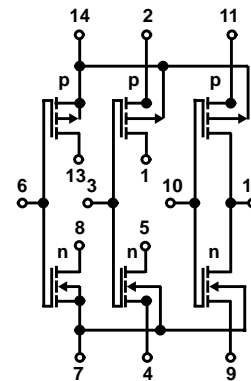

TERMINAL NO. 14 - VDD

TERMINAL NO. 7 - VSS

**Absolute Maximum Ratings**

DC Supply Voltage Range, (VDD) ..... -0.5V to +20V  
(Voltage Referenced to VSS Terminals)  
Input Voltage Range, All Inputs ..... -0.5V to VDD +0.5V  
DC Input Current, Any One Input ..... ±10mA  
Operating Temperature Range ..... -55°C to +125°C  
Package Types D, F, K, H  
Storage Temperature Range (TSTG) ..... -65°C to +150°C  
Lead Temperature (During Soldering) ..... +265°C  
At Distance 1/16 ± 1/32 Inch (1.59mm ± 0.79mm) from case for  
10s Maximum

**Reliability Information**

Thermal Resistance .....  $\theta_{ja}$   $\theta_{jc}$   
Ceramic DIP and FRIT Package ..... 80°C/W 20°C/W  
Flatpack Package ..... 70°C/W 20°C/W  
Maximum Package Power Dissipation (PD) at +125°C  
For  $T_A = -55^\circ\text{C}$  to +100°C (Package Type D, F, K) ..... 500mW  
For  $T_A = +100^\circ\text{C}$  to +125°C (Package Type D, F, K) ..... Derate  
Linearity at 12mW/°C to 200mW  
Device Dissipation per Output Transistor ..... 100mW  
For  $T_A =$  Full Package Temperature Range (All Package Types)  
Junction Temperature ..... +175°C

**TABLE 1. DC ELECTRICAL PERFORMANCE CHARACTERISTICS**

PARAMETER	SYMBOL	CONDITIONS (NOTE 1)		GROUP A SUBGROUPS	TEMPERATURE	LIMITS		UNITS
						MIN	MAX	
Supply Current	IDD	VDD = 20V, VIN = VDD or GND		1	+25°C	-	0.5	µA
				2	+125°C	-	50	µA
		VDD = 18V, VIN = VDD or GND		3	-55°C	-	0.5	µA
Input Leakage Current	IIL	VIN = VDD or GND	VDD = 20	1	+25°C	-100	-	nA
				2	+125°C	-1000	-	nA
			VDD = 18V	3	-55°C	-100	-	nA
Input Leakage Current	IIH	VIN = VDD or GND	VDD = 20	1	+25°C	-	100	nA
				2	+125°C	-	1000	nA
			VDD = 18V	3	-55°C	-	100	nA
Output Voltage	VOL15	VDD = 15V, No Load		1, 2, 3	+25°C, +125°C, -55°C	-	50	mV
Output Voltage	VOH15	VDD = 15V, No Load (Note 3)		1, 2, 3	+25°C, +125°C, -55°C	14.95	-	V
Output Current (Sink)	IOL5	VDD = 5V, VOUT = 0.4V		1	+25°C	0.53	-	mA
Output Current (Sink)	IOL10	VDD = 10V, VOUT = 0.5V		1	+25°C	1.4	-	mA
Output Current (Sink)	IOL15	VDD = 15V, VOUT = 1.5V		1	+25°C	3.5	-	mA
Output Current (Source)	IOH5A	VDD = 5V, VOUT = 4.6V		1	+25°C	-	-0.53	mA
Output Current (Source)	IOH5B	VDD = 5V, VOUT = 2.5V		1	+25°C	-	-1.8	mA
Output Current (Source)	IOH10	VDD = 10V, VOUT = 9.5V		1	+25°C	-	-1.4	mA
Output Current (Source)	IOH15	VDD = 15V, VOUT = 13.5V		1	+25°C	-	-3.5	mA
N Threshold Voltage	VNTH	VDD = 10V, ISS = -10µA		1	+25°C	-2.8	-0.7	V
P Threshold Voltage	VPTH	VSS = 0V, IDD = 10µA		1	+25°C	0.7	2.8	V
Functional	F	VDD = 2.8V, VIN = VDD or GND		7	+25°C	VOH > VDD/2	VOL < VDD/2	V
		VDD = 20V, VIN = VDD or GND		7	+25°C			
		VDD = 18V, VIN = VDD or GND		8A	+125°C			
		VDD = 3V, VIN = VDD or GND		8B	-55°C			
Input Voltage Low (Note 2)	VIL	VDD = 5V, VOH > 4.5V, VOL < 0.5V		1, 2, 3	+25°C, +125°C, -55°C	-	1.0	V
Input Voltage High (Note 2)	VIH	VDD = 5V, VOH > 4.5V, VOL < 0.5V		1, 2, 3	+25°C, +125°C, -55°C	4.0	-	V
Input Voltage Low (Note 2)	VIL	VDD = 15V, VOH > 13.5V, VOL < 1.5V		1, 2, 3	+25°C, +125°C, -55°C	-	2.5	V
Input Voltage High (Note 2)	VIH	VDD = 15V, VOH > 13.5V, VOL < 1.5V		1, 2, 3	+25°C, +125°C, -55°C	12.5	-	V

NOTES: 1. All voltages referenced to device GND, 100% testing being implemented. 3. For accuracy, voltage is measured differentially to VDD. Limit is 0.050V max.  
2. Go/No Go test with limits applied to inputs

**TABLE 2. AC ELECTRICAL PERFORMANCE CHARACTERISTICS**

PARAMETER	SYMBOL	CONDITIONS (NOTE 1, 2)	GROUP A SUBGROUPS	TEMPERATURE	LIMITS		UNITS
					MIN	MAX	
Propagation Delay	TPHL TPLH	VDD = 5V, VIN = VDD or GND	9	+25°C	-	110	ns
			10, 11	+125°C, -55°C	-	149	ns
Transition Time	TTHL TTLH	VDD = 5V, VIN = VDD or GND	9	+25°C	-	200	ns
			10, 11	+125°C, -55°C	-	270	ns

NOTES:

1. CL = 50pF, RL = 200K, Input TR, TF < 20ns.
2. 55°C and +125°C limits guaranteed, 100% testing being implemented.

**TABLE 3. ELECTRICAL PERFORMANCE CHARACTERISTICS**

PARAMETER	SYMBOL	CONDITIONS	NOTES	TEMPERATURE	LIMITS		UNITS
					MIN	MAX	
Supply Current	IDD	VDD = 5V, VIN = VDD or GND	1, 2	-55°C, +25°C	-	0.25	μA
				+125°C	-	7.5	μA
		VDD = 10V, VIN = VDD or GND	1, 2	-55°C, +25°C	-	0.5	μA
				+125°C	-	15	μA
		VDD = 15V, VIN = VDD or GND	1, 2	-55°C, +25°C	-	0.5	μA
+125°C	-			30	μA		
Output Voltage	VOL	VDD = 5V, No Load	1, 2	+25°C, +125°C, -55°C	-	50	mV
Output Voltage	VOL	VDD = 10V, No Load	1, 2	+25°C, +125°C, -55°C	-	50	mV
Output Voltage	VOH	VDD = 5V, No Load	1, 2	+25°C, +125°C, -55°C	4.95	-	V
Output Voltage	VOH	VDD = 10V, No Load	1, 2	+25°C, +125°C, -55°C	9.95	-	V
Output Current (Sink)	IOL5	VDD = 5V, VOUT = 0.4V	1, 2	+125°C	0.36	-	mA
				-55°C	0.64	-	mA
Output Current (Sink)	IOL10	VDD = 10V, VOUT = 0.5V	1, 2	+125°C	0.9	-	mA
				-55°C	1.6	-	mA
Output Current (Sink)	IOL15	VDD = 15V, VOUT = 1.5V	1, 2	+125°C	2.4	-	mA
				-55°C	4.2	-	mA
Output Current (Source)	IOH5A	VDD = 5V, VOUT = 4.6V	1, 2	+125°C	-	-0.36	mA
				-55°C	-	-0.64	mA
Output Current (Source)	IOH5B	VDD = 5V, VOUT = 2.5V	1, 2	+125°C	-	-1.15	mA
				-55°C	-	-2.0	mA
Output Current (Source)	IOH10	VDD = 10V, VOUT = 9.5V	1, 2	+125°C	-	-0.9	mA
				-55°C	-	-1.6	mA
Output Current (Source)	IOH15	VDD = 15V, VOUT = 13.5V	1, 2	+125°C	-	-2.4	mA
				-55°C	-	-4.2	mA
Input Voltage Low	VIL	VDD = 10V, VOH > 9V, VOL < 1V	1, 2	+25°C, +125°C, -55°C	-	2	V
Input Voltage High	VIH	VDD = 10V, VOH > 9V, VOL < 1V	1, 2	+25°C, +125°C, -55°C	8	-	V
Propagation Delay	TPHL TPLH	VDD = 10V	1, 2, 3	+25°C	-	60	ns
		VDD = 15V	1, 2, 3	+25°C	-	50	ns

**TABLE 3. ELECTRICAL PERFORMANCE CHARACTERISTICS (Continued)**

PARAMETER	SYMBOL	CONDITIONS	NOTES	TEMPERATURE	LIMITS		UNITS
					MIN	MAX	
Transition Time	TTHL TTLH	VDD = 10V	1, 2, 3	+25°C	-	100	ns
		VDD = 15V	1, 2, 3	+25°C	-	80	ns
Input Capacitance	CIN	Any Input	1, 2	+25°C	-	15.0	pF

NOTES:

- All voltages referenced to device GND.
- The parameters listed on Table 3 are controlled via design or process and are not directly tested. These parameters are characterized on initial design release and upon design changes which would affect these characteristics.
- CL = 50pF, RL = 200K, Input TR, TF < 20ns.

**TABLE 4. POST IRRADIATION ELECTRICAL PERFORMANCE CHARACTERISTICS**

PARAMETER	SYMBOL	CONDITIONS	NOTES	TEMPERATURE	LIMITS		UNITS
					MIN	MAX	
Supply Current	IDD	VDD = 20V, VIN = VDD or GND	1, 4	+25°C	-	2.5	μA
N Threshold Voltage	VNTH	VDD = 10V, ISS = -10μA	1, 4	+25°C	-2.8	-0.2	V
N Threshold Voltage Delta	ΔVNTH	VDD = 10V, ISS = -10μA	1, 4	+25°C	-	±1	V
P Threshold Voltage	VPTH	VSS = 0V, IDD = 10μA	1, 4	+25°C	0.2	2.8	V
P Threshold Voltage Delta	ΔVPTH	VSS = 0V, IDD = 10μA	1, 4	+25°C	-	±1	V
Functional	F	VDD = 18V, VIN = VDD or GND VDD = 3V, VIN = VDD or GND	1	+25°C	VOH > VDD/2	VOL < VDD/2	V
Propagation Delay Time	TPHL TPLH	VDD = 5V	1, 2, 3, 4	+25°C	-	1.35 x +25°C Limit	ns

- NOTES: 1. All voltages referenced to device GND. 2. CL = 50pF, RL = 200K, Input TR, TF < 20ns. 3. See Table 2 for +25°C limit. 4. Read and Record

**TABLE 5. BURN-IN AND LIFE TEST DELTA PARAMETERS +25°C**

PARAMETER	SYMBOL	DELTA LIMIT
Supply Current - SSI	IDD	±0.1μA
Output Current (Sink)	IOL5	± 20% x Pre-Test Reading
Output Current (Source)	IOH5A	± 20% x Pre-Test Reading

**TABLE 6. APPLICABLE SUBGROUPS**

CONFORMANCE GROUP	MIL-STD-883 METHOD	GROUP A SUBGROUPS	READ AND RECORD
Initial Test (Pre Burn-In)	100% 5004	1, 7, 9	IDD, IOL5, IOH5A
Interim Test 1 (Post Burn-In)	100% 5004	1, 7, 9	IDD, IOL5, IOH5A
Interim Test 2 (Post Burn-In)	100% 5004	1, 7, 9	IDD, IOL5, IOH5A
PDA (Note 1)	100% 5004	1, 7, 9, Deltas	
Interim Test 3 (Post Burn-In)	100% 5004	1, 7, 9	IDD, IOL5, IOH5A
PDA (Note 1)	100% 5004	1, 7, 9, Deltas	
Final Test	100% 5004	2, 3, 8A, 8B, 10, 11	
Group A	Sample 5005	1, 2, 3, 7, 8A, 8B, 9, 10, 11	
Group B	Subgroup B-5	Sample 5005	Subgroups 1, 2, 3, 9, 10, 11
	Subgroup B-6	Sample 5005	1, 7, 9

**TABLE 6. APPLICABLE SUBGROUPS (Continued)**

CONFORMANCE GROUP	MIL-STD-883 METHOD	GROUP A SUBGROUPS	READ AND RECORD
Group D	Sample 5005	1, 2, 3, 8A, 8B, 9	Subgroups 1, 2 3

NOTE: 1. 5% Parametric, 3% Functional; Cumulative for Static 1 and 2.

**TABLE 7. TOTAL DOSE IRRADIATION**

CONFORMANCE GROUPS	MIL-STD-883 METHOD	TEST		READ AND RECORD	
		PRE-IRRAD	POST-IRRAD	PRE-IRRAD	POST-IRRAD
Group E Subgroup 2	5005	1, 7, 9	Table 4	1, 9	Table 4

**TABLE 8. BURN-IN AND IRRADIATION TEST CONNECTIONS**

FUNCTION	OPEN	GROUND	VDD	9V ± 0.5V	OSCILLATOR	
					50kHz	25kHz
Static Burn-In 1 Note 1	1, 5, 8, 12, 13	3, 4, 6, 7, 9, 10	2, 11, 14			
Static Burn-In 2 Note 1	1, 5, 8, 12, 13	4, 7, 9	2, 3, 6, 10, 11, 14			
Dynamic Burn-In Note 1	-	4, 7, 9	2, 11, 14	1, 5, 8, 12, 13	3, 6, 10	-
Irradiation Note 2	1, 5, 8, 12, 13	4, 7, 9	2, 3, 6, 10, 11, 14			

NOTE:

- Each pin except VDD and GND will have a series resistor of 10K ±5%, VDD = 18V ±0.5V
- Each pin except VDD and GND will have a series resistor of 47K ±5%; Group E, Subgroup 2, sample size is 4 dice/wafer, 0 failures, VDD = 10V ±0.5V

**Schematic Diagram**

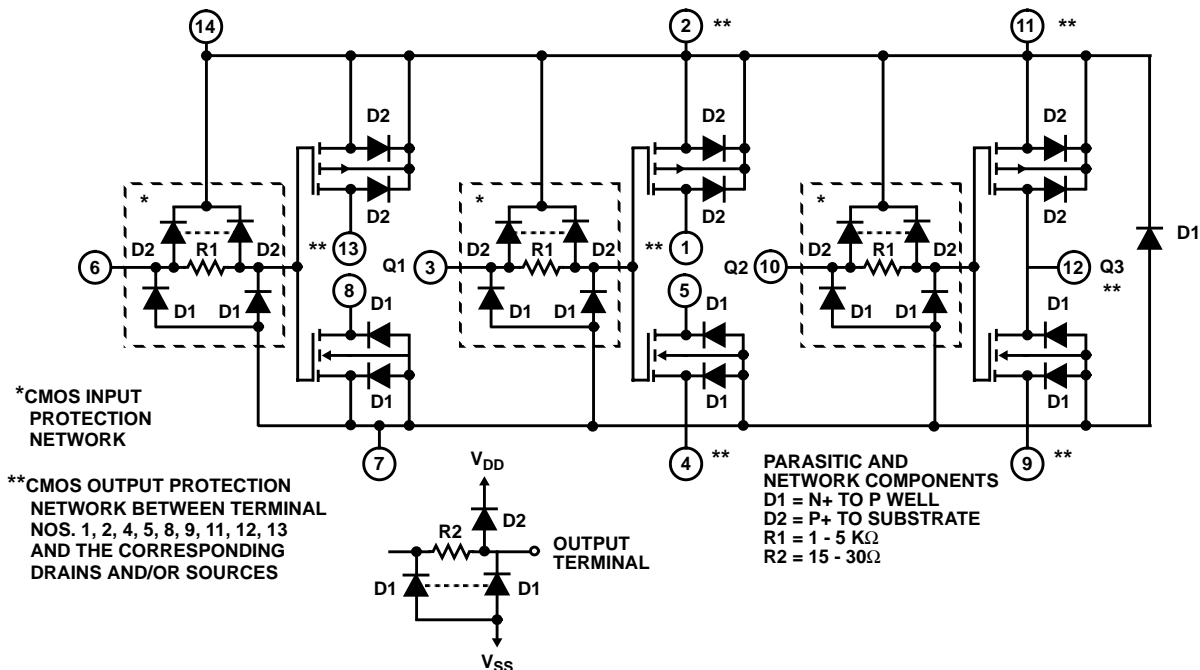

**FIGURE 1. DETAILED SCHEMATIC DIAGRAM OF CD4007UB SHOWING INPUT, OUTPUT, AND PARASITIC DIODES**

**Logic Circuits**

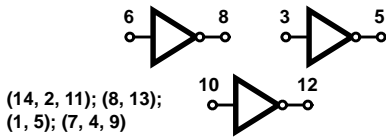

(14, 2, 11); (8, 13);  
(1, 5); (7, 4, 9)

**a) TRIPLE INVERTERS**



(13, 2); (1, 11);  
(12, 5, 8); (7, 4, 9)

**b) 3 - INPUT NOR GATE**



(1, 12, 13); (2, 14, 11);  
(4, 8); (5, 9)

**c) 3 - INPUT NAND GATE**

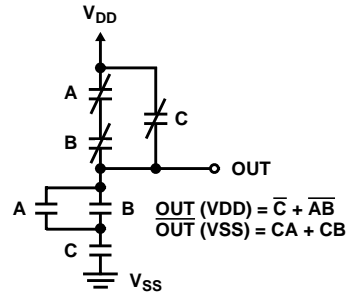
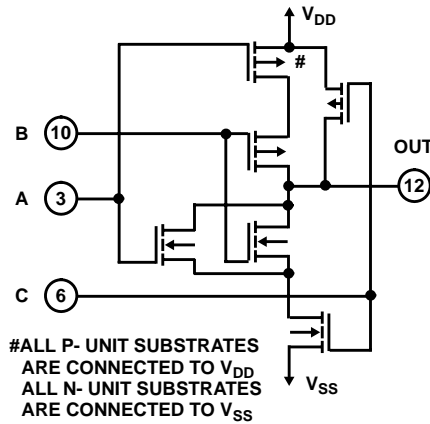

(13, 12, 5); (4, 9, 8);  
(14, 2); (1, 11)

**d) TREE (RELAY) LOGIC**

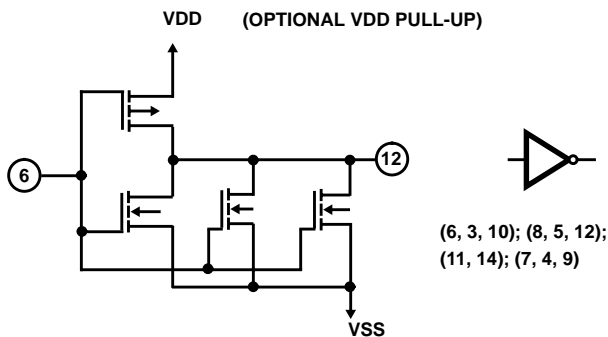

**e) HIGH SINK-CURRENT DRIVER**

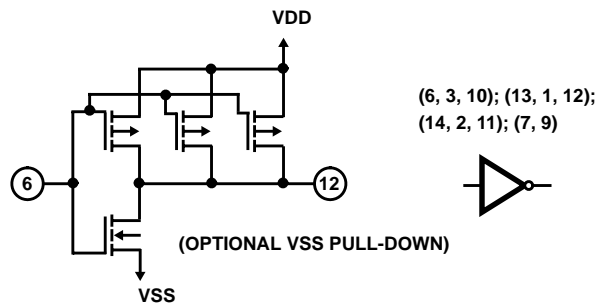

**f) HIGH SOURCE-CURRENT DRIVER**

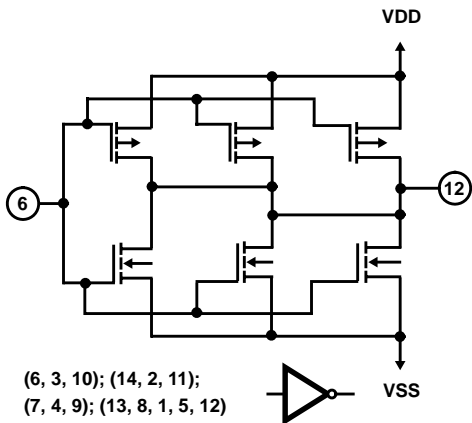

**g) HIGH SINK - AND SOURCE-CURRENT DRIVER**

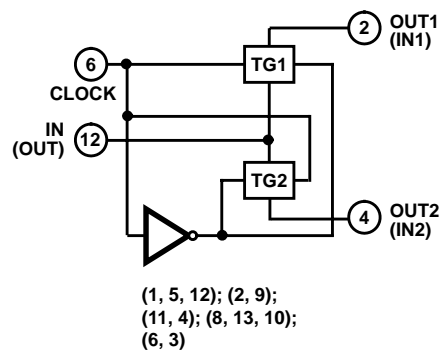

**h) DUAL BI-DIRECTIONAL TRANSMISSION GATING**

**FIGURE 2. SAMPLE CMOS LOGIC CIRCUIT ARRANGEMENTS USING TYPE CD4007UB**

Typical Performance Characteristics

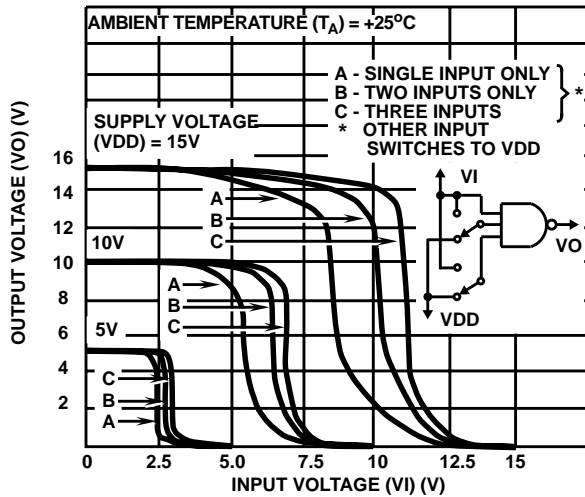

FIGURE 3. TYPICAL VOLTAGE-TRANSFER CHARACTERISTICS FOR NAND GATE

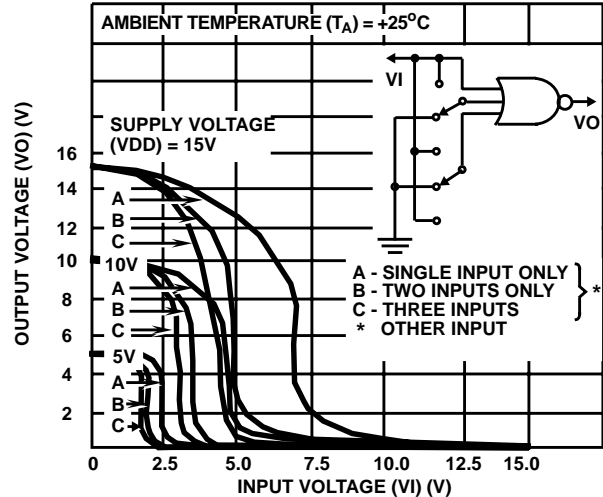

FIGURE 4. TYPICAL VOLTAGE-TRANSFER CHARACTERISTICS FOR NOR GATE

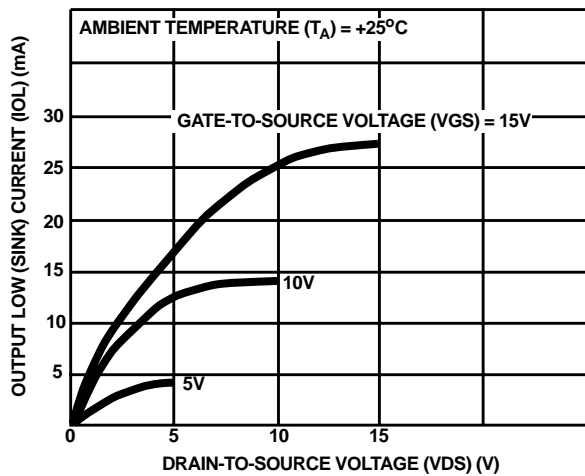

FIGURE 5. TYPICAL OUTPUT LOW (SINK) CURRENT CHARACTERISTICS

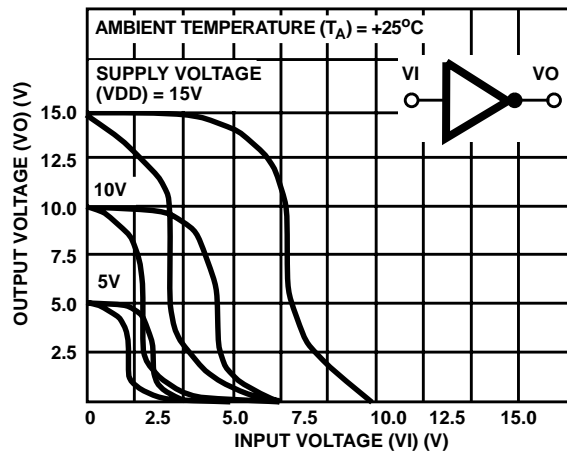

FIGURE 6. MINIMUM AND MAXIMUM VOLTAGE-TRANSFER CHARACTERISTICS FOR INVERTER

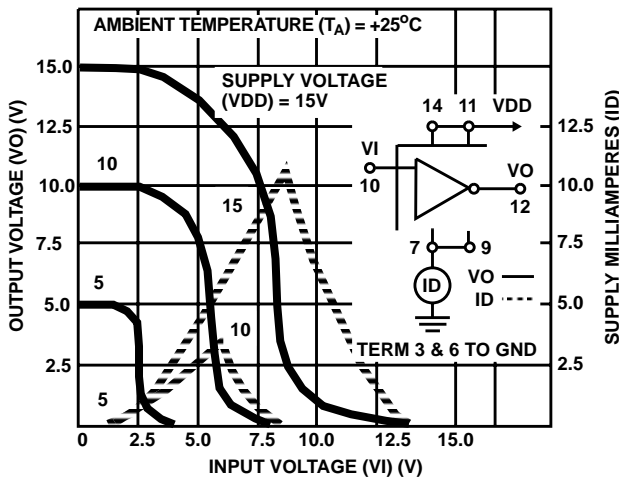

FIGURE 7. TYPICAL CURRENT AND VOLTAGE-TRANSFER CHARACTERISTICS FOR INVERTER

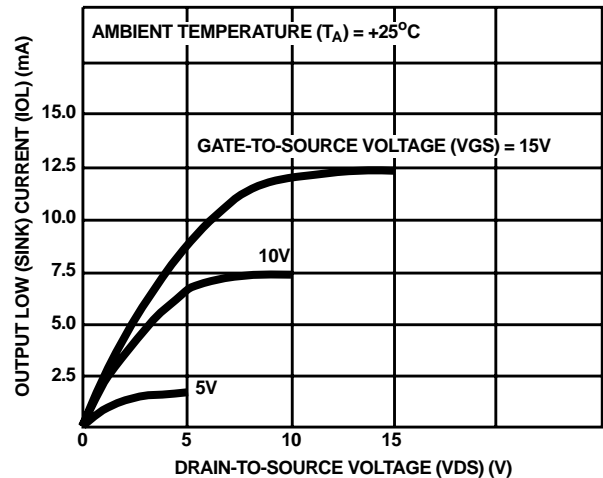
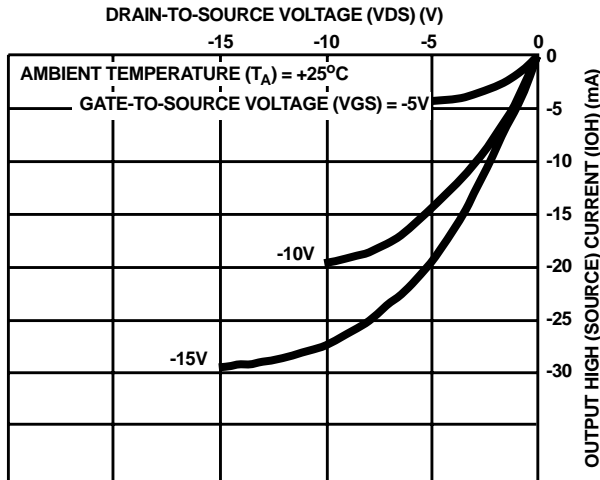
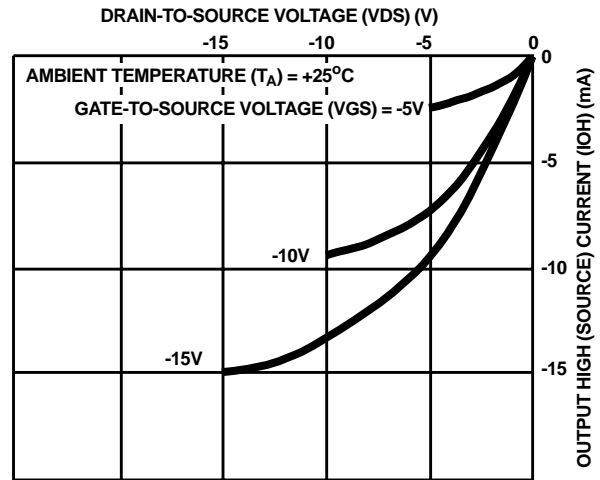

FIGURE 8. MINIMUM OUTPUT LOW (SINK) CURRENT CHARACTERISTICS

**Typical Performance Characteristics (Continued)**



**FIGURE 9. TYPICAL OUTPUT HIGH (SOURCE) CURRENT CHARACTERISTICS**



**FIGURE 10. MINIMUM OUTPUT HIGH (SOURCE) CURRENT CHARACTERISTICS**

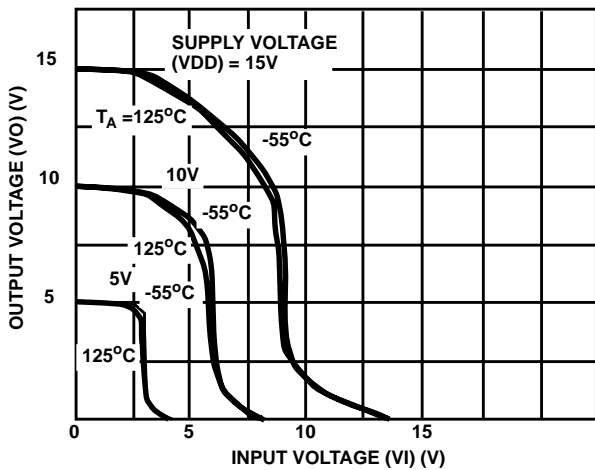

**FIGURE 11. TYPICAL VOLTAGE-TRANSFER CHARACTERISTICS AS A FUNCTION OF TEMPERATURE**

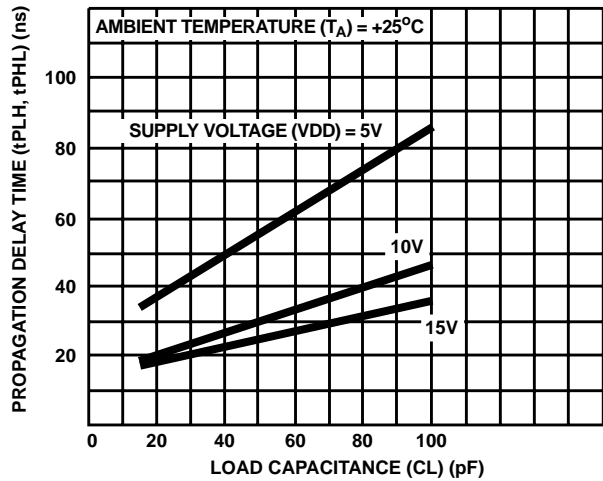

**FIGURE 12. TYPICAL PROPAGATION DELAY TIME vs LOAD CAPACITANCE**

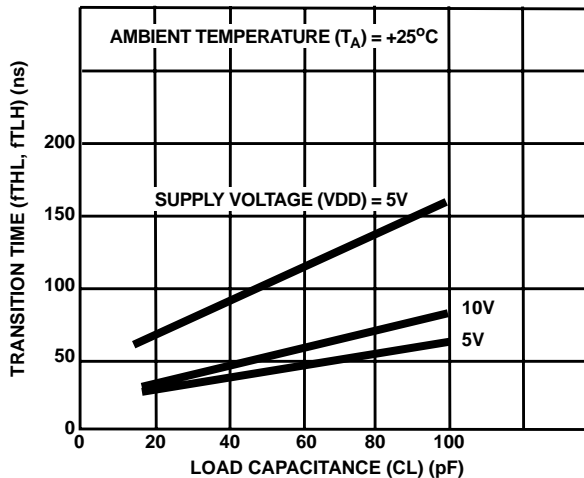

**FIGURE 13. TYPICAL TRANSITION TIME vs LOAD CAPACITANCE**

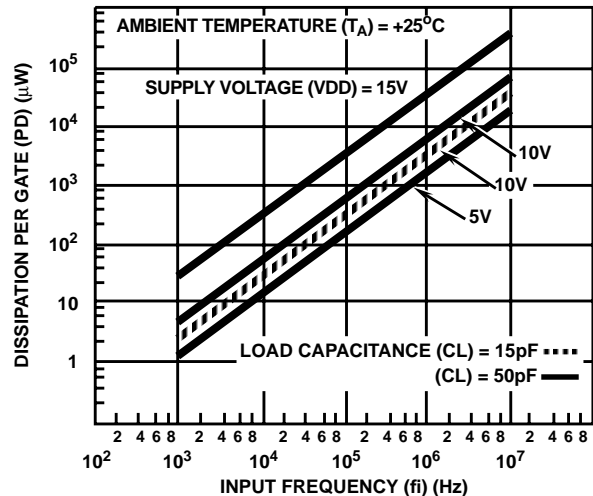

**FIGURE 14. TYPICAL DISSIPATION vs FREQUENCY CHARACTERISTICS**



### Important statement:

Huaguan Semiconductor Co,Ltd. reserves the right to change the products and services provided without notice. Customers should obtain the latest relevant information before ordering, and verify the timeliness and accuracy of this information.

Customers are responsible for complying with safety standards and taking safety measures when using our products for system design and machine manufacturing to avoid potential risks that may result in personal injury or property damage.

Our products are not licensed for applications in life support, military, aerospace, etc., so we do not bear the consequences of the application of these products in these fields.

Our documentation is only permitted to be copied without any tampering with the content, so we do not accept any responsibility or liability for the altered documents.

单击下面可查看定价，库存，交付和生命周期等信息

[>>HGSEMI\(华冠\)](#)