

PUSH-PULL FOUR CHANNEL DRIVER WITH DIODES

600mA OUTPUT CURRENT CAPABILITY PER CHANNEL
 1.2A PEAK OUTPUT CURRENT (non repetitive) PER CHANNEL
 ENABLE FACILITY
 OVERTEMPERATURE PROTECTION
 LOGICAL "0" INPUT VOLTAGE UP TO 1.5 V (HIGH NOISE IMMUNITY)
 INTERNAL CLAMP DIODES

DESCRIPTION

The Device is a monolithic integrated high voltage, high current four channel driver designed to accept standard DTL or TTL logic levels and drive inductive loads (such as relays solenoides, DC and stepping motors) and switching power transistors.

To simplify use as two bridges each pair of channels is equipped with an enable input. A separate supply input is provided for the logic, allowing operation at a lower voltage and internal clamp diodes are included.

This device is suitable for use in switching applications at frequencies up to 5 kHz.

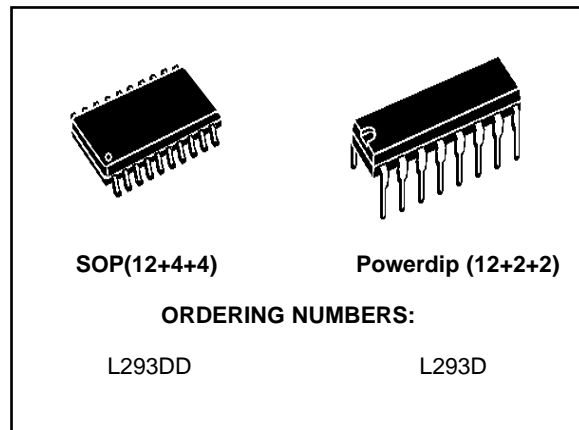

The L293D is assembled in a 16 lead plastic package which has 4 center pins connected together and used for heatsinking

The L293DD is assembled in a 20 lead surface mount which has 8 center pins connected together and used for heatsinking.

ORDERING INFORMATION

DEVICE	Package Type	MARKING	Packing	Packing Qty
L293DN	DIP16	L293D	TUBE	1000/box
L293DDM/TR	SOP20	L293DD	REEL	2000/reel

BLOCK DIAGRAM

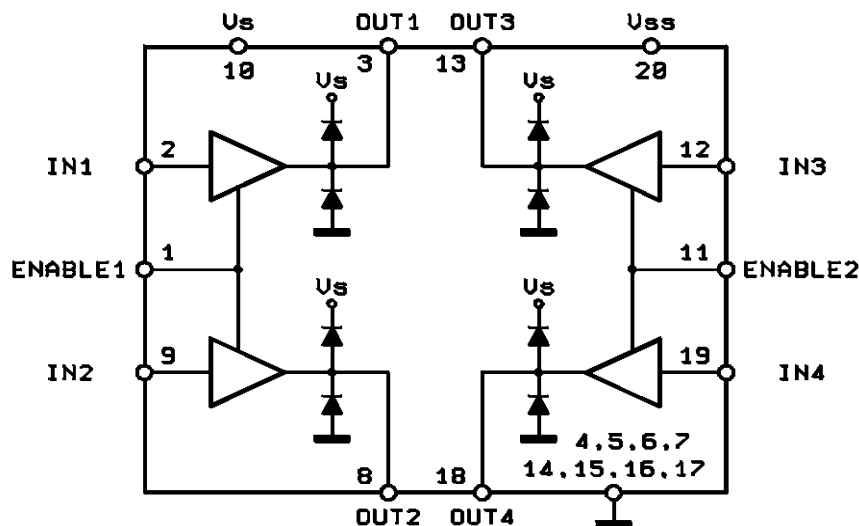

ABSOLUTE MAXIMUM RATINGS

Symbol	Parameter	Value	Unit
V _S	Supply Voltage	36	V
V _{SS}	Logic Supply Voltage	36	V
V _i	Input Voltage	7	V
V _{en}	Enable Voltage	7	V
I _o	Peak Output Current (100 μs non repetitive)	1.2	A
P _{tot}	Total Power Dissipation at T _{pins} = 90 °C	4	W
T _{stg} , T _j	Storage and Junction Temperature	- 40 to 150	°C

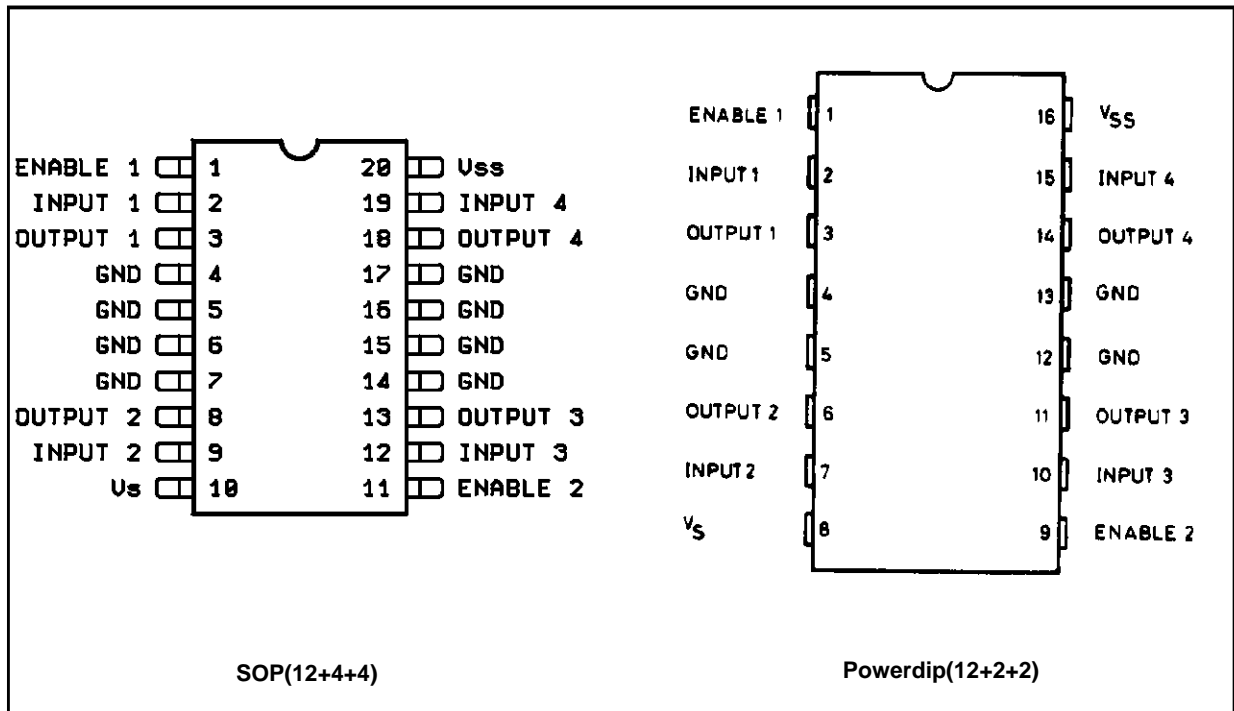
PIN CONNECTIONS (Top view)

THERMAL DATA

Symbol	Decription		DIP	SOP	Unit
R _{th j-pins}	Thermal Resistance Junction-pins	max.	–	14	°C/W
R _{th j-amb}	Thermal Resistance junction-ambient	max.	80	50 (*)	°C/W
R _{th j-case}	Thermal Resistance Junction-case	max.	14	–	

(*) With 6sq. cm on board heatsink.

ELECTRICAL CHARACTERISTICS (for each channel, $V_S = 24\text{ V}$, $V_{SS} = 5\text{ V}$, $T_{amb} = 25\text{ }^\circ\text{C}$, unless otherwise specified)

Symbol	Parameter	Test Conditions	Min.	Typ.	Max.	Unit
V_S	Supply Voltage (pin 10)		V_{SS}		36	V
V_{SS}	Logic Supply Voltage (pin 20)		4.5		36	V
I_S	Total Quiescent Supply Current (pin 10)	$V_i = L$; $I_O = 0$; $V_{en} = H$		2	6	mA
		$V_i = H$; $I_O = 0$; $V_{en} = H$		16	24	mA
		$V_{en} = L$			4	mA
I_{SS}	Total Quiescent Logic Supply Current (pin 20)	$V_i = L$; $I_O = 0$; $V_{en} = H$		44	60	mA
		$V_i = H$; $I_O = 0$; $V_{en} = H$		16	22	mA
		$V_{en} = L$		16	24	mA
V_{IL}	Input Low Voltage (pin 2, 9, 12, 19)		-0.3		1.5	V
V_{IH}	Input High Voltage (pin 2, 9, 12, 19)	$V_{SS} \leq 7\text{ V}$	2.3		V_{SS}	V
		$V_{SS} > 7\text{ V}$	2.3		7	V
I_{IL}	Low Voltage Input Current (pin 2, 9, 12, 19)	$V_{IL} = 1.5\text{ V}$			-10	μA
I_{IH}	High Voltage Input Current (pin 2, 9, 12, 19)	$2.3\text{ V} \leq V_{IH} \leq V_{SS} - 0.6\text{ V}$		30	100	μA
V_{enL}	Enable Low Voltage (pin 1, 11)		-0.3		1.5	V
V_{enH}	Enable High Voltage (pin 1, 11)	$V_{SS} \leq 7\text{ V}$	2.3		V_{SS}	V
		$V_{SS} > 7\text{ V}$	2.3		7	V
I_{enL}	Low Voltage Enable Current (pin 1, 11)	$V_{enL} = 1.5\text{ V}$		-30	-100	μA
I_{enH}	High Voltage Enable Current (pin 1, 11)	$2.3\text{ V} \leq V_{enH} \leq V_{SS} - 0.6\text{ V}$			± 10	μA
$V_{CE(sat)H}$	Source Output Saturation Voltage (pins 3, 8, 13, 18)	$I_O = -0.6\text{ A}$		1.4	1.8	V
$V_{CE(sat)L}$	Sink Output Saturation Voltage (pins 3, 8, 13, 18)	$I_O = +0.6\text{ A}$		1.2	1.8	V
V_F	Clamp Diode Forward Voltage	$I_O = 600\text{ nA}$		1.3		V
t_r	Rise Time (*)	0.1 to 0.9 V_O		250		ns
t_f	Fall Time (*)	0.9 to 0.1 V_O		250		ns
t_{on}	Turn-on Delay (*)	0.5 V_i to 0.5 V_O		750		ns
t_{off}	Turn-off Delay (*)	0.5 V_i to 0.5 V_O		200		ns

(*) See fig. 1.

TRUTH TABLE (one channel)

Input	Enable (*)	Output
H	H	H
L	H	L
H	L	Z
L	L	Z

Z = High output impedance

(*) Relative to the considered channel

Figure 1: Switching Times

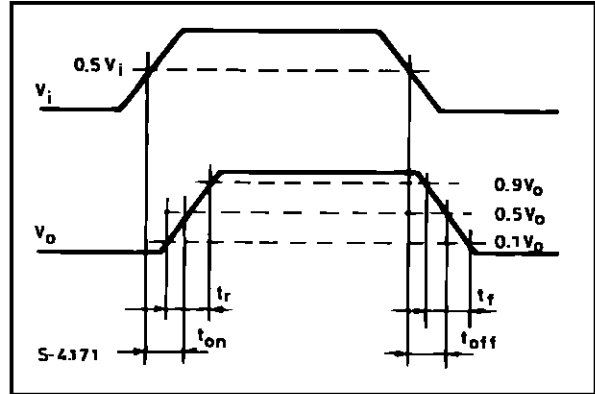
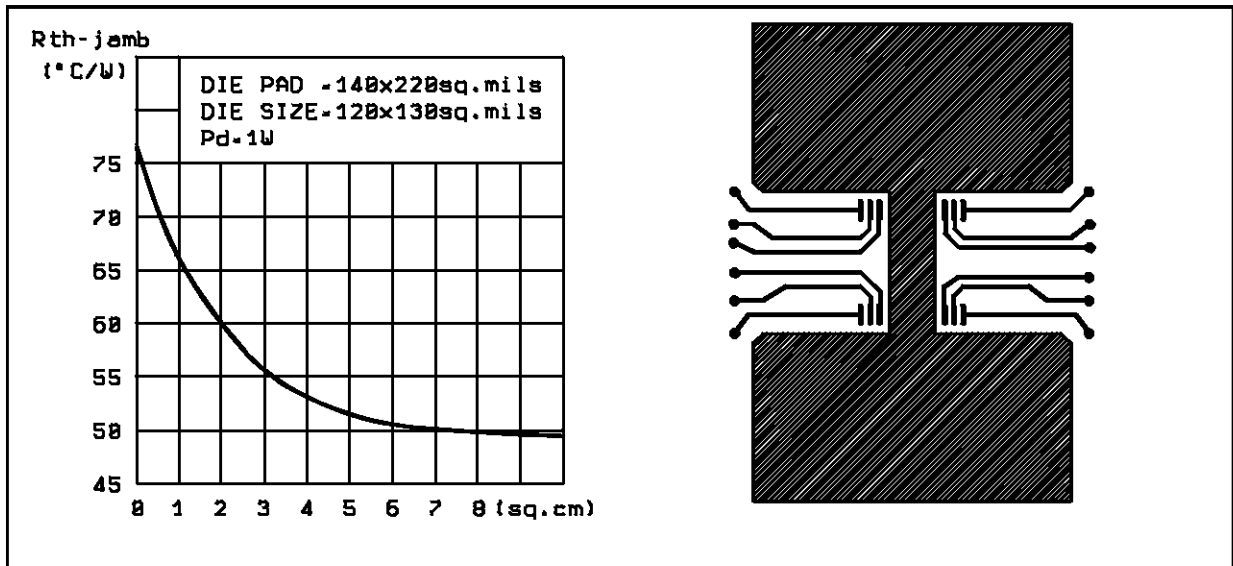

Figure 2: Junction to ambient thermal resistance vs. area on board heatsink (SOP12+4+4 package)



Important statement:

Huaguan Semiconductor Co,Ltd. reserves the right to change the products and services provided without notice. Customers should obtain the latest relevant information before ordering, and verify the timeliness and accuracy of this information.

Customers are responsible for complying with safety standards and taking safety measures when using our products for system design and machine manufacturing to avoid potential risks that may result in personal injury or property damage.

Our products are not licensed for applications in life support, military, aerospace, etc., so we do not bear the consequences of the application of these products in these fields.

Our documentation is only permitted to be copied without any tampering with the content, so we do not accept any responsibility or liability for the altered documents.

单击下面可查看定价，库存，交付和生命周期等信息

[>>HGSEMI\(华冠\)](#)