

250MHz CMOS Rail-to-Rail Output Opamps

Features

- Single-Supply Operation from +2.5V ~ +5.5V
- Rail-to-Rail Output
- -3dB Bandwidth(G=+1): 250MHz (Typ)
- Low Input Bias Current: 1pA (Typ)
- Quiescent Current: 2.8mA/Amplifier (Typ)
- Operating Temperature: -40°C ~ +125°C
- Small Package:

AD8051 Available in SOT23-5 and SC70-5 Packages

AD8052 Available in SOP-8,MSOP-8 and DFN-8 Packages

AD8054 Available in SOP-14 and TSSOP-14 Packages



Ordering Information

DEVICE	Package Type	MARKING	Packing	Packing Qty
AD8051M5/TR	SOT-23-5	8051	REEL	3000pcs/reel
AD8051M7/TR	SC70-5	8051	REEL	3000pcs/reel
AD8052M/TR	SOP-8	AD8052	REEL	2500pcs/reel
AD8052MM/TR	MSOP-8	8052	REEL	3000pcs/reel
AD8052DQ/TR	DFN-8 2*2	AD8052	REEL	3000pcs/reel
AD8054M/TR	SOP-14	AD8054	REEL	2500pcs/reel
AD8054MT/TR	TSSOP-14	AD8054	REEL	2500pcs/reel

General Description

The AD8051(single), AD8052(dual), AD8054(quad) are rail-to-rail output voltage feedback amplifiers offering ease of use and low cost. They have bandwidth and slew rate typically found in current feedback amplifiers. All have a wide input common-mode voltage range and output voltage swing, making them easy to use on single supplies as low as 2.5V. Despite being low cost, the AD805X series provide excellent overall performance. They offer wide bandwidth to 250MHz (G = +1) along with 0.1dB flatness out to 52MHz (G = +2) and offer a typical low power of 2.8mA/amplifier.

The AD805X series is low distortion and fast settling make it ideal for buffering high speed A/D or D/A converters. The AD8051 has a power-down disable feature that reduces the supply current to 50µA. These features make the AD8051/2 ideal for portable and battery-powered applications where size and power are critical. All are specified over the extended -40°C to +125°C temperature range.

Applications

- Imaging
- Photodiode Preamp
- DVD/CD
- Filters
- Professional Video and Cameras
- Hand Sets
- Base Stations
- A-to-D Driver

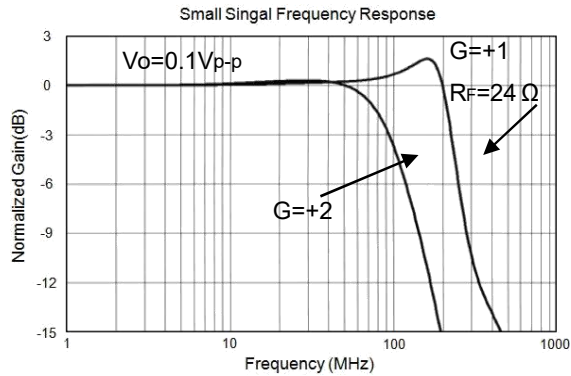

Pin Configuration

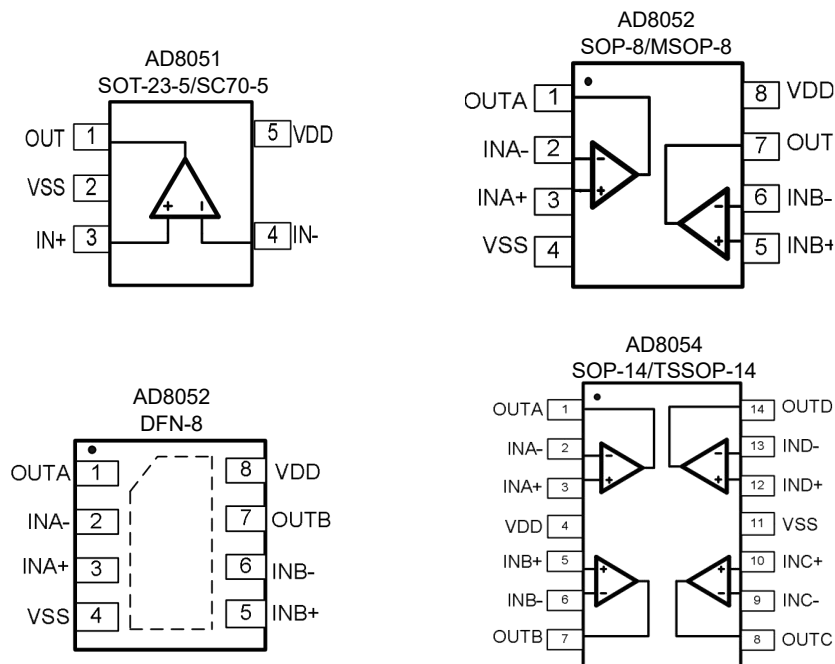

Figure 1. Pin Assignment Diagram

Absolute Maximum Ratings

Condition	Min	Max
Power Supply Voltage (VDD to Vss)	-0.5V	+7.5V
Analog Input Voltage (IN+ or IN-)	Vss-0.5V	VDD+0.5V
PDB Input Voltage	Vss-0.5V	+7V
Operating Temperature Range	-40°C	+125°C
Junction Temperature	+160°C	
Storage Temperature Range	-55°C	+150°C
Lead Temperature (soldering, 10sec)	+245°C	
Package Thermal Resistance (TA=+25°C)		
SOP-8, θ_{JA}	125°C/W	
MSOP-8, θ_{JA}	216°C/W	
SOT23-5, θ_{JA}	190°C/W	
SC70-5, θ_{JA}	333°C/W	
ESD Susceptibility		
HBM	6KV	
MM	400V	

Note:

Stress greater than those listed under Absolute Maximum Ratings may cause permanent damage to the device. This is a stress rating only and functional operation of the device at these or any other conditions outside those indicated in the operational sections of this specification are not implied. Exposure to absolute maximum rating conditions for extended periods may affect reliability.

Electrical Performance Characteristics

 (G= +2, R_F=887Ω, R_G=887Ω, and R_L=150Ω connected to V_S/2, unless otherwise noted. Typical values are at T_A =+25°C.)

PARAMETER	CONDITIONS	AD8051/52/54							
		TYP	MIN/MAX OVER TEMPERATURE					UNITS	MIN/MAX
		+25°C	+25°C	0°C to 70°C	-40°C to 85°C	-40°C to 125°C			
DYNAMIC PERFORMANCE									
-3dB Small Signal Bandwidth	G = +1, V _o = 0.1V p-p, R _F = 24Ω, R _L = 150Ω	180						MHz	TYP
	G = +1, V _o = 0.1V p-p, R _F = 24Ω, R _L = 1kΩ	250						MHz	TYP
	G = +2, V _o = 0.1V p-p, R _L = 50Ω	55						MHz	TYP
	G = +2, V _o = 0.1V p-p, R _L = 150Ω	93						MHz	TYP
	G = +2, V _o = 0.1V p-p, R _L = 1kΩ	122						MHz	TYP
	G = +2, V _o = 0.1V p-p, R _L = 10kΩ	130						MHz	TYP
Gain-Bandwidth Product	G = +10, R _L = 150Ω	115						MHz	TYP
	G = +10, R _L = 1kΩ	150						MHz	TYP
Bandwidth for 0.1dB Flatness	G = +2, V _o = 0.1V p-p, R _L = 150Ω, R _F = 887Ω	52						MHz	TYP
Slew Rate	G = +1, 2V Output Step	77/-151						V/μs	TYP
	G = +2, 2V Output Step	88/-119						V/μs	TYP
	G = +2, 4V Output Step	93/-131						V/μs	TYP
Rise-and-Fall Time	G = +2, V _o = 0.2Vp-p, 10% to 90%	4.5						ns	TYP
	G = +2, V _o = 2Vp-p, 10% to 90%	18						ns	TYP
Settling Time to 0.1%	G = +2, 2V Output Step	50						ns	TYP
Overload Recovery Time	V _{IN} · G = +VS	18						ns	TYP
NOISE/DISTORTION PERFORMANCE									
Input Voltage Noise	f = 1MHz	4.9						nV/ Hz	TYP
Differential Gain Error (NTSC)	G = +2, R _L = 150Ω	0.03						%	TYP
Differential Phase Error (NTSC)	G = +2, R _L = 150Ω	0.08						degree	TYP
DC PERFORMANCE									
Input Offset Voltage (VOS)		±2	±8	±8.9	±9.5	±9.8		mV	MAX
Input Offset Voltage Drift		2						μV/°C	TYP
Input Bias Current (IB)		1						PA	TYP
Input offset Current (IOS)		2						PA	TYP
Open-Loop Gain (AOL)	V _O = 0.3V to 4.7V, R _L = 150Ω	80	75	74	74	73		dB	MIN
	V _O = 0.2V to 4.8V, R _L = 1kΩ	104	92	91	91	80		dB	MIN
INPUT CHARACTERISTICS									
Input Common-Mode Voltage Range (VCM)	V _{CM} = -0.1V to +3.5V	-0.2 to +3.8						V	TYP MIN
Common-Mode Rejection Ratio (CMRR)		80	66	65	65	62		dB	

Electrical Performance Characteristics

 (G= +2, R_F=887Ω, R_G=887Ω, and R_L=150Ω connected to VS/2, unless otherwise noted. Typical values are at T_A=+25°C.)

PARAMETER	CONDITIONS	AD8051/52/54							
		TYP	MIN/MAX OVER TEMPERATURE					UNITS	MIN/ MAX
		+25°C	+25°C	0°C to70°C	-40°Cto 85°C	-40°C to125°C			
OUTPUT CHARACTERISTICS									
Output Voltage Swing from Rail	R _L = 150Ω	0.12						V	TYP
	R _L = 1kΩ	0.03						V	TYP
Output Current		80	60					mA	MIN
Closed-Loop Output Impedance	f < 100kHz	0.08						Ω	TYP
POWER-DOWN DISABLE (AD8051/2 only)									
Turn-On Time		236						ns	TYP
Turn-Off Time		52						ns	TYP
DISABLE Voltage-Off			0.8					V	MAX
DISABLE Voltage-On			2					V	MIN
POWER SUPPLY									
Operating Voltage Range			2.5	2.7	2.7	2.7		V	MIN
			5.5	5.5	5.5	5.5		V	MAX
Quiescent Current (per amplifier)		2.8	3.65					mA	MAX
Supply Current when Disabled per amplifier(AD8051/2 only)		50	70	85	100	137		μA	MAX
Power Supply Rejection Ratio (PSRR)	ΔVS = +2.7V to +5.5V, VCM = (-VS) +0.5	80	67	67	65	62		dB	MIN

Typical Performance characteristics

($V_s=+5V, G=+2, R_F=887\Omega, R_G=887\Omega,$ and $R_L=150\Omega$ connected to $V_s/2$, Typical values are at $T_A=+25^\circ C$.)

Non-Inverting Large-Signal Step Response



Time (50ns/div)

Non-Inverting Small-Signal Step Response

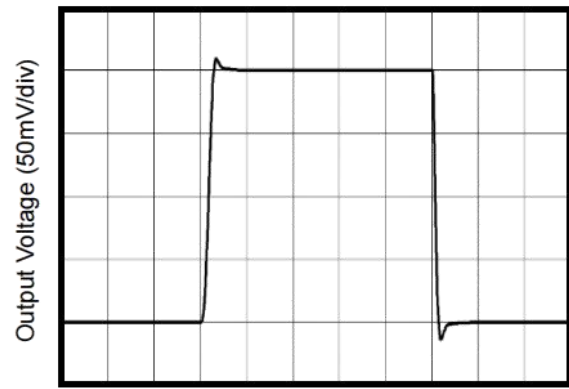

Time (50ns/div)

Supply Current vs. Temperature

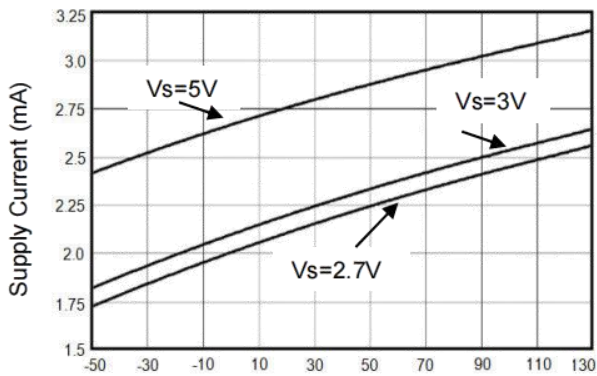

Temperature (°C)

Shutdown Current vs. Temperature

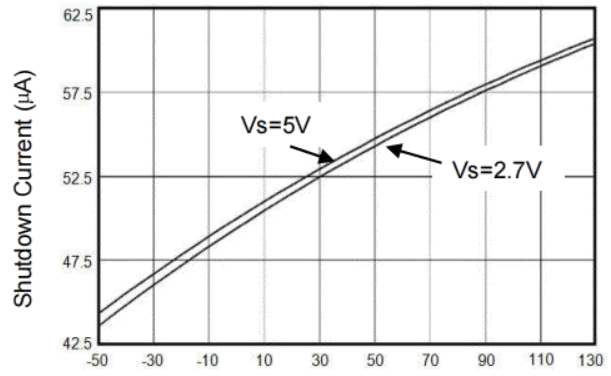

Temperature (°C)

Output Voltage Swing vs. Output Current

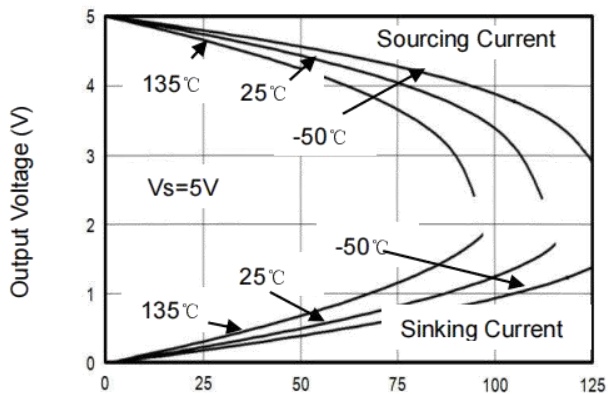

Output Current (mA)

Output Voltage vs. Output Current

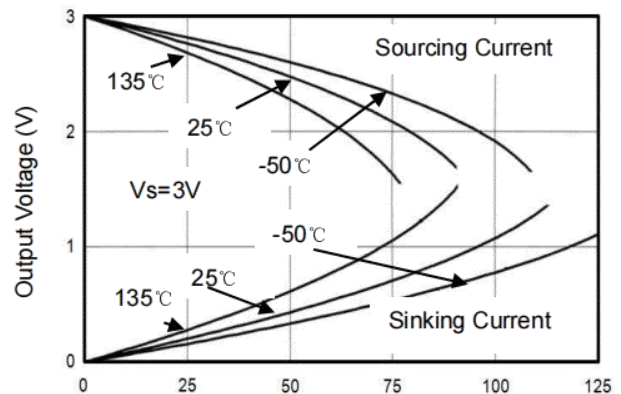

Output Current (mA)

Typical Performance characteristics

((Vs=+5V,G= +2, R_F=887Ω,R_G=887Ω,and R_L=150Ωconnected to Vs/2,Typical values are at T_A =+25°C.)

Non-Inverting Small Signal Frequency Response

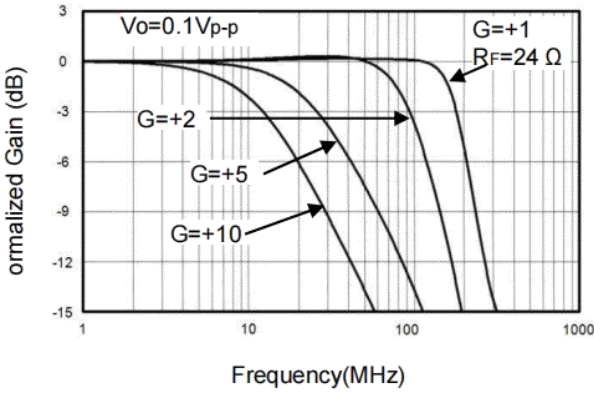

Inverting Small Signal Frequency Response

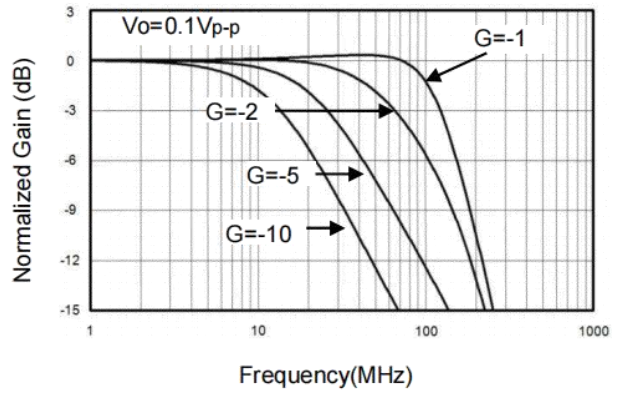

Frequency Response For Various R_L

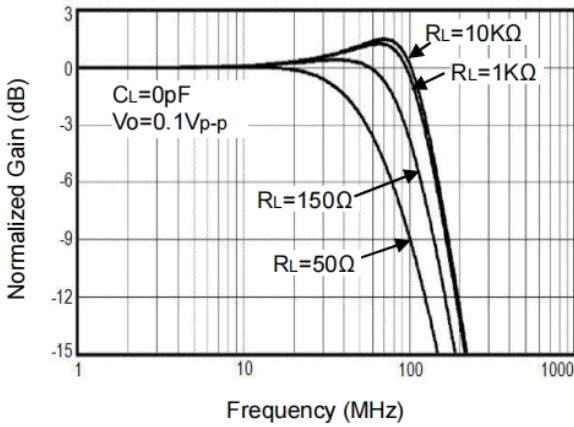

0.1dB Gain Flatness For Various R_F

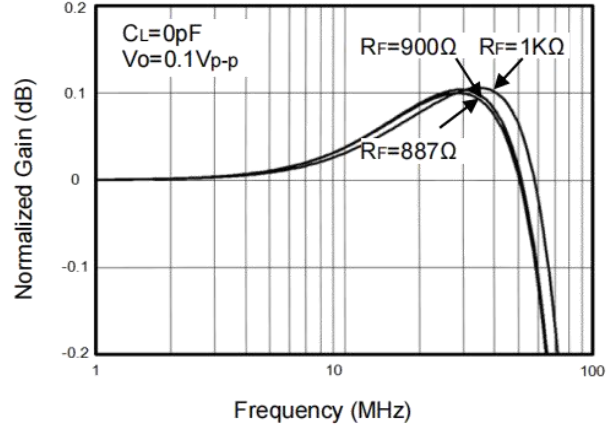

Frequency Response For Various C_L

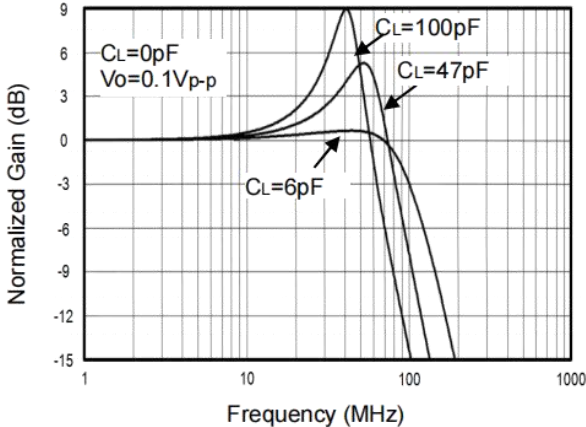

Frequency Response vs.Capacitive Load

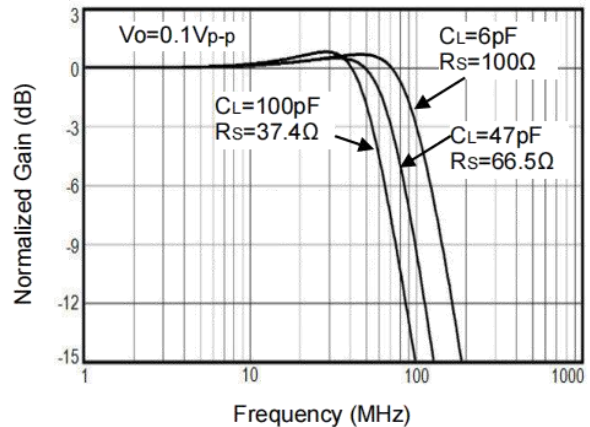

Typical Performance characteristics

($V_S=+5V, G=+2, R_F=887\Omega, R_G=887\Omega,$ and $R_L=150\Omega$ connected to $V_S/2$, Typical values are at $T_A=+25^\circ C$.)

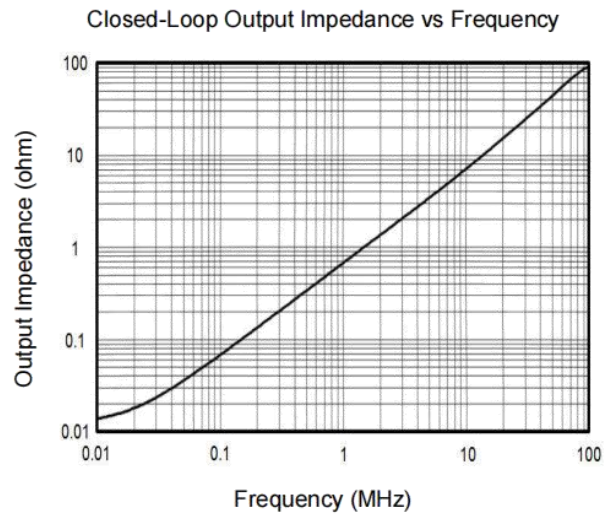
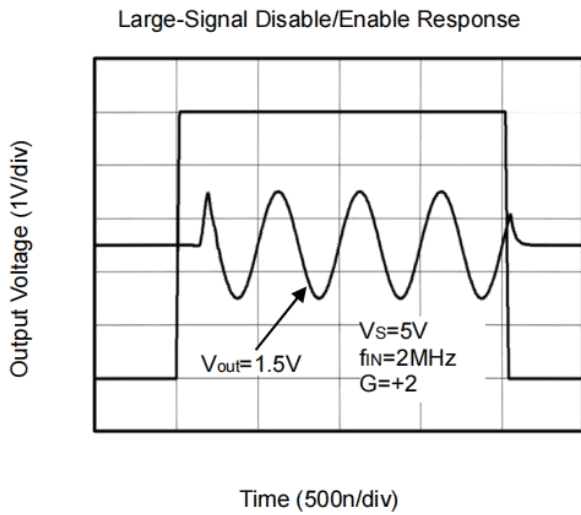
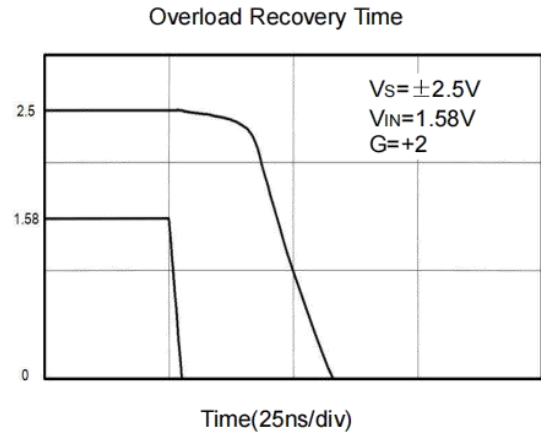
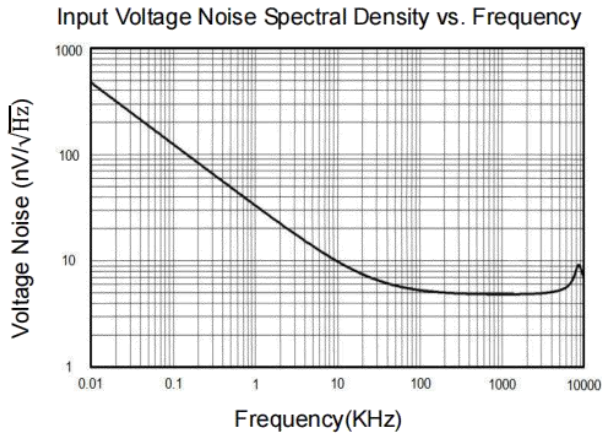

Application Note

Driving Capacitive Loads

AD805X series op amps are unity-gain stable and suitable for a wide range of general-purpose applications. The small footprints of the AD805X series packages save space on printed circuit boards and enable the design of smaller electronic products.

Power Supply Bypassing and Board Layout

AD805X series operates from a single 2.5V to 5.5V supply or dual $\pm 1.25\text{V}$ to $\pm 2.75\text{V}$ supplies. For best performance, a $0.1\mu\text{F}$ ceramic capacitor should be placed close to the V_{DD} pin in single supply operation. For dual supply operation, both V_{DD} and V_{SS} supplies should be bypassed to ground with separate $0.1\mu\text{F}$ ceramic capacitors.

Low Supply Current

The low supply current (typical 2.8mA per channel) of AD805X series will help to maximize battery life. They are ideal for battery powered systems.

Operating Voltage

AD805X series operate under wide input supply voltage (2.5V to 5.5V). In addition, all temperature specifications apply from

-40°C to $+125^{\circ}\text{C}$. Most behavior remains unchanged throughout the full operating voltage range. These guarantees ensure operation throughout the single Li-Ion battery lifetime.

Rail-to-Rail Output

Rail-to-Rail output swing provides maximum possible dynamic range at the output. This is particularly important when operating in low supply voltages. The output voltage of AD805X series can typically swing to less than 8mV from supply rail in light resistive loads ($>1\text{k}\Omega$), and 30mV of supply rail in moderate resistive loads (150Ω).

Capacitive Load Tolerance

The AD805X family is optimized for bandwidth and speed, not for driving capacitive loads. Output capacitance will create a pole in the amplifier's feedback path, leading to excessive peaking and potential oscillation. If dealing with load capacitance is a requirement of the application, the two strategies to consider are (1) using a small resistor in series with the amplifier's output and the load capacitance and (2) reducing the bandwidth of the amplifier's feedback loop by increasing the overall noise gain. Figure 2. shows a unity gain follower using the series resistor strategy. The resistor isolates the output from the capacitance and, more importantly, creates a zero in the feedback path that compensates for the pole created by the output capacitance.

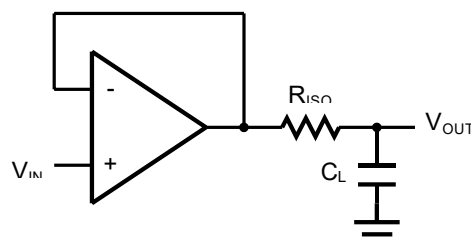

Figure 2. Indirectly Driving a Capacitive Load Using Isolation Resistor

The bigger the RISO resistor value, the more stable V_{OUT} will be. However, if there is a resistive load R_L in parallel with the capacitive load, a voltage divider (proportional to R_{ISO}/R_L) is formed, this will result in a gain error.

The circuit in Figure 3 is an improvement to the one in Figure 2. R_F provides the DC accuracy by feed-forward the V_{IN} to R_L . C_F and R_{ISO} serve to counteract the loss of phase margin by feeding the high frequency component of the output signal back to the amplifier's inverting input, thereby preserving the phase margin in the overall feedback loop. Capacitive drive can be increased by increasing the value of C_F . This in turn will slow down the pulse response.

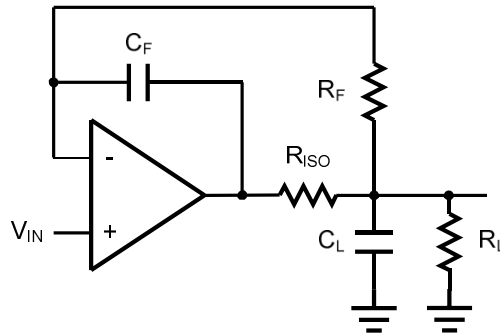

Figure 3. Indirectly Driving a Capacitive Load with DC Accuracy

Typical Application Circuits

Differential amplifier

The differential amplifier allows the subtraction of two input voltages or cancellation of a signal common to the two inputs. It is useful as a computational amplifier in making a differential to single-end conversion or in rejecting a common mode signal.

Figure 4. shown the differential amplifier using AD805X.

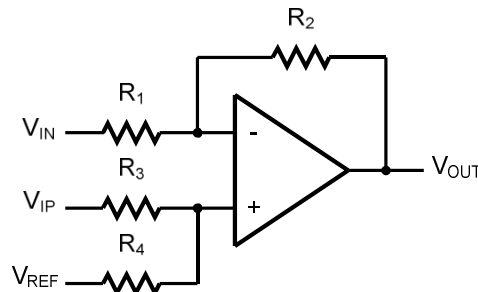

Figure 4. Differential Amplifier

$$V_{OUT} = \left(\frac{R_1+R_2}{R_3+R_4}\right) \frac{R_4}{R_1} V_{IN} - \frac{R_2}{R_1} V_{IP} + \left(\frac{R_1+R_2}{R_3+R_4}\right) \frac{R_3}{R_1} V_{REF}$$

If the resistor ratios are equal (i.e. $R_1=R_3$ and $R_2=R_4$), then

$$V_{OUT} = \frac{R_2}{R_1} (V_{IP} - V_{IN}) + V_{REF}$$

Low Pass Active Filter

The low pass active filter is shown in Figure 5. The DC gain is defined by $-R_2/R_1$. The filter has a -20dB/decade roll-off after its corner frequency $f_C=1/(2\pi R_3C_1)$.

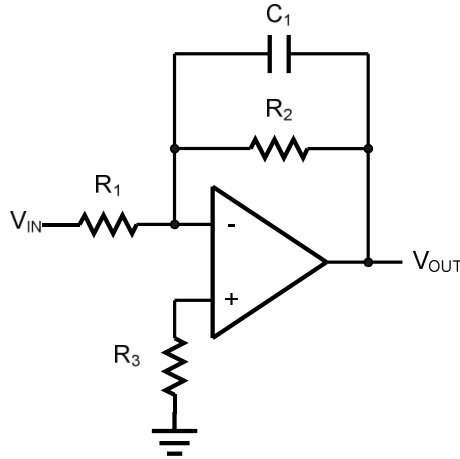

Figure 5. Low Pass Active Filter

Driving Video

The AD805X can be used in video applications like in Figure 6.

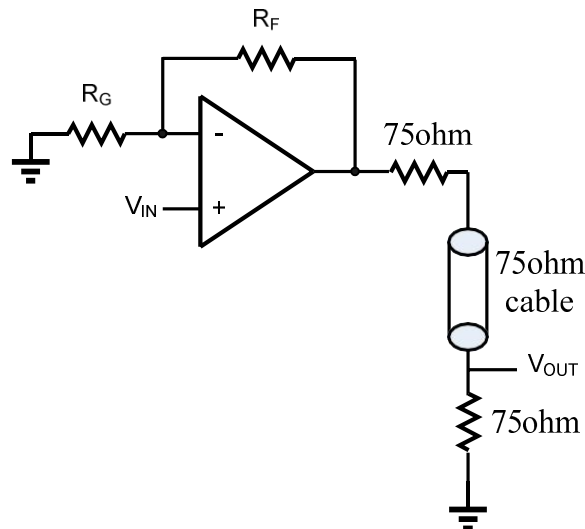
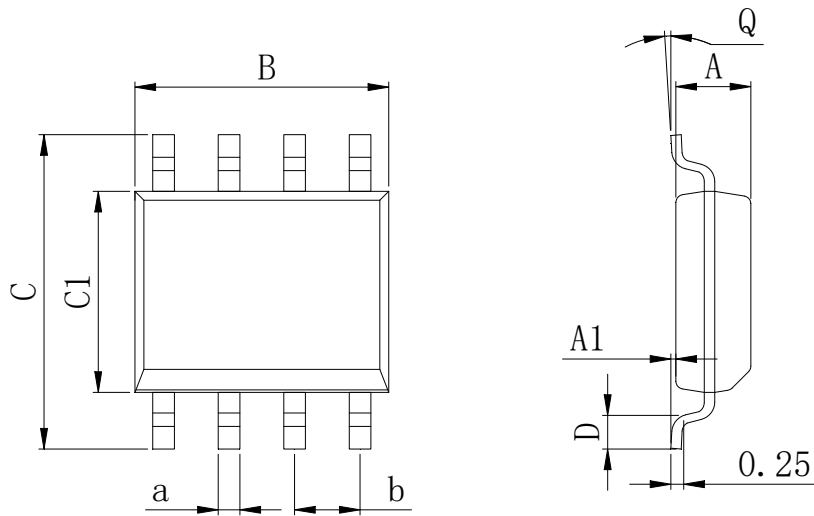

Figure 6. Typical video driving

Physical Dimensions

SOP-8



Dimensions In Millimeters(SOP-8)

Symbol:	A	A1	B	C	C1	D	Q	a	b
Min:	1.35	0.05	4.90	5.80	3.80	0.40	0°	0.35	1.27 BSC
Max:	1.55	0.20	5.10	6.20	4.00	0.80	8°	0.45	

MSOP-8

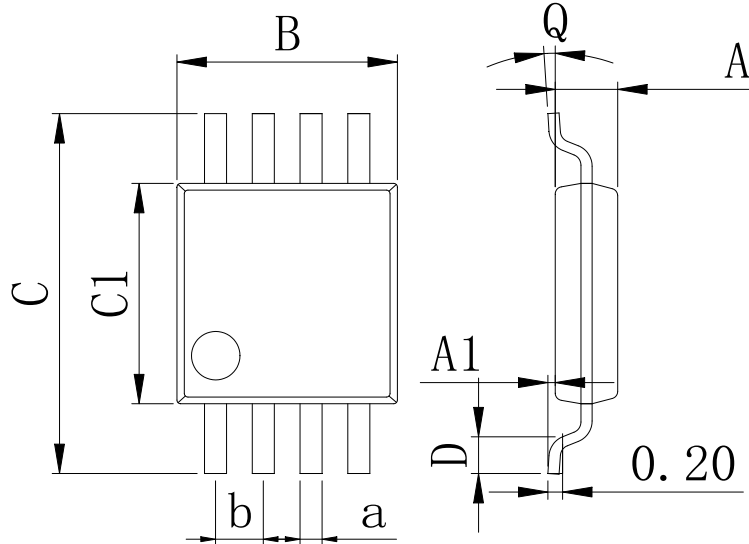

Dimensions In Millimeters(MSOP-8)

Symbol:	A	A1	B	C	C1	D	Q	a	b
Min:	0.80	0.05	2.90	4.75	2.90	0.35	0°	0.25	0.65 BSC
Max:	0.90	0.20	3.10	5.05	3.10	0.75	8°	0.35	

Physical Dimensions

SOP-14

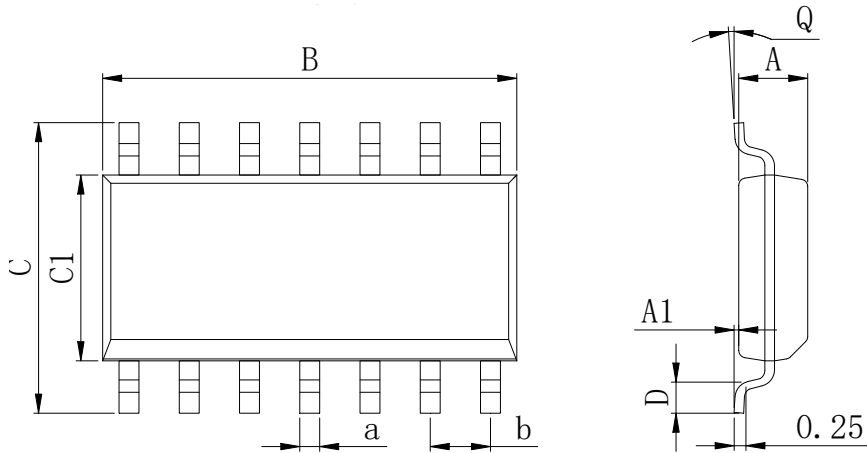

Dimensions In Millimeters(SOP-14)									
Symbol:	A	A1	B	C	C1	D	Q	a	b
Min:	1.35	0.05	8.55	5.80	3.80	0.40	0°	0.35	1.27 BSC
Max:	1.55	0.20	8.75	6.20	4.00	0.80	8°	0.45	

TSSOP-14

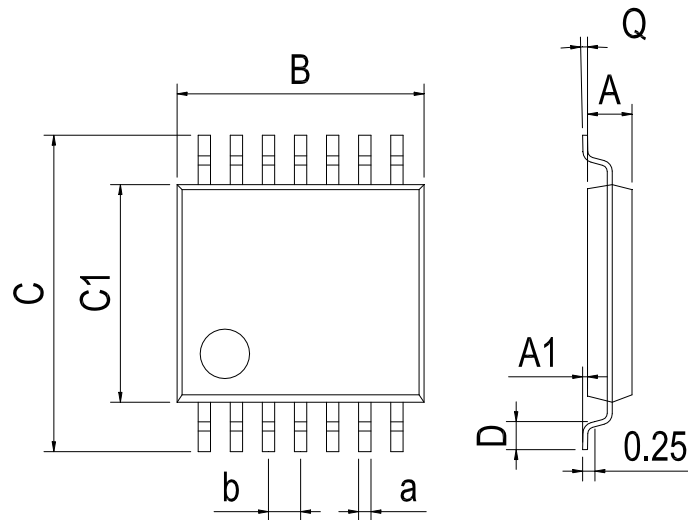

Dimensions In Millimeters(TSSOP-14)									
Symbol:	A	A1	B	C	C1	D	Q	a	b
Min:	0.85	0.05	4.90	6.20	4.30	0.40	0°	0.20	0.65 BSC
Max:	0.95	0.20	5.10	6.60	4.50	0.80	8°	0.25	

Physical Dimensions

SOT-23-5

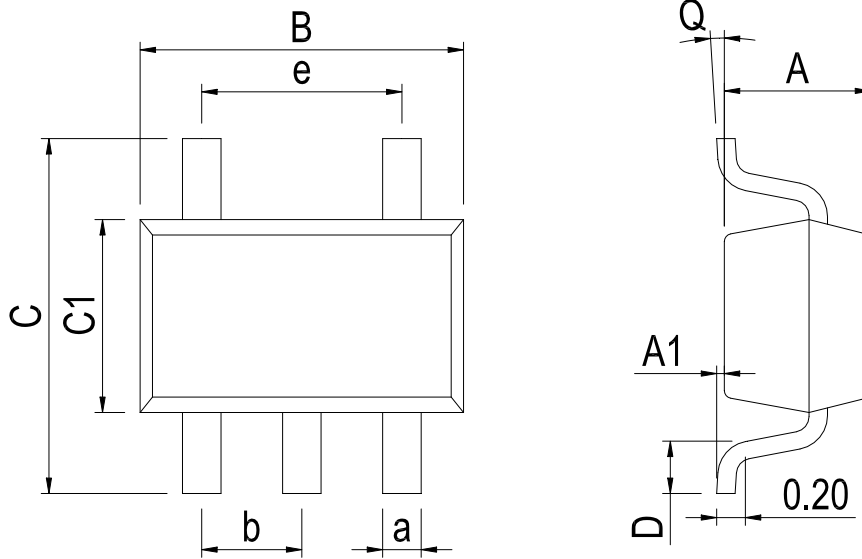

Dimensions In Millimeters(SOT23-5)										
Symbol:	A	A1	B	C	C1	D	Q	a	b	e
Min:	1.05	0.00	2.82	2.65	1.50	0.30	0°	0.30	0.95 BSC	1.90 BSC
Max:	1.15	0.15	3.02	2.95	1.70	0.60	8°	0.40		

SC70-5

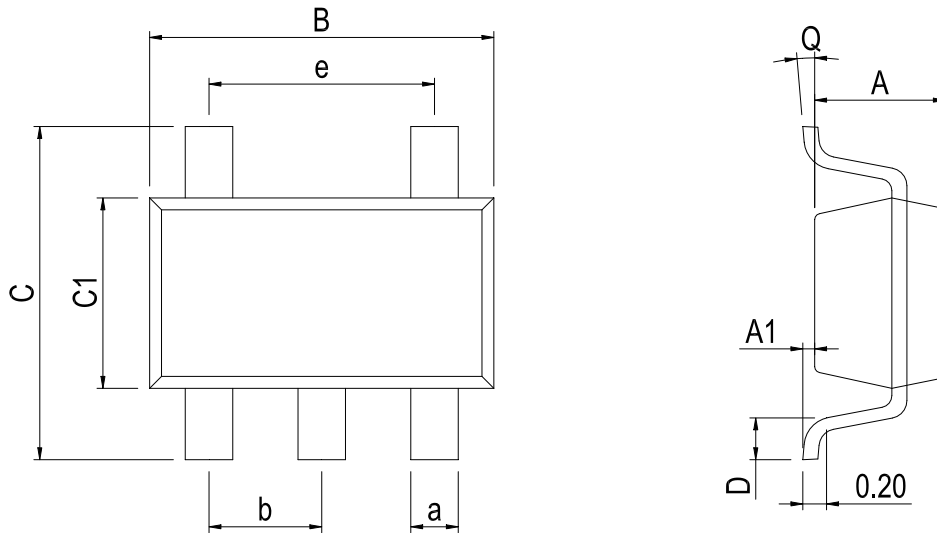

Dimensions In Millimeters(SC70-5)										
Symbol:	A	A1	B	C	C1	D	Q	a	b	e
Min:	0.90	0.00	2.00	2.15	1.15	0.26	0°	0.15	0.65	1.30 BSC
Max:	1.00	0.15	2.20	2.45	1.35	0.46	8°	0.35	BSC	

Physical Dimensions

DFN-8 2*2

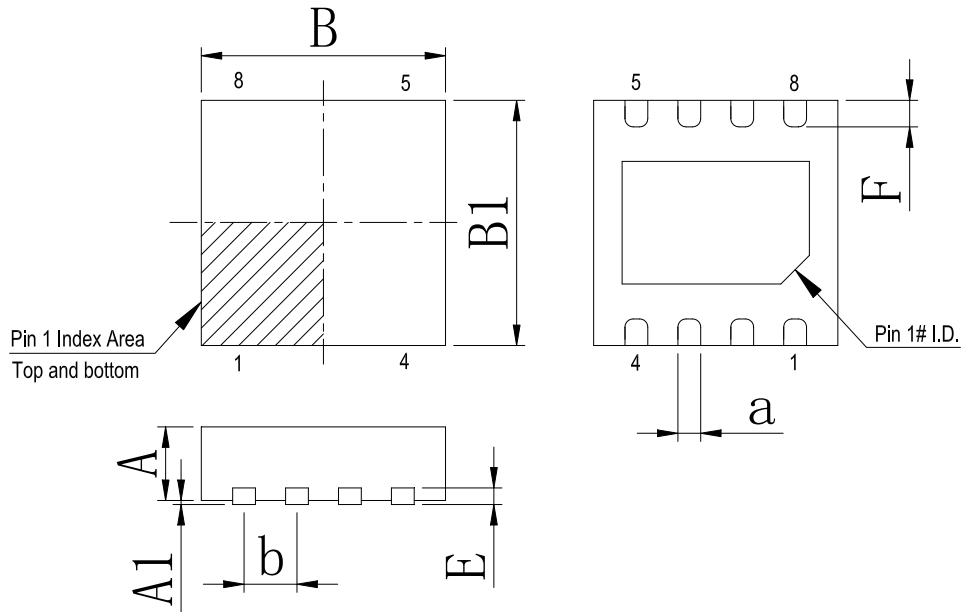

Dimensions In Millimeters(DFN-8 2*2)								
Symbol:	A	A1	B	B1	E	F	a	b
Min:	0.85	0	1.90	1.90	0.15	0.25	0.18	0.50TYP
Max:	0.95	0.05	2.10	2.10	0.25	0.45	0.30	

Revision History

DATE	REVISION	PAGE
2020-6-9	New	1-17
2023-10-30	Update Lead Temperature、 Update encapsulation type、 Update SC70-5 Physical Dimensions	3、 1、 14

IMPORTANT STATEMENT:

Huaguan Semiconductor reserves the right to change its products and services without notice. Before ordering, the customer shall obtain the latest relevant information and verify whether the information is up to date and complete. Huaguan Semiconductor does not assume any responsibility or obligation for the altered documents.

Customers are responsible for complying with safety standards and taking safety measures when using Huaguan Semiconductor products for system design and machine manufacturing. You will bear all the following responsibilities: Select the appropriate Huaguan Semiconductor products for your application; Design, validate and test your application; Ensure that your application meets the appropriate standards and any other safety, security or other requirements. To avoid the occurrence of potential risks that may lead to personal injury or property loss.

Huaguan Semiconductor products have not been approved for applications in life support, military, aerospace and other fields, and Huaguan Semiconductor will not bear the consequences caused by the application of products in these fields. All problems, responsibilities and losses arising from the user's use beyond the applicable area of the product shall be borne by the user and have nothing to do with Huaguan Semiconductor, and the user shall not claim any compensation liability against Huaguan Semiconductor by the terms of this Agreement.

The technical and reliability data (including data sheets), design resources (including reference designs), application or other design suggestions, network tools, safety information and other resources provided for the performance of semiconductor products produced by Huaguan Semiconductor are not guaranteed to be free from defects and no warranty, express or implied, is made. The use of testing and other quality control technologies is limited to the quality assurance scope of Huaguan Semiconductor. Not all parameters of each device need to be tested.

The documentation of Huaguan Semiconductor authorizes you to use these resources only for developing the application of the product described in this document. You have no right to use any other Huaguan Semiconductor intellectual property rights or any third party intellectual property rights. It is strictly forbidden to make other copies or displays of these resources. You should fully compensate Huaguan Semiconductor and its agents for any claims, damages, costs, losses and debts caused by the use of these resources. Huaguan Semiconductor accepts no liability for any loss or damage caused by infringement.

单击下面可查看定价，库存，交付和生命周期等信息

[>>HGSEMI\(华冠\)](#)