

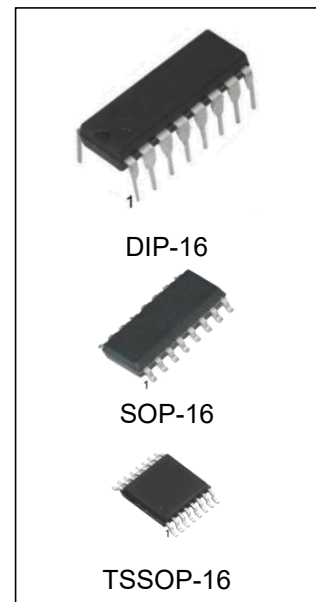
## +5V-Powered, Multichannel RS-232 Drivers / Receivers

### General Description

SP232E is purposed for application in high-performance information processing systems and control devices of wide application. Input voltage levels are compatible with standard CMOS levels.

### Features

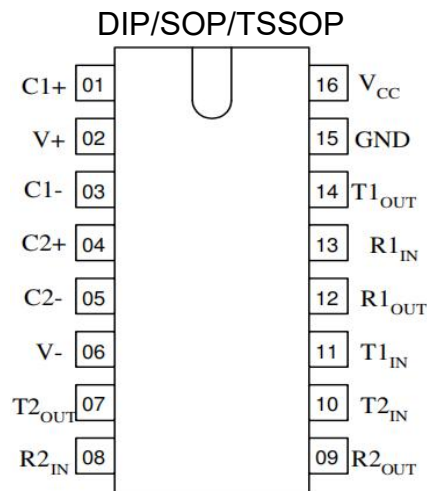
- Output voltage levels are compatible with input levels of K-MOS, N-MOS and TTL integrated circuits.
- Supply voltage : 5V
- Low input current: 1.0 $\mu$ A; 0.1 $\mu$ A at Ta= 25 °C.
- Output current 24 mA.
- Latching current not less than 450 mA at Ta= 25°C
- The transmitter outputs and receiver inputs are protected to  $\pm$ 15kV Air ESD.



### Ordering Information

DEVICE	Package Type	MARKING	Packing	Packing Qty
SP232EIN	DIP-16	SP232EI	TUBE	1000pcs/Box
SP232EIM/TR	SOP-16	SP232EI	REEL	2500pcs/Reel
SP232EIMT/TR	TSSOP-16	SP232EI	REEL	2500pcs/Reel
SP232ECN	DIP-16	SP232EC	TUBE	1000pcs/Box
SP232ECM/TR	SOP-16	SP232EC	REEL	2500pcs/Reel
SP232ECMT/TR	TSSOP-16	SP232EC	REEL	2500pcs/Reel

## Pin symbols in package



### Table of pin description

Pin No.	Symbol	Pin name
01	C1+	Output of external capacitance of positive voltage multiplier unit
02	V+	Output of positive voltage of multiplier unit
03	C1-	Output of external capacitance of positive voltage multiplier unit
04	C2+	Output of external capacitance of negative voltage multiplier unit
05	C2-	Output of external capacitance of negative voltage multiplier unit
06	V-	Output of negative voltage of multiplier unit
07	T2 <sub>OUT</sub>	Output of transmitter data (levels RS – 232)
08	R2 <sub>IN</sub>	Input of receiver data (levels RS – 232)
09	R2 <sub>OUT</sub>	Output of receiver data (levels TTL/KMOS)
10	T2 <sub>IN</sub>	Input of transmitter data (levels TTL/KMOS)
11	T1 <sub>IN</sub>	Input of transmitter data (levels TTL/KMOS)
12	R1 <sub>OUT</sub>	Output of receiver data (levels TTL/KMOS)
13	R1 <sub>IN</sub>	Input of receiver data (levels RS – 232)
14	T1 <sub>OUT</sub>	Output of transmitter data (levels RS – 232)
15	GND	Common output
16	V <sub>CC</sub>	Supply output of voltage source

**Truth table**

Inputs	Outputs
$R_{IN}, T_{IN}$	$R_{OVT}, T_{OVT}$
H	L
L	H
Note - H – voltage high level; L – low voltage level	

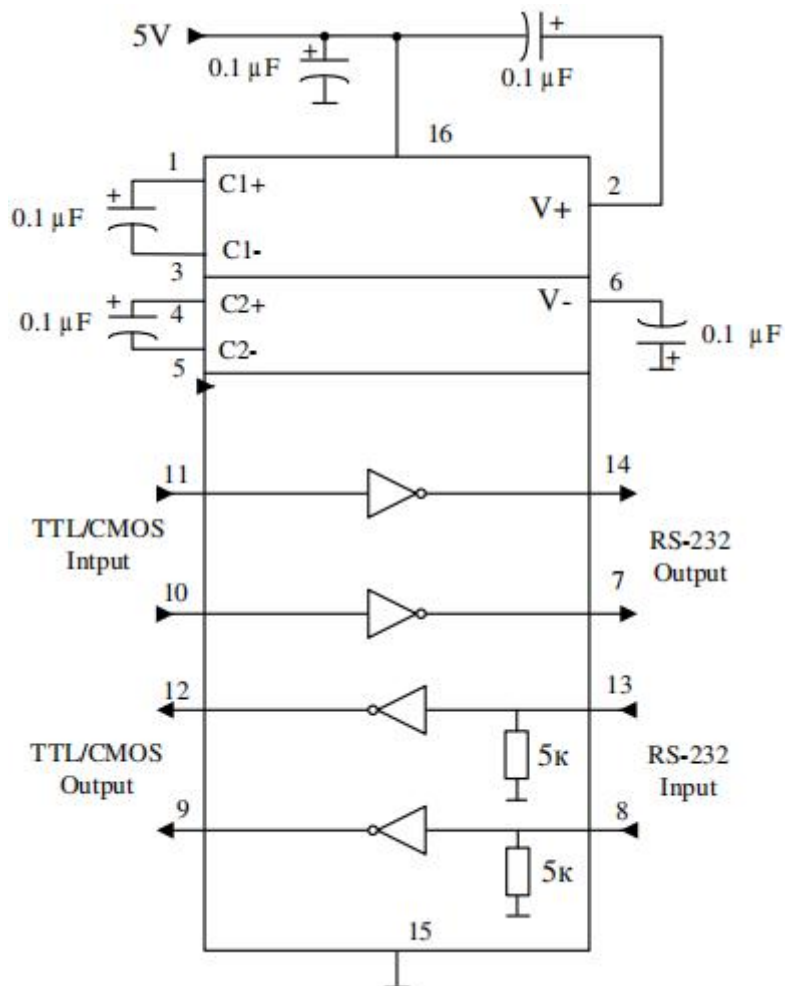
**Maximum conditions**

Symbol	Parameter	Rate		Unit
		min	max	
$V_{CC}$	Supply voltage	-0.3	6.0	V
V+	Transmitter high output voltage	$V_{CC} - 0.3$	14	
V-	Transmitter low output voltage	-0.3	-14	
$V_{TIN}$	Transmitter input voltage	-0.3	$V+ + 0.3$	
$V_{RIN}$	Receiver input voltage	-30	30	
$P_D$	Dissipated power			mW
	DIP – package SOP - package	-	842 762	
$I_{SC}$	Output current of transmitter short circuit	-	Continuously	mA
Ta	Ambient temperature	-60	150	°C
T <sub>L</sub>	Lead Temperature (Soldering, 10 seconds)	-	245	°C

**Note:** Absolute Maximum Ratings indicate limits beyond which damage to the device may occur. Operating Ratings indicate conditions for which the device is intended to be functional, but specific performance is not ensured.

**Recommended Operating Conditions**

Symbol	Parameter	Rate		Unit	
		min	max		
$V_{CC}$	Supply voltage	4.5	5.5	V	
$V_{+}$	Transmitter output high voltage	5.0	-		
$V_{-}$	Transmitter output low voltage	-5.0	-		
$V_{TIN}$	Transmitter input voltage	0	$V_{CC}$		
$V_{RIN}$	Receiver input voltage	-30	30		
$I_{SC}$	Transmitter short circuit output current	-	$\pm 60$	mA	
$T_a$	Ambient temperature	SP232EC	0	70	$^{\circ}C$
		SP232EI	-40	85	$^{\circ}C$



**Static parameters**

Symbol	Parameter	Test conditions	Rate				Unit
			25°C		-40 °C to 85 °C		
			min	max	min	max	
$I_{CC}$	Consumption current static	$V_{CC} = 5.0V$ $V_{IL} = 0V$	-	10.0	-	14.0	mA
<b>Receiver electrical parameters</b>							
$V_h$	Hysteresis voltage	$V_{CC} = 5.0V$	0.2	0.9	0.2	1.0	V
$V_{On}$	On (operation) voltage	$V_O \leq 0.1V$ $I_{OL} \leq 20 \mu A$	-	2.4	-	2.3	
$V_{off}$	Off (dropout) voltage	$V_O \geq V_{CC} - 0.1V$ $I_{OH} \leq -20 \mu A$	0.8	-	0.9	-	
$V_{OL}$	Output low voltage	$I_{OL} = 3.2 mA$ $V_{CC} = 4.5 V$ $V_{IH} = 2.4 V$	-	0.3	-	0.4	
$V_{OH}$	Output high voltage	$I_{OH} = -1.0 mA$ $V_{CC} = 4.5 V$ $V_{IL} = 0.8 V$	3.6	-	3.5	-	
$R_i$	Input resistance	$V_{CC} = 5.0 V$	3.0	7.0	3.0	7.0	kOhm
<b>Transmitter electrical parameters</b>							
$V_{OL}$	Output low voltage	$V_{CC} = 4.5 V$ $V_{IH} = 2.0 V$ $R_L = 3.0 kOhm$	-	-5.2	-	-5.0	V
$V_{OH}$	Output high voltage	$V_{CC} = 4.5 V$ $V_{IL} = 0.8 V$ $R_L = 3.0 kOhm$	5.2	-	5.0	-	
$I_{IL}$	Input low current	$V_{CC} = 5.5 V$ $V_{IL} = 0 V$	-	-1.0	-	-10.0	uA
$I_{IH}$	Input high current	$V_{CC} = 5.5 V$ $V_{IH} = V_{CC}$		1.0		10.0	
SR	Speed of output front change	$V_{CC} = 5.0 V$ $C_L = 50 - 1000 pF$ $R_L = 3.0 - 7.0 kOhm$	3.0	30	2.7	27	V/ $\mu s$
$R_o$	Output resistance	$V_{CC} = V_+ = V_- = 0 V$ $V_O = \pm 2 V$	350	-	300	-	Ohm
$I_{SC}$	Short circuit output current	$V_{CC} = 5.5 V$ $V_O = 0 V$ $V_I = V_{CC}$ $V_I = 0 V$		-50 50		-60 60	mA
ST	Speed of information transmission	$V_{CC} = 4.5 V$ $C_L = 1000 pF$ $R_L = 3.0 kOhm$ $t_W = 7 \mu s$ (for extreme $-t_W = 8 \mu s$ )	140	-	120	-	

**Dynamic parameters**

Symbol	Parameter	Test conditions	Rate				Unit
			25°C		from -40°C to 85°C		
			min	max	min	max	
t <sub>PHLR</sub> (t <sub>PLHR</sub> )	Signal propagation delay time when switching on (off)	V <sub>CC</sub> = 4.5 V C <sub>L</sub> = 150 pF V <sub>IL</sub> = 0 V V <sub>IH</sub> = 3.0 V t <sub>LH</sub> = t <sub>HL</sub> ≤ 10 ns	-	9.7	-	10	us
t <sub>phlt</sub> (t <sub>PLHT</sub> )	Signal propagation delay time when switching on (off)	V <sub>CC</sub> = 4.5 V C <sub>L</sub> = 2500 pF V <sub>IL</sub> = 0 V V <sub>IH</sub> = 3.0 V R <sub>L</sub> = 3 kOhm t <sub>LH</sub> = t <sub>HL</sub> ≤ 10 ns		5.0*		6.0*	

**Capacitance**

Symbol	Parameter	V <sub>CC</sub>	Rate	Unit
C <sub>IN</sub>	Input capacitance	5.0	9.0	pF
CPD	Dynamic capacitance		90	

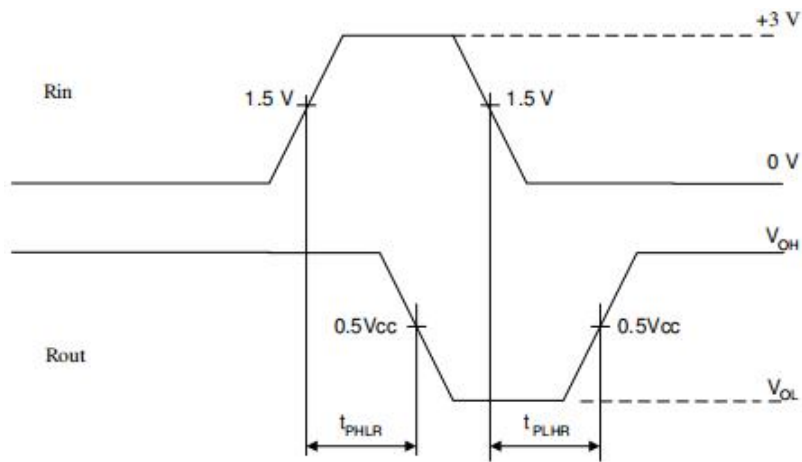
**Timing diagram when measuring IC dynamic parameters**


Figure 3

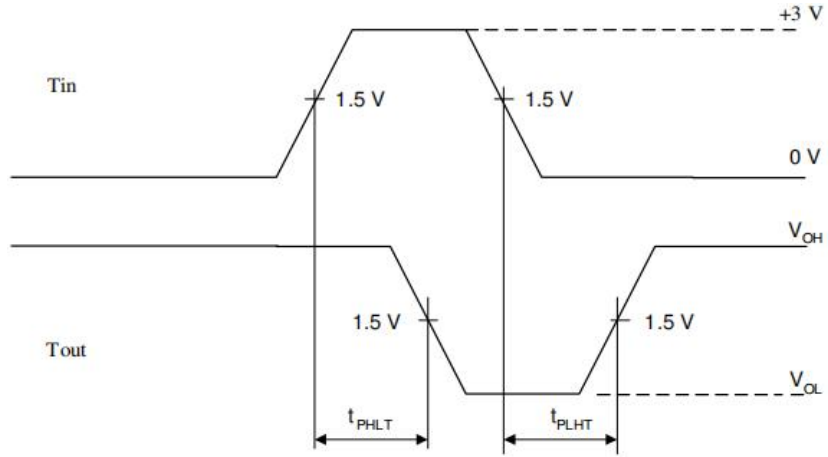


Figure 4

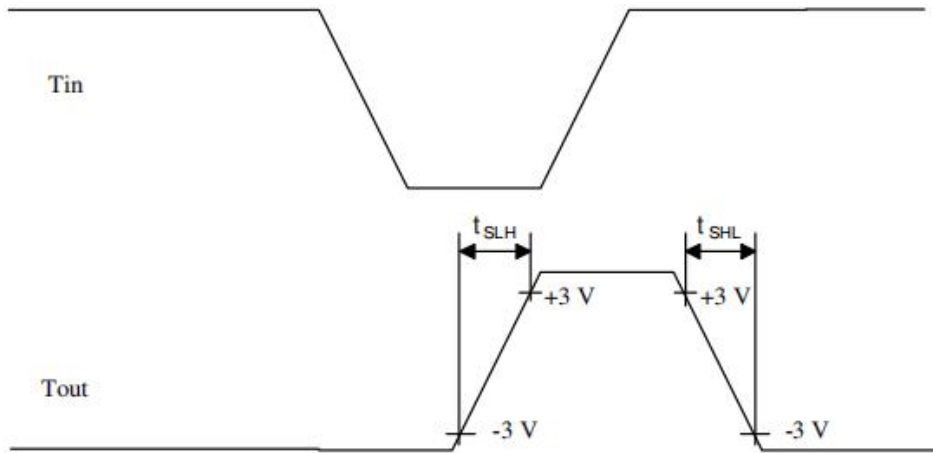


Figure 5

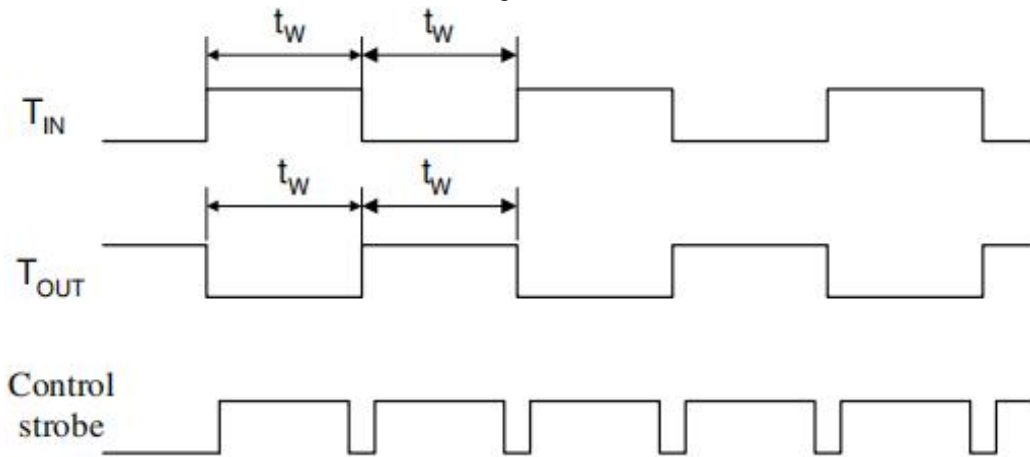
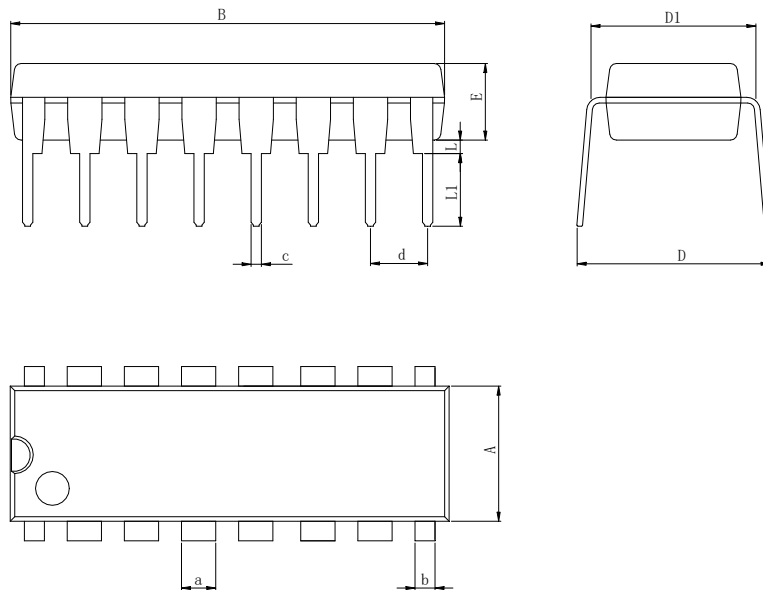
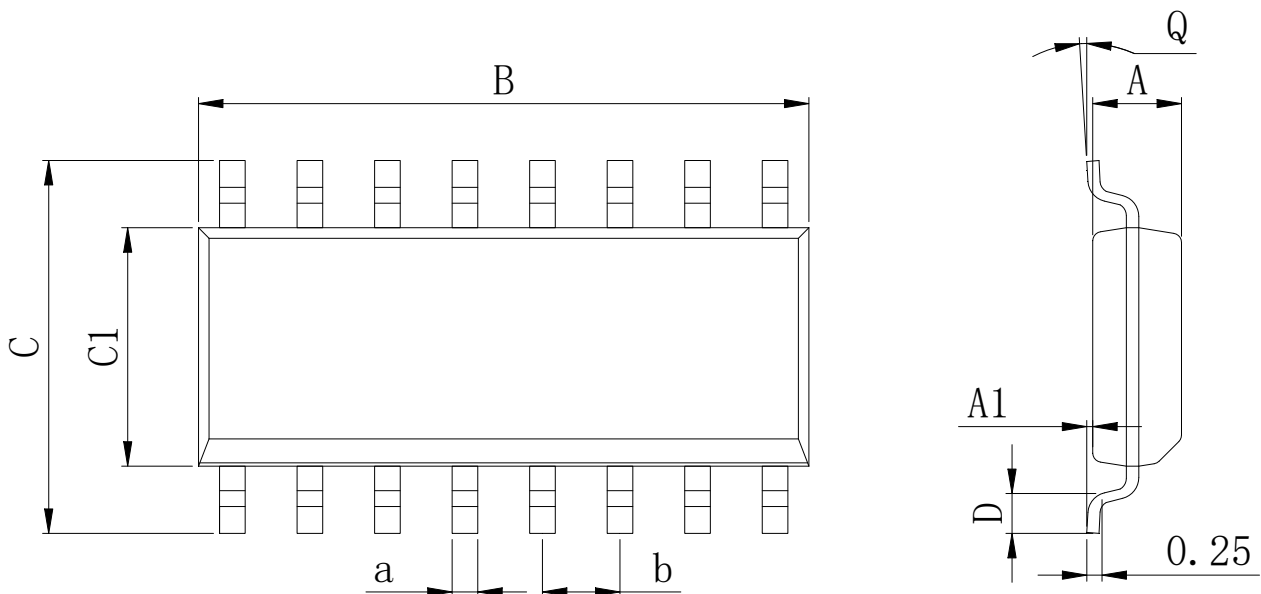


Figure 6

**Physical Dimensions**
**DIP-16**

**Dimensions In Millimeters(DIP-16)**

Symbol:	A	B	D	D1	E	L	L1	a	b	c	d
Min:	6.10	18.94	8.10	7.42	3.10	0.50	3.00	1.50	0.85	0.40	2.54 BSC
Max:	6.68	19.56	10.9	7.82	3.55	0.70	3.60	1.55	0.90	0.50	

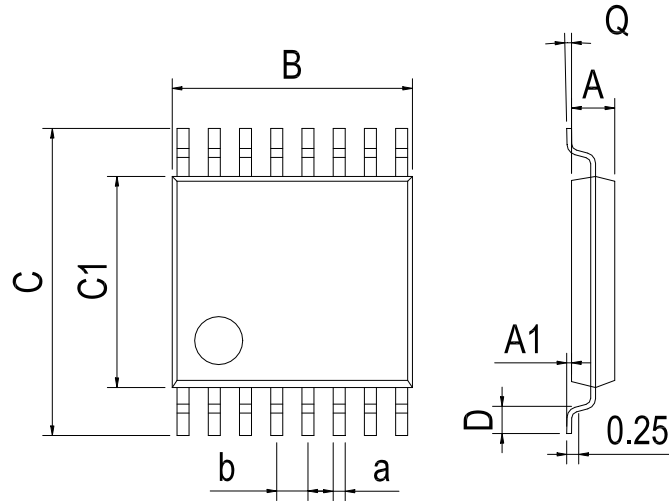
**SOP-16**

**Dimensions In Millimeters(SOP-16)**

Symbol:	A	A1	B	C	C1	D	Q	a	b
Min:	1.35	0.05	9.80	5.80	3.80	0.40	0°	0.35	1.27 BSC
Max:	1.55	0.20	10.0	6.20	4.00	0.80	8°	0.45	



**Physical Dimensions**

TSSOP-16



Dimensions In Millimeters(TSSOP-16)									
Symbol:	A	A1	B	C	C1	D	Q	a	b
Min:	0.85	0.05	4.90	6.20	4.30	0.40	0°	0.20	0.65 BSC
Max:	0.95	0.20	5.10	6.60	4.50	0.80	8°	0.25	

## Revision History

DATE	REVISION	PAGE
2018-8-12	New	1-11
2023-9-14	Modify the package dimension diagram TSSOP-16、 Update encapsulation type、 Update Lead Temperature、 Updated DIP-16 dimension、 Add annotation for Maximum Ratings.	1、 3、 8、 9

**IMPORTANT STATEMENT:**

Huaguan Semiconductor reserves the right to change its products and services without notice. Before ordering, the customer shall obtain the latest relevant information and verify whether the information is up to date and complete. Huaguan Semiconductor does not assume any responsibility or obligation for the altered documents.

Customers are responsible for complying with safety standards and taking safety measures when using Huaguan Semiconductor products for system design and machine manufacturing. You will bear all the following responsibilities: Select the appropriate Huaguan Semiconductor products for your application; Design, validate and test your application; Ensure that your application meets the appropriate standards and any other safety, security or other requirements. To avoid the occurrence of potential risks that may lead to personal injury or property loss.

Huaguan Semiconductor products have not been approved for applications in life support, military, aerospace and other fields, and Huaguan Semiconductor will not bear the consequences caused by the application of products in these fields. All problems, responsibilities and losses arising from the user's use beyond the applicable area of the product shall be borne by the user and have nothing to do with Huaguan Semiconductor, and the user shall not claim any compensation liability against Huaguan Semiconductor by the terms of this Agreement.

The technical and reliability data (including data sheets), design resources (including reference designs), application or other design suggestions, network tools, safety information and other resources provided for the performance of semiconductor products produced by Huaguan Semiconductor are not guaranteed to be free from defects and no warranty, express or implied, is made. The use of testing and other quality control technologies is limited to the quality assurance scope of Huaguan Semiconductor. Not all parameters of each device need to be tested.

The documentation of Huaguan Semiconductor authorizes you to use these resources only for developing the application of the product described in this document. You have no right to use any other Huaguan Semiconductor intellectual property rights or any third party intellectual property rights. It is strictly forbidden to make other copies or displays of these resources. You should fully compensate Huaguan Semiconductor and its agents for any claims, damages, costs, losses and debts caused by the use of these resources. Huaguan Semiconductor accepts no liability for any loss or damage caused by infringement.

单击下面可查看定价，库存，交付和生命周期等信息

[>>HGSEMI\(华冠\)](#)