

## DC TO DC CONVERTER CONTROLLER

### ■ DESCRIPTION

The HG MC34063 is a monolithic regulator subsystem, intended for use as DC to DC converter. This device contains a temperature compensated band gap reference, a duty-cycle control oscillator, driver and high current output switch. It can be used for step down, step-up or inverting switching regulators as well as for series pass regulators.

### ■ FEATURES

- \* Operation from 3.0V to 40V.
- \* Short circuit current limiting.
- \* Low standby current.
- \* Output switch current of 1.5A without external transistors.
- \* Frequency of operation from 100Hz to 100kHz.
- \* Step-up, step-down or inverting switch regulators.

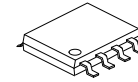

SOP-8

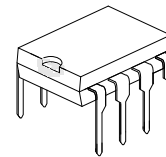

DIP-8

### ■ PIN CONFIGURATION

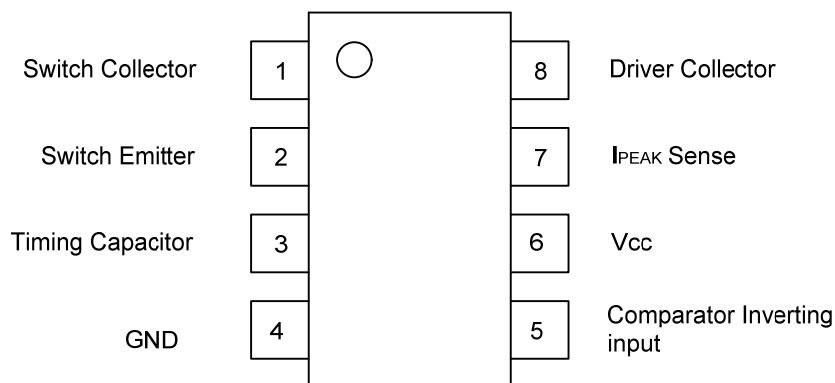

### ■ PIN DESCRIPTION

PIN NO	PIN NAME	I/O	DESCRIPTION
1	Switch Collector	I	Internal Darlington pairs T1 collector
2	Switch Emitter	O	Internal Darlington pairs T1 emitter
3	Timing Capacitor		The value of selected capacitor controls the internal oscillator run rate
4	GND		
5	Comparator Inverting Input	I	Inverting input of comparator which can set & initiate the Darlington pairs output switch
6	V <sub>CC</sub>		
7	I <sub>PEAK</sub> Sense	I	Current sense input to monitor the voltage drop across an external resistor placed in series with V <sub>CC</sub>
8	Driver Collector	I	Internal Darlington pairs T1 collector

■ BLOCK DIAGRAM

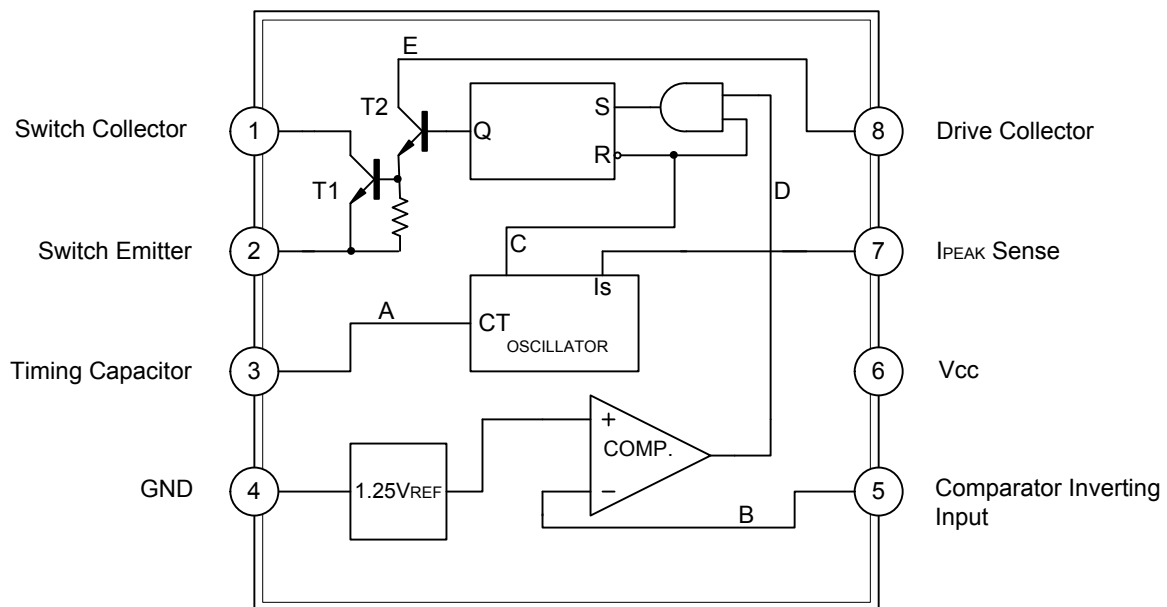

■ ABSOLUTE MAXIMUM RATINGS (Ta=25°C)

PARAMETER	SYMBOL	RATINGS	UNIT
Supply Voltage	$V_{CC}$	40	V
Comparator Input Voltage Range	$V_{IN(COMP)}$	-0.3 ~ +40	V
Switch Collector Voltage	$V_{C(SW)}$	40	V
Switch Emitter Voltage	$V_{E(SW)}$	40	V
Switch Collector to Emitter Voltage	$V_{CE(SW)}$	40	V
Driver Collector Voltage	$V_{C(DR)}$	40	V
Switch Current	$I_{SW}$	1.5	A
Power Dissipation (Ta=25°C)	DIP-8	1250	mW
	SOP-8	625	
Junction Temperature	$T_J$	+150	°C
Operating Temperature	$T_{OPR}$	0 ~ +70	°C
Storage Temperature	$T_{STG}$	-65 ~ +150	°C

Note: Absolute maximum ratings are those values beyond which the device which the device could be permanently damaged. Absolute maximum ratings are stress ratings only and functional device operation is not implied.

■ THERMAL DATA

PARAMETER	SYMBOL	RATINGS	UNIT
Junction-to-Ambient	DIP-8	100	°C/W
	SOP-8	160	

■ ELECTRICAL CHARACTERISTICS ( $V_{CC}=5.0V$ ,  $T_a=0\sim+70^{\circ}C$ , unless otherwise specified.)

PARAMETER	SYMBOL	TEST CONDITIONS	MIN	TYP	MAX	UNIT
<b>Oscillator</b>						
Charging Current	$I_{CHG}$	$V_{CC}=5$ to $40V$ , $T_a=25^{\circ}C$	22	31	42	$\mu A$
Discharging Current	$I_{DISCHG}$	$V_{CC}=5$ to $40V$ , $T_a=25^{\circ}C$	140	190	260	$\mu A$
Oscillator Amplitude	$V_{OSC}$	$T_a=25^{\circ}C$		0.5		V
Discharge to Charge Current Ratio	K	$V_7=V_{CC}$ , $T_a=25^{\circ}C$	5.2	6.1	7.5	
Current limit Sense Voltage	$V_{SENSE}$	$I_{CHG}=I_{DISCHG}$ , $T_a=25^{\circ}C$	250	300	350	mV
<b>Output Switch</b>						
Saturation Voltage 1(Note)	$V_{CE(SAT)1}$	$I_{SW}=1.0A$ , $V_{C(DRIVER)}=V_{C(SW)}$		0.95	1.3	V
Saturation Voltage 2(Note)	$V_{CE(SAT)2}$	$I_{SW}=1.0A$ , $V_{C(DRIVER)}=50mA$		0.45	0.7	V
DC Current Gain(Note)	$G_{I(DC)}$	$I_{SW}=1.0A$ , $V_{CE}=5.0V$ , $T_a=25^{\circ}C$	50	180		
Collector Off State Current(Note)	$I_{C(OFF)}$	$V_{CE}=40.0V$ , $T_a=25^{\circ}C$		0.01	100	$\mu A$
<b>Comparator</b>						
Threshold Voltage	$V_{THD}$		1.21	1.24	1.29	V
Threshold Voltage Line Regulation	$V_{THD}$	$V_{CC}=3 \sim 40V$		2.0	5.0	mV
Input Bias Current	$I_{I(BIAS)}$	$V_{IN}=0V$		50	400	nA
<b>Total Device</b>						
Supply Current	$I_{CC}$	$V_{CC}=5\sim40V$ , $C_T=0.001$ $V_7=V_{CC}$ , $V_C>V_{THD}$ , $Pin2=GND$		2.7	4.0	mA

Note: Output switch tests are performed under pulsed conditions to minimize power dissipation.

■ STEP-UP CONVERTER(Cont.)

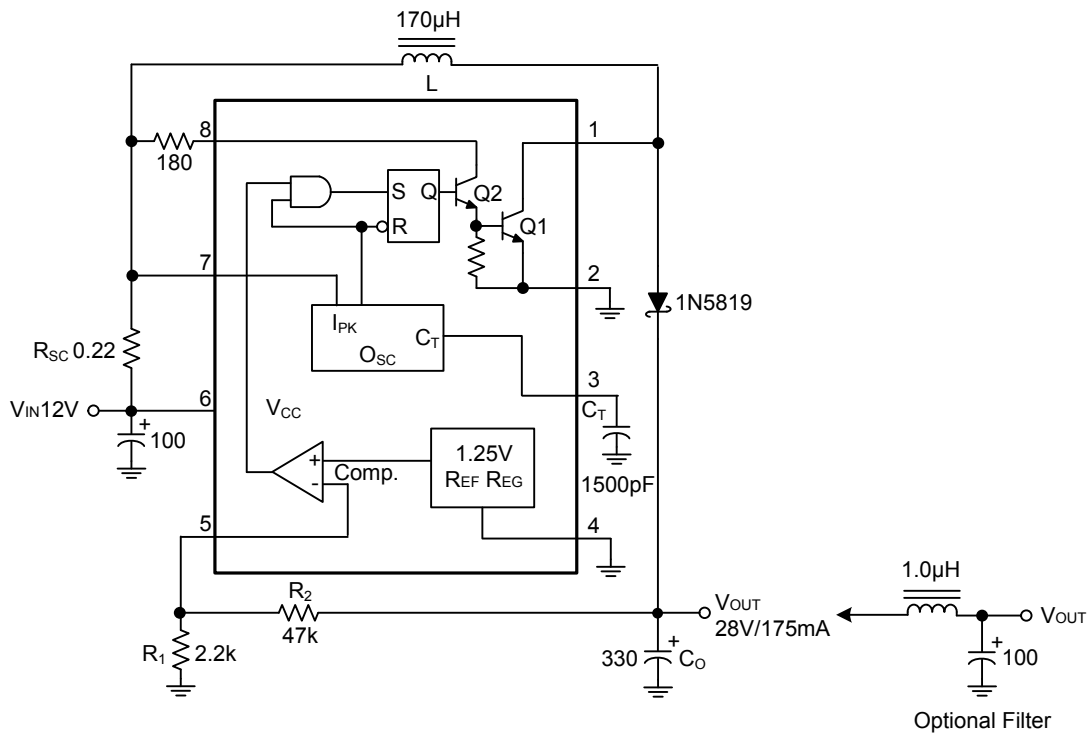

■ STEP-DOWN CONVERTER(Cont.)

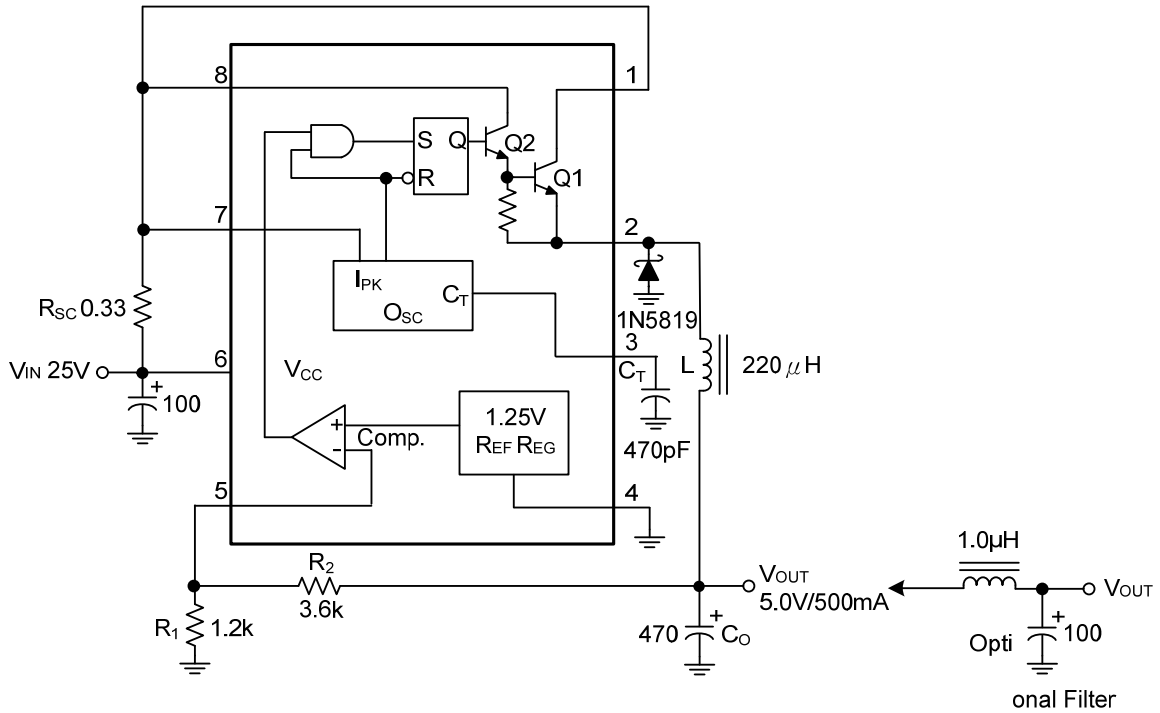

■ VOLTAGE INVERTING CONVERTER

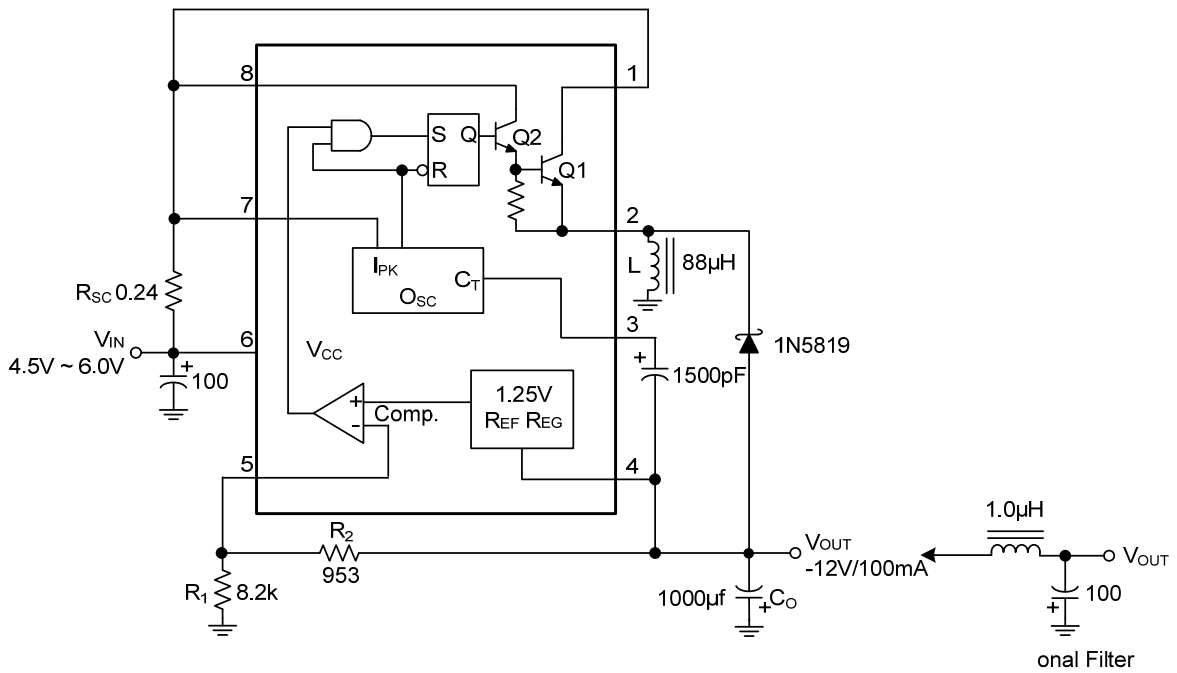

■ DESIGN FORMULA TABLE

CALCULATION	STEP-DOWN	STEP-UP	VOLTAGE-INVERTING
$\frac{t_{ON}}{t_{OFF}}$	$\frac{V_{OUT} + V_F}{V_{IN(MIN)} - V_{CE(SAT)} - V_{OUT}}$	$\frac{V_{OUT} + V_F - V_{IN(MIN)}}{V_{IN(MIN)} - V_{CE(SAT)}}$	$\frac{ V_{OUT}  + V_F}{V_{IN} - V_{CE(SAT)}}$
$(t_{ON} + t_{OFF})_{MAX}$	$\frac{1}{F_{MIN}}$	$\frac{1}{F_{MIN}}$	$\frac{1}{F_{MIN}}$
$C_T$	$4 \times 10^{-5} t_{ON}$	$4 \times 10^{-5} t_{ON}$	$4 \times 10^{-5} t_{ON}$
$I_{SW}$	$2I_{OUT(MAX)}$	$2I_{OUT(MAX)} \frac{t_{ON} + t_{OFF}}{t_{OFF}}$	$2I_{OUT(MAX)} \frac{t_{ON} + t_{OFF}}{t_{OFF}}$
$R_S$	$0.3/I_{SW}$	$0.3/I_{SW}$	$0.3/I_{SW}$
$L_{(MIN)}$	$(\frac{V_{IN(MIN)} - V_{CE(SAT)} - V_{OUT}}{I_{SW}}) t_{ON(MAX)}$	$(\frac{V_{IN(MIN)} - V_{CE(SAT)}}{I_{SW}}) t_{ON(MAX)}$	$(\frac{V_{IN(MIN)} - V_{CE(SAT)}}{I_{SW}}) t_{ON(MAX)}$
$C_O$	$\frac{I_{SW}(t_{ON} + t_{OFF})}{8V_{RIPPLE(P-P)}}$	$\frac{I_{OUT} t_{ON}}{V_{RIPPLE(P-P)}}$	$\frac{I_{OUT} t_{ON}}{V_{RIPPLE(P-P)}}$

$V_{CE(SAT)}$  - Saturation voltage of the output switch.

$V_F$  - Forward voltage drop of the ringback rectifier.

**The following power supply characteristics must be chosen:**

$V_{IN}$  - Nominal input voltage.

$V_{OUT}$  - Desired output voltage,  $|V_{OUT}| = 1.25(1 + R_2/R_1)$

$I_{OUT}$  - Desired output current.

$F_{MIN}$  - Minimum desired output switching frequency at the selected values for  $V_{IN}$  and  $I_{OUT}$ .

$V_{RIPPLE(P-P)}$  - Desired peak-to-peak output ripple voltage. In practice, the calculated value will need to be increased due to the capacitor equivalent series resistance and board layout. The ripple voltage should be kept to a low value since it will directly effect the line and load regulation.

■ TYPICAL CHARACTERISTICS

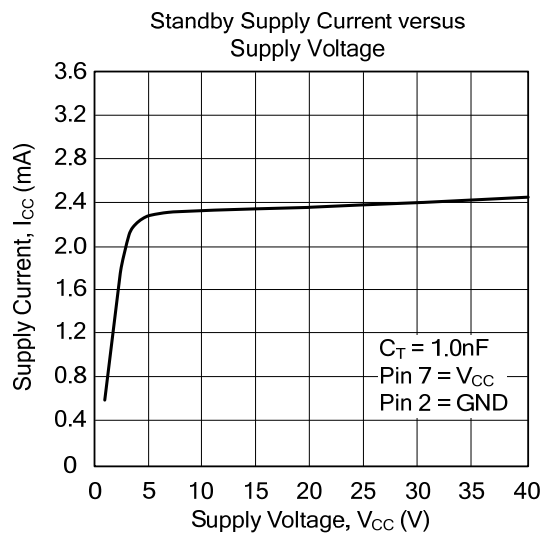
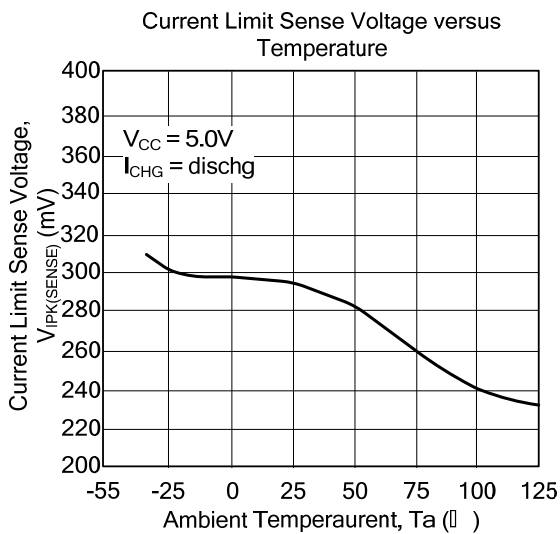
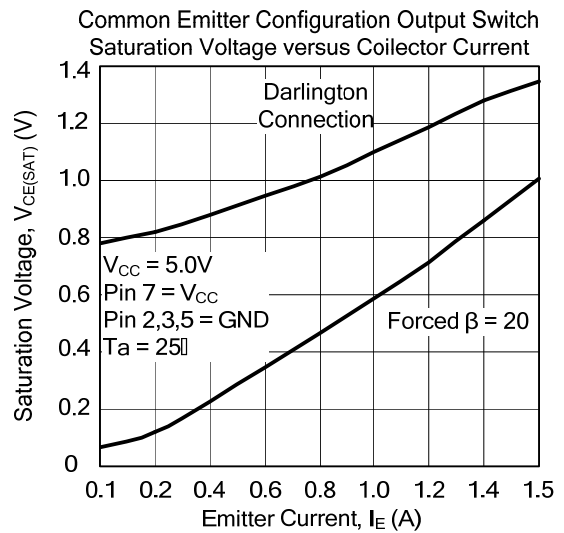
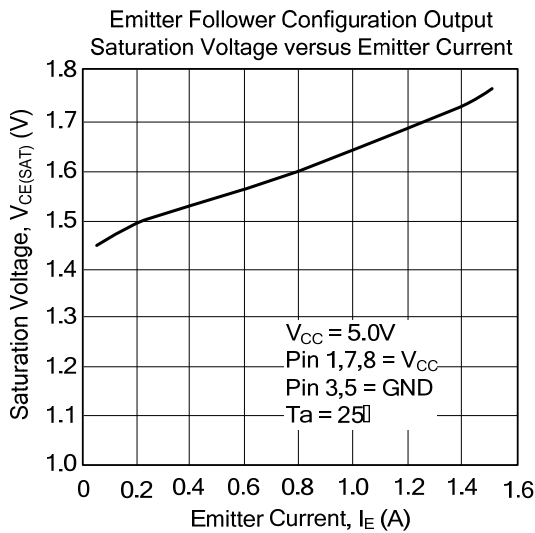
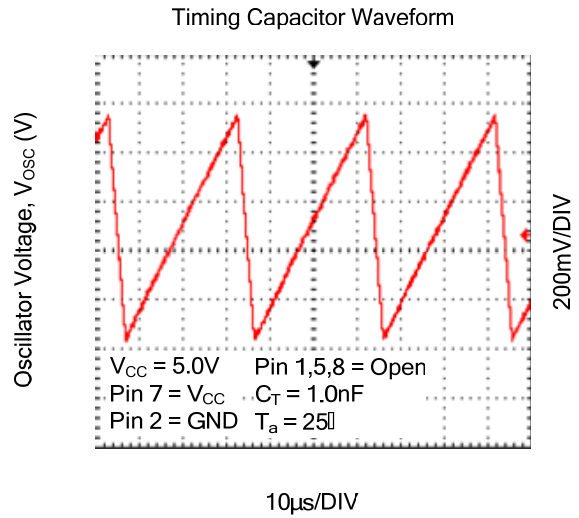
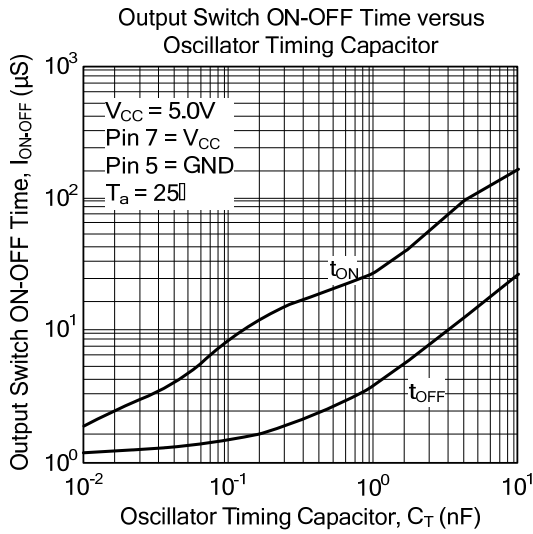

单击下面可查看定价，库存，交付和生命周期等信息

[>>HGSEMI\(华冠\)](#)