 Hollyland (China) Electronics Technology Corporation Ltd. Hollyland(XiaMen) Technology Corporation Ltd.	<b>PRODUCT SPECIFICATION</b>	ISSUED DATE:	2020/08/04
	<b>6FF(P) RoHS SERIES</b>	REV. NO.:	A06
		DOC. NO.:	HLD-PSI-8004
		PAGE:	Page 1 of 9

制定 PREPARED BY		审核 CHECKED BY		批准 APPROVED BY	
-------------------	---	------------------	---	-------------------	---

### 1 适用范围/ SCOPE

本规格书适用于公司生产并获得 TUV 安全标准认证的 6FF(P) RoHS 系列 HOLLY® 商标的小型特快熔断型保险丝管。

This specification defines the technical requirements of miniature and very fast-acting fuse type 6FF(P) RoHS series with HOLLY® brand, which are approved by TUV.

产品部件号为:                     型号                     额定电流                     额定电压  
Construction of part no.:          type                     rated current                     rated voltage  
例如/ Example:    6FF(P)            010            H<sub>1</sub>

\* 额定电压/ Rated Voltage: H<sub>1</sub>-1000V<sub>ac</sub> H<sub>2</sub> - 500V<sub>ac</sub> H<sub>3</sub> - 600V<sub>ac</sub> H<sub>4</sub> -1000V<sub>dc</sub>

### 产品部件号/ PART NUMBER

PART NUMBER	额定电流 RATED CURRENT	额定电压 RATED VOLTAGE	PART NUMBER	额定电流 RATED CURRENT	额定电压 RATED VOLTAGE
6FF(P)-0200H <sub>1</sub> /H <sub>4</sub>	200 mA	1000V <sub>ac/dc</sub>	6FF(P)-025H <sub>2</sub> /H <sub>3</sub>	2.5 A	500V <sub>ac</sub> /600V <sub>ac</sub>
6FF(P)-0250H <sub>1</sub> /H <sub>4</sub>	250 mA		6FF(P)-030H <sub>2</sub> /H <sub>3</sub>	3.0 A	
6FF(P)-0300H <sub>1</sub> /H <sub>4</sub>	300 mA		6FF(P)-032H <sub>2</sub> /H <sub>3</sub>	3.15 A	
6FF(P)-0315H <sub>1</sub> /H <sub>4</sub>	315 mA		6FF(P)-035H <sub>2</sub> /H <sub>3</sub>	3.5 A	
6FF(P)-0350H <sub>1</sub> /H <sub>4</sub>	350 mA		6FF(P)-040H <sub>2</sub> /H <sub>3</sub>	4.0 A	
6FF(P)-0375H <sub>1</sub> /H <sub>4</sub>	375 mA		6FF(P)-050H <sub>2</sub> /H <sub>3</sub>	5.0 A	
6FF(P)-0400H <sub>1</sub> /H <sub>4</sub>	400 mA		6FF(P)-060H <sub>2</sub> /H <sub>3</sub>	6.0 A	
6FF(P)-0500H <sub>1</sub> /H <sub>4</sub>	500 mA		6FF(P)-063H <sub>2</sub> /H <sub>3</sub>	6.3 A	
6FF(P)-0600H <sub>1</sub> /H <sub>4</sub>	600 mA		6FF(P)-070H <sub>2</sub> /H <sub>3</sub>	7.0 A	
6FF(P)-0630H <sub>1</sub> /H <sub>4</sub>	630 mA		6FF(P)-080H <sub>2</sub> /H <sub>3</sub>	8.0 A	
6FF(P)-0700H <sub>1</sub> /H <sub>4</sub>	700 mA		6FF(P)-090H <sub>2</sub> /H <sub>3</sub>	9.0 A	
6FF(P)-0750H <sub>1</sub> /H <sub>4</sub>	750 mA		6FF(P)-100H <sub>2</sub> /H <sub>3</sub>	10 A	
6FF(P)-0800H <sub>1</sub> /H <sub>4</sub>	800 mA		6FF(P)--125H <sub>2</sub>	12.5 A	
6FF(P)-010H <sub>1</sub> /H <sub>4</sub>	1.0 A		6FF(P)--160H <sub>2</sub>	16 A	
6FF(P)-012H <sub>1</sub> /H <sub>4</sub>	1.2 A		6FF(P)--200H <sub>2</sub>	20 A	
6FF(P)-013H <sub>1</sub> /H <sub>4</sub>	1.25 A		6FF(P)--250H <sub>2</sub>	25 A	
6FF(P)-015H <sub>1</sub> /H <sub>4</sub>	1.5 A		6FF(P)--300H <sub>2</sub>	30 A	
6FF(P)-016H <sub>1</sub> /H <sub>4</sub>	1.6 A				
6FF(P)-020H <sub>1</sub> /H <sub>4</sub>	2.0 A				

### 2 相关标准/ APPLICABLE STANDARDS

2.1 6FF(P) RoHS 系列产品适用的相关标准是 IEC60127。

Applicable standard for 6FF(P) RoHS series is IEC60127.

### 2.2 认证情况/ APPROVED DETAILS

额定电压 RATED VOLTAGE	TUV		UR/CUR	
	认证范围 APPROVED RANGE	认证号码 CERT. NO.	认证范围 APPROVED RANGE	认证号码 CERT. NO.
1000V <sub>ac</sub>	200mA~2A	J50139804	200mA~2A(1000V <sub>ac/dc</sub> )	E156471
500V <sub>ac</sub> /600V <sub>ac</sub>	2.5A~10A		/	

### 3 公司地址/ ADDRESS

中国福建省厦门市翔安区舫山东二路 829 号

829 Fangshan East 2nd Road, Xiang'an, Xiamen, China.

 Hollyland (China) Electronics Technology Corporation Ltd. Hollyland(XiaMen) Technology Corporation Ltd.	<b>PRODUCT SPECIFICATION</b>	ISSUED DATE: 2020/08/04
	<b>6FF(P) RoHS SERIES</b>	REV. NO.: A06 DOC. NO.: HLD-PSI-8004 PAGE: Page 2 of 9

#### 4 构造图/ CONSTRUCTION FIG. & DIMENSION

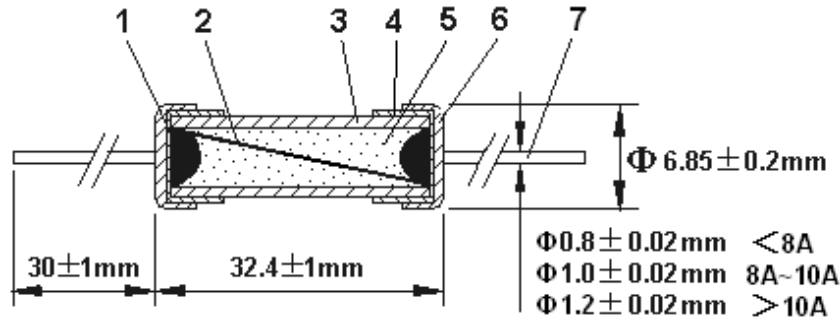

编号 No.	品名 PART	材料名 MATERIAL MODEL	备注 NOTE
1	焊锡 Solder	无铅焊锡/ Pb Free	额定电流 $I_n < 8A$
		含铅高温焊锡/ Pb Contained High Temperature Solder	额定电流 $I_n \geq 8A$
2	可熔体 Element	金属丝/ Metal Wire	额定电流 $I_n < 8A$
		金属片/ Metal Strip	额定电流 $I_n \geq 8A$
3	管体/ Tube	陶瓷管/ Ceramic Tube	/
4	填充物/ Filler	石英砂/ Quartz Sand	/
5	铜帽/ Cap	黄铜/ Brass	镀镍/ Nickel Plated
6	尾线铜帽 Cap with Lead	黄铜 Brass	镀镍 Nickel Plated
7	尾线/ Pig Tail	镀锡铜线/ Tin Plated Copper	镀锡/ Tin Plated

##### 4.1 陶瓷管/ CERAMIC TUBE

陶瓷管必须无缺陷破裂和缺损。

The ceramic tube shall have no defects such as crack and injury.

##### 4.2 铜帽/ CAP

铜帽应焊接牢固，以保证在未损坏熔断体时，铜帽不能被卸脱。样品在 15℃-35℃ 水中浸 24 小时取出后，在每个端帽上，均匀地施加拉力至 10N，保持 1 分钟，铜帽不应脱落。

Cap should be firmly attached so that it is not possible to remove them without damaging the fuse itself. The samples are immersed in water for 24 hours at a temperature between 15℃ and 35℃. After remove from the water, an axial pull steadily increasing to 10N is applied to each cap for 1 minute.

##### 4.3 焊点/ SOLDERING JOINT

焊接铜帽端时，铜帽外表面不能有残留的助焊剂、焊锡、可熔体等异物。

Soldering joint in end cap shall not be melted during normal operation and shall not have solder chips on tube, element in view and outer surface of caps.

#### 5 机械特性/ MECHANICAL PERFORMANCES

保险丝应能承受下列三项试验。/ Fuse shall be withstood following three testing.

##### 5.1 扭力试验/ Rotational Strength

固定保险丝的一端铜帽，然后在另一端铜帽上顺时针和逆时针方向上顺序施加 50N·mm 力矩，两端铜帽不应松动，管体也不应破碎。

When one end cap of the specimen is fixed and then the torque 50N·mm is applied to the other end cap clockwise and counterclockwise, no looseness of end caps at both ends or damage of fuse-tube shall occur.

##### 5.2 拉力试验/ Tensile Strength

固定保险丝的一端铜帽，然后在另一端铜帽上，沿水平轴方向施加 10N 的拉力，两端铜帽不应松动且管体不应破碎。

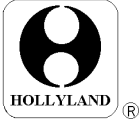
 Hollyland (China) Electronics Technology Corporation Ltd. Hollyland(XiaMen) Technology Corporation Ltd.	<b>PRODUCT SPECIFICATION</b>	ISSUED DATE:	2020/08/04
	<b>6FF(P) RoHS SERIES</b>	REV. NO.:	A06
		DOC. NO.:	HLD-PSI-8004
		PAGE:	Page 3 of 9

When one end cap of the specimen is fixed and then the tensile force 10N is applied to the other end cap in a direction to separate the end caps, no looseness of end caps or damage of fuse-tube shall occur.

### 5.3 管体强度试验/ Strength of Fuse-tube

两端铜帽固定好后，在陶瓷管的中心位置施加 30N 的压力，管体不应破碎。

When middle parts of end caps at both ends of the specimen are supported and then the force 30N is applied to the middle part of the fuse-tube, no damage of the fuse-tube shall occur.

## 6 电气特性/ ELECTRICAL PERFORMANCE

### 6.1 测试条件/ TEST CONDITION

全部测试条件都应在环境温度  $24^{\circ}\text{C} \pm 3^{\circ}\text{C}$  条件下进行，在此期间温度变化不允许达到  $+5^{\circ}\text{C}$  和到极限范围

All electrical tests are conducted at an ambient temperature of  $24 \pm 3^{\circ}\text{C}$ . The ambient temperature is not allowed to vary more than  $5^{\circ}\text{C}$  during the test, and must be within these limits.

### 6.2 负载能力测试/ CURRENT-CARRYING CAPACITY TEST

当保险丝通以 100% 倍额定电流的条件下进行测试时，在 1 小时内电路不应断开，保险丝不被电流熔化，管体不破裂。

When a fuse is carrying 100% of rated current for continuing 1 hours and more, no open circuit, melt fusible element, or ruptured tube shall occur in any manner during this test.

### 6.3 温度上升试验/ TEMPERATURE RISE TEST

当保险丝通以 100% 倍额定电流的条件下进行测试时，在达到热量平衡后，测量保险丝表面的温度，保险丝表面的温度上升必须等于或低于  $130^{\circ}\text{C}$ 。注：温度上升=保险丝表面的温度-环境温度。

Measure the temperature of the surface of the fuse under the 100% rated current, when the thermal equilibrium reaches. The temperature rise on the surface of each fuse shall be  $130^{\circ}\text{C}$  or less.

Note: Temp. rise = fuse temp. - room temp..

### 6.4 预飞弧时间-电流特性/ PRE-ARCING TIME-CURRENT CHARACTERISTICS

当保险丝通以下表规定的电流时，其熔断时间必须符合下表的要求，且铜帽不能飞脱、管体不应破裂、损坏。

When the current in the following table is passing the fuse, its opening time must be in accordance with the requirements in the following table, that is, the pre-arcing time. Moreover, neither damage of the fuse-tube nor shattering of the cap shall occur.

额定电流 Rated Current	2.1In	2.75In		4In	10In
	Max.	Min.	Max.	Max.	Max.
<1A	-	-		60ms	6ms
1A~10A	30min.	5ms	1sec		
>10A~16A	30min.	10ms	2sec	100ms	10ms
>16A~25A	30min.	10ms	5sec	200ms	10ms
>25A	30min.	10ms	5sec	300ms	10ms

### 6.5 分断能力/ BREAKING CAPACITY

这些型号的保险丝的分断能力应能达到下表规定的相应的各种安全认证的分断能力要求。保险丝分断电路后，保险丝管不应破裂、铜帽飞脱、且铜帽两端的绝缘电阻不小于  $0.1\text{M}\Omega$ 。

The breaking capacity should reach the interrupting rated current given in the following table. And after this test, there should be no damage of the fuse-tube or shattering of the caps. After this test, the insulation resistance between the end caps shall be not less than  $0.1\text{M}\Omega$ .

额定电压 RATED VOLTAGE	额定电流 RATED CURRENT	分断电流/ BREAKING CURRENT		
		TUV	UR/cUR	实际分断能力 Actual Breaking Capacity
1000V <sub>ac</sub>	200mA~2A	10,000A	10,000A(1000V <sub>ac/dc</sub> )	50kA(1000V <sub>ac/dc</sub> ), Time Constant $\leq 1\text{ms}$ .
500V <sub>ac</sub> / 600V <sub>ac</sub>	2.5A~10A		/	/



Hollyland (China) Electronics  
Technology Corporation Ltd.  
Hollyland(XiaMen)  
Technology Corporation Ltd.

**PRODUCT SPECIFICATION**

**6FF(P) RoHS SERIES**

ISSUED DATE:

2020/08/04

REV. NO.:

A06

DOC. NO.:

HLD-PSI-8004

PAGE:

Page 4 of 9

6.6 平均 I-T 特性曲线图(仅供参考)/ THE AVERAGE I-T CHARACTERISTICS CURVE(FOR REFERENCE ONLY)

**6FF RoHS Average I-T Characteristics Curve(For Reference Only)**  
**6FF RoHS 平均I-T 曲线图(供参考)**

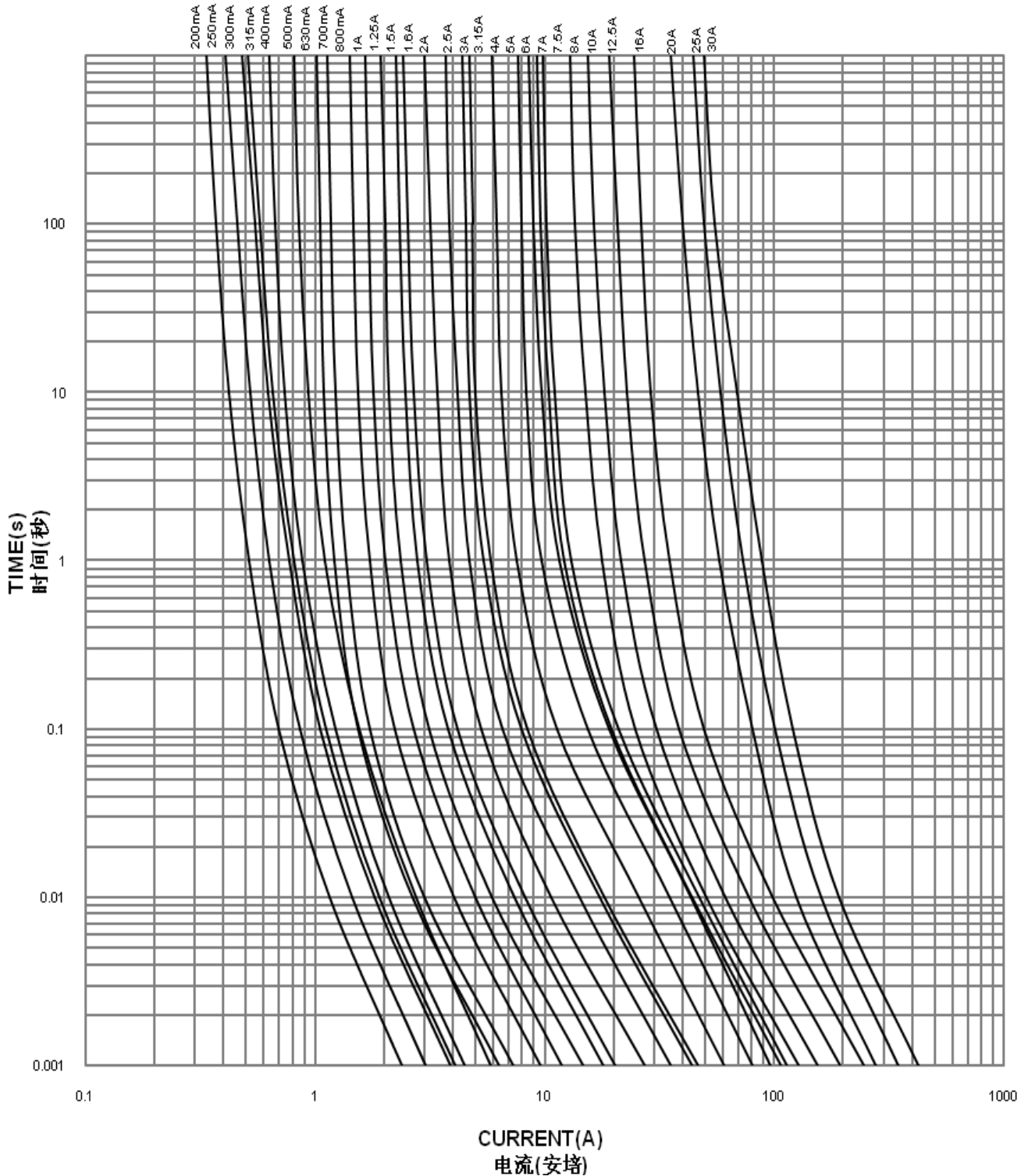



Hollyland (China) Electronics  
Technology Corporation Ltd.  
Hollyland(XiaMen)  
Technology Corporation Ltd.

**PRODUCT SPECIFICATION**

**6FF(P) RoHS SERIES**

ISSUED DATE:

REV. NO.:

DOC. NO.:

PAGE:

2020/08/04

A06

HLD-PSI-8004

Page 5 of 9

6.7 平均 I<sup>2</sup>T-T 特性曲线图(仅供参考)/ THE AVERAGE I<sup>2</sup>T-T CHARACTERISTICS CURVE(FOR REFERENCE ONLY)

**6FF RoHS Average I<sup>2</sup>T-T Characteristics Curve(For Reference Only)**

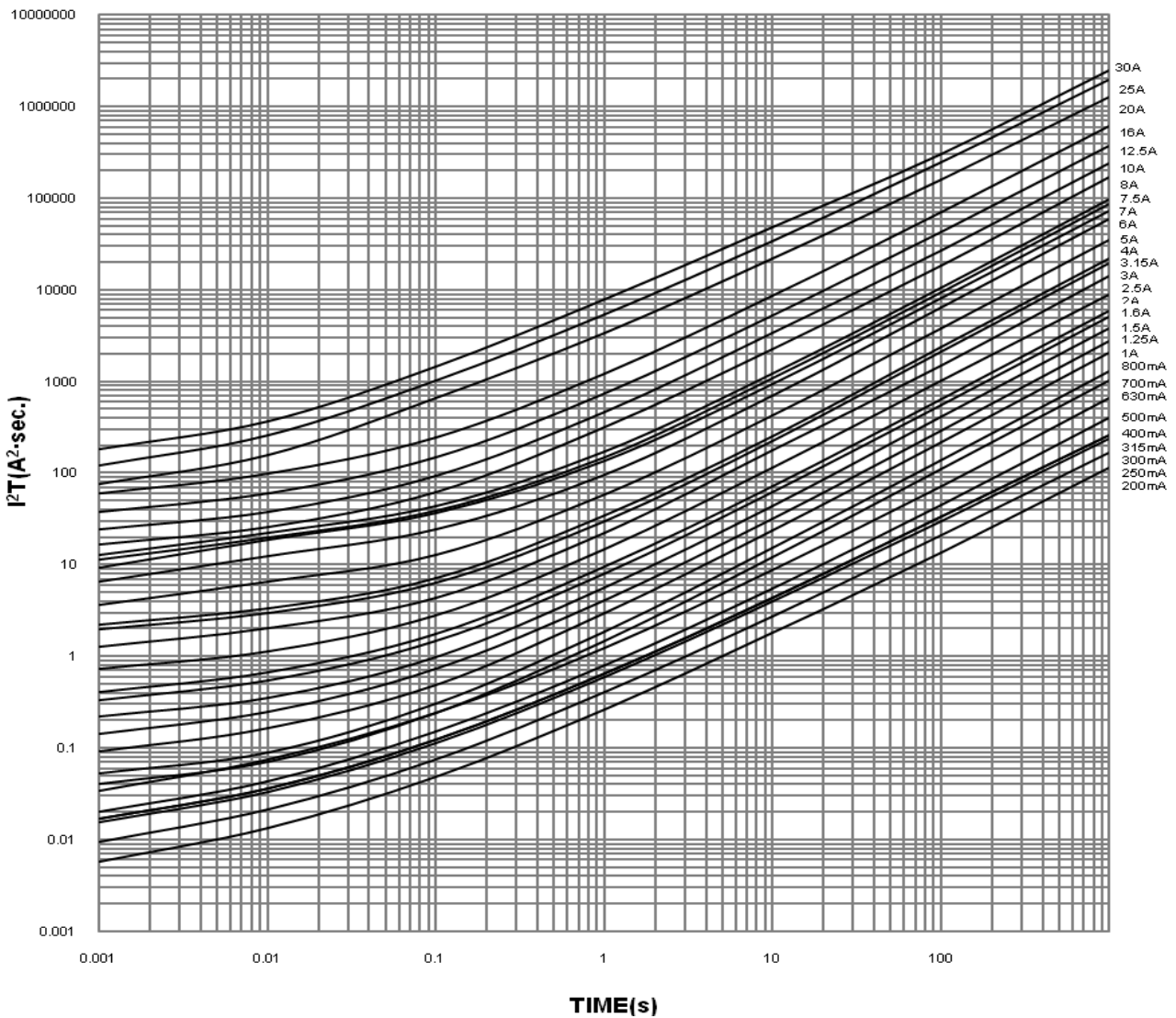

6.8 焊接参数/ SOLDERING PARAMETERS

- 1) 波峰焊---260℃，最大 10 秒。/ Wave soldering---260℃，10 seconds Maximum.  
建议波峰焊接图形/ Suggest wave soldering graphics

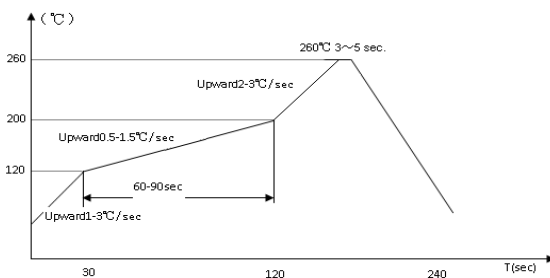

- 2) 手工焊接/ Manual soldering: 350℃, 3sec. Max..
- 3) 耐热焊接/ Resistance to soldering heat: 260℃, 10sec. Max

 Hollyland (China) Electronics Technology Corporation Ltd. Hollyland(XiaMen) Technology Corporation Ltd.	<b>PRODUCT SPECIFICATION</b>	ISSUED DATE: 2020/08/04
	<b>6FF(P) RoHS SERIES</b>	REV. NO.: A06 DOC. NO.: HLD-PSI-8004 PAGE: Page 6 of 9

### 6.8 电阻测试/ COLD RESISTANCE TEST

环境温度为  $25 \pm 2^{\circ}\text{C}$ ，测试电流不大于保险丝额定电流的 10%。

Input 10% of fuse rated current to fuse for cold resistance test at surrounding temperature of  $25 \pm 2^{\circ}\text{C}$ .



### 7 产品标志/ MARKING

7.1 保险丝上的标志应易于看清。

The relevant markings shall be marked on the caps of the fuse and shall be easily visible.

7.2 每个保险丝应标有下列标记。

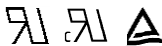
The markings for every fuse shall be prescribed as below according to the types.

- 1) 安全认证标志/ Safety approval logo: 
- 2) 型号名称/ Type: 6FF
- 3) 商标/ Trademark: 
- 4) 额定电压/ Rated Voltage
- 5) 额定电流/ Rated Current

注：1)、2) 和 3) 应标注在保险丝管一端铜帽的侧面。

Note: 1), 2) and 3) should be marked on the one side cap of the fuse.

4) 和 5) 应标注在保险丝管另一端铜帽的侧面。

4) and 5) should be marked on the other side cap of the fuse.

### 8 包装要求/ PACKING DETAILS

8.1 包装方式 A(尾线  $< 40\text{mm}$ ) / EXTERNAL CARTON PACKING A(Pig Tail  $< 40\text{mm}$ )

8.1.1 参考尺寸：长  $\times$  宽  $\times$  高 =  $470 \times 400 \times 230\text{mm}$ 。

Reference Dimension: length  $\times$  width  $\times$  height =  $470 \times 400 \times 230\text{mm}$ .

8.1.2 包装细节：50 个/袋；4 袋/盒；25 盒/箱。

Packing Details: 50EA/ bag; 4 bags/ box; 25 boxes/ Carton.

8.2 包装方式 B(尾线  $\geq 40\text{mm}$ ) / EXTERNAL CARTON PACKING A(Pig Tail  $\geq 40\text{mm}$ )

8.2.1 参考尺寸：长  $\times$  宽  $\times$  高 =  $470 \times 400 \times 230\text{mm}$ 。

Reference Dimension: length  $\times$  width  $\times$  height =  $470 \times 400 \times 230\text{mm}$ .

8.2.2 包装细节：50 个/袋；2 袋/盒；25 盒/箱。

Packing Details: 50EA/ bag; 2 bags/ box; 25 boxes/ Carton.

产品的包装应能达到防潮、抗振的作用，以防在运输或贮存过程中产品受潮或损坏。

Packing shall be so carried out that the products will not absorb moisture or be damaged during transportation or storage.

### 8.3 标签/ LABEL

标签应包括型号、额定电流、额定电压、分断电流、商标、安全标志、批量号码、公司名称、RoHS 标志、绿色“G”和“QA”标志。

The label in the smallest package in which the fuses are put shall contain the Type, Rated current, Rated voltage, Interrupting current, Trademark, Safety approval logo, Lot. No., Company name, “RoHS” mark, green “G” and “QA” mark.

例批量号/Example Lot No.

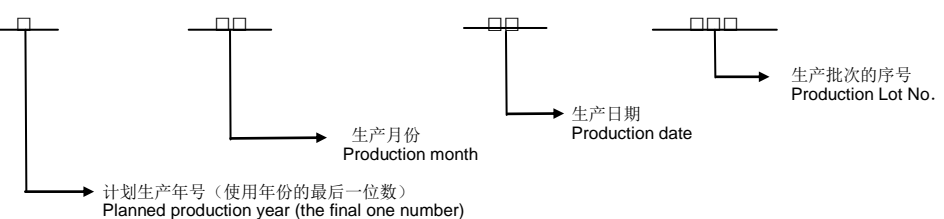

### 9 环境参数/ ENVIRONMENT PARAMETERS

9.1 工作温度/ Operating Temperature:  $-55^{\circ}\text{C} \sim 125^{\circ}\text{C}$ 。

9.2 储存温度/ Storage Temperature:  $-55^{\circ}\text{C} \sim 85^{\circ}\text{C}$ 。

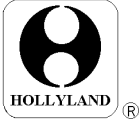
 Hollyland (China) Electronics Technology Corporation Ltd. Hollyland(XiaMen) Technology Corporation Ltd.	<b>PRODUCT SPECIFICATION</b>	ISSUED DATE:	2020/08/04
	<b>6FF(P) RoHS SERIES</b>	REV. NO.:	A06
		DOC. NO.:	HLD-PSI-8004
		PAGE:	Page 7 of 9

## 10 信赖性试验/ RELIABILITY TEST

项目/ Item	试验要求/ Test Requirement	试验条件/ Test Condition
高温试验 High Temperature Test	试验后保险丝管的电阻符合范围; 电气特性符合: 1000%≤6ms、400%≤60ms、100%≥1 小时。 After high temperature test, the resistance value of the fuses shall be in range. Electrical Characteristics: 1000%≤6ms, 400%≤60ms, 100%≥1hour.	测试温度: 105±2℃, 测试时间: 1000 小时。 Test Temperature: 105 ± 2 °C , Test Time: 1000hours.
低温试验 Low Temperature Test	试验后保险丝管的电阻符合范围; 电气特性符合: 1000%≤6ms、400%≤60ms、100%≥1 小时。 After low temperature test, the resistance value of the fuses shall be in range. Electrical Characteristics: 1000%≤6ms, 400%≤60ms, 100%≥1hour.	测试温度: -20±2℃, 测试时间: 1000 小时。 Test Temperature: -20 ± 2 °C , Test Time: 1000hours.
高湿试验 High Humidity Test	试验后保险丝管的电阻符合范围; 电气特性符合: 1000%≤6ms、400%≤60ms、100%≥1 小时。 After high humidity test, the resistance value of the fuses shall be in range. Electrical Characteristics: 1000%≤6ms, 400%≤60ms, 100%≥1hour.	测试温度: 40 ± 2 °C , 测试湿度: 90%~95%, 测试时间: 96 小时。 Test Temperature: 40 ± 2 °C , Test Humidity: 90%~95%, Test Time: 96hours.
热冲击试验 Thermal Shock Test	试验后保险丝管的电阻符合范围; 电气特性符合: 1000%≤6ms、400%≤60ms、100%≥1 小时。 After thermal shock test, the resistance value of the fuses shall be in range. Electrical Characteristics: 1000%≤6ms, 400%≤60ms, 100%≥1hour.	每个循环: -40℃放置 30 分钟后再 85℃放置 30 分钟, 测试 10 循环。 -40 °C / 30mins → 85 °C / 30mins, 10 cycles.
落下、冲击试验 Falling Shock Test	铜帽应固定牢固, 以保证在未损坏熔断体时, 铜帽不能被卸下。铜帽表面镀层应牢固不易脱落, 每个端帽应能经受专用的设备外加的轴向拉力 10N, 保持 1 分钟。陶瓷管必须无缺陷破裂、缺损和污染。试验后保险丝管的电阻符合范围; 电气特性符合: 1000%≤6ms、400%≤60ms、100%≥1 小时。 Cap should be firmly attached so that it is not possible to remove them without damaging the fuse itself. The means of attachment shall be sufficient to withstand an axial pull of 10N applied to each cap for 1 minute. The cap shall be nickel plated firmly. The ceramic tube shall have no defects such as crack and injury. After falling shock test, the resistance value of the fuses shall be in range. Electrical Characteristics: 1000%≤6ms, 400%≤60ms, 100%≥1hour.	一箱 5,000 个保险丝管从一米高自由落下, 跌落 20 次。 5,000EA fuses/ one external carton, Falling Height: 1 meter, Falling Times: 20.
可焊性试验	试验后尾线表面的焊锡覆盖率>95%。 After solderability test, solder coverage of fuse's pig tail will be no more than 95%.	预涂助焊剂 5±1 秒后, 浸入 245±5℃ 的无铅焊锡 5±0.5 秒。 Immerse to flux 5±1sec. then dip in solder bath 245±5 °C , 5±0.5sec..



Hollyland (China) Electronics  
Technology Corporation Ltd.  
Hollyland(XiaMen)  
Technology Corporation Ltd.

**PRODUCT SPECIFICATION**

**6FF(P) RoHS SERIES**

ISSUED DATE:

REV. NO.:

DOC. NO.:

PAGE:

2020/08/04

A06

HLD-PSI-8004

Page 8 of 9

**包装方式 A**  
**PACKING MODE A**

**1 Packing Details 包装细节:**

1.1  $\Phi 3.6 \times 10\text{mm}$  With Pigtail Series:  
200EA/bag, 4 bags/box, 25 boxes/carton, 20,000EA/carton, G.W. 14.5Kgs/ N.W. 11.5Kgs.  
200个袋, 4袋/盒, 25盒/箱, 20,000个箱, 毛重14.5公斤/净重11.5公斤。

1.2  $\Phi 4.5 \times 15\text{mm}$  With Pigtail Series:  
100EA/bag, 4 bags/box, 25 boxes/carton, 10,000EA/carton, G.W. 11.2Kgs/ N.W. 8.2Kgs.  
100个袋, 4袋/盒, 25盒/箱, 10,000个箱, 毛重11.2公斤/净重8.2公斤。

1.3  $\Phi 5.2 \times 20\text{mm}$  With Pigtail Series:  
1.3.1 Glass Tube Fuse With Pigtail  
100EA/bag, 4 bags/box, 25 boxes/carton, 10,000EA/carton, G.W. 15.3Kgs/ N.W. 12.3Kgs.  
100个袋, 4袋/盒, 25盒/箱, 10,000个箱, 毛重15.3公斤/净重12.3公斤。

1.3.2 Ceramic Tube Fuse With Pigtail  
100EA/bag, 4 bags/box, 25 boxes/carton, 10,000EA/carton, G.W. 21.1Kgs/ N.W. 18.1Kgs.  
100个袋, 4袋/盒, 25盒/箱, 10,000个箱, 毛重21.1公斤/净重18.1公斤。

1.4  $\Phi 6.35 \times 32\text{mm}$  With Pigtail Series:  
1.4.1 Glass Tube Fuse With Pigtail  
50EA/bag, 4 bags/box, 25 boxes/carton, 5,000EA/carton, G.W. 17.8Kgs/ N.W. 14.8Kgs.  
50个袋, 4袋/盒, 25盒/箱, 5,000个箱, 毛重17.8公斤/净重14.8公斤。

1.4.2 Ceramic Tube Fuse With Pigtail  
50EA/bag, 4 bags/box, 25 boxes/carton, 5,000EA/carton, G.W. 21Kgs/ N.W. 18Kgs.  
50个袋, 4袋/盒, 25盒/箱, 5,000个箱, 毛重21公斤/净重18公斤。

**2 Material 原材料**  
Box 内盒: Cardboard 纸板。  
Carton 外箱: Double layer corrugated paper 双层瓦楞纸, thickness 厚度>6mm.

**3 Printing and marking 印刷标记**  
Carton with Company name, Tel, Fax, E-mail, Web site, Trademark, Safety logo, BSI ISO9001 and CQC ISO14001:2004 registered firm etc. marked.  
外箱需有公司名称, 电话, 传真, 电子邮箱, 网址, 商标, 安全认证, BSI ISO9001和CQC ISO14001:2004等标记。

**4 RoHS compliant. 符合RoHS指令。**

**Box 盒**  
Dimensions: 230±2, 153±2, 40±2

**Carton 外箱**  
Dimensions: 200, 230±5, 470±5, 400±5

**HOLLYLAND (CHINA) ELECTRONICS TECHNOLOGY CORPORATION LTD.**

**TITLE** Packing For The Fuse With Pigtail  
戴尾瓷保险丝管包装规格

UNLESS OTHERWISE SPECIFIED DIMENSIONS ARE IN MM	DRAWN BY 陶家山	2010.9.9
DWG NO. HLBZ-014A0	CHECKED BY	
MATERIAL	APPROVED BY	
TREATMENT	SCALE	
QUANTITY		

研发部  
2010.9.9  
黄恒明

HLD-RD-31

2	
1	
NO.	REVISED DATE
	REVISED DETAILS

版本: A00





Hollyland (China) Electronics  
Technology Corporation Ltd.  
Hollyland(XiaMen)  
Technology Corporation Ltd.

**PRODUCT SPECIFICATION**

**6FF(P) RoHS SERIES**

ISSUED DATE:

REV. NO.:

DOC. NO.:

PAGE:

2020/08/04

A06

HLD-PSI-8004

Page 9 of 9

**包装方式 B**  
**PACKING MODE B**

**Box 盒**

5 φ: 100EA/ bag, 2 bag/box, 200pcs/box  
100个袋, 2袋/盒, 200个盒  
6 φ: 50EA/ bag, 2 bag/box, 100pcs/box  
50个袋, 2袋/盒, 100个盒

**Carton 外箱**

230±5  
470±5  
400±5  
25 inner boxes in one carton  
25盒/箱

**1 Packing Details 包装细节:**

1.1 φ 5.2 × 20mm With Pigtail Series:  
100EA/bag, 2bags/box, 25 boxes/carton, 5,000EA/carton, G.W. 12.25Kgs/ N.W. 9.05Kgs.  
100个袋, 2袋/盒, 25盒/箱, 5,000个箱, 毛重12.25公斤/净重9.05公斤。

1.2 φ 6.35 × 32mm With Pigtail Series:  
50EA/bag, 2 bags/box, 25 boxes/carton, 2,500EA/carton, G.W. 12.2Kgs/ N.W. 9Kgs.  
50个袋, 2袋/盒, 25盒/箱, 2,500个箱, 毛重12.2公斤/净重9公斤。

**2 Material 原材料**

Box 内盒: Cardboard 纸板  
Carton 外箱: Double layer corrugated paper 双层瓦楞纸, thickness 厚度 > 6mm.

**3 Printing and marking 印刷标识**

Carton with Company name, Tel, Fax, E-mail, Web site, Trademark, Safety logo, BSI ISO9001 and CQC ISO14001:2004 registered firm etc. marked.  
外箱需有公司名称, 电话, 传真, 电子邮箱, 网址, 商标, 安全认证, BSI ISO9001和CQC ISO14001:2004等标识。

**4 RoHS compliant. 符合RoHS指令。**

5 It only applies 5φ: 40mm to 52mm, 6φ: 40mm to 60mm tail series  
仅适用5φ: 40mm至52mm, 6φ: 40mm至60mm尾线规格产品

NO.	REVISED DATE	REVISED DETAILS
1	2017.05.26	更改适用规格

版本: A00

**HOLLYLAND (CHINA) ELECTRONICS TECHNOLOGY CORPORATION LTD.**  
Packing For 6.35 Tube Fuse With Special Pigtail  
5 φ 6.35 管尾线带特殊尾线规格包装

**TITLE**

UNLESS OTHERWISE SPECIFIED DIMENSIONS ARE IN MM

DWG NO. HLBZ-034A1

DRAWN BY 郑善娟 2017.05.26

CHECKED BY

APPROVED BY

SCALE

QUANTITY

TREATMENT

HLD-RD-31

单击下面可查看定价，库存，交付和生命周期等信息

[>>HOLLY\(好利来\)](#)