

| | | | |
|--|------------------------------|--------------|--------------|
|  Hollyland (China) Electronics Technology Corporation Ltd. Hollyland (Xiamen) Technology Corporation Ltd. | PRODUCT SPECIFICATION | ISSUED DATE: | 2019/11/01 |
| | 5HF RoHS SERIES | REV. NO.: | A04 |
| | | DOC. NO.: | HLD-PSI-8022 |
| | | PAGE: | Page 1 of 9 |

| | | | | | |
|-------------------|--------------------------|------------------|--------------------------|-------------------|---------------------------|
| 制定 PREPARED BY | 研发部 2019-11-01 李湖明 | 审核 CHECKED BY | 研发部 2019-11-01 胡兴华 | 批准 APPROVED BY | 副总经理 2019-11-01 赖文辉 |
|-------------------|--------------------------|------------------|--------------------------|-------------------|---------------------------|

1 适用范围/ SCOPE

本规格书适用于公司参照 IEC 60127 标准生产的 5HF RoHS 系列 HOLLY® 商标的小型保险丝管。

This specification defines the technical requirements of miniature fuse type 5HF RoHS series with HOLLY® brand, which are referring to IEC 60127.

产品部件号为: 型号 额定电流 额定电压
Construction of part no.: type rated current rated voltage
例如/ Example: 5HF 020 H

* 额定电压/ Rated Voltage: H - 500V

产品部件号/ PART NUMBER

| 产品部件号 PART NUMBER | 型号规格 MODEL DETAIL | 产品部件号 PART NUMBER | 型号规格 MODEL DETAIL |
|----------------------|----------------------|----------------------|----------------------|
| 5HF-0250H | 5HF F250mA 500V | 5HF-032H | 5HF F3.15A 500V |
| 5HF-0315H | 5HF F315mA 500V | 5HF-040H | 5HF F4A 500V |
| 5HF-0400H | 5HF F400mA 500V | 5HF-050H | 5HF F5A 500V |
| 5HF-0500H | 5HF F500mA 500V | 5HF-063H | 5HF F6.3A 500V |
| 5HF-0630H | 5HF F630mA 500V | 5HF-080H | 5HF F8A 500V |
| 5HF-0800H | 5HF F800mA 500V | 5HF-100H | 5HF F10A 500V |
| 5HF-010H | 5HF F1A 500V | 5HF-120H | 5HF F12A 500V |
| 5HF-013H | 5HF F1.25A 500V | 5HF-125H | 5HF F12.5A 500V |
| 5HF-016H | 5HF F1.6A 500V | 5HF-150H | 5HF F15A 500V |
| 5HF-020H | 5HF F2A 500V | 5HF-160H | 5HF F16A 500V |
| 5HF-025H | 5HF F2.5A 500V | 5HF-200H | 5HF F20A 500V |

型号规格: 型号 特性符号 额定电流 额定电压
MODEL DETAIL: Type Characteristic Symbol Rated Current Rated Voltage
例如/ Example: 5HF E 2A 500V

*特性符号/ Characteristic Symbol: F –速断型/ Quick-Acting.

2 相关标准/ APPLICABLE STANDARDS

2.1 5HF RoHS 系列产品适用的相关标准是 IEC 60127-1 和 IEC 60127-7。

Applicable standards for 5HF RoHS series are IEC 60127-1 and IEC 60127-7.

2.2 认证情况/ APPROVED DETAILS

| 额定电压 RATED VOLTAGE | 认证范围 APPROVED RANGE | 认证号码 CERT. NO. | |
|-----------------------|------------------------|----------------|-----------|
| | | cURus | TUV |
| 300Vac/dc | 0.25A~20A | E156471 | R50319060 |
| 420Vac/dc | | | |
| 450Vdc | | | |
| 500Vac | | | |
| 600Vac | | | |

3 公司地址/ ADDRESS

中国福建省厦门市翔安区舩山东二路 829 号
829 Fangshan East 2nd Road, Xiang'an, Xiamen, China.

| | | | |
|--|------------------------------|--------------|--------------|
|  Hollyland (China) Electronics Technology Corporation Ltd. Hollyland (Xiamen) Technology Corporation Ltd. | PRODUCT SPECIFICATION | ISSUED DATE: | 2019/11/01 |
| | 5HF RoHS SERIES | REV. NO.: | A04 |
| | | DOC. NO.: | HLD-PSI-8022 |
| | | PAGE: | Page 2 of 9 |

4 构造图/ CONSTRUCTION FIG. & DIMENSION

4.1 DIMENSION (Unit: mm)

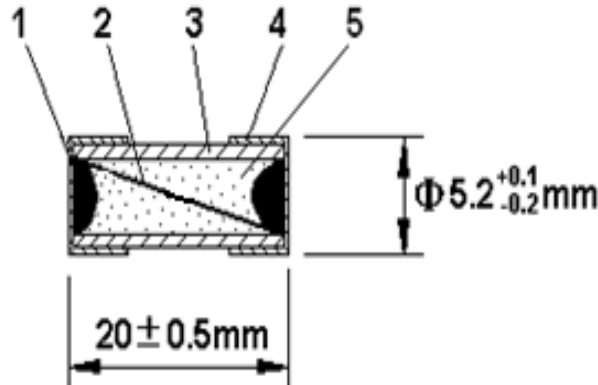

| 编号 No. | 品名 PART | 材料名 MATERIAL MODEL | 备注 NOTE |
|-----------|--------------|-----------------------|--------------------|
| 1 | 焊锡/ Solder | 无铅焊锡/ Pb Free | / |
| 2 | 可熔体/ Element | 金属丝/ Metal Wire | 额定电流 $I_n < 8A$ |
| | | 金属片/ Metal Strip | 额定电流 $I_n \geq 8A$ |
| 3 | 管体/ Tube | 陶瓷管/ Ceramic Tube | 灌砂/ Filled Sand |
| 4 | 铜帽/ Cap | 黄铜/ Brass | 镀镍/ Nickel Plated |
| 5 | 填充物/ Filler | 石英砂/ Quartz Sand | / |

4.2 陶瓷管/ CERAMIC TUBE

陶瓷管无破裂、缺损或污染等现象。

The ceramic tube shall have no defects such as crack, injury and contamination.

4.3 铜帽/ CAP

铜帽应焊接牢固，以保证在未损坏熔断体时，铜帽不能被卸脱。样品在 15℃-35℃ 水中浸 24 小时取出后，在每个端帽上均匀施加拉力至 10N，保持 1 分钟，铜帽不应脱落。

Cap should be firmly attached so that it is not possible to remove them without damaging the fuse itself. The samples are immersed in water for 24 hours at a temperature between 15℃ and 35℃. After remove from the water, an axial pull steadily increasing to 10N is applied to each cap for 1 minute.

4.4 焊点/ SOLDERING JOINT

焊接铜帽端时,管内和铜帽外表面不能有残留的助焊剂、焊锡等异物。

Soldering joint in end cap shall not be melted during normal operation and shall not have solder chips on tube, element in view and outer surface of caps.

5 机械特性/ MECHANICAL PERFORMANCES

5.1 拉力试验/ Tensile Strength

固定保险丝的一端铜帽，然后在另一端铜帽上，沿水平轴方向施加 10N 的拉力，两端铜帽不应松动且管体不应破碎。

When one end cap of the specimen is fixed and then the tensile force 10N is applied to the other end cap in a direction to separate the end caps, no looseness of end caps or damage of fuse-tube shall occur.

5.2 扭力试验/ Rotational Strength

固定保险丝的一端铜帽，然后在另一端铜帽上顺时针和逆时针方向上顺序施加 30N·mm 力矩，两端铜帽不

| | | | |
|--|------------------------------|--------------|--------------|
|  Hollyland (China) Electronics Technology Corporation Ltd. Hollyland (Xiamen) Technology Corporation Ltd. | PRODUCT SPECIFICATION | ISSUED DATE: | 2019/11/01 |
| | 5HF RoHS SERIES | REV. NO.: | A04 |
| | | DOC. NO.: | HLD-PSI-8022 |
| | | PAGE: | Page 3 of 9 |

应松动，管体也不应破碎。

When one end cap of the specimen is fixed and then the torque 30N·mm is applied to the other end cap clockwise and counterclockwise, no looseness of end caps at both ends or damage of fuse-tube shall occur.

5.3 管体强度试验/ Strength of Fuse-tube

两端铜帽固定好后，在玻璃管的中心位置施加 25N 的压力，管体不应破碎。

When middle parts of end caps at both ends of the specimen are supported and then the force 25N is applied to the middle part of the fuse-tube, no damage of the fuse-tube shall occur.

6 电气特性/ ELECTRICAL PERFORMANCES

6.1 预飞弧时间电流-特性/ PRE-ARCING TIME-CURRENT CHARACTERISTICS

| 额定电流 Rated Current | 2.1I _n | 2.75I _n | | 4I _n | | 10I _n |
|-----------------------|-------------------|--------------------|--------|-----------------|-------|------------------|
| | Max. | Min. | Max. | Min. | Max. | Max. |
| 250mA-4A | 30min. | 10ms | 2sec. | 3ms | 300ms | 20ms |
| 5A-6.3A | 30min. | 10ms | 3sec. | 3ms | 300ms | 20ms |
| 8A-10A | 30min. | 40ms | 20sec. | 10ms | 1sec. | 30ms |
| >10A | 30min. | 40ms | 20sec. | 10ms | 1sec. | 40ms |

6.2 分断能力/ BREAKING CAPACITY

这些型号的保险丝的分断能力应能达到下表规定的相应的各种安全认证的分断能力要求。保险丝分断电路后，保险丝管不应破裂、铜帽飞脱、且铜帽两端的绝缘电阻不小于 0.1MΩ。

The breaking capacity should reach the breaking rated current given in the following table. And after this test, there should be no damage of the fuse-tube or shattering of the caps. After this test, the insulation resistance between the end caps shall be not less than 0.1MΩ.

| 额定电压 RATED VOLTAGE | 分断电流/ BREAKING CURRENT | |
|-----------------------|--|-----------------------------------|
| | UR/ CUR /TUV | |
| 300Vac/dc | 1500A 300Vdc Time Constant≤1ms 1500A 300Vac | |
| 420Vdc/ 450Vdc | 1500A(250mA~3.15A) Time Constant≤1ms | 400A(4A~20A) Time Constant≤1ms |
| 420Vac/ 500Vac | 1000A(200mA~3.15A) | 200A(4A~20A) |
| 600Vac | 100A | |

6.3 耐久性试验/ ENDURANCE TEST

耐久性试验过程。/ The process of endurance test is as follows.

A 对熔断体通过 **1.0** 倍的额定电流 1 小时，然后切断电流 15 分钟，重复此循环 100 次。/ A current **1.0I_n** is passed through the fuse-link for a period of 1hour. The current is then switched off for a period of 15 minutes. The cycle is repeated 100 times.

B 然后对熔断体通以 1.5 倍额定电流 1 小时(I_n≤6.3A)或 0.5 小时(**10A ≥I_n>6.3A**)，**对熔断体通以 1.25 倍额定电流 1 小时 (I_n>10A)**。/ A current 1.5I_n is then passed through the fuse-link for 1hour(I_n≤6.3A) or 0.5hour(**10A ≥I_n>6.3A**), **A current 1.25I_n is then passed through the fuse-link for 1hour(I_n>10A)**.

C 测量熔断体两端的电压降。试验后，熔断体两端的电压降的增大量不大于试验前测得值的 10%。/ Finally, the voltage drop across the fuse-link is measured. The voltage drop across the fuse-link after the test shall not have increased by more than 10% of the Value measured before the test.



Hollyland (China) Electronics
Technology Corporation Ltd.
Hollyland (Xiamen) Technology
Corporation Ltd.

PRODUCT SPECIFICATION

5HF RoHS SERIES

ISSUED DATE:

2019/11/01

REV. NO.:

A04

DOC. NO.:

HLD-PSI-8022

PAGE:

Page 4 of 9

D 试验后,标记仍应清晰可辨,而且诸如端帽上的焊点不应出现任何明显的劣变。/ After the test, the marking shall still be legible and soldered joints on end caps, for example, shall not show and appreciable deterioration.

6.4 平均 I-T 特性曲线图(仅供参考)/THE AVERAGE I-T CHARACTERISTICS CURVE(FOR REFERENCE ONLY)

5HF RoHS Average I-T Characteristics Curve(For Reference Only)

5HF RoHS 平均电流-时间曲线图(供参考)

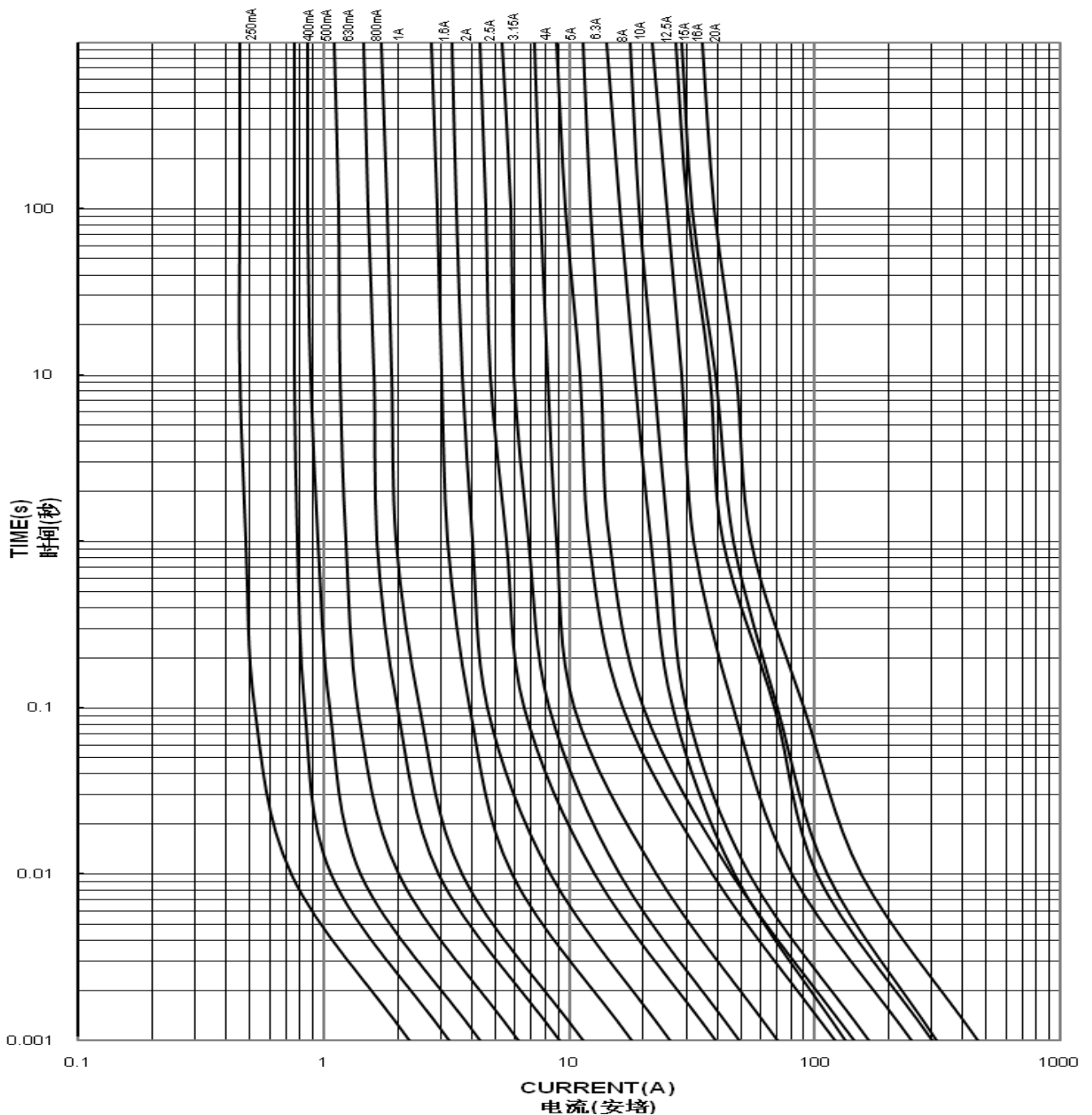

| | | | |
|---|------------------------------|--------------|--------------|
|  <p>Hollyland (China) Electronics Technology Corporation Ltd. Hollyland (Xiamen) Technology Corporation Ltd.</p> | PRODUCT SPECIFICATION | ISSUED DATE: | 2019/11/01 |
| | 5HF RoHS SERIES | REV. NO.: | A04 |
| | | DOC. NO.: | HLD-PSI-8022 |
| | | PAGE: | Page 5 of 9 |

6.5 平均 I²T-T 特性曲线图(仅供参考)/ THE AVERAGE I²T-T CHARACTERISTICS CURVE(FOR REFERENCE ONLY)

5HF RoHS Average I²T-T Characteristics Curve(For Reference Only)

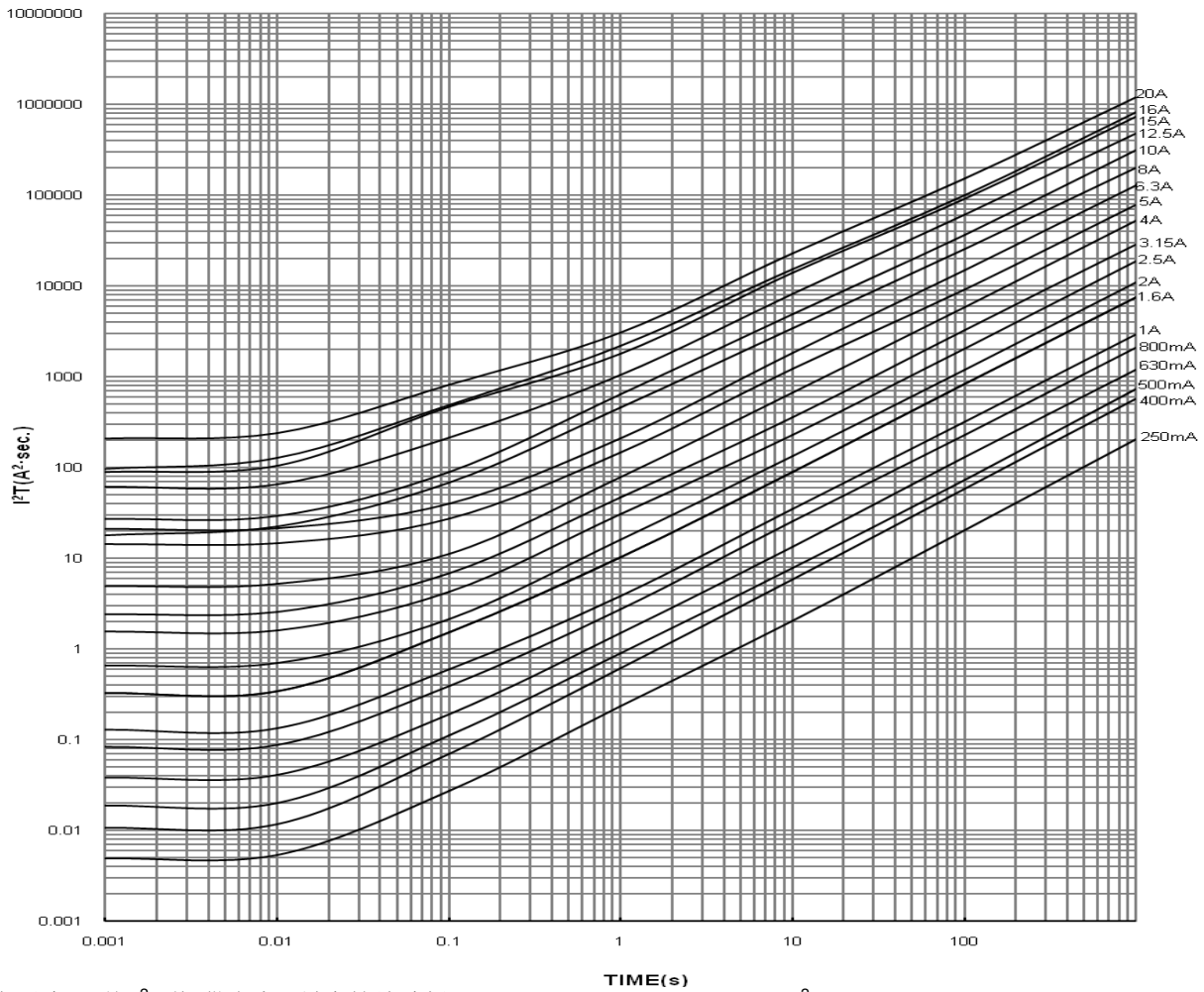

6.6 电压降、平均 I²T 值(供参考)、最大持续功耗/ VOLTAGE DROP, AVERAGE I²T VALUE(FOR REFERENCE ONLY) And MAXIMUM SUSTAINED DISSIPATION

| 额定电流 Rated Current | 1.0I _n 最大电压降 1.0I _n VOLTAGE DROP Max.(mV) | 平均 I ² T 值/ Average I ² T Value(A ² ·sec.) | 1.5I _n 最大持续功耗 1.5I _n Maximum Sustained Dissipation (W) | 额定电流 Rated Current | 1.0I _n 最大电压降 1.0I _n VOLTAGE DROP Max.(mV) | 平均 I ² T 值/ Average I ² T Value(A ² ·sec.) | 1.5I _n 最大持续功耗 1.5I _n Maximum Sustained Dissipation (W) | |
|-----------------------|--|--|---|-----------------------|--|--|---|---|
| 250mA | 2800 | 0.0054 | 2.5 | 5A | 250 | 14.55 | 4 | |
| 400mA | 2000 | 0.0117 | | 6.3A | 200 | 21.38 | | |
| 500mA | 1800 | 0.0202 | | 8A | 200 | 17.94 | | |
| 630mA | 1500 | 0.0409 | | 10A | 200 | 29.51 | | |
| 800mA | 1200 | 0.0874 | | | | | | |
| 1A | 1000 | 0.1330 | | | | | | |
| 1.6A | 600 | 0.3415 | 4 | 额定电流 Rated Current | 1.0I _n 最大电压降 1.0I _n VOLTAGE DROP Max.(mV) | 平均 I ² T 值/ Average I ² T Value(A ² ·sec.) | 1.25I _n 最大持续功耗 1.25I _n Maximum Sustained Dissipation (W) | |
| 2A | 500 | 0.6986 | | 12.5A | 180 | 61.96 | 4 | |
| 2.5A | 400 | 1.613 | | 15A | 180 | 90.41 | 6 | |
| 3.15A | 350 | 2.592 | | 16A | 180 | 98.79 | | |
| 4A | 300 | 5.200 | | | 20A | 180 | 211.3 | 8 |

| | | | |
|--|------------------------------|--------------|--------------|
|  Hollyland (China) Electronics Technology Corporation Ltd. Hollyland (Xiamen) Technology Corporation Ltd. | PRODUCT SPECIFICATION | ISSUED DATE: | 2019/11/01 |
| | 5HF RoHS SERIES | REV. NO.: | A04 |
| | | DOC. NO.: | HLD-PSI-8022 |
| | | PAGE: | Page 6 of 9 |

6.7 电阻测试/ COLD RESISTANCE TEST

环境温度为 $25 \pm 2^\circ\text{C}$ ，测试电流不大于保险丝额定电流的 10%。

Input 10% of fuse rated current to fuse for cold resistance test at surrounding temperature of $25 \pm 2^\circ\text{C}$.



7 产品标志/ MARKING

7.1 保险丝上的标志应易于看清。

The relevant markings shall be marked on the caps of the fuse and shall be easily visible.

7.2 每个保险丝应标有下列标记。

The markings for every fuse shall be prescribed as below according to the types.

- 1) 安全认证标志/ Safety Approval Logo:  
- 2) 型号名称/ Type: 5HF
- 3) 商标/ Trademark: 
- 4) 特性符号/ Characteristic Symbol: F
- 5) 额定电流/ Rated Current
- 6) 额定电压/ Rated Voltage

注：1)、2) 和 3)应标注在保险丝管一端铜帽的侧面。

Note: 1), 2) and 3) should be marked on the one side cap of the fuse.

4)、5)和 6)应标注在保险丝管另一端铜帽的侧面。

4), 5) and 6) should be marked on the other side cap of the fuse.

8 包装要求/ PACKING DETAILS

8.1 外箱包装方式/ EXTERNAL CARTON PACKING

8.1.1 包装方式 A/ PACKING MODE A

8.1.1.1 参考尺寸：长×宽×高=320×240×165mm。

Reference Dimension: Length×Width×Height=320×240×165mm.

8.1.1.2 包装细节：200EA/小塑料袋；25 小塑料袋/大塑料袋；2 大塑料袋/每箱。

Packing Details: 200EA/ little plastic-bag; 25 little plastic-bags/ big plastic-bag; 2 big plastic-bags/ External Carton.

8.1.2 包装方式 B/ PACKING MODE B

8.1.2.1 参考尺寸：长×宽×高=375×245×165mm。

Reference Dimension: Length×Width×Height=375×245×165mm.

8.1.2.2 包装细节：200EA/小塑料袋；5 小塑料袋/盒；10 盒/每箱。

Packaging Details: 200EA/ little plastic-bag; 5 little plastic-bags/ box; 10 boxes/ External Carton.

产品的包装应能达到防潮、抗振的作用，以防在运输或贮存过程中产品受潮或损坏。

Packing shall be so carried out that the products will not absorb moisture or be damaged during transportation or storage.

8.2 标签/ LABEL

标签应包括型号、额定电流、额定电压、额定分断电流、商标、安全标志、批量号码、公司名称、RoHS 标志、绿色“G”、绿色“e”（仅无铅产品）和“QA”标志。

The label in the smallest package in which the fuses are put shall contain the Type, Rated current, Rated voltage, Breaking current, Trademark, Safety approval logo, Lot. No., Company name, “RoHS” mark, green “G”, green “e” (only Pb free products) and “QA” mark.

例批量号：

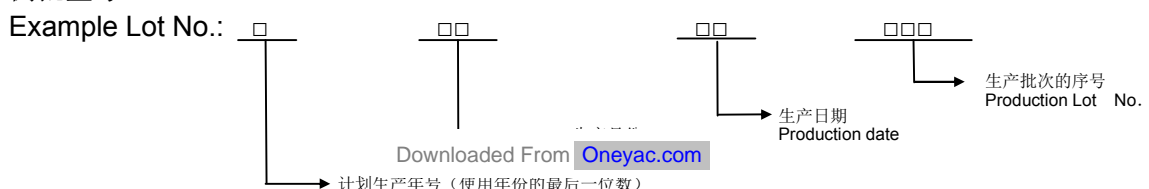

| | | | |
|---|------------------------------|--------------|--------------|
|  <p>Hollyland (China) Electronics Technology Corporation Ltd. Hollyland (Xiamen) Technology Corporation Ltd.</p> | PRODUCT SPECIFICATION | ISSUED DATE: | 2019/11/01 |
| | 5HF RoHS SERIES | REV. NO.: | A04 |
| | | DOC. NO.: | HLD-PSI-8022 |
| | | PAGE: | Page 7 of 9 |

9 环境参数/ ENVIRONMENT PARAMETERS

9.1 工作温度/ Operating Temperature: -55℃~125℃.

9.2 储存温度/ Storage Temperature: -55℃~85℃.

10 信赖性试验/ RELIABILITY TEST

| 项目/ Item | 试验要求/ Test Requirement | 试验条件/ Test Condition |
|-------------------------------|---|--|
| 高温试验 High Temperature Test | 试验后保险丝管的电阻符合范围；电气特性符合：210% ≤30 分、150% ≥1 小时($I_n \leq 6.3A$)或 0.5 小时($10A \geq I_n > 6.3A$)或 125% ≥1 小时($I_n > 10A$) 。 After high temperature test, the resistance value of the fuses shall be in range. Electrical Characteristics:210% ≤30minutes, 150% ≥1hour($I_n \leq 6.3A$) or 0.5hour($I_n > 6.3A$) or125% ≥1hour($I_n > 10A$) . | 测试温度: 105 ± 2℃, 测试时间: 1000 小时。 Test Temperature: 105 ± 2℃, Test Time: 1000hours. |
| 低温试验 Low Temperature Test | 试验后保险丝管的电阻符合范围；电气特性符合：210% ≤30 分、150% ≥1 小时($I_n \leq 6.3A$)或 0.5 小时($10A \geq I_n > 6.3A$)或 125% ≥1 小时($I_n > 10A$) 。 After high temperature test, the resistance value of the fuses shall be in range. Electrical Characteristics:210% ≤30minutes, 150% ≥1hour($I_n \leq 6.3A$) or 0.5hour($I_n > 6.3A$) or125% ≥1hour($I_n > 10A$) . | 测试温度: -20 ± 2℃, 测试时间: 1000 小时。 Test Temperature: -20 ± 2℃, Test Time: 1000hours. |
| 高湿试验 High Humidity Test | 试验后保险丝管的电阻符合范围；电气特性符合：210% ≤30 分、150% ≥1 小时($I_n \leq 6.3A$)或 0.5 小时($10A \geq I_n > 6.3A$)或 125% ≥1 小时($I_n > 10A$) 。 After high temperature test, the resistance value of the fuses shall be in range. Electrical Characteristics:210% ≤30minutes, 150% ≥1hour($I_n \leq 6.3A$) or 0.5hour($I_n > 6.3A$) or125% ≥1hour($I_n > 10A$) . | 测试温度: 40 ± 2℃, 测试湿度: 90%~95%, 测试时间: 96 小时。 Test Temperature: 40 ± 2℃, Test Humidity: 90%~95%, Test Time: 96hours. |
| 热冲击试验 Thermal Shock Test | 试验后保险丝管的电阻符合范围；电气特性符合：210% ≤30 分、150% ≥1 小时($I_n \leq 6.3A$)或 0.5 小时($10A \geq I_n > 6.3A$)或 125% ≥1 小时($I_n > 10A$) 。 After high temperature test, the resistance value of the fuses shall be in range. Electrical Characteristics:210% ≤30minutes, 150% ≥1hour($I_n \leq 6.3A$) or 0.5hour($I_n > 6.3A$) or125% ≥1hour($I_n > 10A$) . | 每个循环: -40℃放置 30 分钟后 85℃放置 30 分钟, 测试 10 循环。 -40℃/ 30minutes → 85℃/ 30minutes, 10 cycles. |
| 落下、冲击试验 Falling Shock Test | 铜帽应固定牢固,以保证在未损坏熔断体时,铜帽不能被卸下。铜帽表面镀层应牢固不易脱落,每个端帽应能经受专用的设备外加的轴向拉力 10N,保持 1 分钟。陶瓷管必须无缺陷破裂和缺损。试验后保险丝管的电阻符合范围；电气特性符合：210% ≤30 分、150% ≥1 小时($I_n \leq 6.3A$)或 0.5 小时($10A \geq I_n > 6.3A$)或 125% ≥1 小时($I_n > 10A$) 。 Cap should be firmly attached so that it is not possible to remove them without damaging the fuse itself. The means of attachment shall be sufficient to withstand an axial pull of 10N applied to each cap for 1 minute. The cap shall be nickel plated firmly. The ceramic tube shall have no defects such as crack and injury. After high temperature test, the resistance value of the fuses shall be in range. Electrical Characteristics:210% ≤30minutes, 150% ≥1hour($I_n \leq 6.3A$) or 0.5hour($I_n > 6.3A$) or125% ≥1hour($I_n > 10A$) . | 一箱 10,000 个保险丝管从一米高自由落下,跌落 20 次。 10,000EA fuses/ one external carton, Falling height: 1 meter, Falling times: 20. |

| | | |
|---|------------------------------|---|
|  HOLLYLAND [®] Hollyland (China) Electronics Technology Corporation Ltd. Hollyland (Xiamen) Technology Corporation Ltd. | PRODUCT SPECIFICATION | ISSUED DATE: 2019/11/01 REV. NO.: A04 DOC. NO.: HLD-PSI-8022 PAGE: Page 8 of 9 |
| | 5HF RoHS SERIES | |

包装方式 A Package A

大塑料袋 Big-Plastic-Bag



200 个/小塑料袋; 25 小塑料袋/大塑料袋
 200EA/ little plastic-bag; 25 little plastic-bags/ big plastic-bag
 5,000 个/大塑料袋
 5,000EA/ big plastic-bag

外箱 External Carton

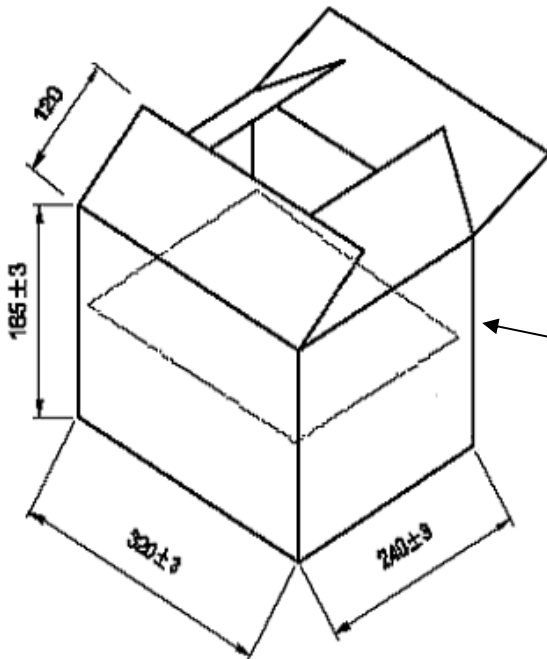

2 个大塑料袋/箱
 2EA big plastic-bags in one carton

1 重量 Weight

一个外箱(装满 10,000 个保险丝管)毛重 13 公斤/净重 12.5 公斤。

One external carton(filled with 10,000EA fuses): G.W. 13Kgs/ N.W. 12.5Kgs.

2 原材料 Material

内盒 Inner box: 纸板 Cardboard.

外箱 External carton: 双层瓦楞纸 Double layer corrugated paper, 厚度 Thickness>6mm.

3 印刷标志 Printing and Marking

外箱需有公司名称、电话、传真、电子邮箱、网址、商标、安全标志、RoHS、BSI ISO9001 和 CQC ISO14001:2004 等标志。

External carton With Company name, Tel, Fax, E-mail, Web site, Trade make, Safety approval logo, RoHS, BSI ISO9001 and CQC ISO14001:2004 registered firm etc..

| | | |
|---|------------------------------|--|
|  <p>Hollyland (China) Electronics Technology Corporation Ltd. Hollyland (Xiamen) Technology Corporation Ltd.</p> | PRODUCT SPECIFICATION | ISSUED DATE: 2019/11/01 |
| | 5HF RoHS SERIES | REV. NO.: A04 DOC. NO.: HLD-PSI-8022 PAGE: Page 9 of 9 |

包装方式 B Package B

内盒 Inner Box

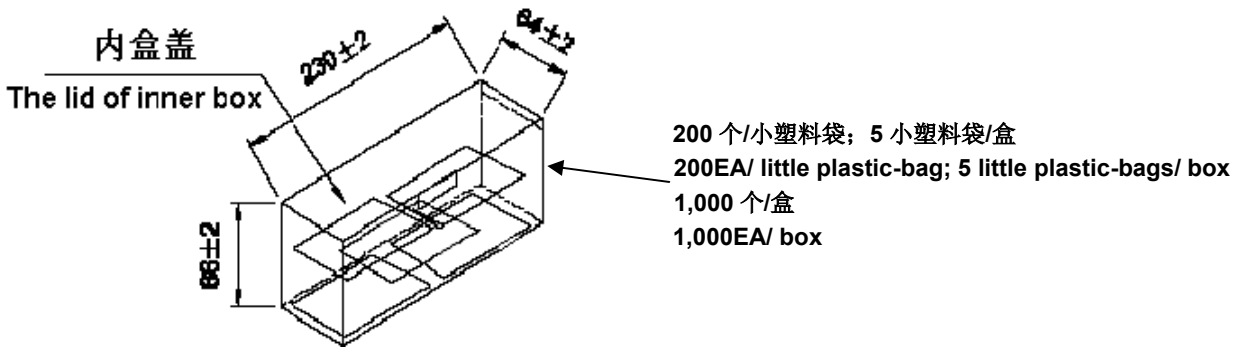

外箱 External Carton

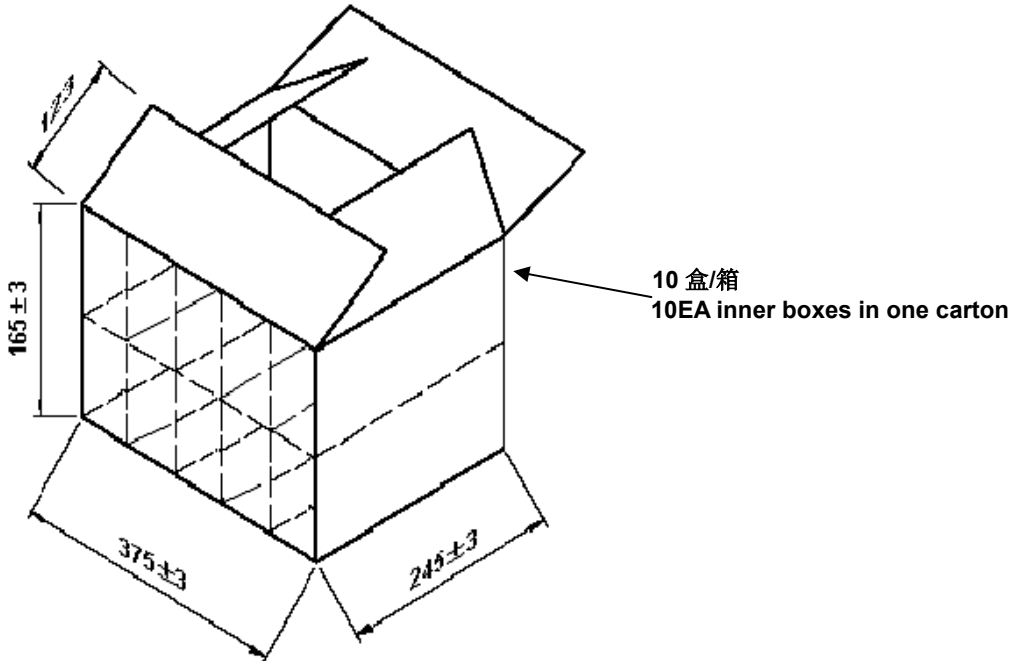

1 重量 Weight

一个外箱(装满 10,000 个保险丝管)毛重 13.5 公斤/净重 12.5 公斤。

One external carton(filled with 10,000EA fuses): G.W. 13.5Kgs/ N.W. 12.5Kgs.

2 原材料 Material

内盒 Inner box: 纸板 Cardboard.

外箱 External carton: 双层瓦楞纸 Double layer corrugated paper, 厚度 Thickness>6mm.

3 印刷标志 Printing and Marking

外箱需有公司名称、电话、传真、电子邮箱、网址、商标、安全标志、RoHS、BSI ISO9001 和 CQC ISO14001:2004 等标志。

External carton With Company name, Tel, Fax, E-mail, Web site, Trade make, Safety approval logo, RoHS, BSI ISO9001 and CQC ISO14001:2004 registered firm etc..

单击下面可查看定价，库存，交付和生命周期等信息

[>>HOLLY\(好利来\)](#)