

High Temperature Quad Operational Amplifier HT1104

The High Temperature Quad Operational Amplifier, HT1104, is a versatile performer over an extremely wide temperature range. It is fabricated with Honeywell's dielectrically isolated high-temperature linear (HTMOS™) process, and is designed specifically for use in systems operating in severe high temperature environments.



These amplifiers perform over the full -55°C to 225°C temperature range. All parts are burned in at 250°C. The HT1104 will operate with both single and split supplies. High temperature circuit applications such as transducer interfacing, amplification, active filtering, and signal buffering are all possible with the HT1104.

APPLICATIONS:

- Down-Hole Oil Well
- Turbine Engine Control
- Avionics
- Industrial Process Control
- Electric Power Conversion
- Heavy Duty Internal Combustion Engine

PINOUT DIAGRAM

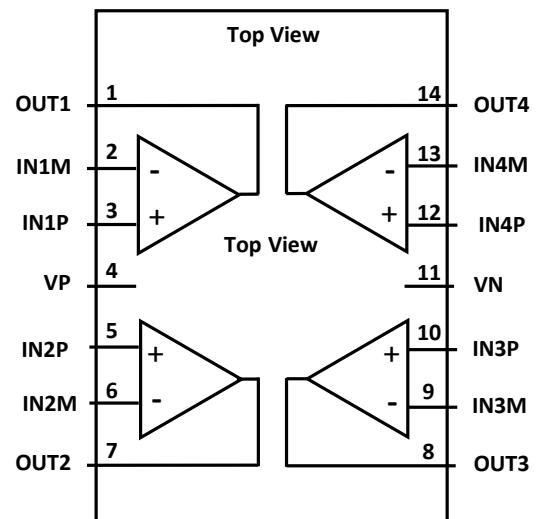

FEATURES

- ▶ Specified Over -55°C to +225°C
- ▶ Single or Split Supply Operation
- ▶ Low Input Bias and Offset Parameters
- ▶ ESD Protection Circuitry
- ▶ Latch-up Free Design with Dielectric Isolation
- ▶ Hermetic 14-Lead Ceramic DIP package, or die

ABSOLUTE MAXIMUM RATINGS (1)

Symbol	Parameter	Rating		Units
		Min	Max	
VN to VP	Total Supply Voltage		13	V
VPIN	Voltage on Any Pin (excluding power pins)	VN - 0.5	VP + 0.5	V
IOUT	DC or Average Output Current (each output)	-50	+50	mA
IOS	Output Short Circuit Current (1 second)		110	mA
VHBM	ESD Input Protection Voltage (Human Body Model)		2000	V
ΘJC	Thermal Resistance (Jct-to-Case)		10	°C/W
TSTORE	Storage Temperature	-65	300	°C
TSOLDER	Lead Temperature (soldering, 10 seconds)		355	°C
TJ	Junction Temperature		315	°C

(1) Stresses in excess of those listed above may result in permanent damage. These are stress ratings only, and operation at these levels is not implied. Frequent or extended exposure to absolute maximum conditions may affect device reliability.

RECOMMENDED OPERATING CONDITIONS

Symbol	Parameter	Min	Max	Units
VP	Positive Supply Voltage (Single supply)	5	10	V
VN	Negative Supply Voltage (Single supply)	0		V
VP	Positive Supply Voltage (Split supply)		+5	V
VN	Negative Supply Voltage (Split supply)	-5		V
IOUT	Continuous Output Current	-10	+10	mA
VPIN	Voltage on Any Pin (excluding power pins)	VN - 0.3	VP + 0.3	V
TC	Case Temperature	-55	225	°C

ELECTRICAL SPECIFICATIONS

Unless otherwise specified, specifications apply over the Recommended Operating Conditions.

VP = +5V, VN = -5V.

Symbol	Parameter	Conditions	Limits		Unit
			Min	Max	
Ip	Supply Current			12.5	mA
VO	Output Voltage Swing	R = 10kΩ, C = 20pF	-4.8	+4.6	V
ISOH	Output Short Circuit Current High	Open Loop, VP > VN, Vo = 0V, Absolute value		110	mA
ISOL	Output Short Circuit Current Low	Open Loop, VN > VP, Vo = 0V, Absolute value		110	mA
ISOURCE	Output Drive Current - source	Open Loop, VP > VN, Vo = 0V, absolute value	10		mA
ISINK	Output Drive Current - sink	Open Loop, VN > VP, Vo = 0V, absolute value	10		mA
IIO	Input Offset Current	-55°C to 25°C	-10	10	nA
		+225°C	-50	50	nA
IIB	Input Bias Current	-55°C to 25°C	-10	10	nA
		+225°C	-50	50	nA
VIO	Input Offset Voltage		-7	7	mV

Symbol	Parameter	Conditions	Limits		Unit
			Min	Max	
V _{CM}	Input Common Mode Voltage Range	25°C to +225°C, -55°C	V _N +0.2	V _P -2.2	V
			V _N +0.2	V _P -2.4	V
A _{VOL}	DC Open Loop Gain		100		dB
CMRR	Common Mode Rejection Ratio		80		dB
PSRR	Power Supply Rejection Ratio		66		dB

TYPICAL ELECTRICAL SPECIFICATIONS

The following specifications are not tested on each device and are for reference only.

Symbol	Parameter	Conditions	Typical	Units
V _{IO}	Input Offset Voltage	Drift with Temperature	10	μV/°C
N	Noise	f _o = 10 Hz	200	nv/√Hz
		f _o = 1 kHz	30	nv/√Hz
		f = 0.1 to 10 Hz	8	μV, p-p
SR	Slew Rate	R = 10kΩ, C = 20pF, 25°C	1.4	V/μsec
UGB	Unity Gain Bandwidth	R = 10kΩ, C = 20pF, 25°C	1.4	MHz
∅M	Phase Margin	C = 20pF	60	degrees
AM	Gain Margin	C = 20pF	8	dB

SIMPLIFIED SCHEMATIC (each amplifier)

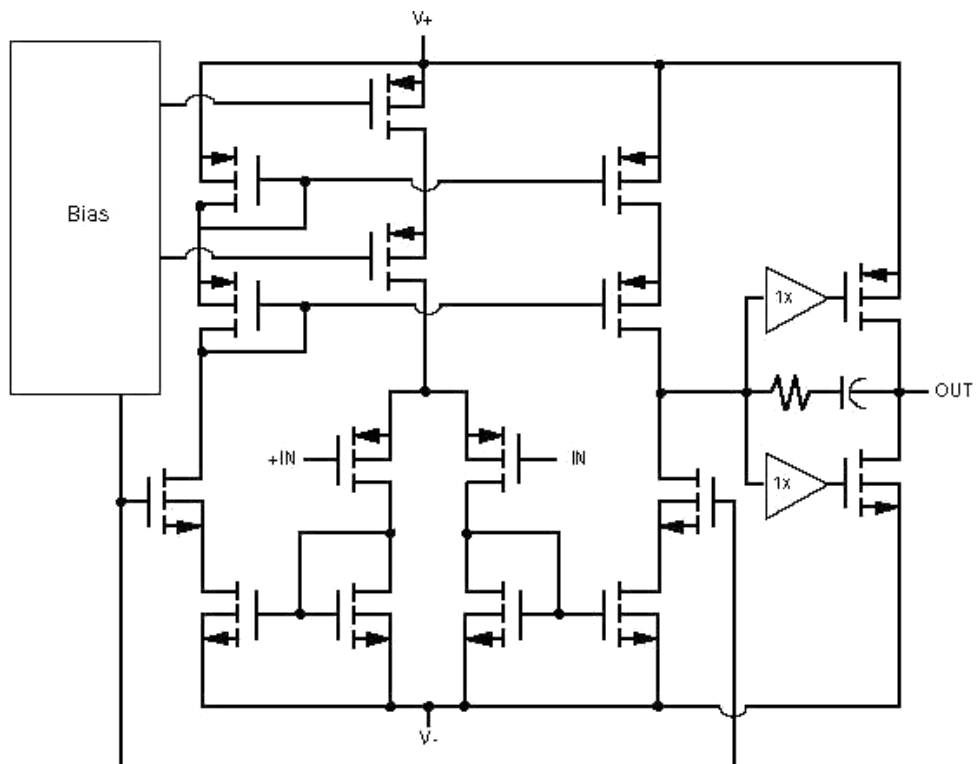

HT1104

PACKAGE DETAIL

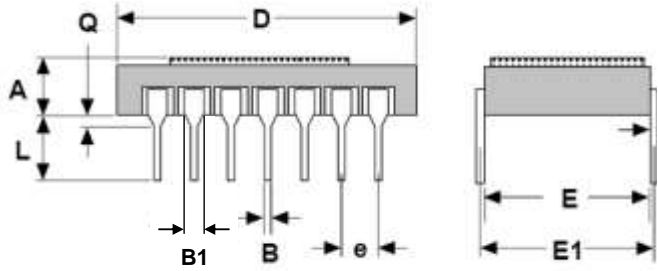

All dimensions in inches
Leads are NiFE (Alloy 42)

A	0.150 (max)
B	0.018 ± 0.002
C	0.010 ± 0.002
D	0.700 ± 0.010
E	0.295 REF
E1	0.300 ± 0.010
B1	0.047 ± 0.002
e	0.100 ± 0.005
L	0.125 ± 0.180
Q	0.035 ± 0.010

DIE DETAIL

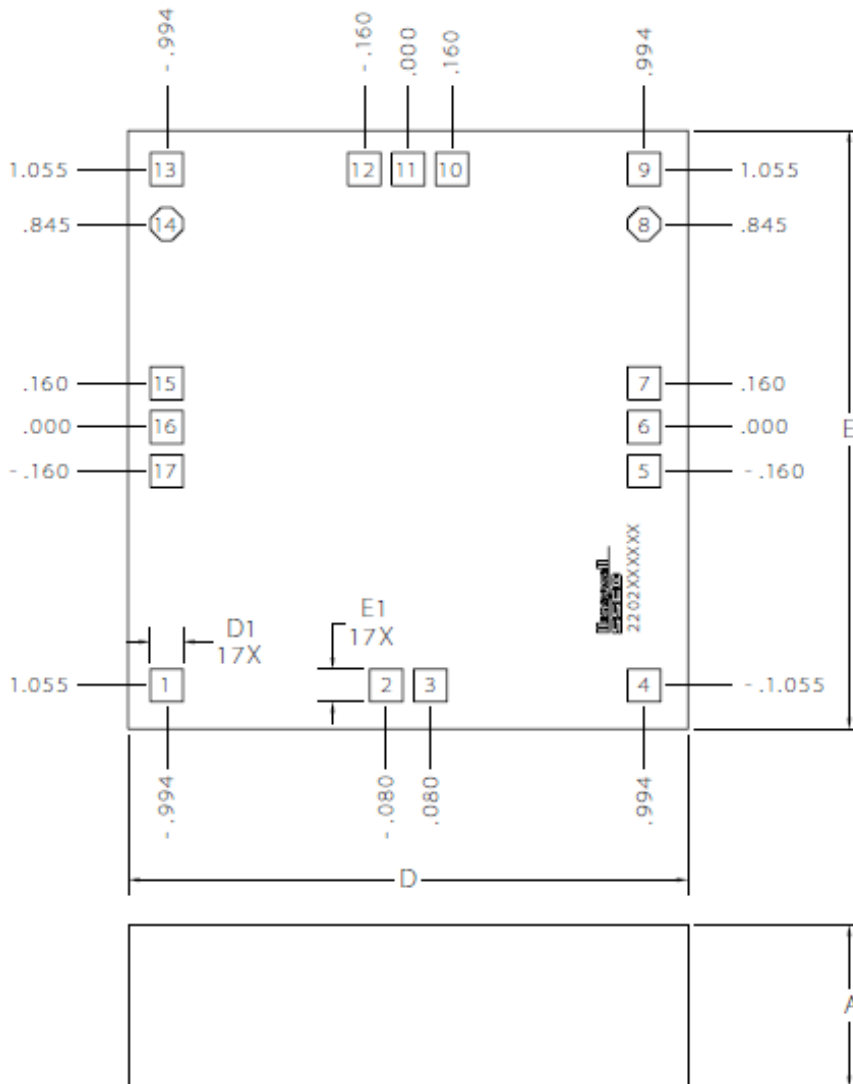

Die Dimension (millimeters)

	Min.	Nom.	Max.
A	0.655	0.675	0.695
D	---	2.455	---
E	---	2.575	---
D1	---	0.100	---
E1	---	0.100	---

Terminal Connections for Die

Die Pad Number	Terminal Connection
1	IN2M
2	OUT2
3	OUT3
4	IN3M
5	IN3P
6	VN*
7	IN4P
8	Do not connect
9	IN4M
10	OUT4
11	VN*
12	OUT1
13	IN1M
14	Do not connect
15	IN1P
16	VP
17	IN2P

1. Die backside is isolated from topside. Die backside shall be externally connected to VN potential.
2. Top-side bond-pad surface metalization is aluminum.
3. Die back-side surface is gold.

*Die pads 6 and 11, VN, are electrically common, by on-chip interconnect.

TYPICAL PERFORMANCE PLOTS

SUPPLY CURRENT vs. TEMPERATURE

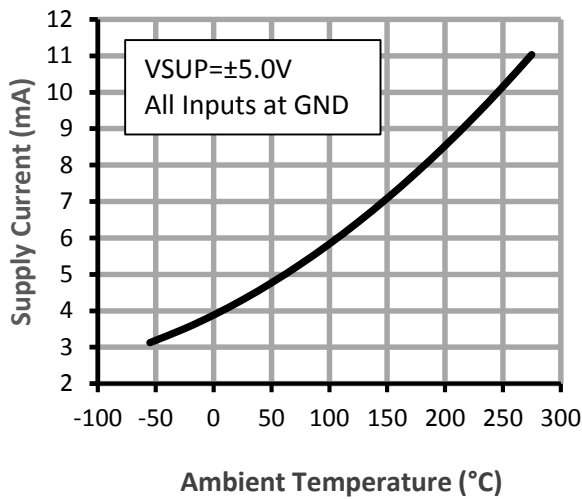

SLEW RATE vs. TEMPERATURE

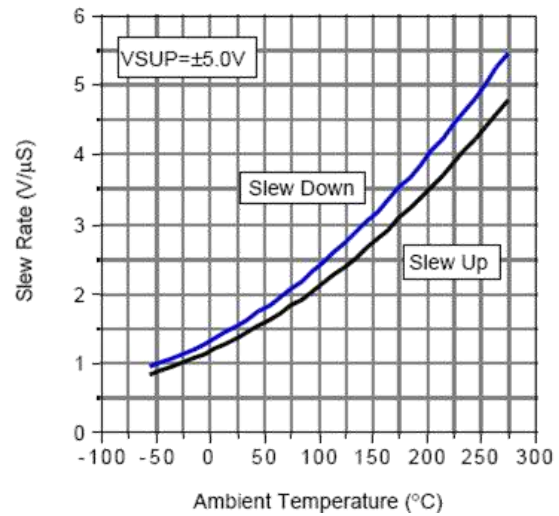

OPEN LOOP GAIN and PHASE vs. FREQUENCY

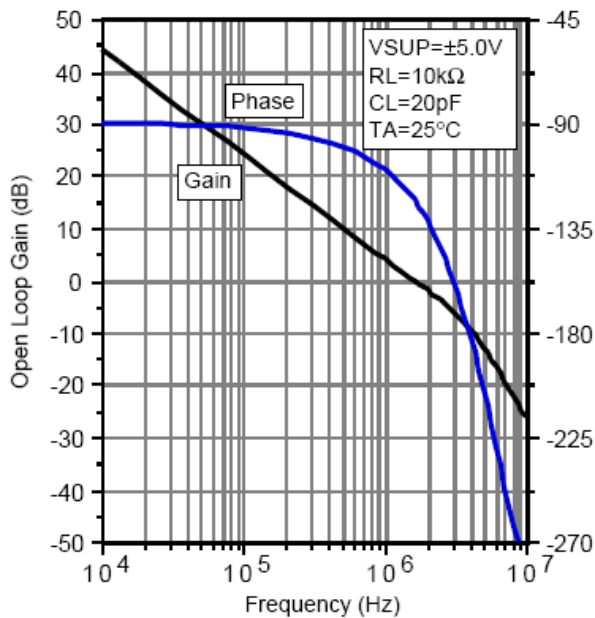

OPEN LOOP GAIN and PHASE vs. FREQUENCY

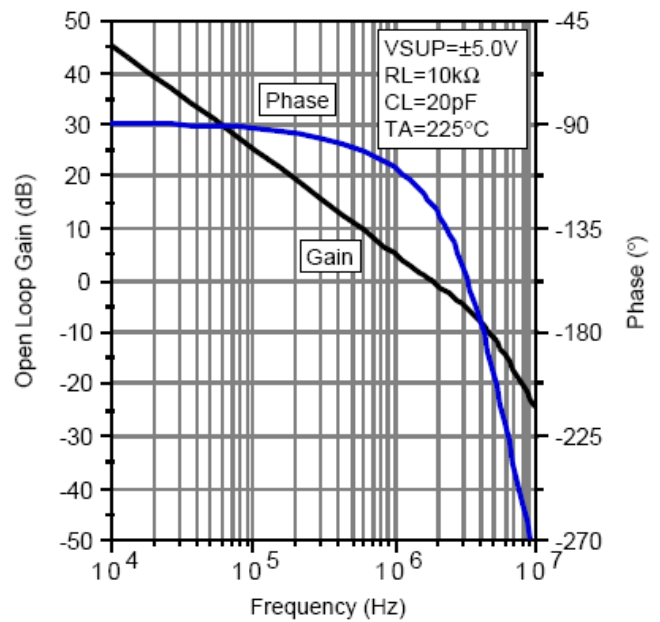

OPEN LOOP GAIN and PHASE vs. FREQUENCY

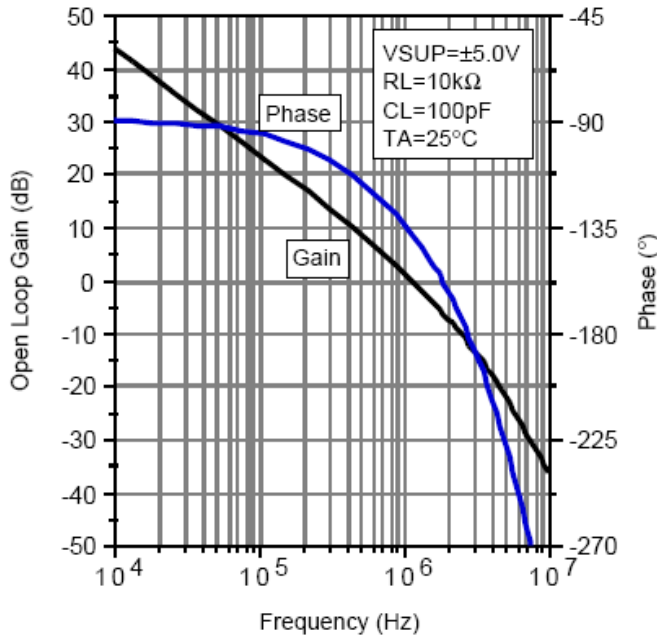

OPEN LOOP GAIN and PHASE vs. FREQUENCY

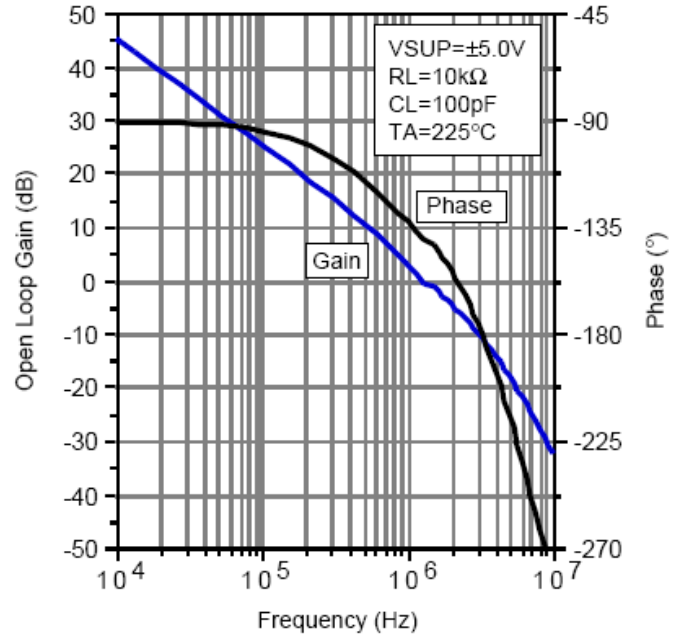

OPEN LOOP GAIN and PHASE vs. FREQUENCY

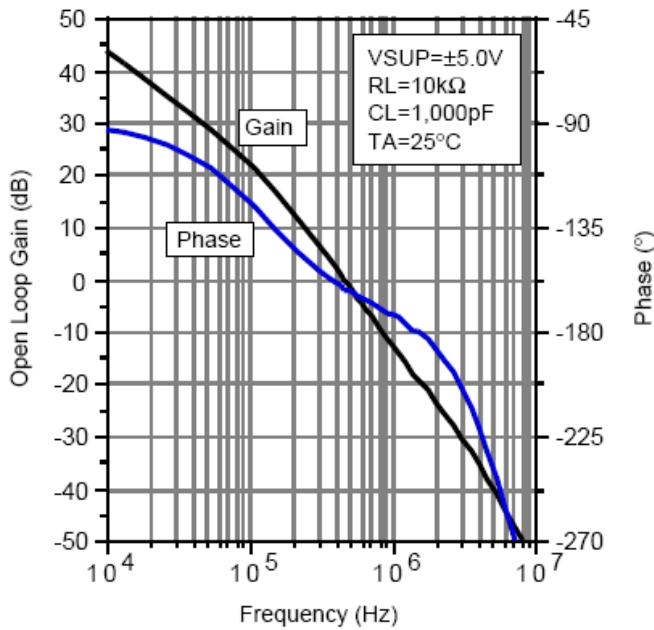

OPEN LOOP GAIN and PHASE vs. FREQUENCY

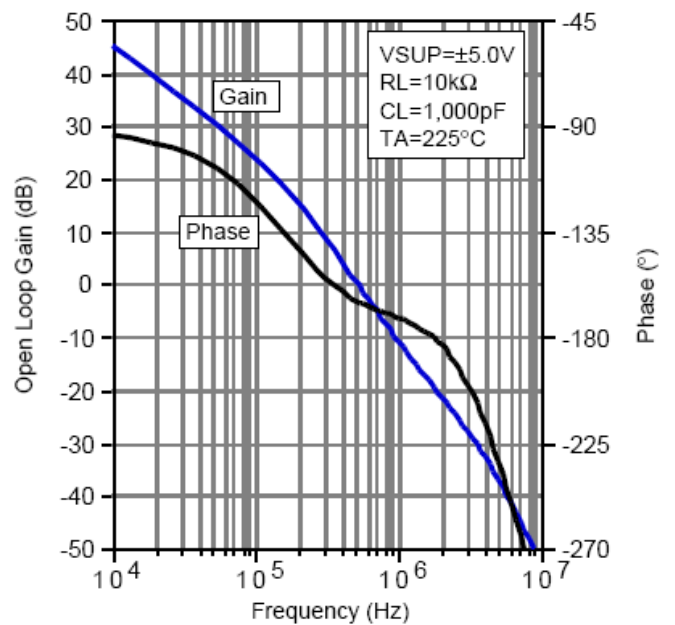

COMMON MODE REJECTION RATIO vs. FREQUENCY

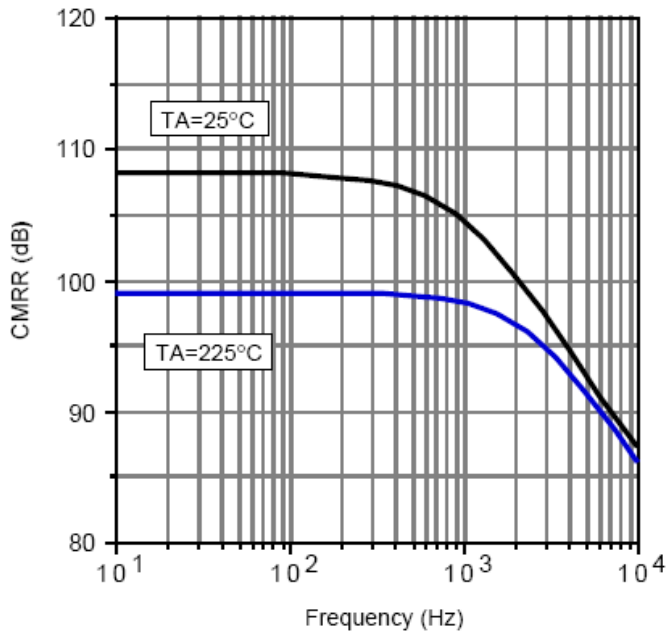

OPEN LOOP GAIN vs. FREQUENCY

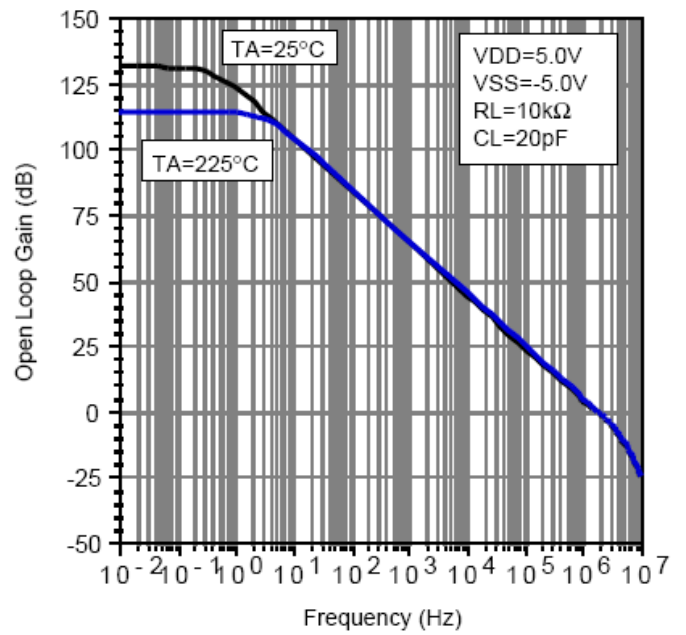

MAXIMUM OUTPUT SWING vs. LOAD CURRENT

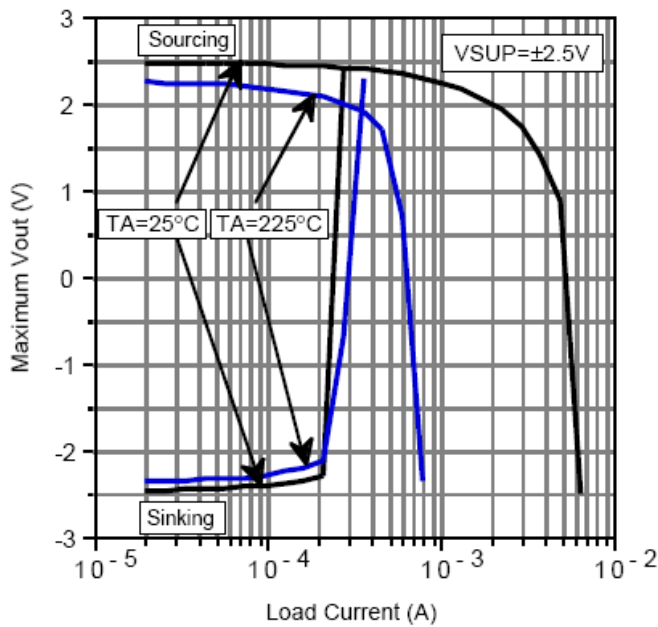

MAXIMUM OUTPUT SWING vs. LOAD CURRENT

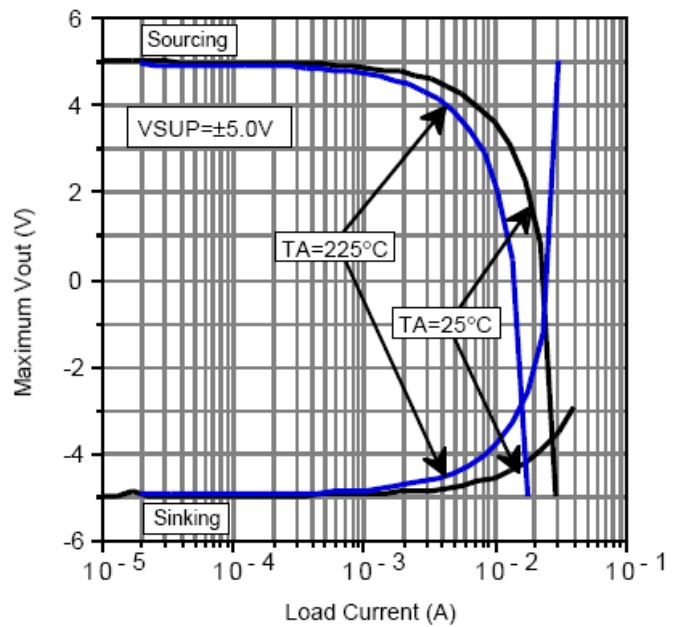

POSITIVE POWER SUPPLY REJECTION vs. FREQUENCY

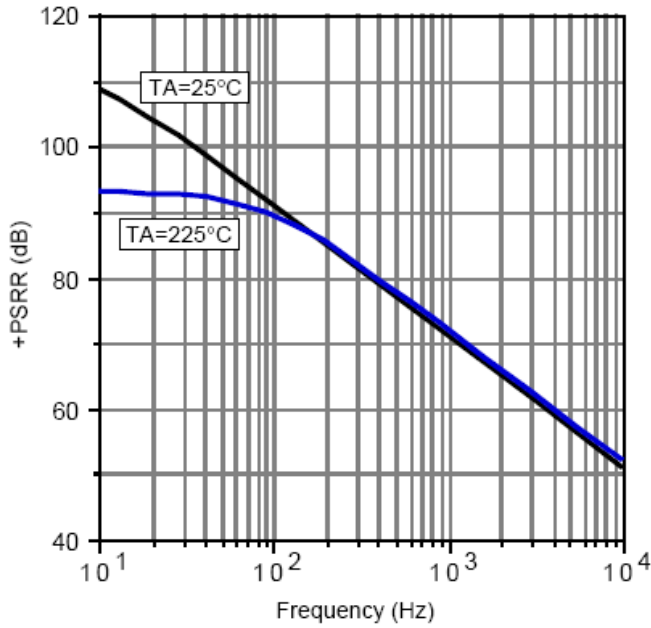

NEGATIVE POWER SUPPLY REJECTION vs. FREQUENCY

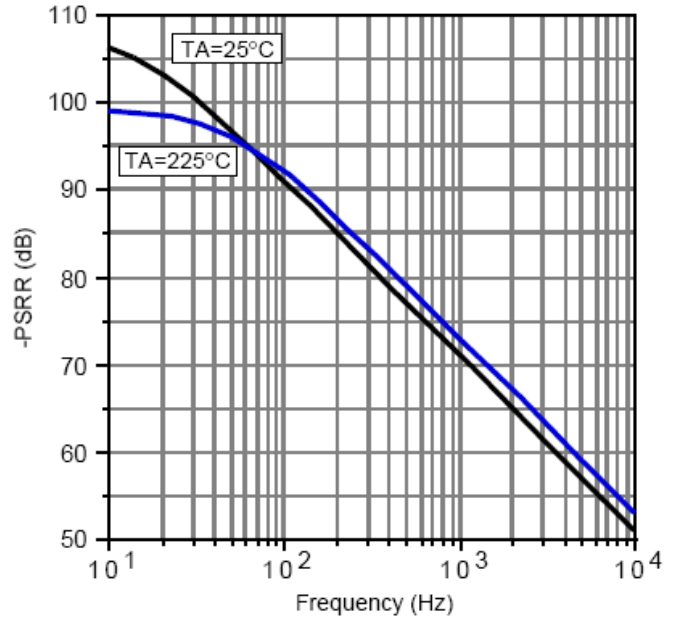

UPPER COMMON MODE LIMIT vs. TEMPERATURE

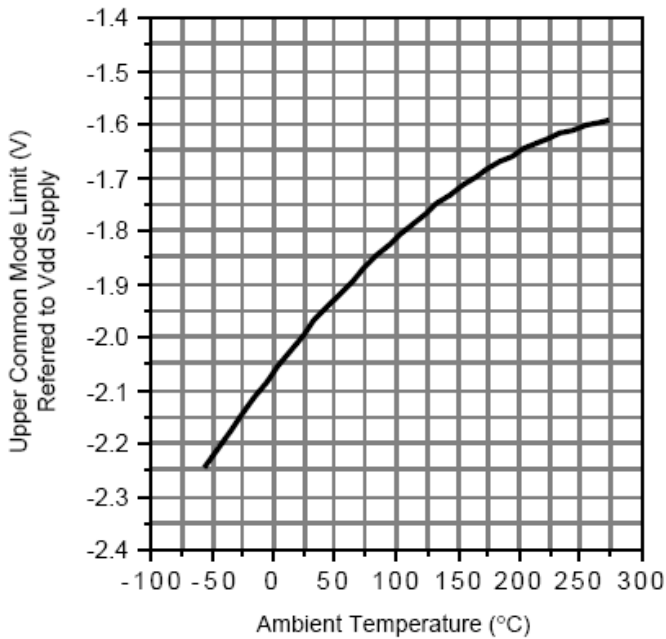

INPUT REFERRED NOISE VOLTAGE vs. FREQUENCY

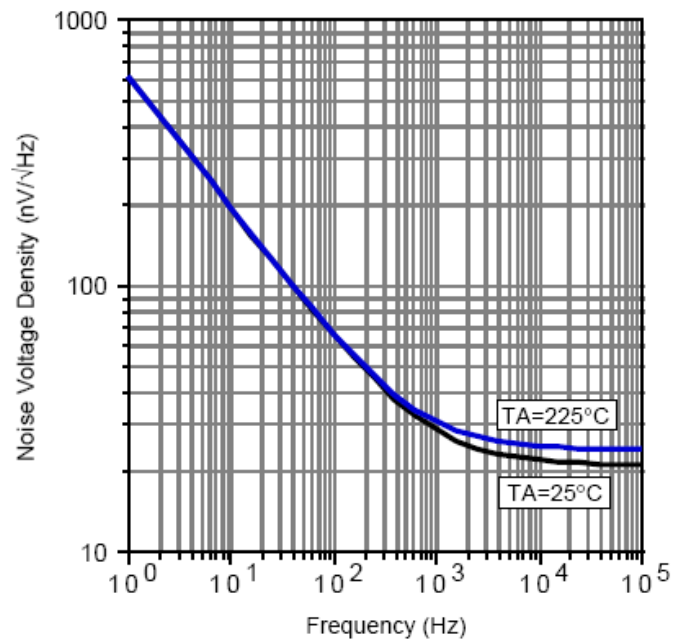

Small Signal Step Response

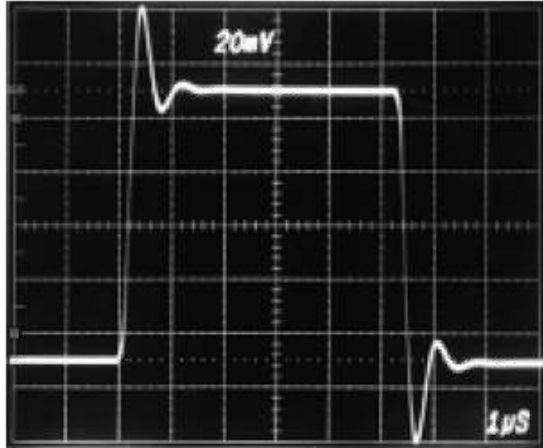

TA=225°C, CL=100pF
Small Signal Step Response

Large Signal Step Response

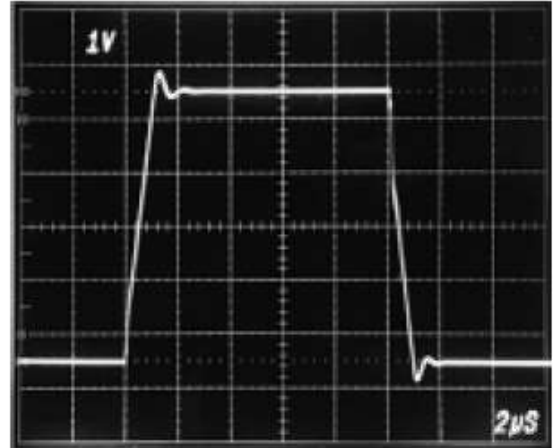

TA=225°C, CL=100pF
Large Signal Step Response

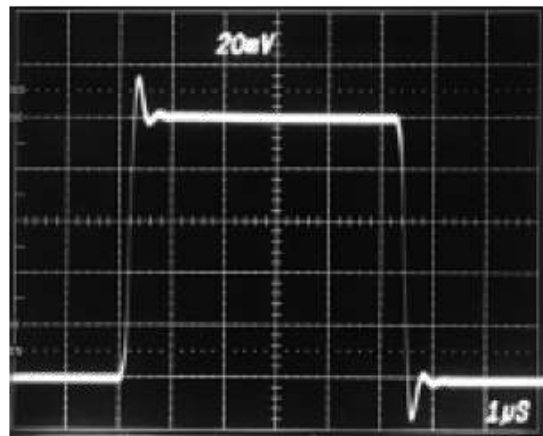

TA=225°C, CL=20pF
SMALL SIGNAL PULSE RESPONSE

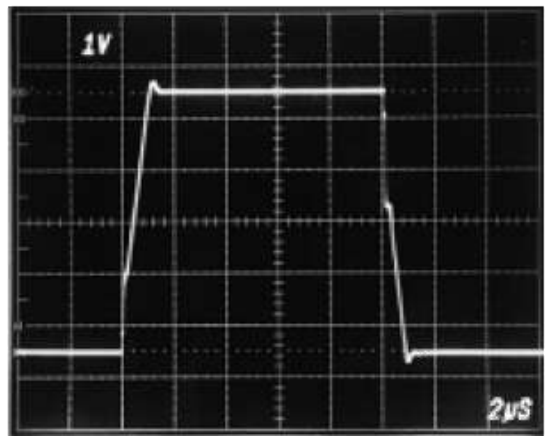

TA=225°C, CL=20pF
SMALL SIGNAL PULSE RESPONSE

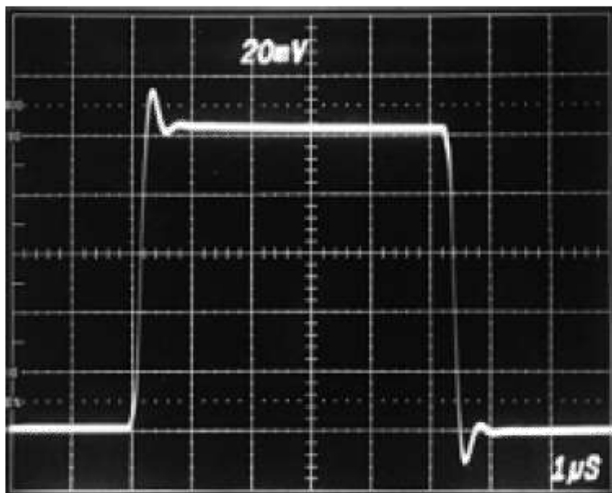

TA=25°C, CL=20pF, Av=+1

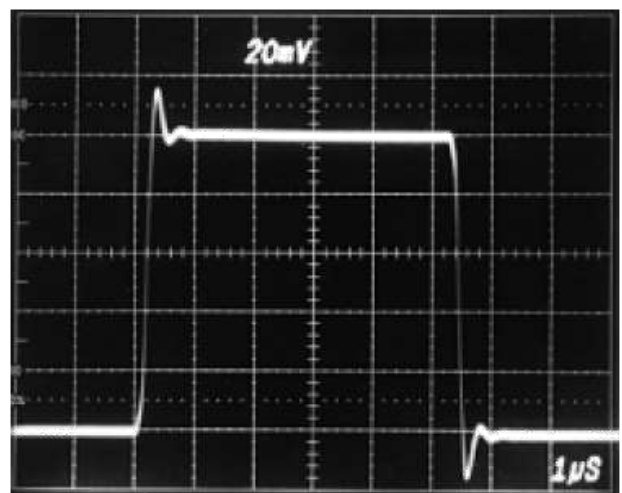

TA=225°C, CL=20pF, Av=+1

HT1104

Small Signal Step Response

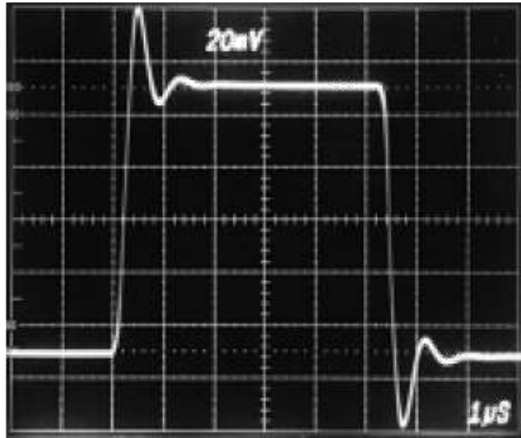

TA=25°C, CL=100pF

Large Signal Step Response

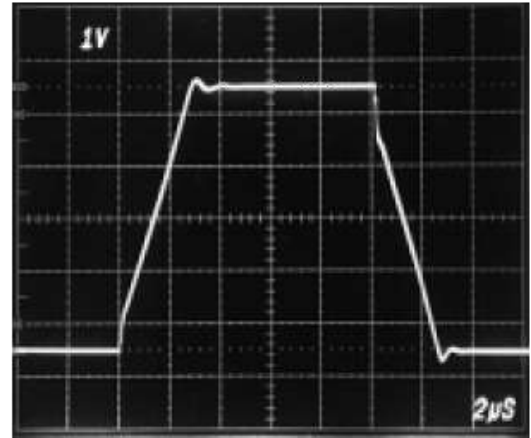

TA=25°C, CL=100pF

DIE LEVEL SCREENING

The HT1104 die are specified to operate over the entire temperature range. To meet this objective, three levels of screening are in place.

1. Wafer Level – 100% of die are electrically tested at room temperature.
2. Sample Package Test – A sample of die from each wafer are assembled into packages and screened over the temperature range of -55C to +225C to verify performance.
3. The sample packaged parts also receive 44 hours of burn-in at 250C.

DIE LEVEL ASSEMBLY RECOMMENDATIONS

Die Bonding

Honeywell recommends using a Eutectic Gold/Silicon preform or high temperature conductive adhesive for die bonding to a ceramic package.

Wire Bonding

1. Aluminum bond wires must be used to achieve high temperature reliability.
2. Wire bond power (die pad 16) and ground (die pads 6 and 11) pads before the other signal pads.

ORDERING INFORMATION

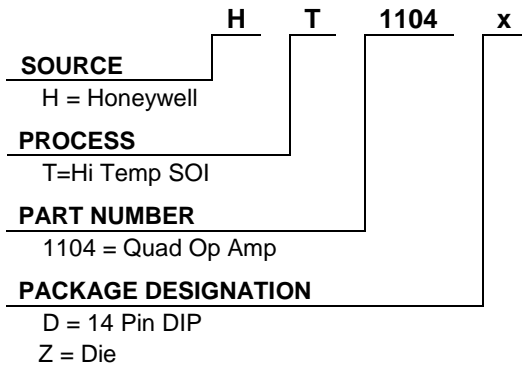
**Find out more**

For more information on Honeywell's High Temperature Electronics visit us online at www.hightempsolutions.com, or contact us at 1-800-323-8295. Customer Service Email: ps.customer.support@honeywell.com.

Honeywell reserves the right to make changes of any sort without notice to any and all products, technology and testing identified herein. You are advised to consult Honeywell or an authorized sales representative to verify that the information in this data sheet is current before ordering this product. Absent express contract terms to the contrary, Honeywell does not assume any liability of any sort arising out of the application or use of any product or circuit described herein; nor does it convey any license or other intellectual property rights of Honeywell or of third parties.

Honeywell

Honeywell
12001 Highway 55
Plymouth, MN 55441
Tel: 800-323-8295
www.hightempsolutions.com

ADS-14254 Rev B
November 2015
©2015 Honeywell International Inc.

单击下面可查看定价，库存，交付和生命周期等信息

[>>Honeywell\(霍尼韦尔\)](#)