

### FEATURES

- 宽输入电压：6V~40V
- 大输出电流：300mA
- 固定输出：5V(Fixed)
- 超低功耗设计
- 快速瞬态响应
- 高输出电压精度
- 平稳启动 (Smooth Start)
- 过流保护 (OCP)
- 过温保护 (TSD)
- 短路保护 (SCP)
- 宽温度范围工作：-40~125°C

### APPLICATIONS

- 工业、汽车及仪器应用
- 便携电池供电设备
- 智能电表、水表
- 车身控制模块
- 汽车LED照明
- 电子娱乐设备

### DESCRIPTION

HNLPD65TM专门为各种需要低功耗、宽输入电压应用而设计。该LDO的低功耗和耐高压输入以及大输出电流设计使得其非常适用于众多的场合，比如智能电表、水表和各类便携电池的供电设备。其宽温度的工作范围也适用各种温度下需要稳定电压的场景。如工业、汽车及各类仪器等电子设备。在这些应用中，高度集成的功能特性使该芯片具有节省成本的优势并大大提高了应用的可靠性。

HNLPD65TM能满足高电压和大电流需求，其优异的瞬态响应性能也将极其适合各种电压变化的场合。由于其自身的低功耗及优异的性能亦非常适用于低功耗的工业和消费类应用。

HNLPD65TM采用TO-252封装。

所有HONGWANSEMI的产品将采用无铅的绿色封装，更具体的情况请到官方网站查询。

### TYPICAL APPLICATION

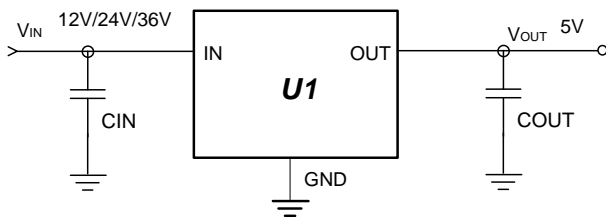

### PACKAGE PLAN



TO252-3

### PIN SEQUENCE (TOP)

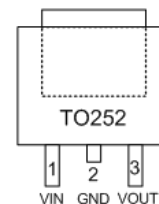

## 1. Pin Configuration (TOP VIEW)

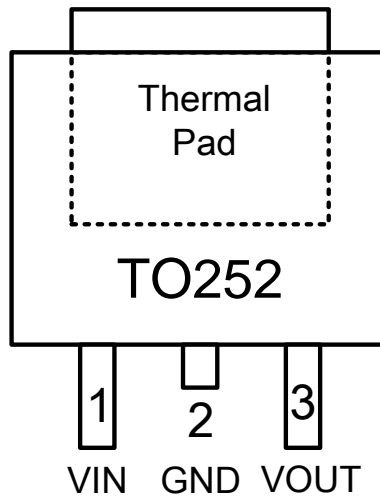

### Pin Description

NO.	Pin Name	Type	Description
TO252			
1	VIN	I	LDO电源电压输入引脚
2	GND	P	接地引脚
3	OUT	O	LDO输出引脚
Thermal Pad	TPad	—	Thermal Pad

## 2. Absolute Maximum Ratings

Symbol	Parameter	Value	Units
$V_{IN}$	Input Supply Voltage	45	V
$V_{OUT}$	Output Voltage	6	
$T_A$	Operating Temperature	-40 ~ 125	°C
$T_{STG}$	Storage Temperature	-40 ~ 150	
$T_J$	Maximum Junction Temperature	150	
$T_{LEAD}$	Lead Temperature (Soldering) 10 seconds	260	
$\theta_{JA}$	Thermal Resistance, Junction-to-Ambient	65	°C/W
$\theta_{JC}$	Thermal Resistance, Junction-to-Case	40	°C/W

注: 使用需注意额定功率, 超出极限参数所规定的范围将对芯片造成无法预估的损害, 在标出条件范围外的工作状态及长期工作在标称条件范围外, 会大大影响芯片的可靠性, 故不推荐在极限条件下应用。

## 3. Function Block Diagram

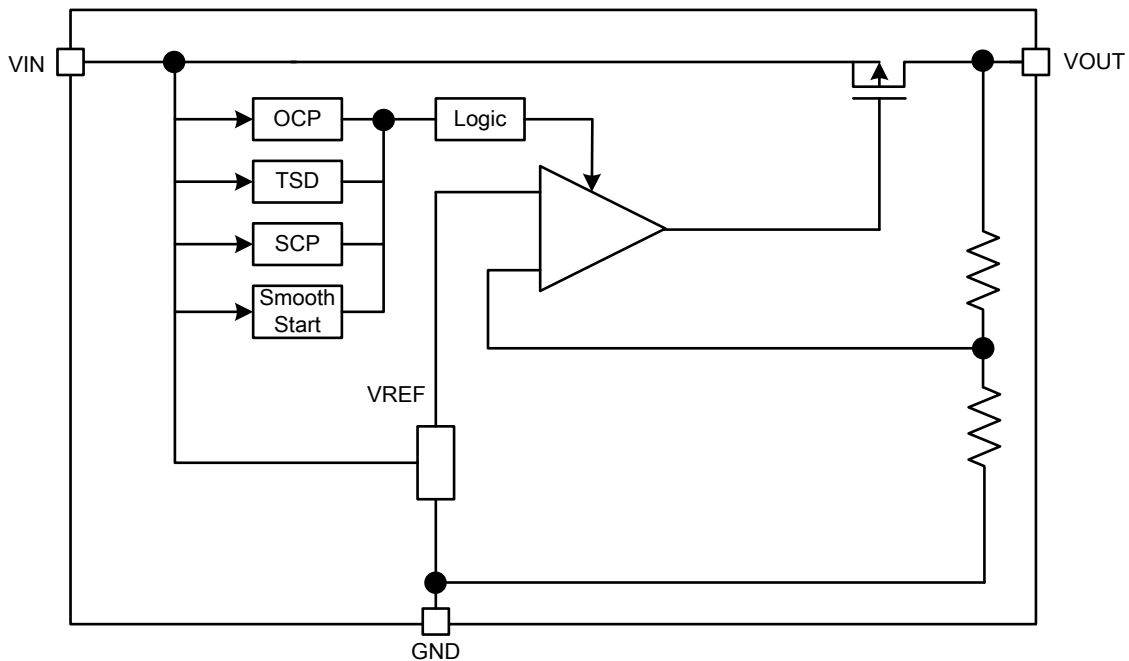

## 4. Electrical Characteristics

( $V_{IN}=V_{OUT}+1V$ ;  $V_{OUT}=5V$ ;  $T_j=25^{\circ}C$ ; unless otherwise noted.)

Symbol	Parameter	Conditions	Min	Typ	Max	Unit
$V_{IN}$	Input Supply Voltage		6		40	V
$V_{OUT}$	Output Voltage Accuracy	$I_{OUT}=10mA$	-2%		2%	V
$I_Q$	Quiescent Current	$V_{IN}=12V$ ; No load		6.5		$\mu A$
$I_{OUT}$	Output Current		0		300	mA
$V_{DRO}^{(1)}$	Dropout Voltage	$I_{OUT}=1mA$ $\Delta V_{OUT} = -V_{OUT} * 2\%$		90	160	mV
		$I_{OUT}=10mA$ $\Delta V_{OUT} = -V_{OUT} * 2\%$		125	265	mV
		$I_{OUT}=100mA$ $\Delta V_{OUT} = -V_{OUT} * 2\%$		1180	1785	mV
$\Delta V_{O(\Delta I_O)}$	Load Regulation	$1mA \leq I_{OUT} \leq 300mA$		60		mV
$\Delta V_{O(\Delta V_I)}$	Line Regulation	$I_{OUT}=10mA$ , $V_{IN}=(V_{OUT}+1V)$ to 40V		30		mV
$I_{LIM}$	Current Limit	$V_{IN}=(V_{OUT}+1V)$ to 40V		Internal Limited		mA
$T_{TSD}$	Thermal Protection	Temp increasing		150		$^{\circ}C$
		Temp hysteresis		20		
$TC_{V_{OUT}}^{(2)}$	Output Voltage Temperature Coefficient	$I_{OUT}=10mA$ $-40^{\circ}C \leq T_{AMB} \leq 125^{\circ}C$		$\pm 100$		ppm/ $^{\circ}C$

Note :

- The dropout voltage is defined as  $V_{IN} - V_{OUT}$ , when  $V_{OUT}$  is drop 2% of the value of  $V_{OUT}$  for  $V_{IN} = V_{OUT} + 2V$ .
- Output voltage temperature coefficient is defined as the worst-case voltage change divided by the total temperature range.  $TC_{V_{OUT}} = \Delta V_{OUT} / (V_{OUT} \times \Delta T)$
- Operation outside the nominal condition range will greatly affect the reliability of the chip. Not recommended to apply it under the limit conditions. Used the chip under the Power  $(Max)$ .

## 5. Package Information

Dimensions Symbol	Min.(mm)	Typ.(mm)	Max.(mm)
A	6.50	6.60	6.70
A1	0.64	--	0.74
A2		2.286 TYP	
A3		4.572 TYP	
B	6.00	6.10	6.20
B1	9.95	--	10.25
B2	1.06	--	1.16
C	2.15	2.25	2.35
C1	0.00	--	0.10
C2	0.375	--	0.45
D		3.166 REF	
E		4.826 REF	
L	1.45	1.55	1.65
$\theta 1$	0°	—	8°
$\theta 2, \theta 3$		10° TYP	
$\theta 4$		8.5° TYP	
$\theta 5$		70° TYP	

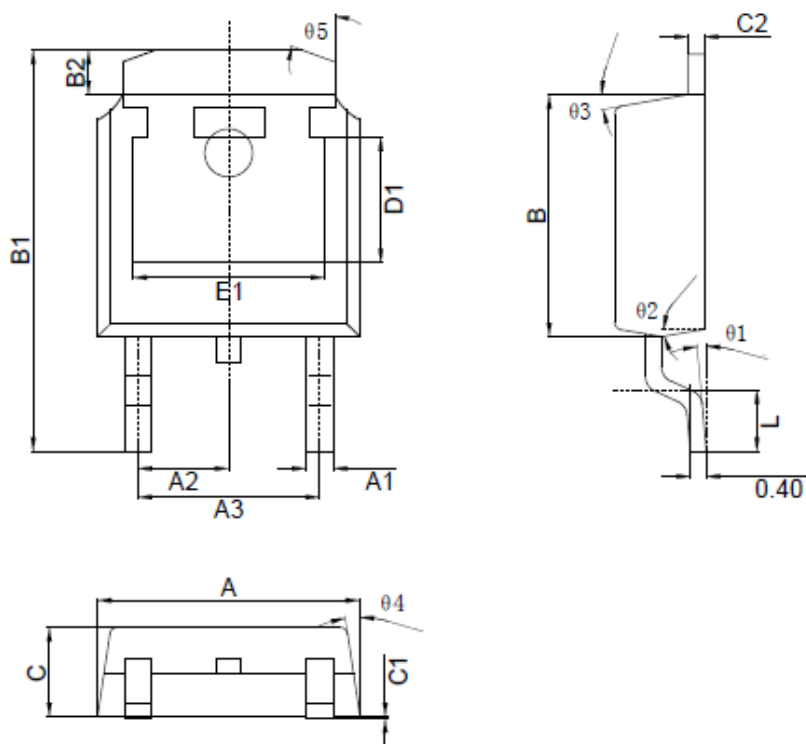

**免责声明：** 本文件中的信息仅与弘湾半导体（以下简称“HW”）产品相关。弘湾半导体及其子公司保留随时对本文件以及本文所述的产品和服务进行更改、更正、修改或改进的权利，恕不另行通知。买方自行承担本文件所述HW产品和服务的认定、选择和使用的全部责任，HW不承担任何与本文所述HW产品和服务的认定、选择使用有关的责任。转售与本文件中陈述和/或技术特征不同的HW产品会立即失效。

单击下面可查看定价，库存，交付和生命周期等信息

[>>HONGWAN\(弘湾半导体\)](#)