

Recommended P/N 20374-R**E-31

PART NO.	POS.	A	B	C	D	E
20374-R10E-31	10	3.60	7.60	9.60	7.20	5.50
20374-R14E-31	14	5.20	9.20	11.20	8.80	5.50
20374-R20E-31	20	7.60	11.60	13.60	11.20	8.00
20374-R30E-31	30	11.60	15.60	17.60	15.20	8.00
20374-R32E-31	32	12.40	16.40	18.40	16.00	8.00
20374-R35E-31	35	13.60	17.60	19.60	17.20	8.00
20374-R40E-31	40	15.60	19.60	21.60	19.20	8.00
20374-R50E-31	50	19.60	23.60	25.60	23.20	8.00



Halogen Free



RoHS Compliant

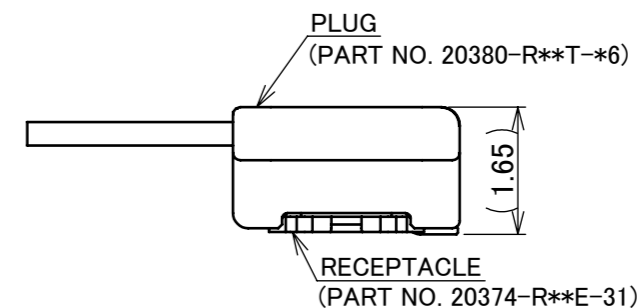
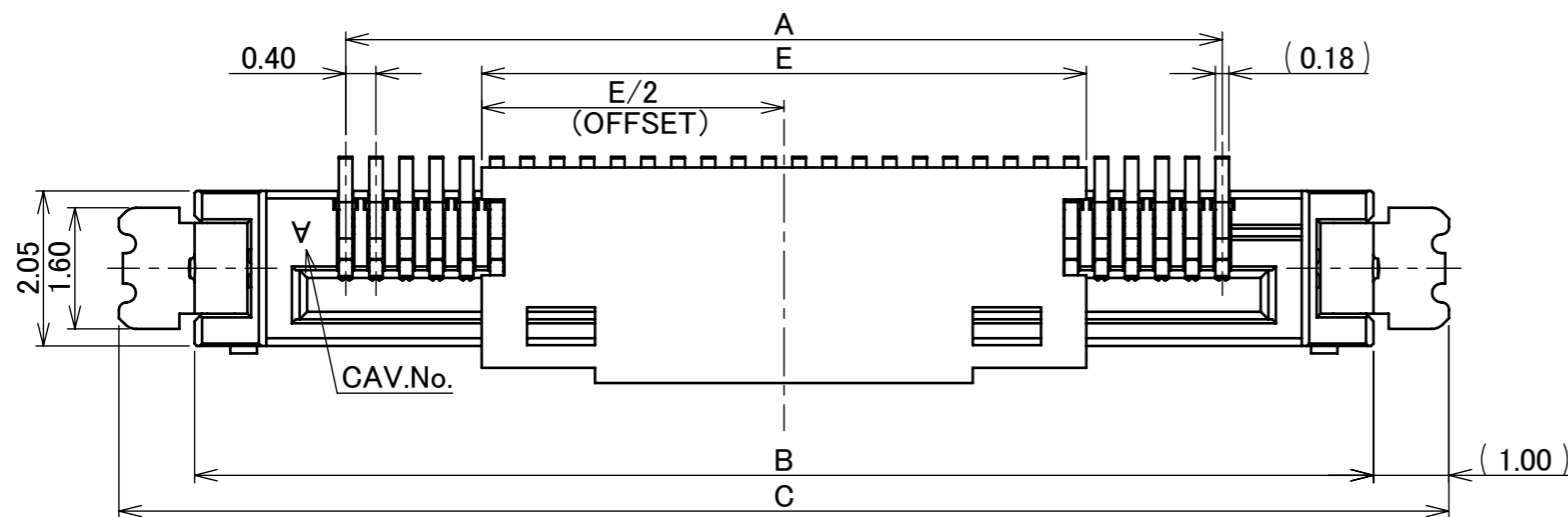

MATING CONDITION

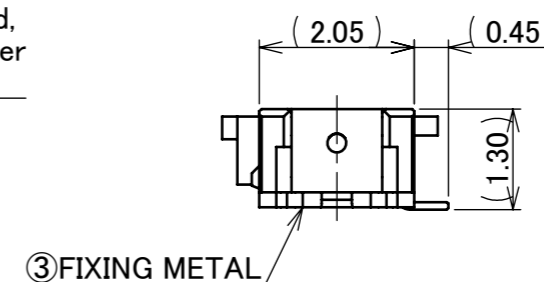
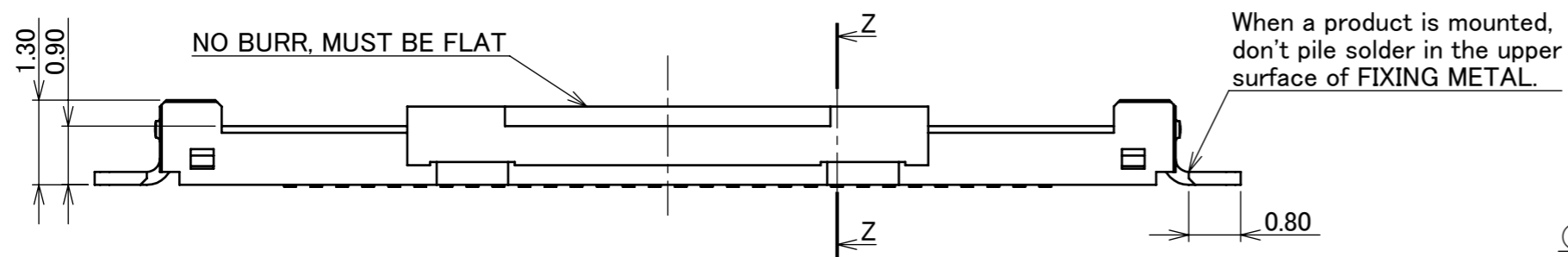

③ FIXING METAL

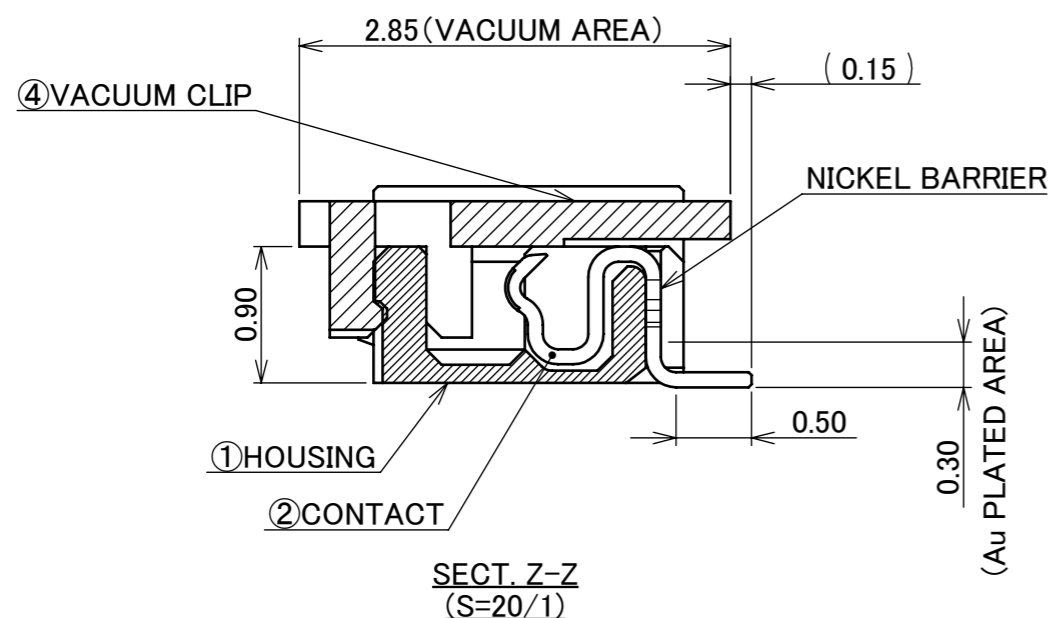

SECT. Z-Z
(S=20/1)

NO.	DISCRIPTION	MATERIAL	FINISH, REMARKS
4	VACUUM CRIP	LCP	UL94V-0, BEIGE
3	FIXING METAL	PHOSPHOR BROZE	Sn/Cu(98/2) (LUSTER) 2.0 μm MIN. OVER Ni 1.00 μm MIN.
2	CONTACT	PHOSPHOR BROZE	CONTACT AREA: Au 0.1 μm MIN. OVER Ni 1.00 μm MIN. SOLDERING AREA: Au 0.05 μm MIN. OVER Ni 1.00 μm MIN.
1	HOUSING	LCP (RED PHOSPHORUS IS NOT USED)	UL94V-0, BLACK

REV.	ECN	BY	DATE	APP.	APP.	PROJECTION	SERIES No.	TITLE	SCALE	SHEET	REV.
30	Z221004	K.Hara	Sept./05/'22	H.I	ANGLE ±2° 6 OVER 30 MAX. ±0.3		R3	CABLINER [®] -SS RECEPTACLE ASS'Y	10:1	A3	30
29	Z220245	TSU	2022/03/08	H.I	6 MAX. ±0.2 30 OVER 120 MAX. ±0.5						
28	Z210420	T.T	Apr./21/'21	H.I	GENERAL TOLERANCE.						
27	Z201182	K.Hara	Nov./13/'20	Y.S	DWG. K.Narita DATE 2004/04/19						
26	Z201151	K.Hara	Nov./05/'20	Y.S	CHK. -						
25	Z181296	H.K	Oct./24/'18	Y.S	APP. -						
REVISION RECORD						T.Harada	20374				

ITEMS	SPECIFICATION
APPLICABLE CABLE	MICRO COAX : AWG# 42 , 40 , 36 DISCRETE : AWG# 36, 34 TWINCOAX : AWG# 40
RATING VOLTAGE	100V AC (PER CONTACT PIN)
RATING AMPERAGE (FOR CONTACT)	0.24A AC/DC [AWG#42] AVAILABLE TO 50 PIN 0.25A AC/DC [AWG#40] AVAILABLE TO 50 PIN 0.30A AC/DC [AWG#40] AVAILABLE TO 32 PIN 0.35A AC/DC [AWG#36] AVAILABLE TO 50 PIN 0.40A AC/DC [AWG#36] AVAILABLE TO 37 PIN 0.35A AC/DC [AWG#34] AVAILABLE TO 50 PIN 1.00A AC/DC [AWG#34] AVAILABLE TO 2 PIN
OPERATING TEMPERATURE	233~358K (-40°C~85°C)
OPERATING HUMIDITY	85% MAX. (NON-CONDENSING)
CONTACT RESISTANCE	INITIAL : 180mohm MAX. (AWG#34) / AFTER TEST : \triangle 40mohm MAX. 275mohm MAX. (AWG#36) 600mohm MAX. (AWG#40) 700mohm MAX. (AWG#42) (INITIAL CONTAINS THE CONDUCTOR RESISTANCE OF A CABLE 100mm)
GROUND SHELL RESISTANCE	INITIAL : 50mohm MAX. / AFTER TEST : \triangle 40mohm MAX.
INSULATION RESISTANCE	INITIAL : 1000Mohm MIN. / AFTER TEST : 500Mohm MIN.
DIELECTRIC WITHSTANDING VOLTAGE	AC250V 1min
DURABILITY	30 CYCLES
MATING FORCE (INITIAL / AFTER 30 CYCLES)	10P : 29.00N MAX. 32P : 33.40N MAX. 14P : 29.80N MAX. 35P : 34.00N MAX. 20P : 31.00N MAX. 40P : 35.00N MAX. 30P : 33.00N MAX. 50P : 38.00N MAX.
UNMATING FORCE	10P : INITIAL : 4.00N MIN. / AFTER 30 CYCLES : 2.87N MIN. 14P : INITIAL : 4.40N MIN. / AFTER 30 CYCLES : 3.23N MIN. 20P : INITIAL : 5.00N MIN. / AFTER 30 CYCLES : 3.76N MIN. 30P : INITIAL : 6.00N MIN. / AFTER 30 CYCLES : 4.65N MIN. 32P : INITIAL : 6.20N MIN. / AFTER 30 CYCLES : 4.84N MIN. 35P : INITIAL : 6.50N MIN. / AFTER 30 CYCLES : 5.07N MIN. 40P : INITIAL : 7.00N MIN. / AFTER 30 CYCLES : 5.50N MIN. 50P : INITIAL : 8.00N MIN. / AFTER 30 CYCLES : 6.41N MIN.
COPLANARITY	0.10 MAX.
PRODUCT SPECIFICATION	PRS-1239
TEST REPORT	TR-04037
PACKING STANDARD	300-359
INSTRUCTION MANUAL	HIM-04001
APPEARANCE CRITERIA No.	QLS-A***

ANGLE	$\pm 2^\circ$	6 OVER 30 MAX.	± 0.3	PROJECTION 	SERIES No. R3	CUSTOMER COPY		
6 MAX.	± 0.2	30 OVER 120 MAX.	± 0.5			SCALE -	I-PEX	
GENERAL TOLERANCE.				TITLE CABLIN [®] -SS RECEPTACLE ASS'Y		UNIT mm		
DWG.	DATE			DWG. No. 20374		SIZE A3		
CHK.								
APP.								

PART NO.	POS.	A	D
20374-R10E-31	10	3.60	7.20
20374-R14E-31	14	5.20	8.80
20374-R20E-31	20	7.60	11.20
20374-R30E-31	30	11.60	15.20
20374-R32E-31	32	12.40	16.00
20374-R35E-31	35	13.60	17.20
20374-R40E-31	40	15.60	19.20
20374-R50E-31	50	19.60	23.20

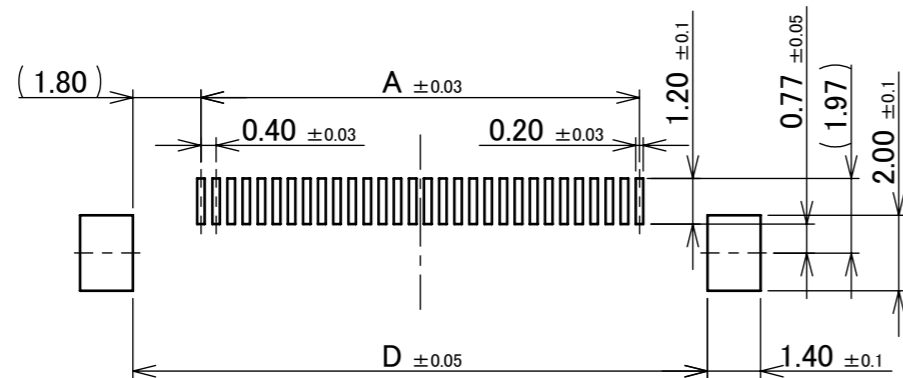

RECOMMENDED FOOTPRINT PATTERN (MOUNT SIDE)

Recommended Thickness of Metal Mask : $t=0.13\text{mm}$
 Recommended Opening Ratio of Metal Mask : 79.6%

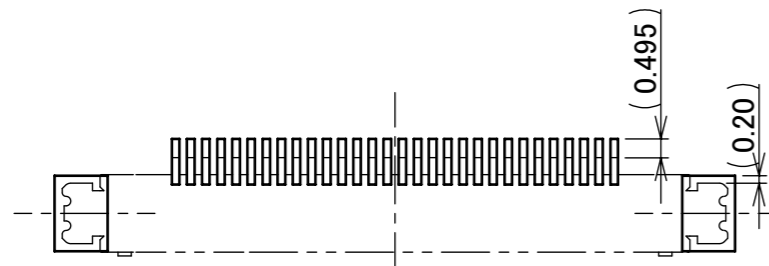

CONNECTOR ON RECOMMENDED FOOTPRINT PATTERN

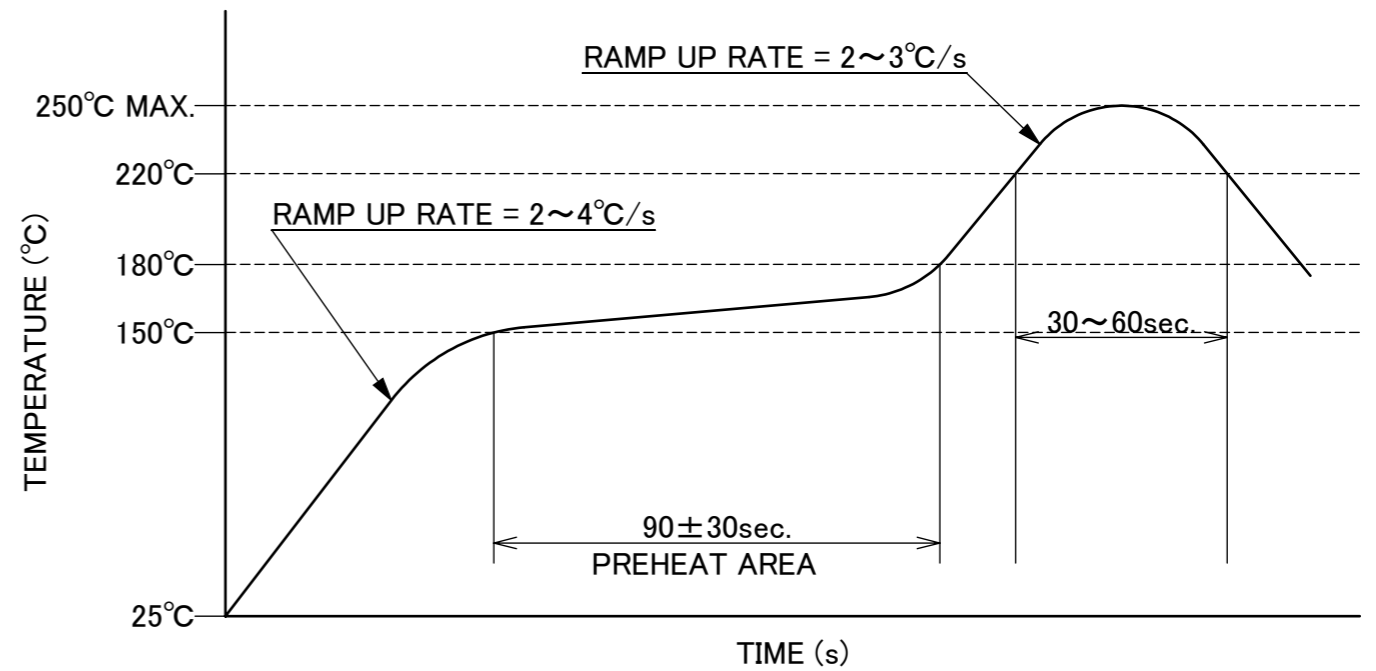

REFLOW TEMPERATURE PROFILE
 SENJU METAL INDUSTRY CO., LTD. : M705-SHF(Sn96.5 Ag3.0 Cu0.5)

ANGLE	$\pm 2^\circ$	6 OVER 30 MAX.	± 0.3	PROJECTION 	SERIES No. R3	CUSTOMER COPY			
	6 MAX.	± 0.2	30 OVER 120 MAX.			± 0.5	SCALE 5:1	I-PEX	
GENERAL TOLERANCE.				TITLE CABLIN [®] -SS RECEPTACLE ASS'Y		UNIT mm			
DWG.	DATE			DWG. No. 20374		SIZE A3	SHEET 3/4	REV. 30	
CHK.									
APP.									

PART NO.	POS.	F	G	H	J	K	L	M	N	QTY. PER EMOSS REEL (PIECES / REEL)	QTY. PER PACKING CARTON (REELS / CARTON)
20374-R10E-31	10	24.00	21.50	11.50	-	9.90	5.90	5.90	2.50	6000 PIECES / REEL	3 REELS / CARTON = 18000 PIECES
20374-R14E-31	14	24.00	21.50	11.50	-	11.50	7.50	7.50	2.50		
20374-R20E-31	20	32.00	26.00	14.20	28.40	14.00	9.00	8.78	2.55		
20374-R30E-31	30	32.00	26.00	14.20	28.40	18.00	12.00	12.78	2.55		
20374-R32E-31	32	32.00	26.00	14.20	28.40	18.80	12.00	13.58	2.55		
20374-R35E-31	35	32.00	26.00	14.20	28.40	20.00	12.00	14.78	2.55		
20374-R40E-31	40	32.00	26.00	14.20	28.40	22.00	12.00	16.78	2.55		
20374-R50E-31	50	44.00	37.00	20.20	40.40	26.00	12.00	20.78	2.55		

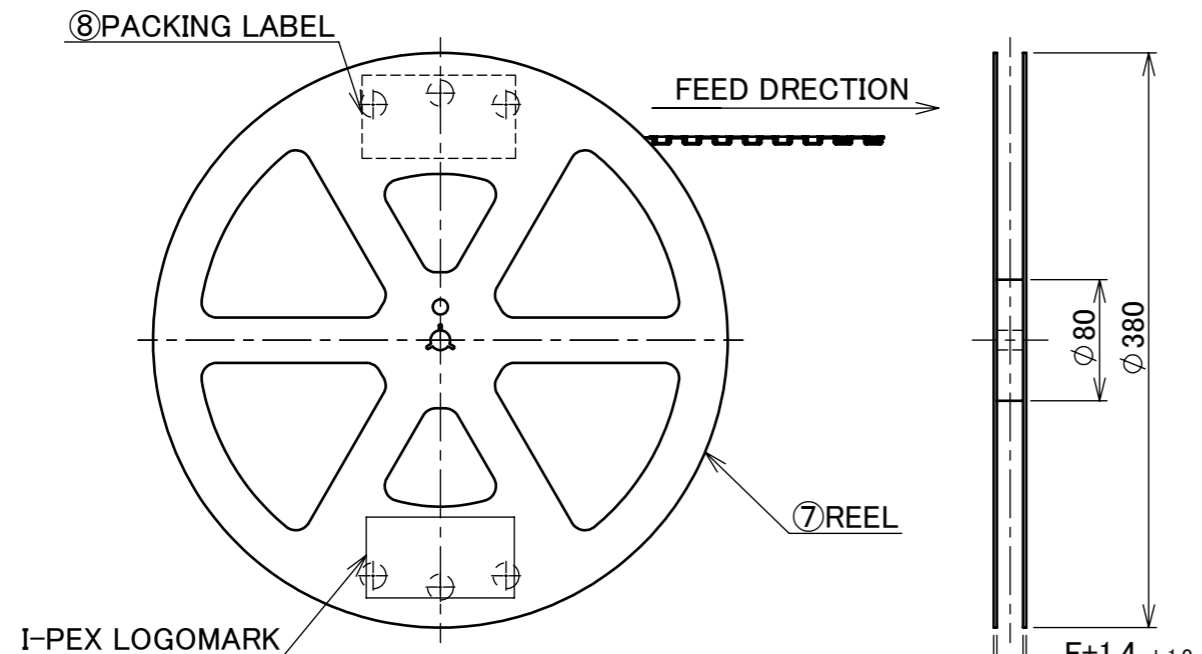

NOTES.
 1. TAPING SPECIFICATION FOLLOWS JIS C 0806 (IEC 60286-3).
 2. MAKE EMPTY SECTION OF LEADER AND END ON EACH END OF THE TAPE.
 3. TOP TAPE SHALL NOT STICK OUT FROM EMOSS TAPE.
 4. TOP TAPE SHALL NOT COVER FEED HOLE.

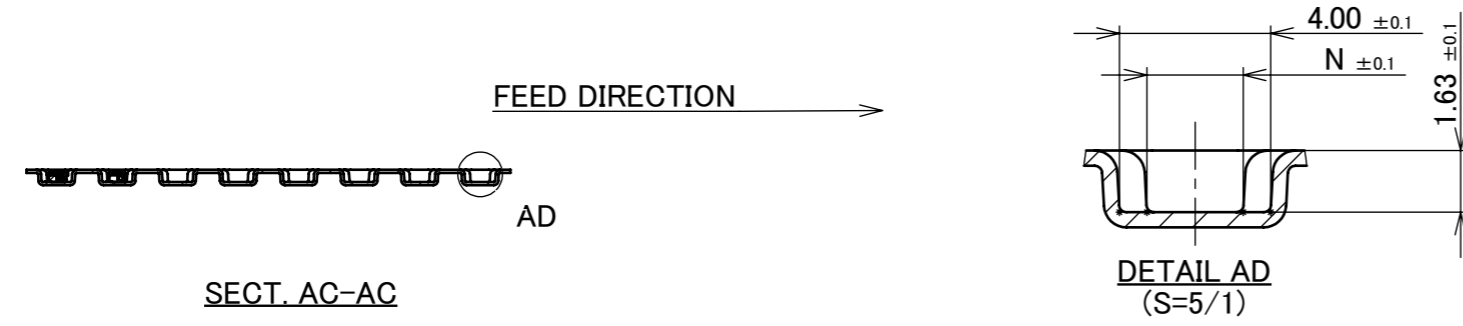
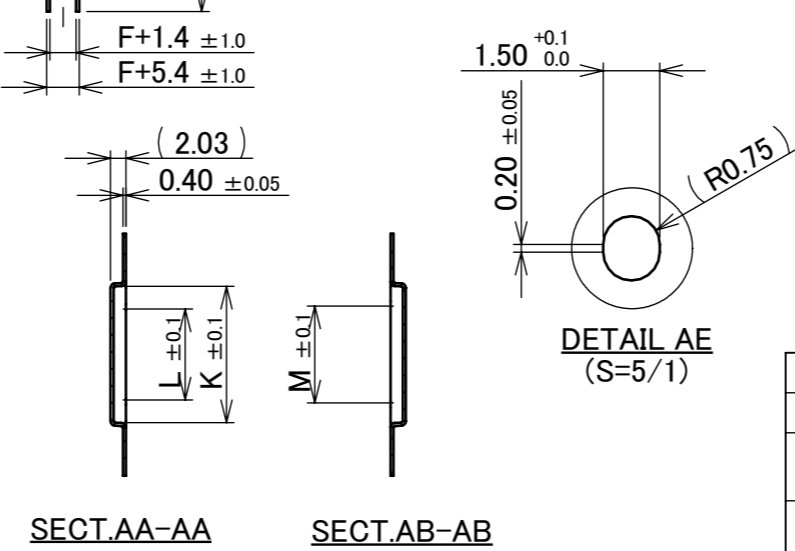
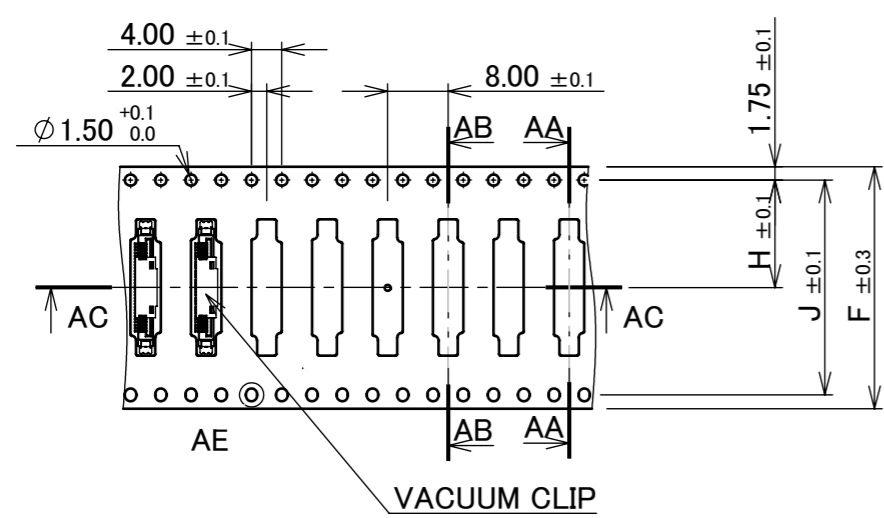
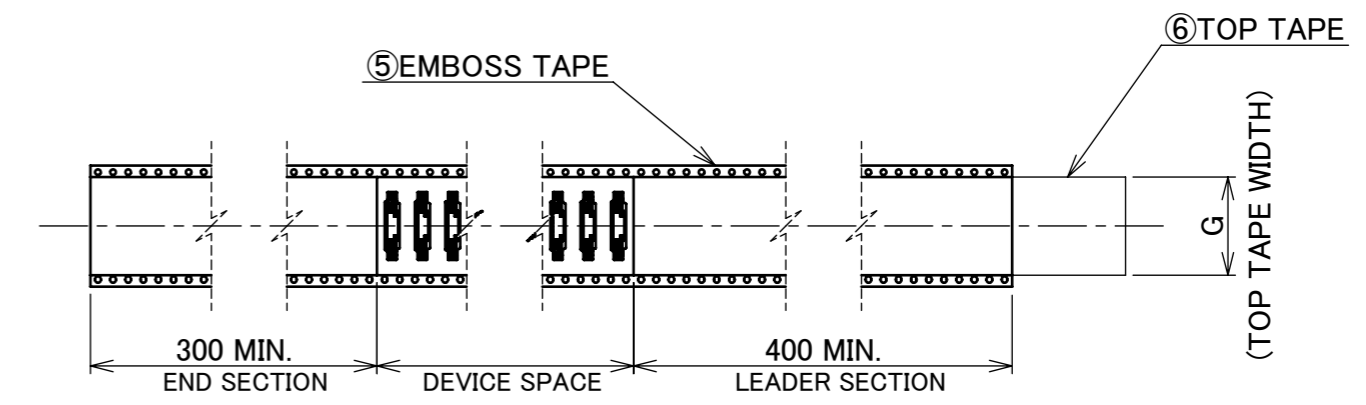

NO.	DISCRIPTION	MATERIAL	FINISH , REMARKS
8	PACKING LABEL	-	-
7	REEL	PS	BLACK
6	TOP TAPE	PET t=0.062 TRANSPARENCY	ANTI-STATIC TYPE
5	EMBOSS TAPE	PS t=0.4 TRANSPARENCY	ANTI-STATIC TYPE

ANGLE	±2°	6 OVER 30 MAX.	±0.3	PROJECTION ①	SERIES No. R3	CUSTOMER COPY
6 MAX.	±0.2	30 OVER 120 MAX.	±0.5			
GENERAL TOLERANCE.				TITLE CABLINER [®] -SS RECEPTACLE ASS'Y	SCALE 1:5	UNIT mm
DWG.	DATE					
CHK.						
APP.						
DWG. No. 20374				SIZE A3	SHEET 4/4	REV. 30

单击下面可查看定价，库存，交付和生命周期等信息

[>>I-PEX](#)