

**ODD NUMBER POS.**

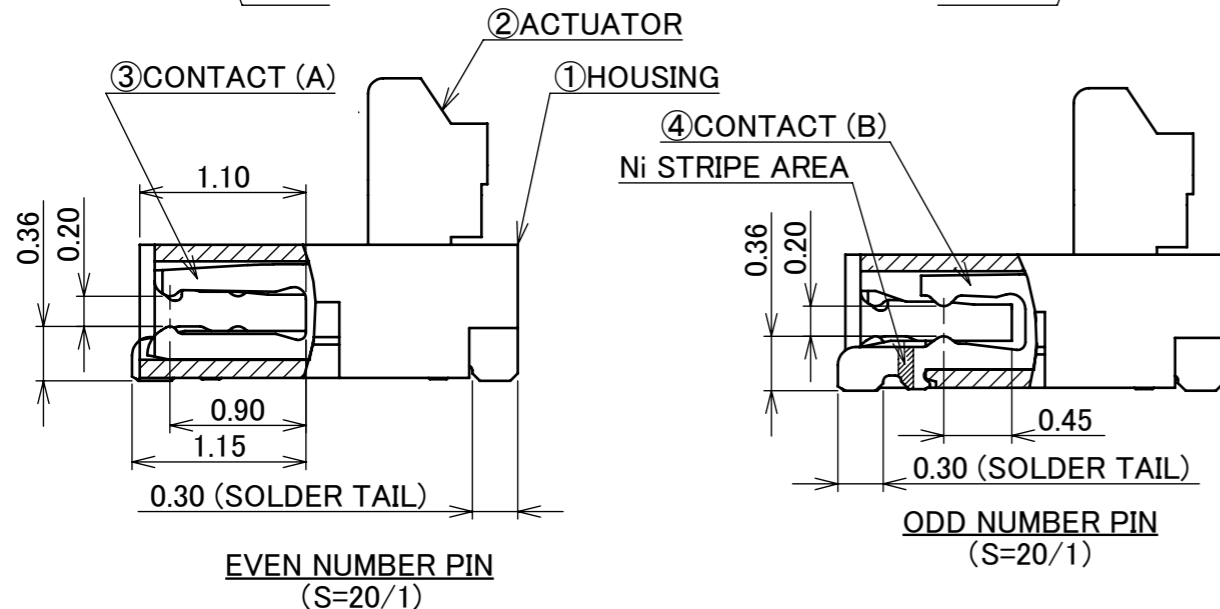
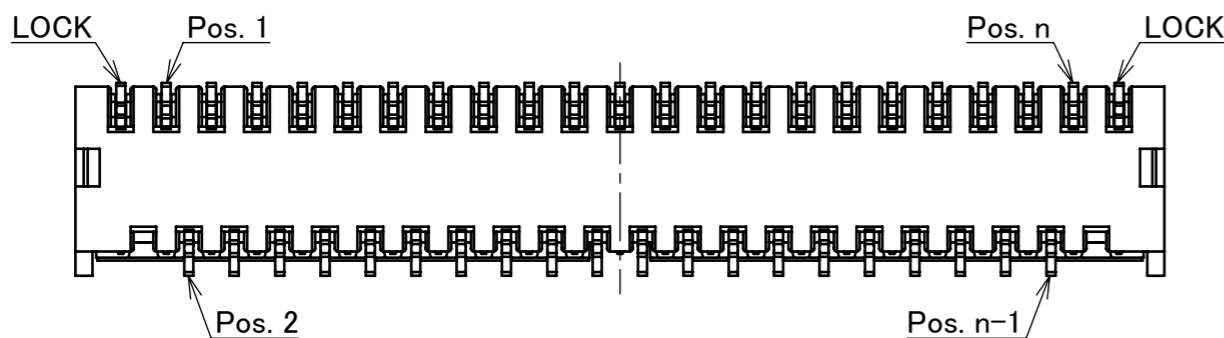
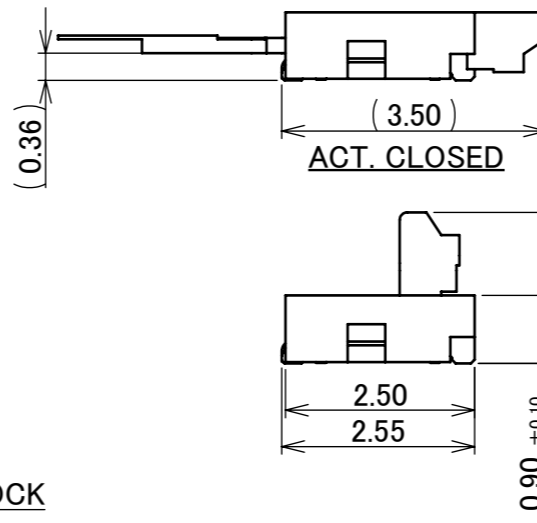
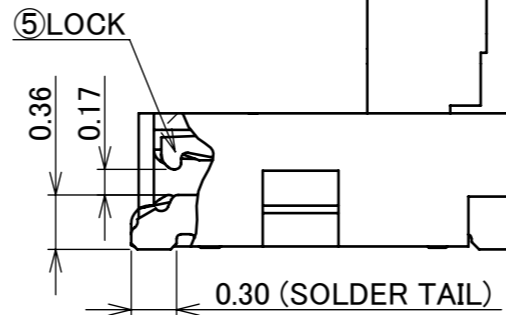
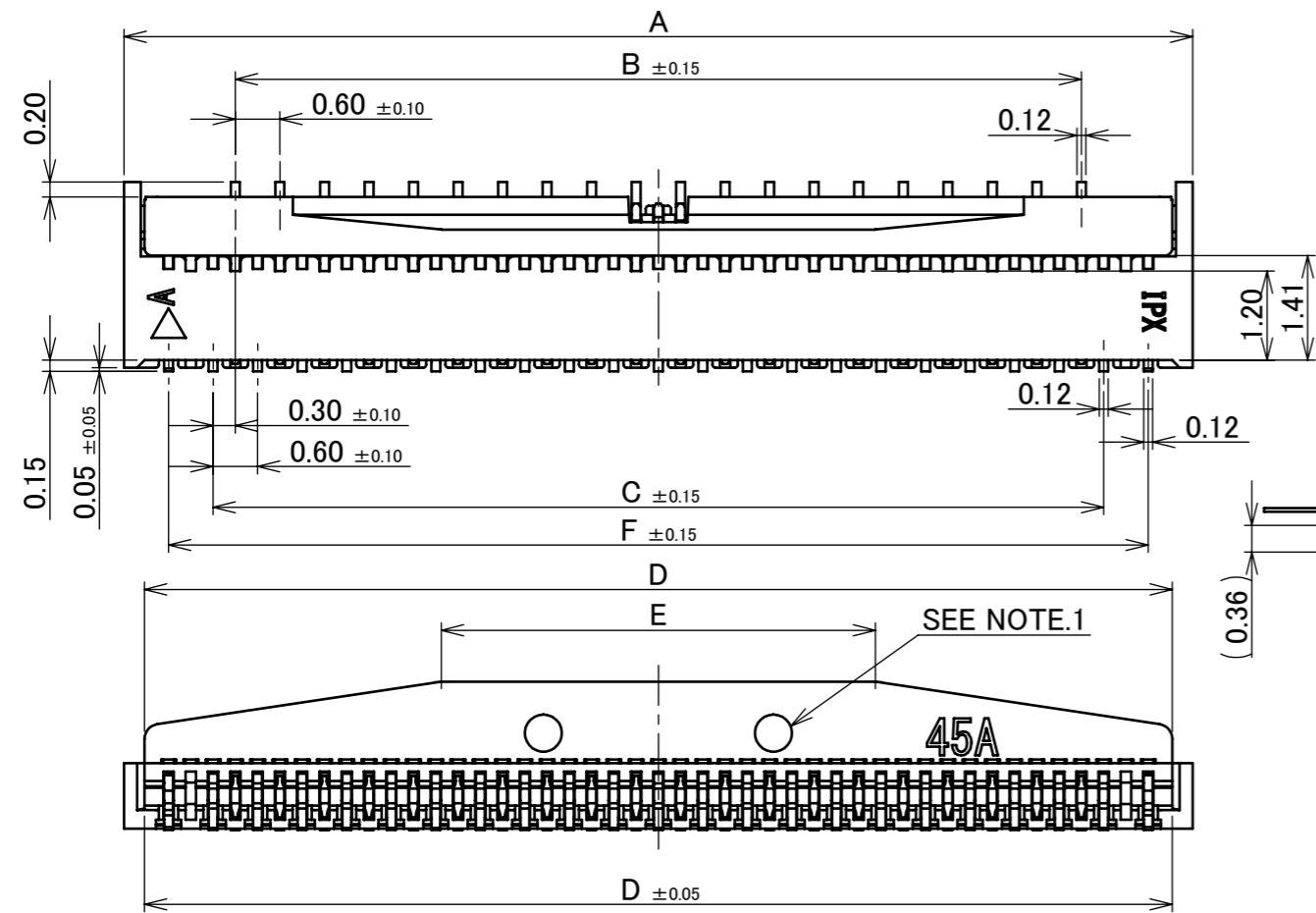

PART NO.	Pos.	A	B	C	D	E	F
◆ 20584-029E-01	29P	10.80	7.80	8.40	10.25	6.25	9.60
◆ 20584-031E-01	31P	11.40	8.40	9.00	10.85	6.85	10.20
◆ 20584-035E-01	35P	12.60	9.60	10.20	12.05	8.05	11.40
◆ 20584-037E-01	37P	13.20	10.20	10.80	12.65	4.65	12.00
◆ 20584-039E-01	39P	13.80	10.80	11.40	13.25	5.25	12.60
◆ 20584-041E-01	41P	14.40	11.40	12.00	13.85	5.85	13.20
◆ 20584-045E-01	45P	15.60	12.60	13.20	15.05	7.05	14.40
◆ 20584-047E-01	47P	16.20	13.20	13.80	15.65	7.65	15.00
20584-051E-01	51P	17.40	14.40	15.00	16.85	8.85	16.20
20584-053E-01	53P	18.00	15.00	15.60	17.45	9.45	16.80
20584-057E-01	57P	19.20	16.20	16.80	18.65	10.65	18.00
20584-061E-01	61P	20.40	17.40	18.00	19.85	11.85	19.20
◆ 20584-063E-01	63P	21.00	18.00	18.60	20.45	8.45	19.80
20584-071E-01	71P	23.40	20.40	21.00	22.85	10.85	22.20

◆ MARK MEANS NOT AVAILABLE.

NOTES.

1. THIS DENT SHAPE IS PURPOSED FOR GOOD INJECTION QUALITY. THIS DENT SHAPE WILL NOT AFFECT CONNECTR FUNCTION. DENT SHAPE SHOWN ON DRAWING IS JUST FOR REFERENCE. DENT SHAPE AND QUANTITY MIGHT CHABGE FROM DIFFERENT PIN COUNT AND DIFFERENT TOOLING.
2. CONTACT POINT : TOP AND BOTTOM CONTACT

CAUTION VISIT OUR WEBSITE FOR LATEST VERSIONS OF INSTRUCTION MANUAL NO. HIM-12007 TO HANDLE THE PRODUCT PROPERLY AND SAFELY.

TABLE 1

PART NO.	FINISH		
20584-0**E-01	CONTACT AREA : Au 0.10 μm MIN. OVER Ni 1.00 μm MIN. SOLDERING AREA : Au 0.03 μm MIN. OVER Ni 1.00 μm MIN.		
5	LOCK	PHOSPHOR BRONZE SOLDERING AREA : Au 0.03 μm MIN. OVER Ni 1.00 μm MIN.	
4	CONTACT (B)	PHOSPHOR BRONZE SEE TABLE 1, WITH Ni STRIPE	
3	CONTACT (A)	PHOSPHOR BRONZE SEE TABLE 1	
2	ACTUATOR	LCP UL94V-0, BEIGE	
1	HOUSNIG	LCP UL94V-0, BEIGE	
NO.	DISCRIPTION	MATERIAL	FINISH , REMARKS

17	Z200896	M.M	Aug./31/'20	Y.S	ANGLE	±2°	6 OVER 30 MAX.	±0.3	PROJECTION	SERIES No. R3	CUSTOMER COPY	
16	Z200568	M.M	June/05/'20	Y.S	6 MAX.	±0.2	30 OVER 120 MAX.	±0.5				
15	Z191376	M.M	Oct./15/'19	H.I	GENERAL TOLERANCE.			TITLE MINIFLEX® 3-BFN LONG ACTUATOR LK TYPE	SCALE	I-PEX		
14	Z190885	M.M	July/04/'19	H.I	DWG.	DATE 2013/03/01			10:1			
13	Z181440	T.O	Nov./02/'18	H.I	CHK. J.Tateishi			UNIT	mm			
12	Z181286	T.O	Oct./01/'18	H.I		APP.				SIZE		
REV.	ECN	BY	DATE	APP.	E.Kawabe		DWG. No.	20584	SHEET	1/7	REV.	17

# EVEN NUMBER POS.

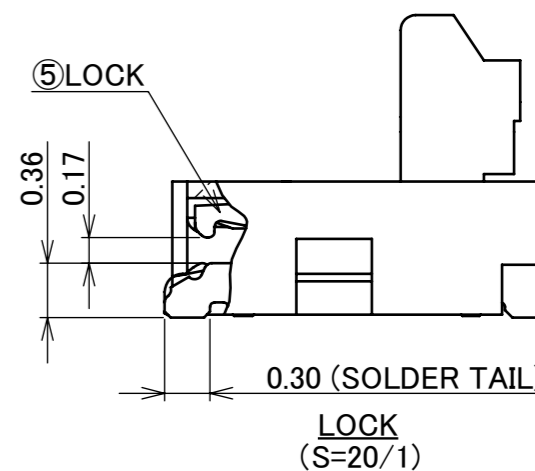
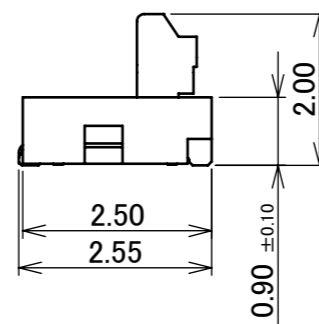
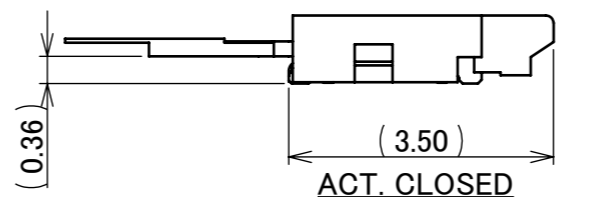
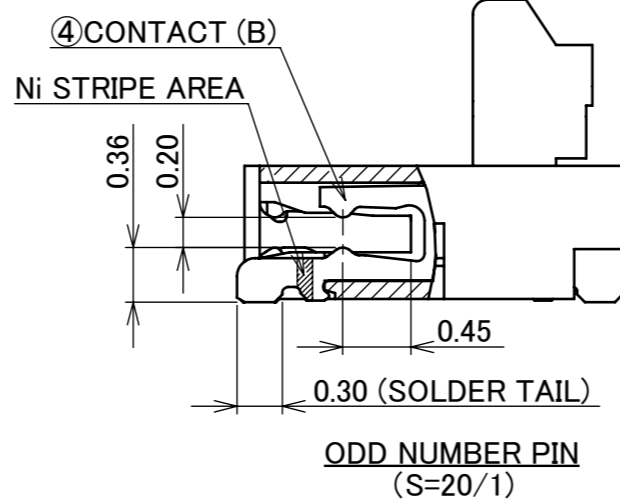
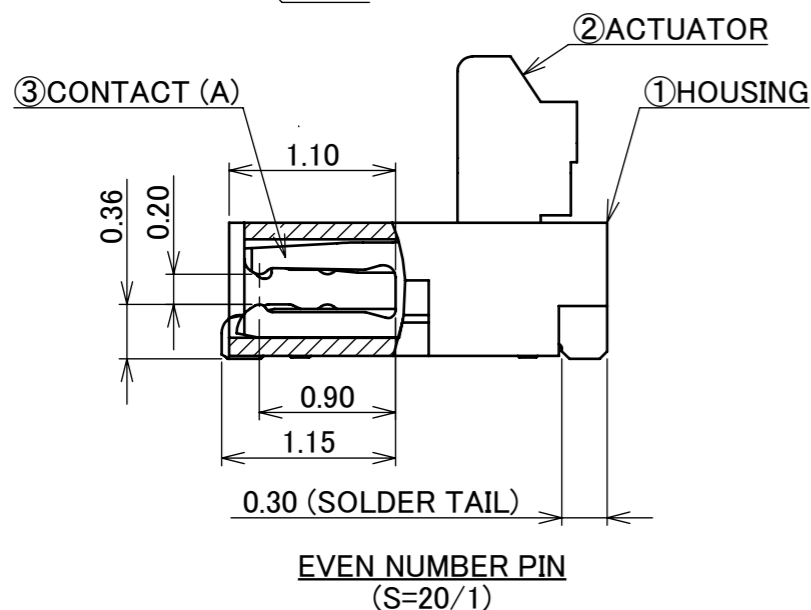
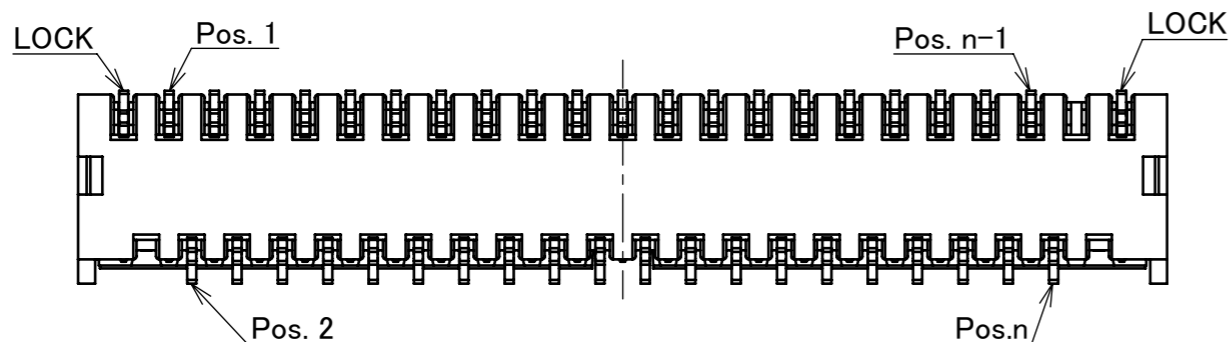
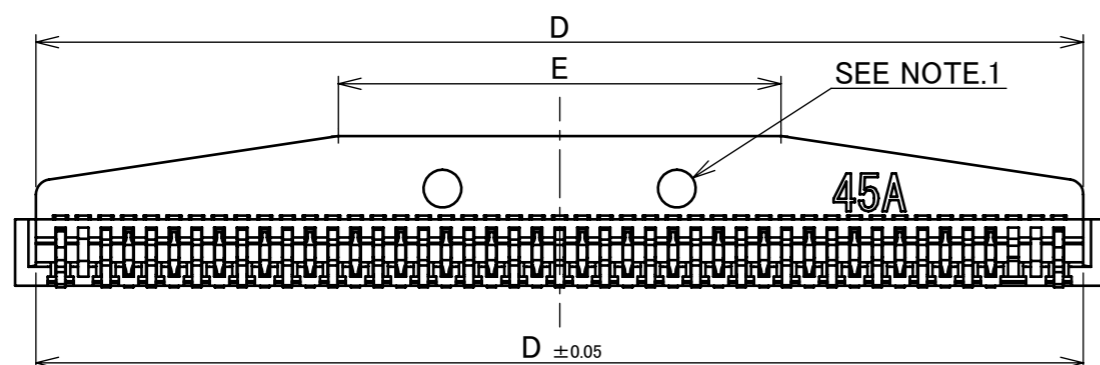
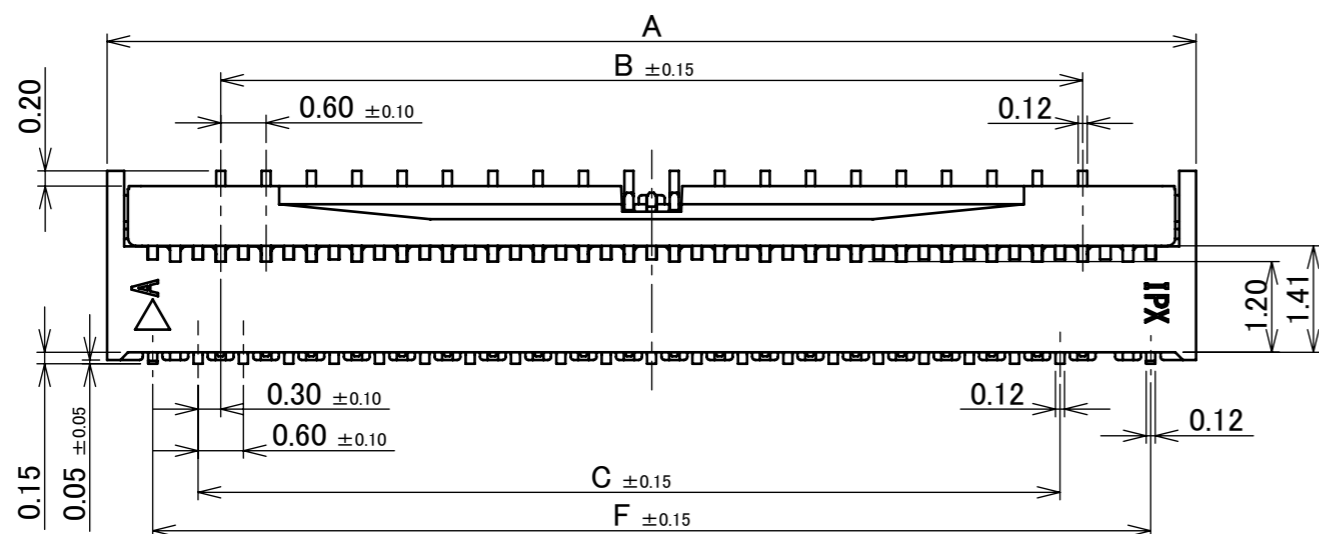

PART NO.	Pos.	A	B	C	D	E	F
◆ 20584-030E-01	30P	11.40	8.40	8.40	10.85	6.85	10.20
◆ 20584-034E-01	34P	12.60	9.60	9.60	12.05	8.05	11.40
◆ 20584-038E-01	38P	13.80	10.80	10.80	13.25	5.25	12.60
◆ 20584-040E-01	40P	14.40	11.40	11.40	13.85	5.85	13.20
◆ 20584-050E-01	50P	17.40	14.40	14.40	16.85	8.85	16.20
◆ 20584-056E-01	56P	19.20	16.20	16.20	18.65	10.65	18.00

◆ MARK MEANS NOT AVAILABLE.

ANGLE	±2°	6 OVER 30 MAX.	±0.3	PROJECTION ⊕	SERIES No. R3	CUSTOMER COPY	
	6 MAX.	±0.2	30 OVER 120 MAX.				
GENERAL TOLERANCE.				TITLE		SCALE	<b>I-PEX</b>
DWG.	DATE			MINIFLEX® 3-BFN LONG ACTUATOR LK TYPE		10:1	
CHK.						UNIT	
APP.				DWG. No.	20584	SIZE	SHEET
						A3	2/7
							REV.
							17

ITEMS	SPECIFICATION
RATING VOLTAGE	50V AC (PER CONTACT)
RATING AMPERAGE	0.3A DC (PER CONTACT)
OPERATING TEMPERATURE	233~358K (-40°C~+85°C)
OPERATING HUMIDITY	20~80%RH (NON-CONDENSING)
CONTACT RESISTANCE	INITIAL : 60mohm MAX. / AFTER TEST : $\triangleleft$ 40mohm MAX.
INSULATION RESISTANCE	100Mohm MIN.
DIELECTRIC WITHSTANDING VOLTAGE	AC250V 1min
DURABILITY	20 CYCLES
ACTUATOR LOCKING FORCE (INITIAL / 20 CYCLES)	INITIAL / 20 CYCLES 0.21N (21gf) $\times$ (n + 2) MAX.
ACTUATOR UNLOCKING FORCE (INITIAL / 20 CYCLES)	INITIAL / 20 CYCLES 0.014N (1.4gf) $\times$ (n + 2) MIN.
FPC RETENTION FORCE (INITIAL / AFTER TEST)	INITIAL: 0.13N (13gf) $\times$ n + 1.0N MIN. / AFTER TEST: 0.10N (10gf) $\times$ n + 1.0N MIN.
COPLANARITY	0.10 MAX.
PRODUCT SPECIFICATION	PRS-1789
TEST REPORT	TR-13022
PACKING STANDARD	PST-13013
INSTRUCTION MANUAL	HIM-12007
APPEARANCE CRITERIA No.	QLS-A***

※ "n" IS THE NUMBER OF PIN

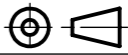
ANGLE	$\pm 2^\circ$	6 OVER 30 MAX.	$\pm 0.3$	PROJECTION 	SERIES No. R3	CUSTOMER COPY		
6 MAX.	$\pm 0.2$	30 OVER 120 MAX.	$\pm 0.5$					
GENERAL TOLERANCE.				TITLE MINIFLEX <sup>®</sup> 3-BFN LONG ACTUATOR LK TYPE	SCALE	<b>I-PEX</b>		
DWG.	DATE							
CHK.								
APP.								
				DWG. No.	20584	SIZE A3	SHEET 3/7	REV. 17

# ODD NUMBER POS.

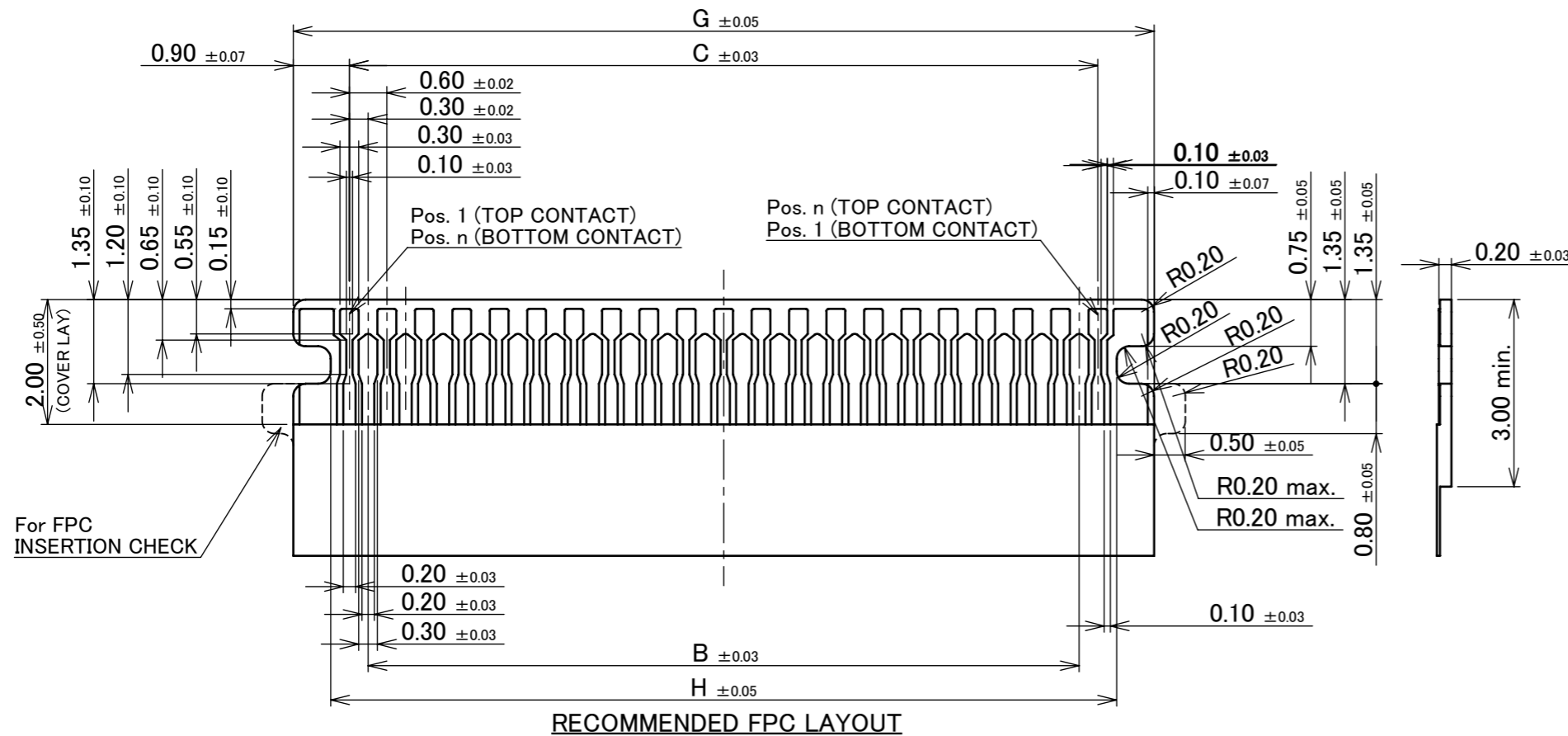

RECOMMENDED FPC LAYOUT

PART NO.	Pos.	B	C	F	G	H
◆ 20584-029E-01	29P	7.80	8.40	9.60	10.20	9.00
◆ 20584-031E-01	31P	8.40	9.00	10.20	10.80	9.60
◆ 20584-035E-01	35P	9.60	10.20	11.40	12.00	10.80
◆ 20584-037E-01	37P	10.20	10.80	12.00	12.60	11.40
◆ 20584-039E-01	39P	10.80	11.40	12.60	13.20	12.00
◆ 20584-041E-01	41P	11.40	12.00	13.20	13.80	12.60
◆ 20584-045E-01	45P	12.60	13.20	14.40	15.00	13.80
◆ 20584-047E-01	47P	13.20	13.80	15.00	15.60	14.40
20584-051E-01	51P	14.40	15.00	16.20	16.80	15.60
20584-053E-01	53P	15.00	15.60	16.80	17.40	16.20
20584-057E-01	57P	16.20	16.80	18.00	18.60	17.40
20584-061E-01	61P	17.40	18.00	19.20	19.80	18.60
◆ 20584-063E-01	63P	18.00	18.60	19.80	20.40	19.20
20584-071E-01	71P	20.40	21.00	22.20	22.80	21.60

◆ MARK MEANS NOT AVAILABLE.

NOTES

3. MATERIAL  
COVER FILM : PI  
CONDUCTOR : COPPER(RARE)  
BASE FILM : PI  
STIFFENER : PI  
ADHESIVE : THERMOSETTING ADHESIVE
4. FINISH  
Au OVER Ni UNDER PLATING.
5. SOLDER RESIST SHALL BE APPLIED TO PREVENT SHORT CIRCUITS WHEN PLACING SIGNAL LINES ON GROUND AREA.

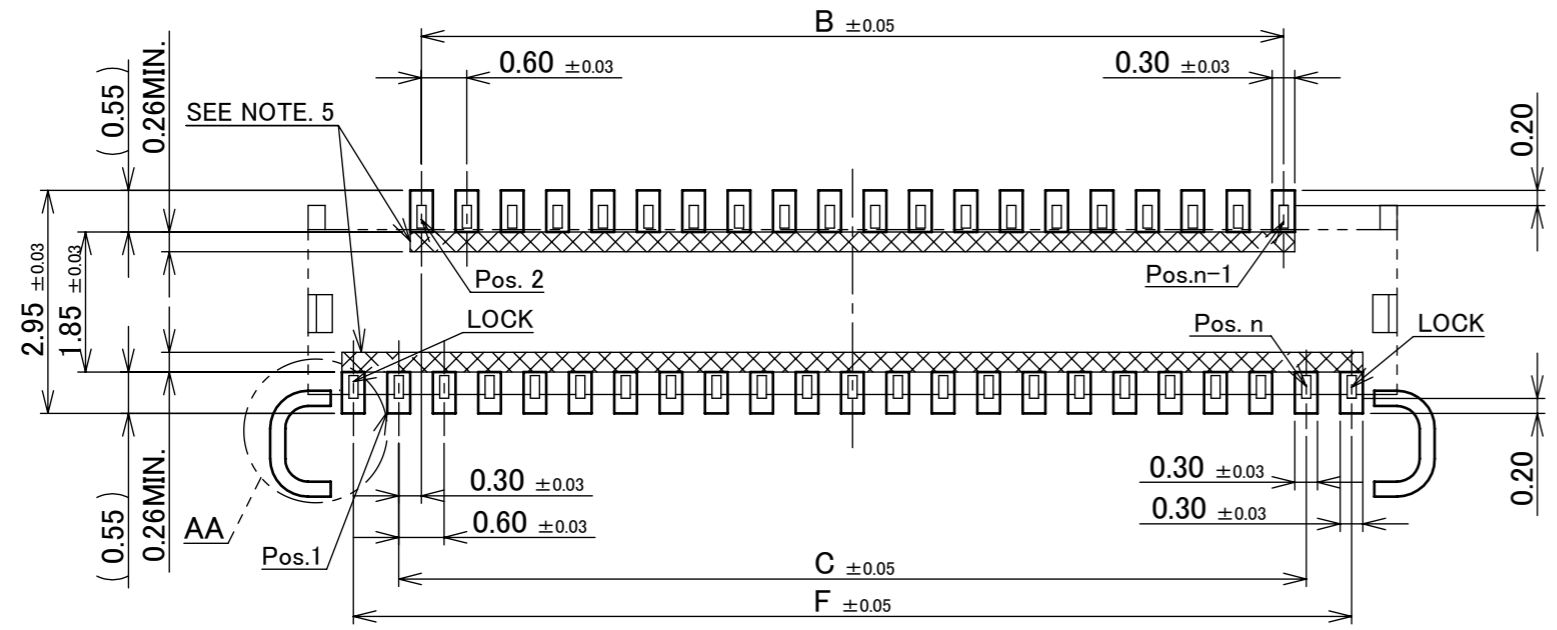

RECOMMENDED PCB LAYOUT & METAL MASK LAYOUT  
METAL MASK THICKNESS : t=0.12mm

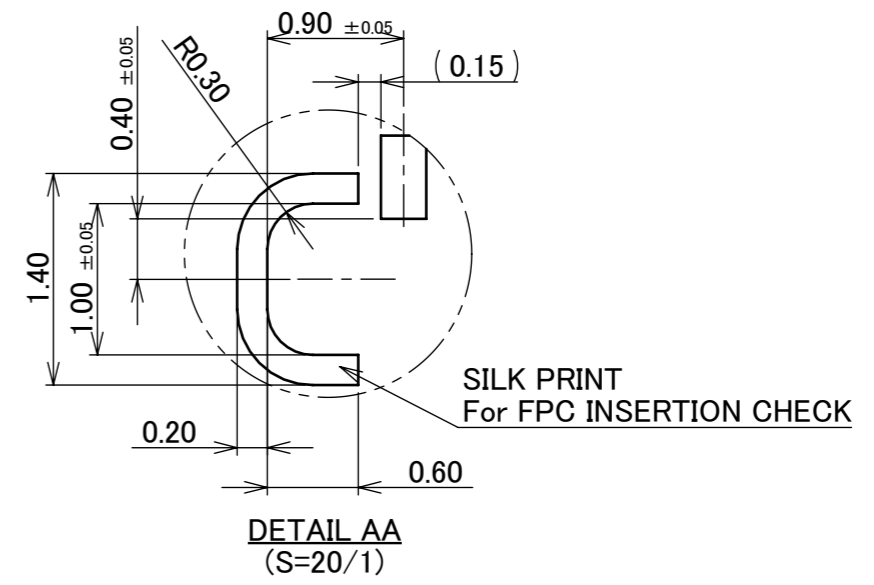

DETAIL AA  
(S=20/1)

ANGLE	±2°	6 OVER 30 MAX.	±0.3	PROJECTION	SERIES No.	CUSTOMER COPY	
	6 MAX.	±0.2	30 OVER 120 MAX.	±0.5	R3		
GENERAL TOLERANCE.				TITLE	SCALE	I-PEX	
DWG.	DATE			MINIFLEX® 3-BFN LONG ACTUATOR LK TYPE	10:1		
CHK.				DWG. No.	UNIT		
APP.				20584	mm		
				SIZE	SHEET	REV.	
				A3	4/7	17	

# EVEN NUMBER POS.

PART NO.	Pos.	B	C	F	G	H
◆ 20584-030E-01	30P	8.40	8.40	10.20	10.80	9.60
◆ 20584-034E-01	34P	9.60	9.60	11.40	12.00	10.80
◆ 20584-038E-01	38P	10.80	10.80	12.60	13.20	12.00
◆ 20584-040E-01	40P	11.40	11.40	13.20	13.80	12.60
◆ 20584-050E-01	50P	14.40	14.40	16.20	16.80	15.60
◆ 20584-056E-01	56P	16.20	16.20	18.00	18.60	17.40

◆ MARK MEANS NOT AVAILABLE.

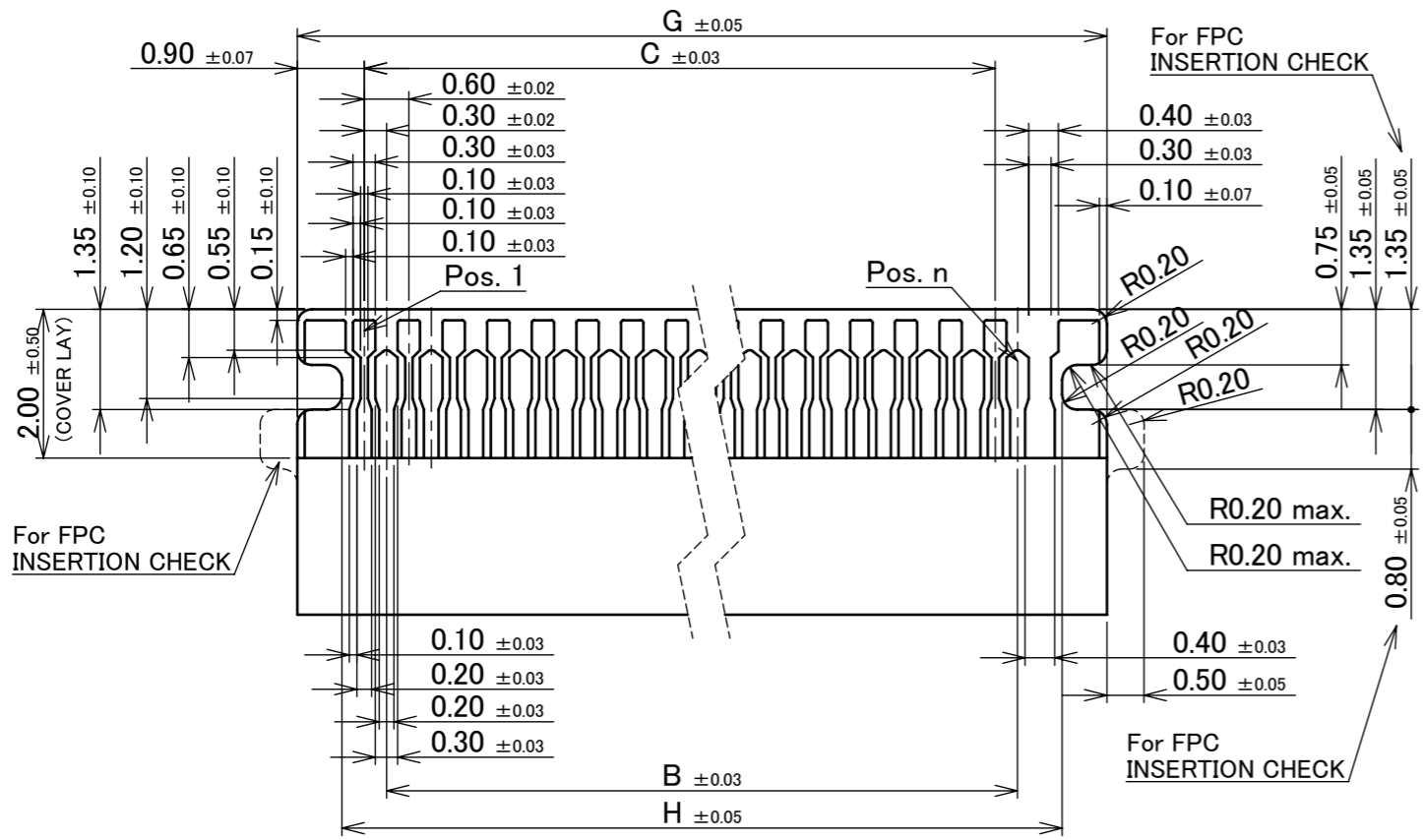

RECOMMENDED FPC LAYOUT (FOR TOP CONTACT)

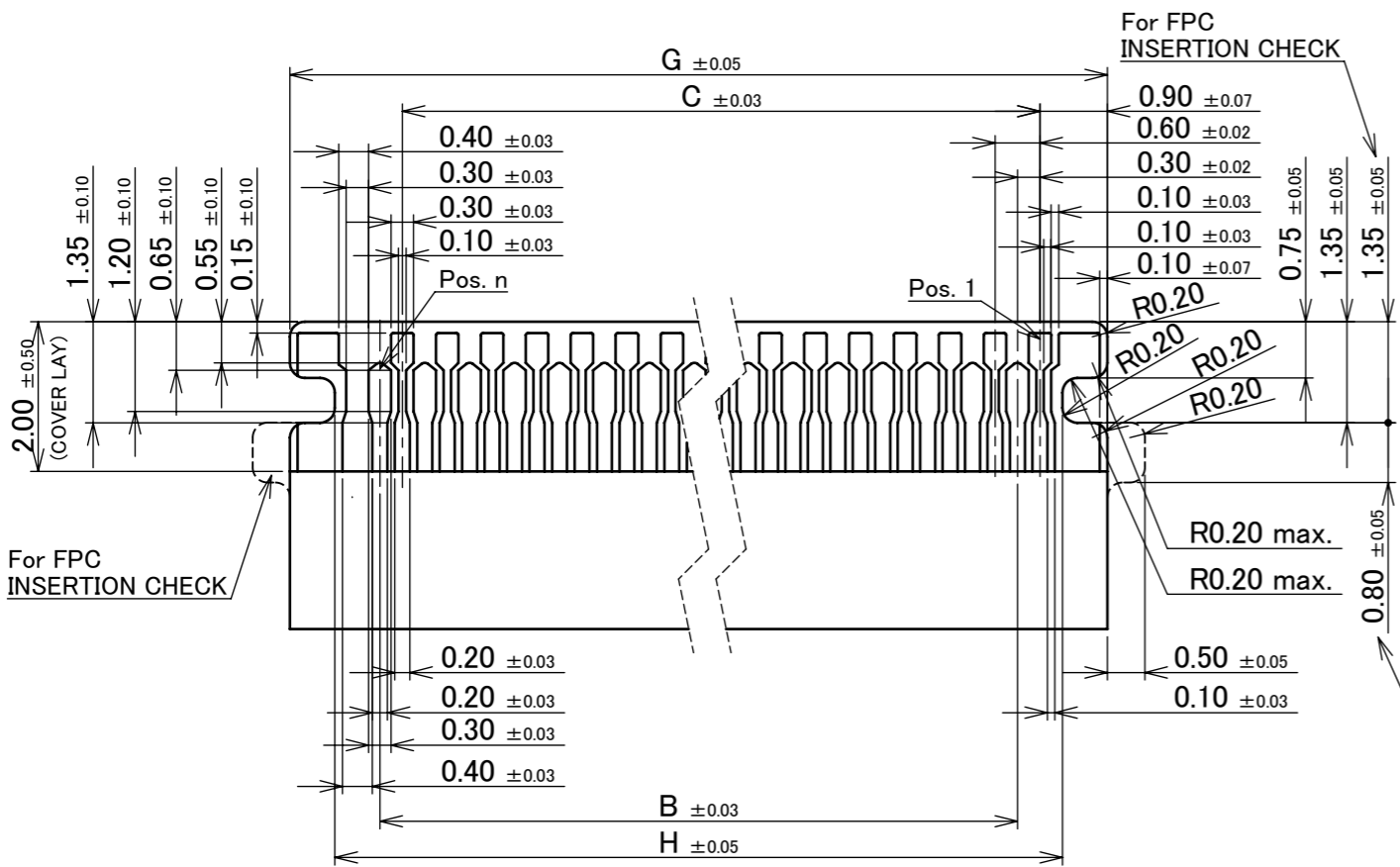
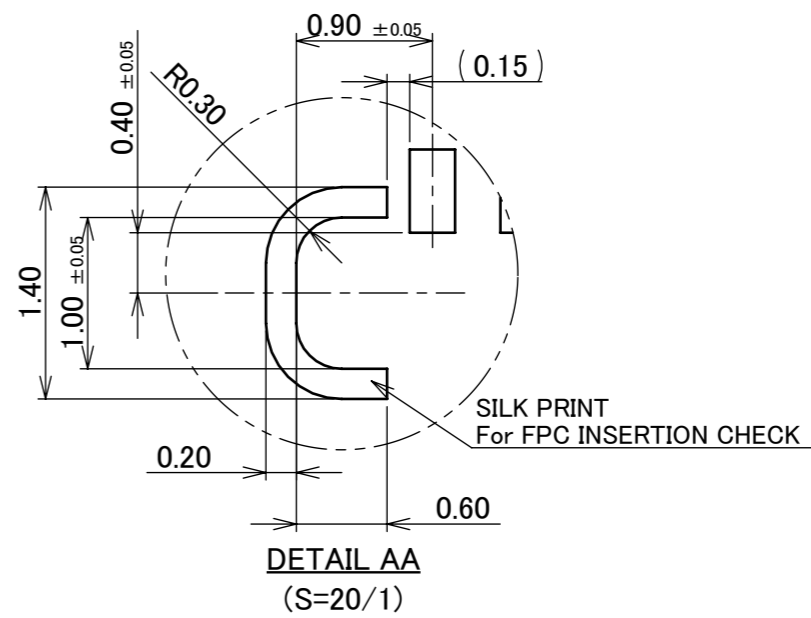
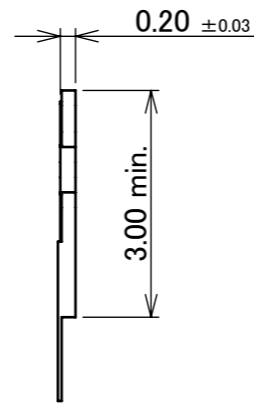

RECOMMENDED FPC LAYOUT (FOR BOTTOM CONTACT)

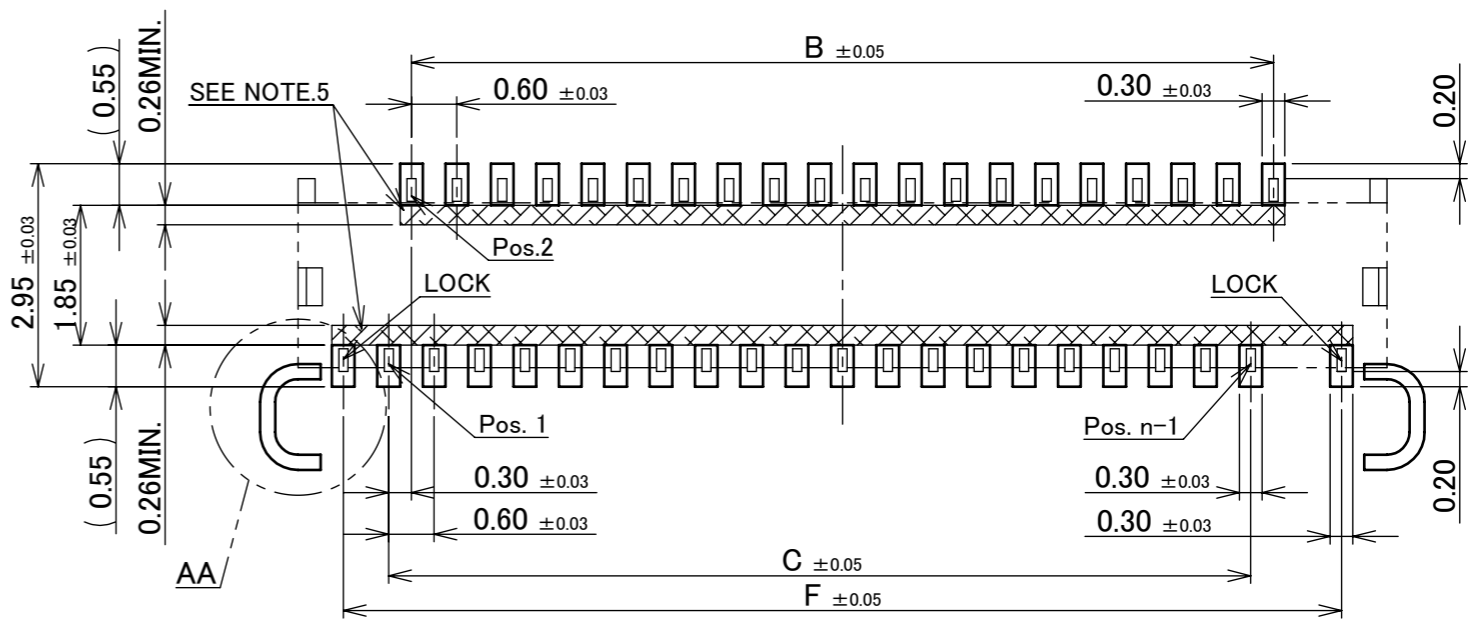

RECOMMENDED PCB LAYOUT & METAL MASK LAYOUT  
METAL MASK THICKNESS : t=0.12mm

ANGLE	±2°	6 OVER 30 MAX.	±0.3	PROJECTION	SERIES No.	CUSTOMER COPY	
6 MAX.	±0.2	30 OVER 120 MAX.	±0.5	⊕	R3		
GENERAL TOLERANCE.				TITLE	SCALE	I-PEX	
DWG.	DATE			MINIFLEX® 3-BFN LONG ACTUATOR LK TYPE	10:1		
CHK.					UNIT		
APP.					mm		
				DWG. No.	SIZE	SHEET	REV.
				20584	A3	5/7	17

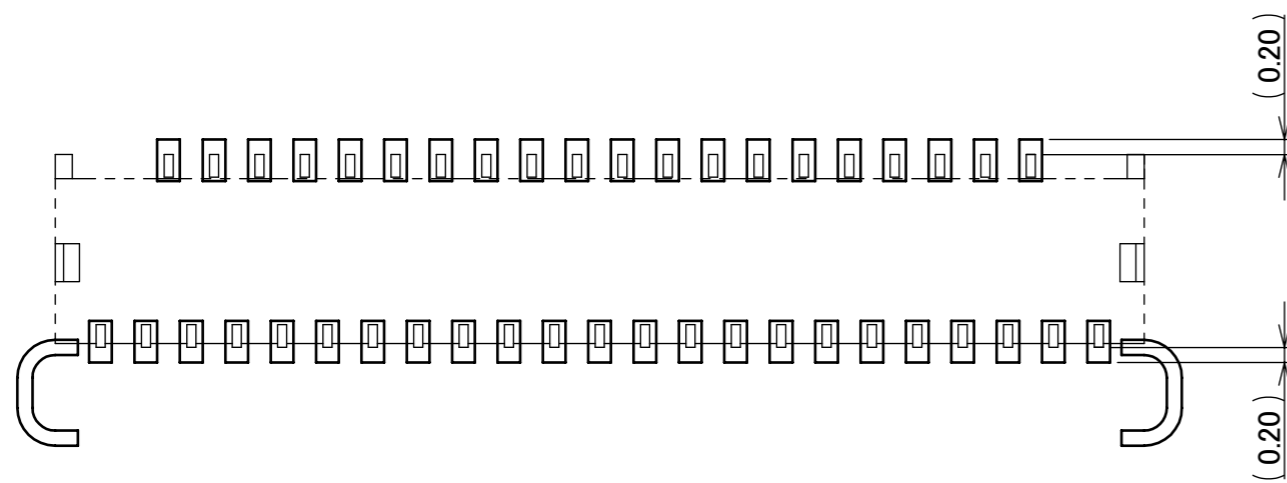

CONNECTOR ON RECOMMENDED PCB LAYOUT

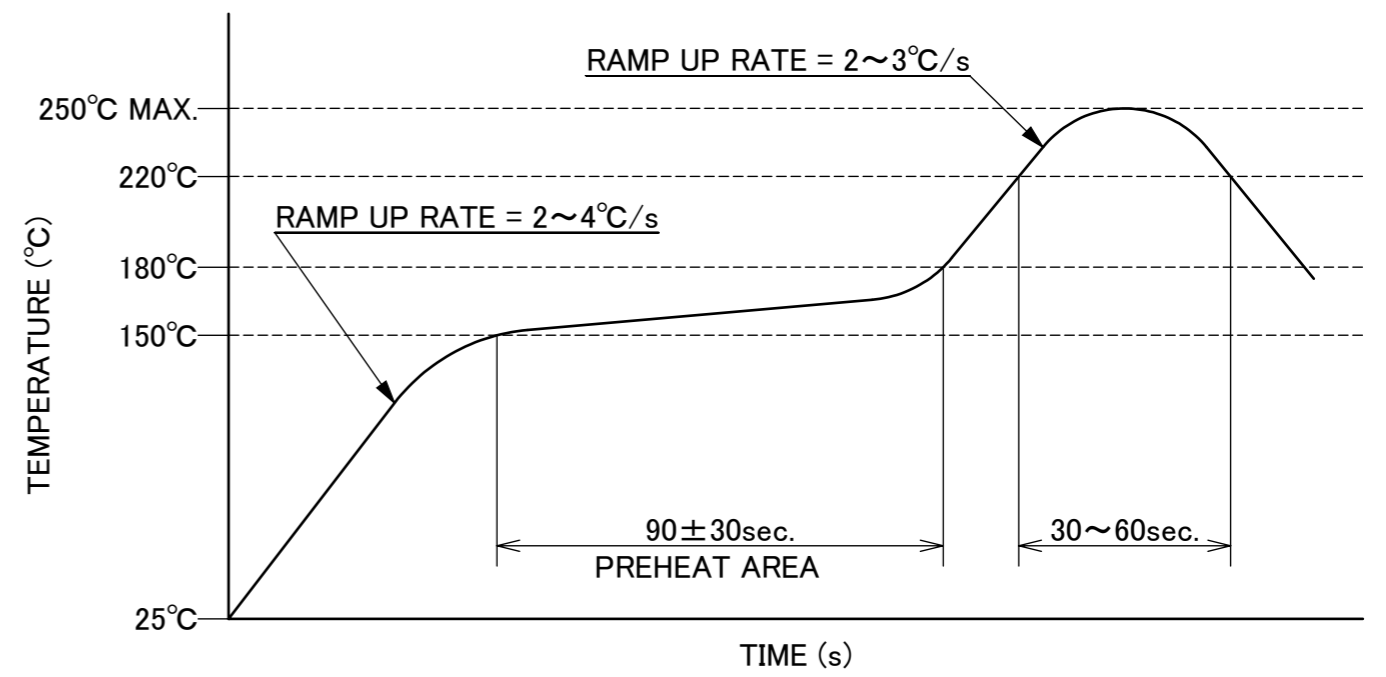

REFLOW TEMPERATURE PROFILE  
 SENJU METAL INDUSTRY CO., LTD. : M705-SHF(Sn96.5 Ag3.0 Cu0.5)

ANGLE	±2°	6 OVER 30 MAX.	±0.3	PROJECTION 	SERIES No. R3	CUSTOMER COPY		
6 MAX.	±0.2	30 OVER 120 MAX.	±0.5					
GENERAL TOLERANCE.				TITLE MINIFLEX® 3-BFN LONG ACTUATOR LK TYPE	SCALE 10:1			
DWG.	DATE							
CHK.								
APP.								
				DWG. No.	20584	SIZE	SHEET	REV.
						A3	6/7	17

DEVICE P/N	J	K	L	M	N	P	QTY. PER EMBOSS REEL (PIECES / REEL)	QTY. PER PACKING CARTON (REELS / CARTON)
◆ 20584-029E-01	24.0	21.5	11.50	11.20	6.00	-	4,000 / REEL	5 / CARTON = 20,000
◆ 20584-030E-01				11.80				
◆ 20584-031E-01				13.00				
◆ 20584-035E-01				13.60				
◆ 20584-037E-01				15.40				
◆ 20584-040E-01				16.00				
◆ 20584-041E-01				16.60				
◆ 20584-045E-01				17.80				
◆ 20584-047E-01	32.0	26.0	14.20	18.40	10.00	28.40	4,000 / REEL	4 / CARTON = 16,000
◆ 20584-050E-01				19.60				
◆ 20584-051E-01				20.80				
◆ 20584-053E-01				22.60				
◆ 20584-057E-01	44.0	37.0	20.20	22.60	-	40.40	4,000 / REEL	3 / CARTON = 12,000
◆ 20584-061E-01				22.60				
◆ 20584-071E-01								

◆ MARK MEANS NOT AVAILABLE.

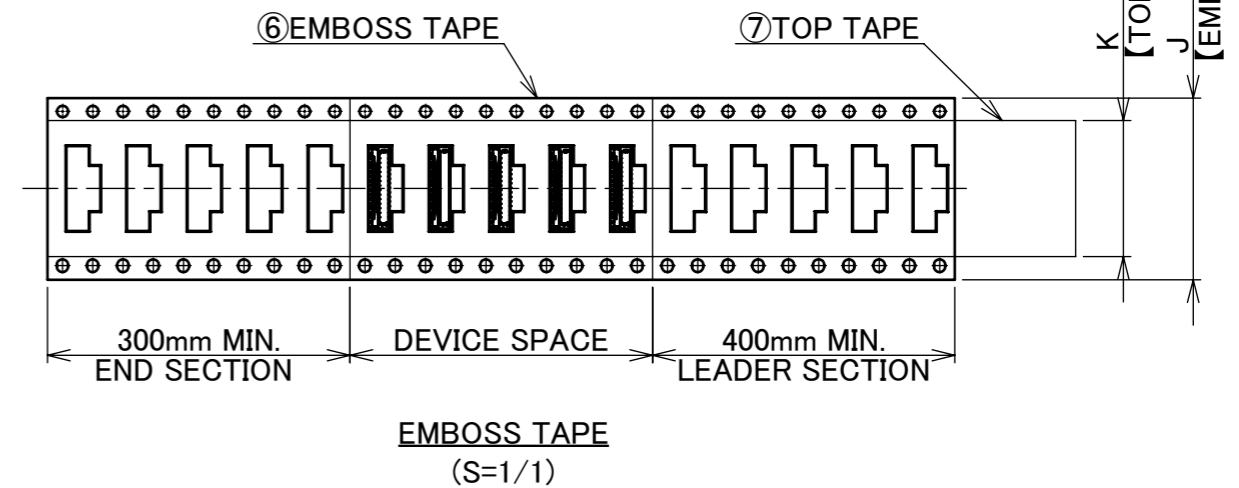
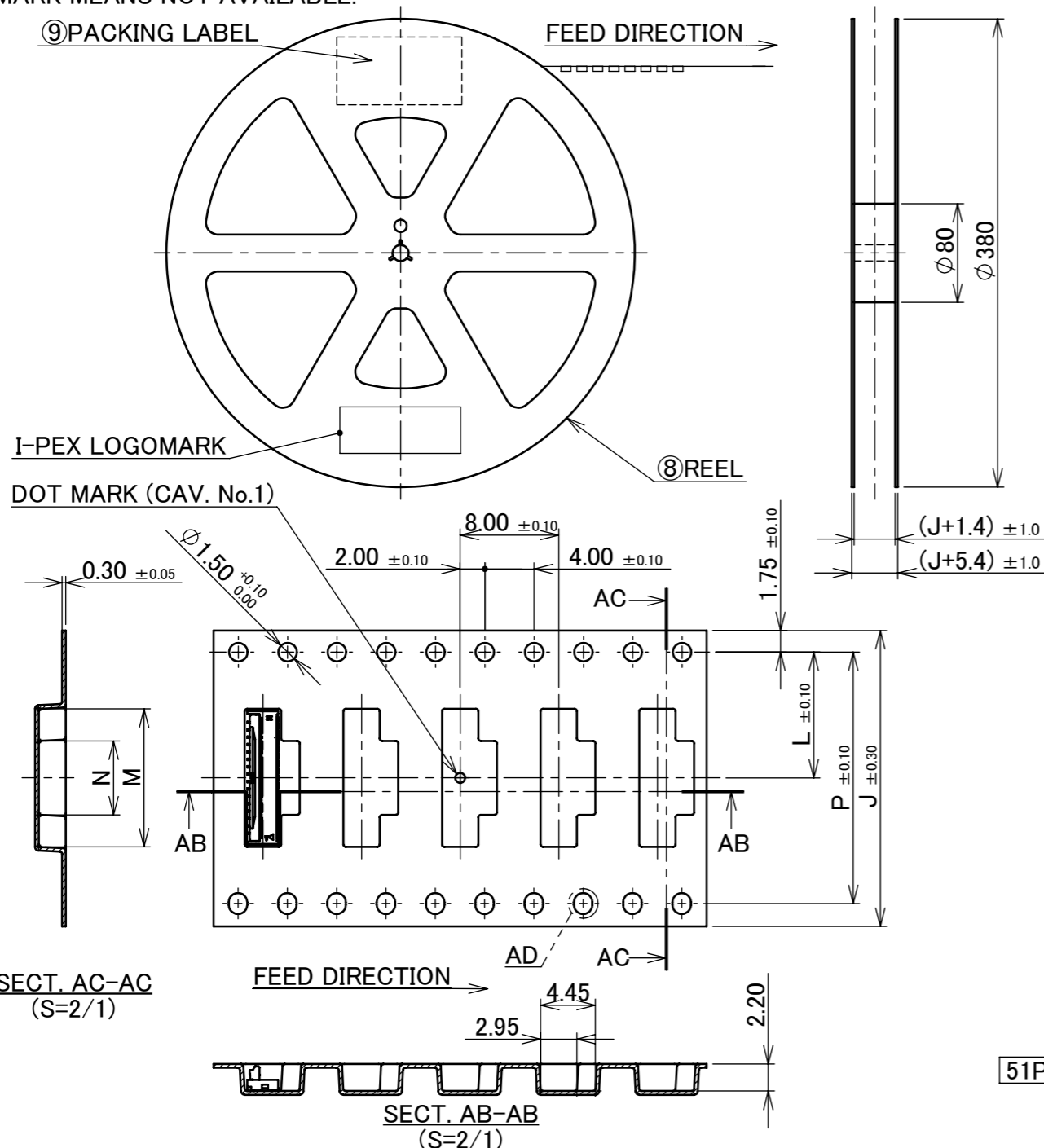

NOTES.

- TAPING SPECIFICATION FOLLOWS JIS C 0806 (IEC 60286-3).
- MAKE EMPTY SECTION OF LEADER AND END ON EACH END OF THE TAPE.
- TOP TAPE SHALL NOT STICK OUT FROM EMBOSS TAPE.
- TOP TAPE SHALL NOT COVER FEED HOLE.

NO.	DISCRIPTION	MATERIAL	FINISH , REMARKS
9	PACKING LABEL	-	-
8	REEL	PS	BLACK
7	TOP TAPE	PET t=0.062 TRANSPARENCY	ANTI-STATIC TYPE HEAT WELDING TYPE
6	EMBOSS TAPE	PS t=0.3 TRANSPARENCY	ANTI-STATIC TYPE

ANGLE	±2°	6 OVER 30 MAX.	±0.3	PROJECTION	SERIES No.	CUSTOMER COPY
6 MAX.	±0.2	30 OVER 120 MAX.	±0.5		R3	
GENERAL TOLERANCE.				TITLE	SCALE	
DWG.	DATE	MINIFLEX® 3-BFN LONG ACTUATOR LK TYPE		1:X		<b>I-PEX</b>
CHK.				UNIT		
APP.		DWG. No. 20584		mm		
				SIZE	SHEET	REV.
				A3	7/7	17

51P, 53P, 57P, 61P, 71P ONLY

单击下面可查看定价，库存，交付和生命周期等信息

[>>I-PEX](#)