

CABLINE® - VS

VESA标准款连接器, 适用于高速数据传输(20+ Gbps/lane), 机械锁扣, 0.5 mm 间距, 水平对插款的极细同轴线连接器

Product Specifications:

Mating type		Horizontal
Board Pitch (mm)		0.5
Wiping Length (mm)		0.61
Mated size (mm)	Height	1.0 +/- 0.1
	Width	Formula: 7.55 + (0.5*?p)
	Depth	5.8
Pin Counts	Range	Up to 50
	Available	20, 30, 40, 50

Applicable Cable Size:

Maximum O.D. (mm)	0.5
Micro-Coaxial for Signal (AWG)	45 ohm: #36 or smaller 50 ohm: #38 or smaller
Twin Coaxial (AWG)	#40
Discrete (AWG)	#32 or smaller

Applicable Standards (Reference Only):

Thunderbolt 3 (20 Gbps/lane), PCIe Gen 4 (16 GT/s), USB 3.1 Gen 2 (10 Gbps), eDP HBR 3 (8.1 Gbps)

*如您需要了解未列出或不在范围内的Pin数, 请咨询我们。

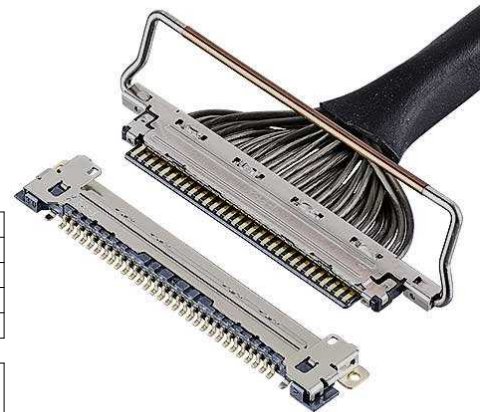

▶ 电子设备内部的高速率传输的理想之选USB4 / Thunderbolt 3 (20+ Gbps/lane)

Thunderbolt 3 (20 Gbps/lane)

眼图 (微分)

比特率: 20 Gbps

上升时间: 30ps (10-90%)

输入电压: 800mVp-p

*更多测试细节, 请联系I-PEX 连接器。

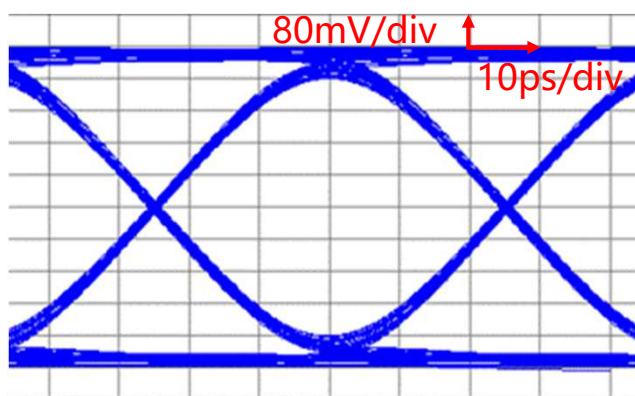

▶ 机械锁扣防止连接器不完全嵌合/未嵌合及脱落

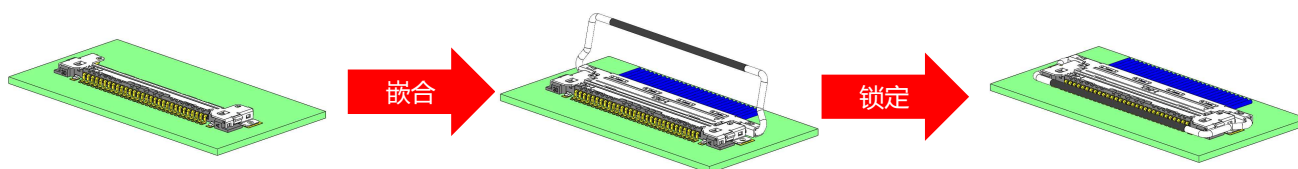

干涉

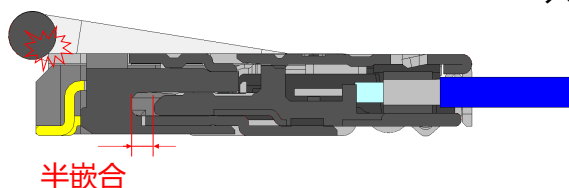

只有当公座完全和母座嵌合时, 机械锁扣才能锁上

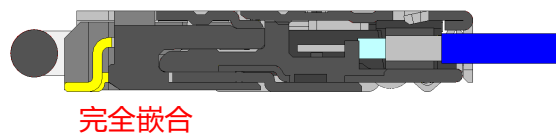

▶ I-PEX VS系列多款连接器可选

I-PEX VS 系列 (0.5 mm 间距, 水平对插方式)

CABLINE-VS, VS II 的母座和 EVAFLEX® 5-VS 可以安装在相同布局的PCB上。

CABLINE-VS 母座:

VESA 标准连接器, Notebook PC panel 连接器占较大市场份额。

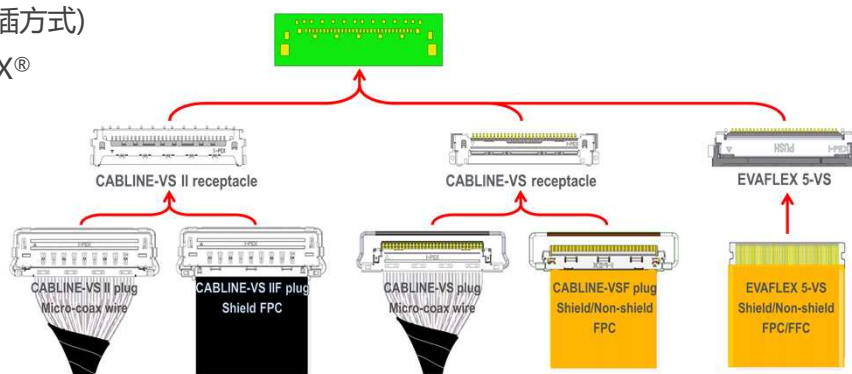

Component Parts Details

Component Parts

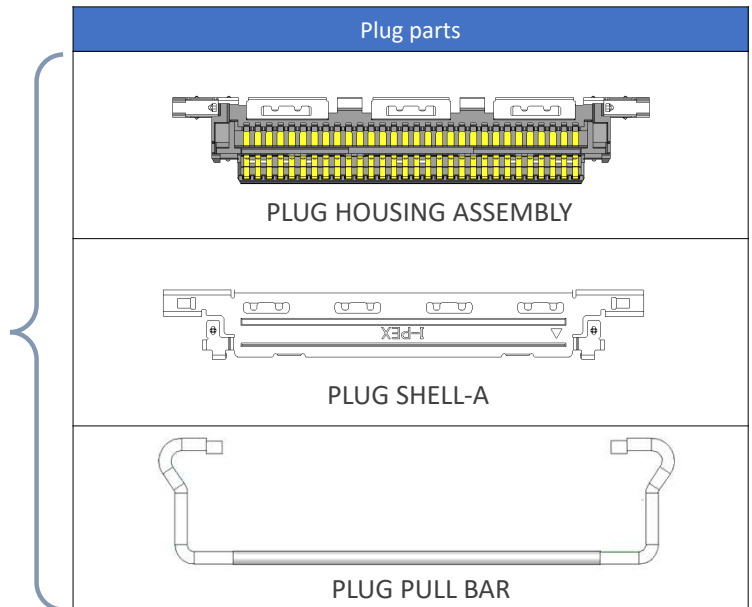
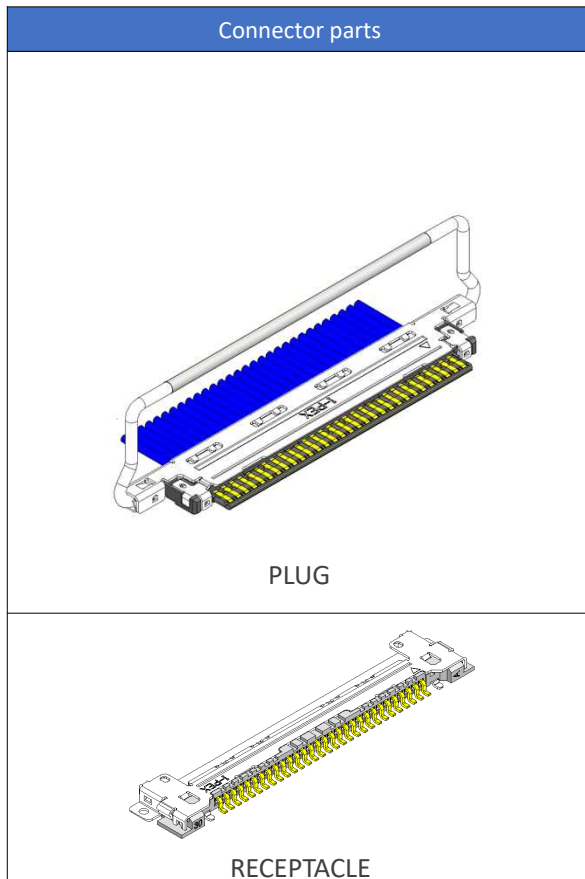

Plug for Cable Assembly

Recommended P/N 20453-2**T-03(20P/30P/40P) 20453-250T-03S(50P)

PART NO.	Pos.	A	B	C	D	E	F	G	H
20453-#20T-#1	20	9.50	10.30	12.56	16.00	16.15	13.00	17.55	14.45
20453-#30T-#1	30	14.50	15.30	17.56	21.00	21.15	18.00	22.55	19.45
20453-#40T-#1	40	19.50	20.30	22.56	26.00	26.15	23.00	27.55	24.45
20453-#50T-#1S	50	24.50	25.30	27.56	31.00	31.15	28.00	32.55	29.45

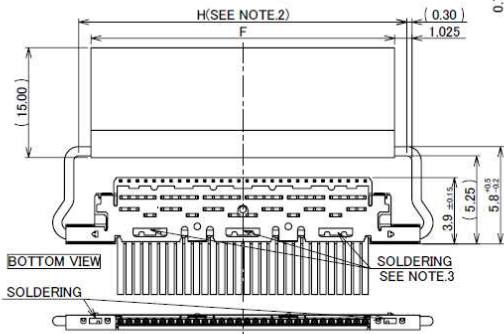
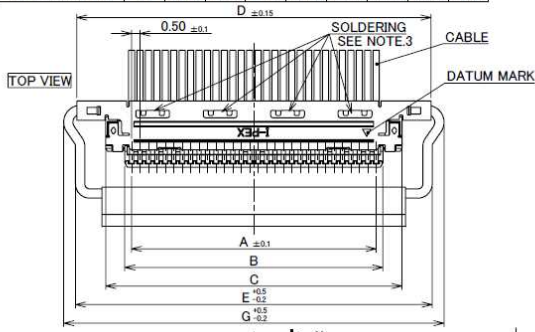

NOTES.
 1.RECOMMENDED PULL-TAPE
 PULL-TAPE : TERAOKA'S INSULATION TAPE No.650S(#50) t=0.08
 2.PULL-TAPE CAN BE PUT WITHIN THE RANGE OF "H"(STRAIGHT ARFA)
 3.SOLDERING IS ONLY A CASE WITH GND-BAR

WITH PULL-BAR & PULL-TAPE

P/N:20453-#**T-#**#
 NOTHING : HOUSING ASSY P/N 20454-0**T
 S : HOUSING ASSY P/N 20454-0**T-01
 1 : WITH PULL-BAR P/N 2576-0**#*
 2 : WITHOUT PULL-BAR
 3 : WITH INSULATION COAT PULL-BAR P/N 2576-1**#*
 0 : WITH DATUM MARK P/N 2574-0**#
 1 : WITHOUT DATUM MARK P/N 2574-1**#

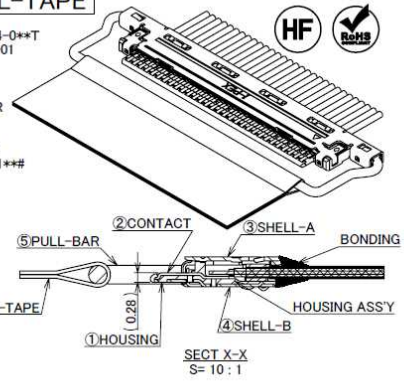
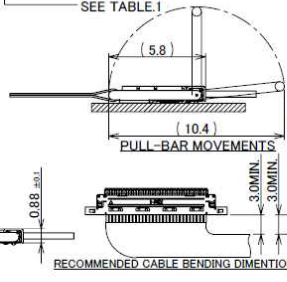

PART NO.	CABLE ASSY PART NO.	HOUSING ASSY PART NO.	SHELL-A PART NO.	PULL-BAR PART NO.
	20453-0**T-#1*	20454-0**T-**	2574-***	2576-0**#*#
	20453-2**T-#1*	20454-2**T-**	2574-***2	2576-0**#*#

TABLE 1

PART NO.	CONTACT FINISH	SHELL-A FINISH	SHELL-B FINISH
20453-0**T-***	CONTACT AREA : Au 0.1 μm MIN. OVER Ni 1.00 μm MIN. SOLDERING AREA : Au 0.05 μm MIN. OVER Ni 1.00 μm MIN.	TOP SIDE : Au 0.05 μm MIN. OVER Ni 1.00 μm MIN. BOTTOM SIDE : Au 0.075 μm MIN. OVER Ni 1.00 μm MIN.	TOP SIDE : Au 0.075 μm MIN. OVER Ni 1.00 μm MIN. BOTTOM SIDE : Au 0.05 μm MIN. OVER Ni 1.00 μm MIN.
20453-2**T-***	CONTACT AREA : Au 0.1 μm MIN. OVER Ni 1.00 μm MIN. SOLDERING AREA : Au 0.05 μm MIN. OVER Ni 1.00 μm MIN.	TOP SIDE : Au 0.05 μm MIN. OVER Ni 1.00 μm MIN. BOTTOM SIDE : Ni 1.00 μm MIN.(THERE IS THE POSSIBILITY THAT Au ATTACHES RANDOMLY.)	TOP SIDE : Ni 1.00 μm MIN.(THERE IS THE POSSIBILITY THAT Au ATTACHES RANDOMLY.) BOTTOM SIDE : Au 0.03 μm MIN. OVER Ni 1.00 μm MIN.

NO.	DISCRIPTION	MATERIAL	FINISH, REMARKS
5	PULL-BAR	SUS	
4	SHELL-B	PHOSPHOR BRONZE	SEE ABOVE TABLE.1
3	SHELL-A	PHOSPHOR BRONZE	SEE ABOVE TABLE.1
2	CONTACT	PHOSPHOR BRONZE	SEE ABOVE TABLE.1
1	HOUSING	LCP	UL94V-0, BLACK

Rev.31

Recommended P/N 20453-2**T-03(20P/30P/40P) 20453-250T-03S(50P)

WITHOUT PULL-BAR

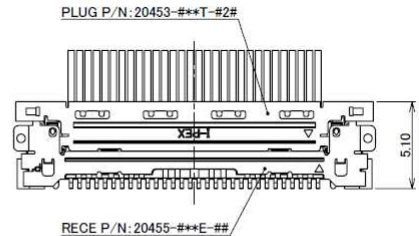
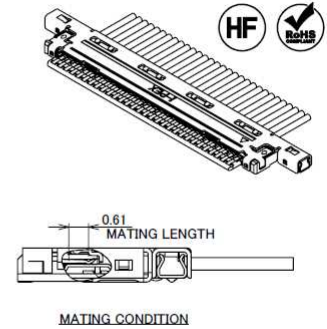
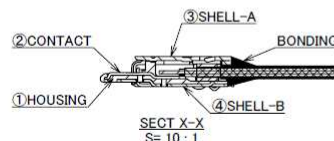
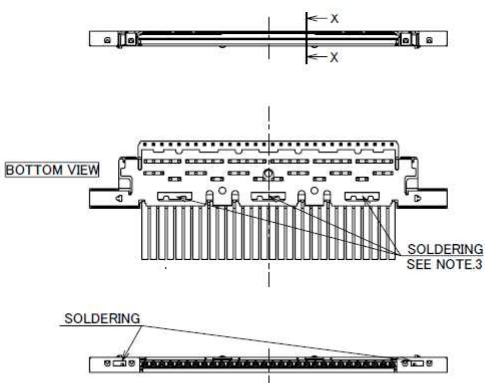
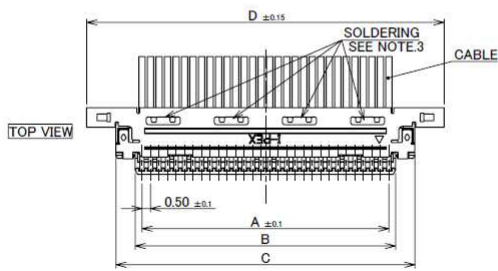

PART NO.	CABLE ASSY PART NO.	HOUSING ASSY PART NO.	SHELL-A PART NO.	PULL-BAR PART NO.
	20453-0**T-#2*	20454-0**T-**	2574-***	-
	20453-2**T-#2*	20454-2**T-**	2574-***2	-

Rev.31

Plug for Cable Assembly

Recommended P/N 20453-2**T-03(20P/30P/40P) 20453-250T-03S(50P)

WITH INSULATION COAT PULL-BAR

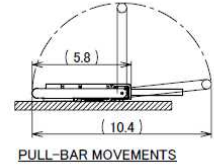
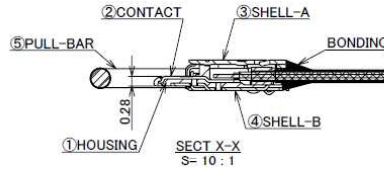
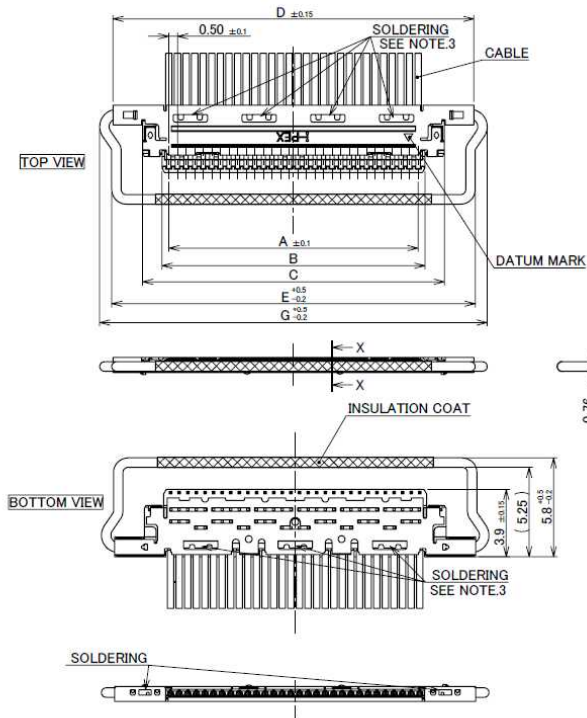
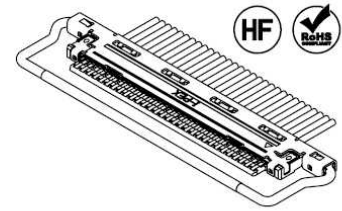

PART NO.

CABLE ASS'Y PART NO.	HOUSING ASS'Y PART NO.	SHELL-A PART NO.	PULL-BAR PART NO.
20453-0**T-#1*	20454-0**T-**	2574-***	2576-1**-**
20453-2**T-#1*	20454-2**T-**	2574-***2	2576-1**-**

Rev.31

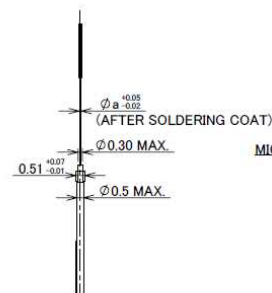
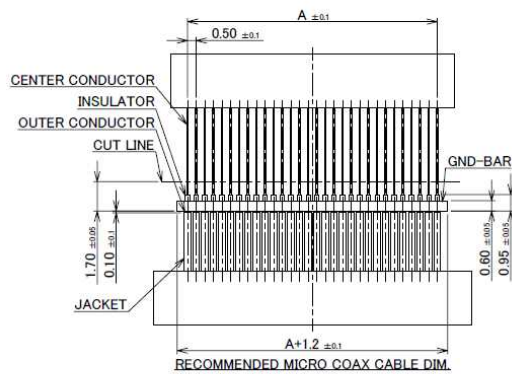

MICRO COAX CABLE DIMENSION

	a
#36	0.15
#38	0.12
#40	0.09
#42	0.075
#44	0.063

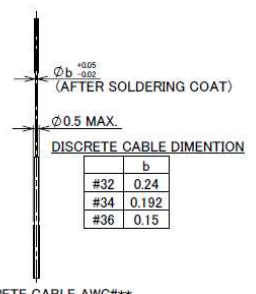
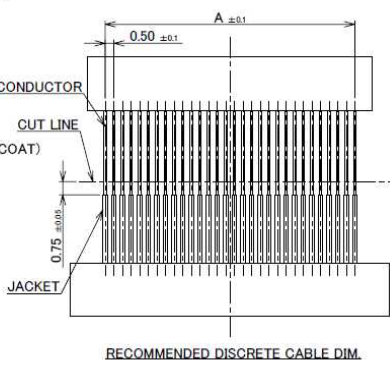
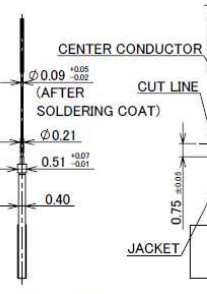
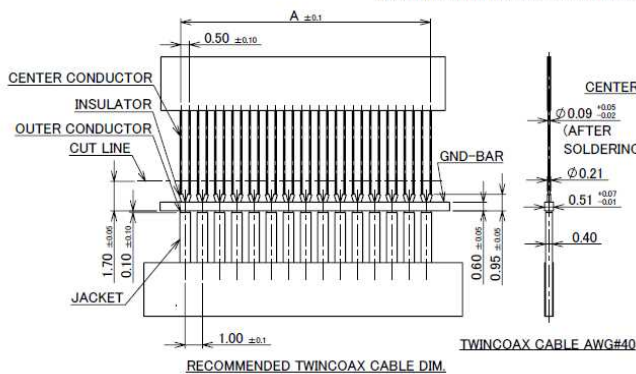

DISCRETE CABLE DIMENTION

	b
#32	0.24
#34	0.192
#36	0.15

Rev.31

Plug for Cable Assembly

THE EXTERNAL APPEARANCE

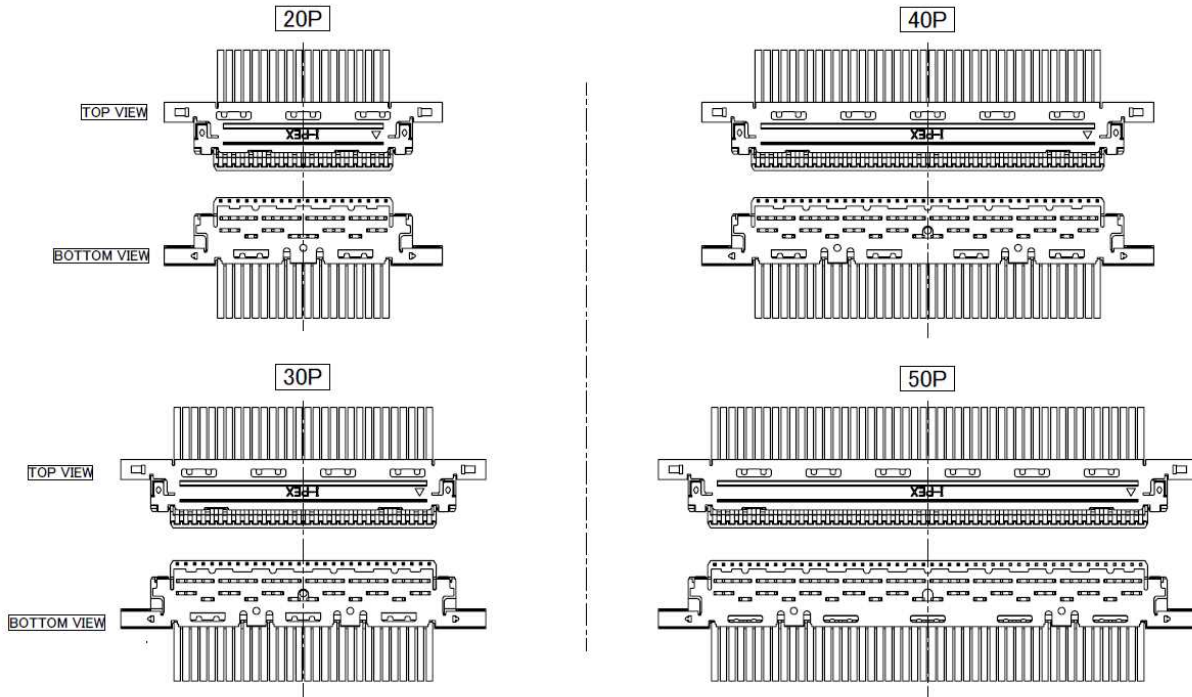

Rev.31

Plug Housing Assembly

Recommended P/N	20454-2**T								
PART NO.	Pos.	A	B	C	D	E	F	G	H
20454-#20T	20	9.50	10.30	12.56	10.20	10.55	11.00	16.00	-
20454-#30T	30	14.50	15.30	17.56	15.20	15.55	16.00	21.00	5.40
20454-#40T	40	19.50	20.30	22.56	20.20	20.55	21.00	26.00	10.40

20454-##**T : STANDARD

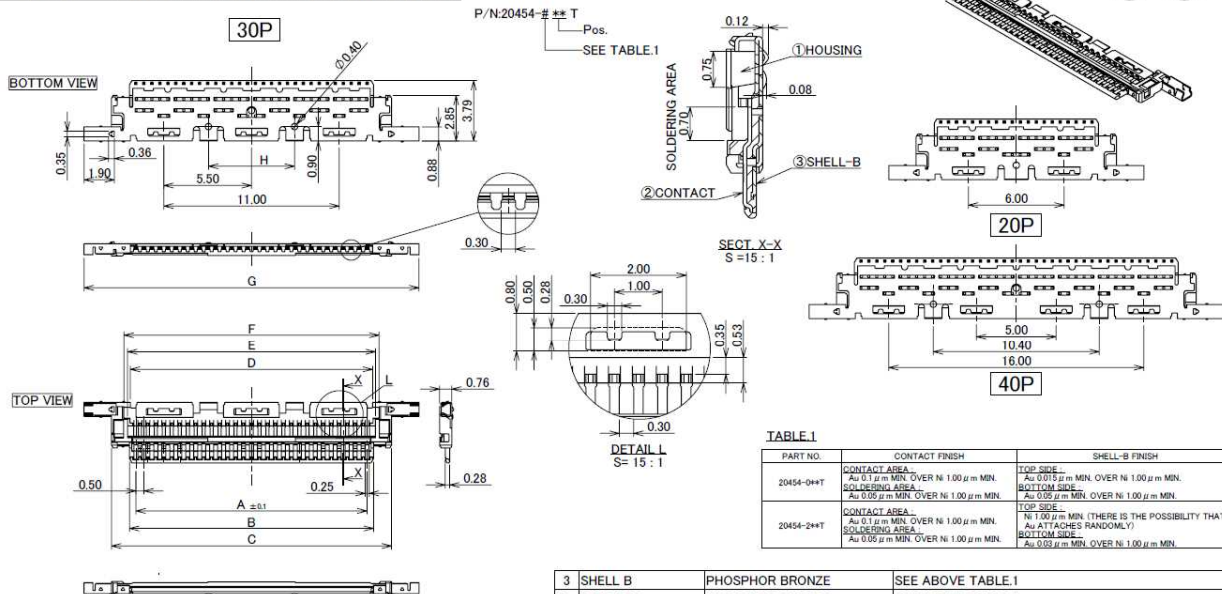

PART NO.	CONTACT FINISH	SHELL-B FINISH
20454-0#*T	CONTACT AREA: Au: 0.1 μm MIN. OVER Ni 1.00 μm MIN. SOLDERING AREA: Au: 0.05 μm MIN. OVER Ni 1.00 μm MIN.	TOP SIDE: Au: 0.015 μm MIN. OVER Ni 1.50 μm MIN. BOTTOM SIDE: Au: 0.05 μm MIN. OVER Ni 1.00 μm MIN.
20454-2#*T	CONTACT AREA: Au: 0.1 μm MIN. OVER Ni 1.00 μm MIN. SOLDERING AREA: Au: 0.05 μm MIN. OVER Ni 1.00 μm MIN.	TOP SIDE: Ni 1.00 μm MIN. (THERE IS THE POSSIBILITY THAT Au ATTACHES RANDOMLY) BOTTOM SIDE: Au: 0.05 μm MIN. OVER Ni 1.00 μm MIN.

NO	DISCRIPTION	MATERIAL	FINISH , REMARKS
3	SHELL B	PHOSPHOR BRONZE	SEE ABOVE TABLE 1
2	CONTACT	PHOSPHOR BRONZE	SEE ABOVE TABLE 1
1	HOUSING	LCP	UL94V-0, BLACK

NOTES:
 1 THIS PART IS ASSEMBLED WITH SHELL-A (P/N:2574-##*) AFTER SOLDERED THE CABLE, AND IT BECOMES P/N:20453-##*T-##*.
 2 THIS PART IS ASSEMBLED WITH SHELL-A type-H (P/N:2699-#40) AFTER SOLDERED THE CABLE, AND IT BECOMES P/N:20508-040T-##*.
 3 THIS PART IS ASSEMBLED WITH SHELL-A (P/N:2574-##*) AND ALIGNMENT COVER (P/N:2658-0***) AFTER SOLDERED THE CABLE, AND IT BECOMES P/N:20492-1**T.

Rev.19

Plug Housing Assembly

Recommended P/N		20454-250T-01	
PART NO.	Pos.		
20454-#50T-01	50		

20454-#50T-01 : TYPE-i

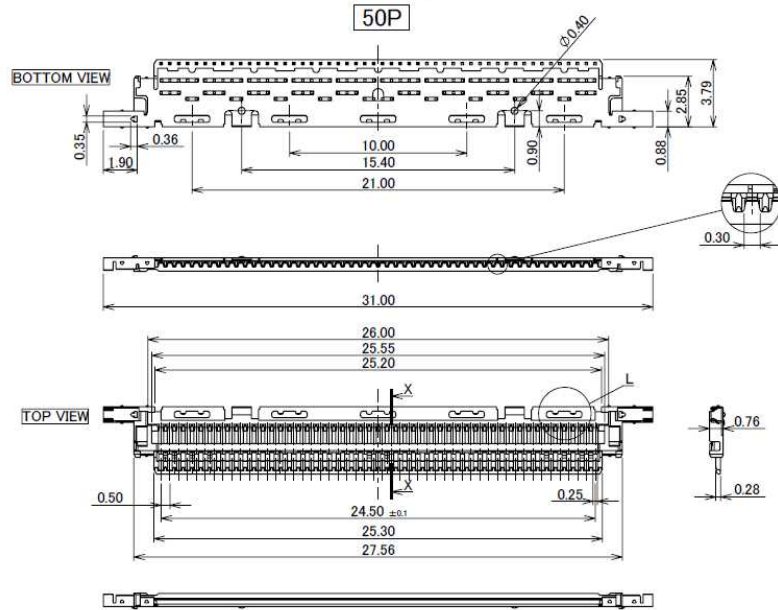

P/N:20454-#50 T-01
Pos.
SEE TABLE 2

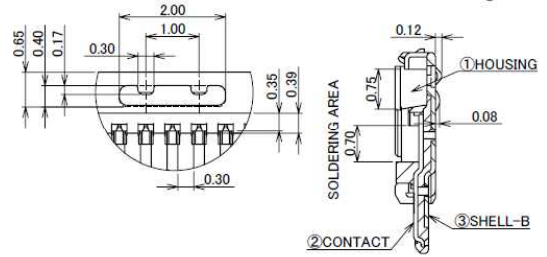

TABLE 2

PART NO.	CONTACT FINISH	SHELL-B FINISH
20454-0**T-01	CONTACT AREA: Au 0.1 μm MIN. OVER Ni 1.00 μm MIN. SOLDERING AREA: Au 0.05 μm MIN. OVER Ni 1.00 μm MIN.	TOP SIDE: Au 0.015 μm MIN. OVER Ni 1.00 μm MIN. BOTTOM SIDE: Au 0.05 μm MIN. OVER Ni 1.00 μm MIN.
20454-2**T-01	CONTACT AREA: Au 0.1 μm MIN. OVER Ni 1.00 μm MIN. SOLDERING AREA: Au 0.05 μm MIN. OVER Ni 1.00 μm MIN.	TOP SIDE: Ni 1.00 μm MIN. (THERE IS THE POSSIBILITY THAT Au ATTACHES RANDOMLY) BOTTOM SIDE: Au 0.05 μm MIN. OVER Ni 1.00 μm MIN.

NO.	DISCRIPTION	MATERIAL	FINISH , REMARKS
3	SHELL B	PHOSPHOR BRONZE	SEE ABOVE TABLE.2
2	CONTACT	PHOSPHOR BRONZE	SEE ABOVE TABLE.2
1	HOUSING	LCP	UL94V-0. BLACK

Rev.19

Pull Bar

Recommended P/N		2576-1**-00	
PART NO.	Pos.	A	B
2576-#20-00	20	15.05	16.45
2576-#30-00	30	20.05	21.45
2576-#40-00	40	25.05	26.45
2576-#50-00	50	30.05	31.45

2576-0**-00



P/N: 2576-#**-00
POS.
0 : WITHOUT INSULATION COAT
1 : WITH INSULATION COAT

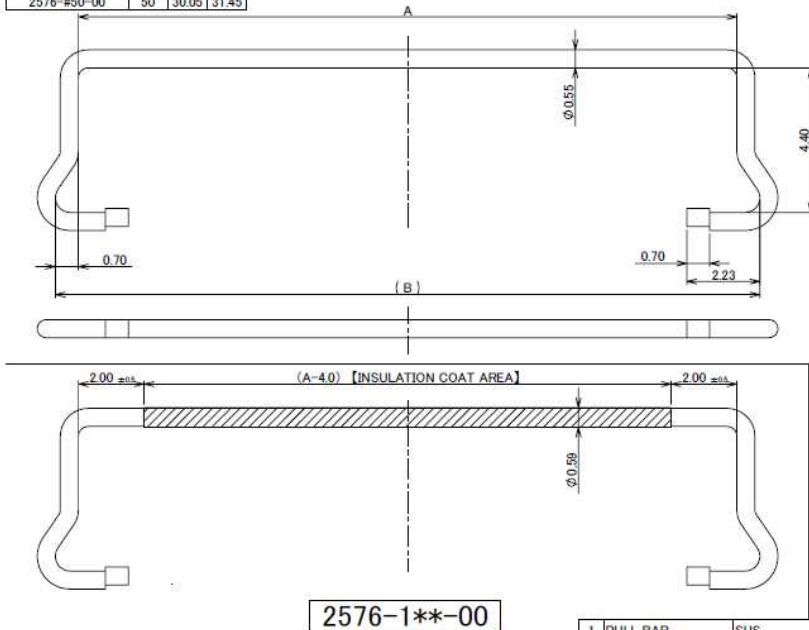

2576-1**-00

NO.	DISCRIPTION	MATERIAL	FINISH , REMARKS
1	PULL BAR	SUS	-

Rev.14

Shell-A

Recommended P/N		2574-0**2			
PART NO.	Pos.	A	B	C	D
2574-#20#	20	9.78	12.56	16.00	8.00 [= 4.0 × (3-1)]
2574-#30#	30	14.78	17.56	21.00	12.00 [= 4.0 × (4-1)]
2574-#40#	40	19.78	22.56	26.00	16.00 [= 4.0 × (5-1)]
2574-#50#	50	24.78	27.56	31.00	20.00 [= 4.0 × (6-1)]



P/N:2574-###
 SEE TABLE.1
 Pos.
 0 : WITH DATUM MARK
 1 : WITHOUT DATUM MARK

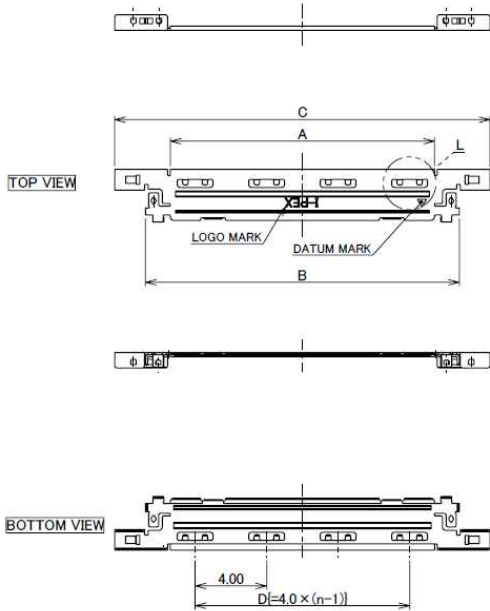
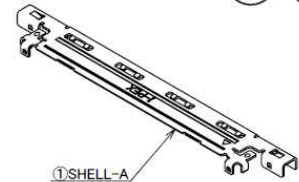

TABLE.1

PART NO.	SHELL-A FINISH
2574-###	TOP SIDE : Au 0.05 μm MIN. OVER Ni 1.00 μm MIN. BOTTOM SIDE : Au 0.015 μm MIN. OVER Ni 1.00 μm MIN.
2574-###2	TOP SIDE : Au 0.03 μm MIN. OVER Ni 1.00 μm MIN. BOTTOM SIDE : Ni 1.00 μm MIN. (THERE IS THE POSSIBILITY THAT Au ATTACHES RANDOMLY)

NO.	DISCRIPTION	MATERIAL	FINISH , REMARKS
1	SHELL A	PHOSPHOR BRONZE	SEE ABOVE TABLE.1

Rev.14

Receptacle Assembly

Recommended P/N		20455-0**E-76 (30P/40P/50P)				20455-A20E-76 (20P)	
PART NO.	Pos.	A	B	C	D		

20455-020E-#2	20	9.50	11.30	16.25	14.47		
20455-030E-##	30	14.50	16.30	21.25	19.47		
20455-040E-##	40	19.50	21.30	26.25	24.47		
20455-050E-##	50	24.50	26.30	31.25	29.47		

P/N:20455-0**E-##
 SEE TABLE.1
 Pos.

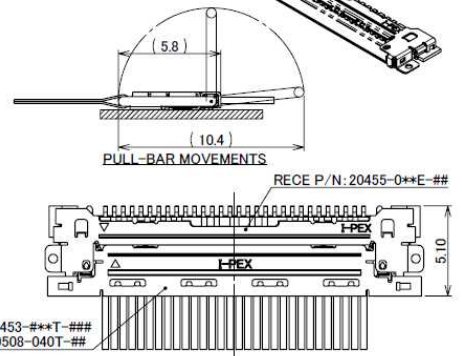
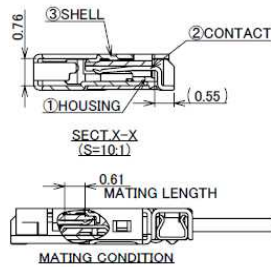
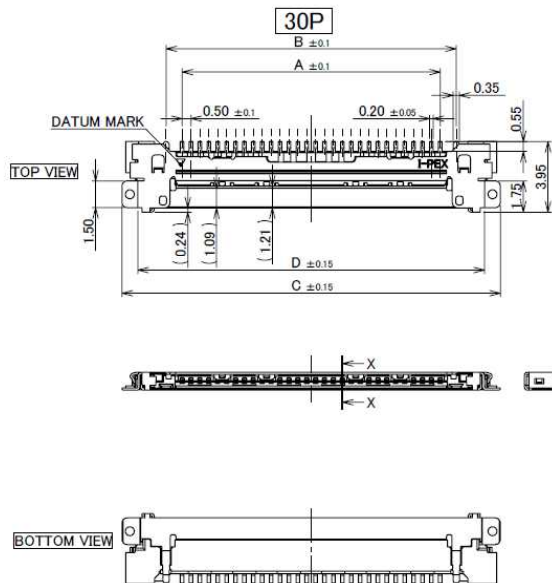

TABLE.1

PART NO.	DATUM MARK	CONTACT FINISH	SHELL FINISH
20455-0**E-02	WITH	CONTACT AREA Au 0.1 μm MIN. OVER Ni 1.00 μm MIN. SOLDERING AREA Au 0.05 μm MIN. OVER Ni 1.00 μm MIN.	Au 0.02 μm MIN. OVER Ni 1.00 μm MIN.
20455-0**E-12	WITHOUT	CONTACT AREA Au 0.1 μm MIN. OVER Ni 1.00 μm MIN. SOLDERING AREA Au 0.05 μm MIN. OVER Ni 1.00 μm MIN.	Au 0.01 μm MIN. OVER Ni 1.00 μm MIN.
20455-0**E-66	WITH	CONTACT AREA Au 0.1 μm MIN. OVER Ni 1.00 μm MIN. SOLDERING AREA Au 0.05 μm MIN. OVER Ni 1.00 μm MIN.	Au 0.01 μm MIN. OVER Ni 1.00 μm MIN.
20455-0**E-76	WITHOUT	CONTACT AREA Au 0.1 μm MIN. OVER Ni 1.00 μm MIN. SOLDERING AREA Au 0.05 μm MIN. OVER Ni 1.00 μm MIN.	Au 0.01 μm MIN. OVER Ni 1.00 μm MIN.

NO.	DISCRIPTION	MATERIAL	FINISH , REMARKS
3	SHELL	PHOSPHOR BRONZE	SEE ABOVE TABLE.1
2	CONTACT	PHOSPHOR BRONZE	SEE ABOVE TABLE.1
1	HOUSING	LCP	UL94V-0, BLACK

Rev.28

Receptacle Assembly

Recommended P/N	20455-0**E-76 (30P/40P/50P)	20455-A20E-76 (20P)
-----------------	-----------------------------	---------------------

PART NO.	Pos.	A	B	C	D	H	J
20455-A20E-##	20	9.50	11.30	16.25	14.47	15.32	15.84

TYPE-A

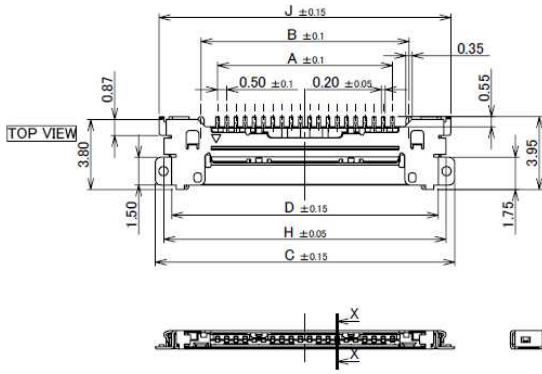

BOTTOM VIEW

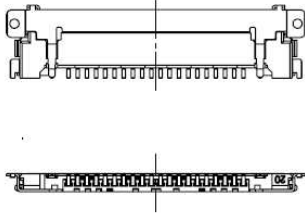

P/N:20455-A20E-##
A: TYPE-A
SEE TABLE 2

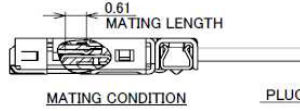
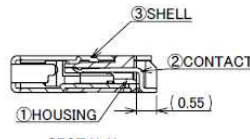
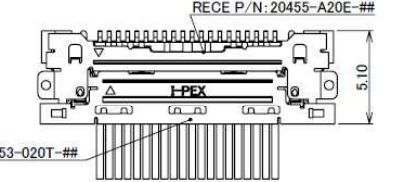
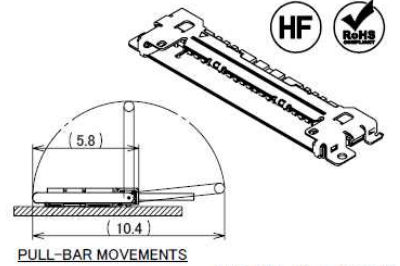

TABLE 2



PART NO.	DATUM MARK	CONTACT FINISH	SHELL FINISH
20455-A20E-02	WITH	CONTACT AREA Au 0.1 μm MIN. OVER Ni 1.00 μm MIN. SOLDERING AREA Au 0.05 μm MIN. OVER Ni 1.00 μm MIN.	Au 0.02 μm MIN. OVER Ni 1.00 μm MIN.
20455-A20E-12	WITHOUT	CONTACT AREA Au 0.1 μm MIN. OVER Ni 1.00 μm MIN. SOLDERING AREA Au 0.05 μm MIN. OVER Ni 1.00 μm MIN.	Au 0.01 μm MIN. OVER Ni 1.00 μm MIN.
20455-A20E-66	WITH	CONTACT AREA Au 0.1 μm MIN. OVER Ni 1.00 μm MIN. SOLDERING AREA Au 0.05 μm MIN. OVER Ni 1.00 μm MIN.	Au 0.01 μm MIN. OVER Ni 1.00 μm MIN.
20455-A20E-76	WITHOUT	CONTACT AREA Au 0.1 μm MIN. OVER Ni 1.00 μm MIN. SOLDERING AREA Au 0.05 μm MIN. OVER Ni 1.00 μm MIN.	Au 0.01 μm MIN. OVER Ni 1.00 μm MIN.

NO.	DISCRIPTION	MATERIAL	FINISH, REMARKS
3	SHELL	PHOSPHOR BRONZE	SEE ABOVE TABLE 1
2	CONTACT	PHOSPHOR BRONZE	SEE ABOVE TABLE 1
1	HOUSING	LCP	UL94V-0, BLACK

Rev.28

PART NO.	Pos.	A	B	E	F	G	H	J	K
20455-#20E-##	20	9.50	11.30	14.30	10.60	18.20	15.32	15.84	14.84
20455-030E-##	30	14.50	16.30	19.30	15.60	23.20	-	-	-
20455-040E-##	40	19.50	21.30	24.30	20.60	28.20	-	-	-
20455-050E-##	50	24.50	26.30	29.30	25.60	33.20	-	-	-

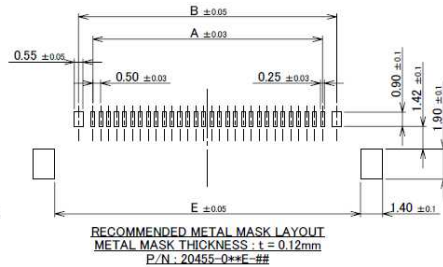
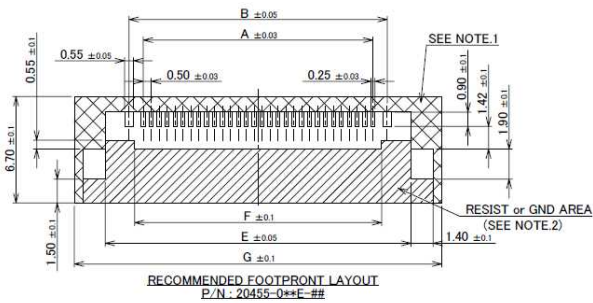

TYPE-A

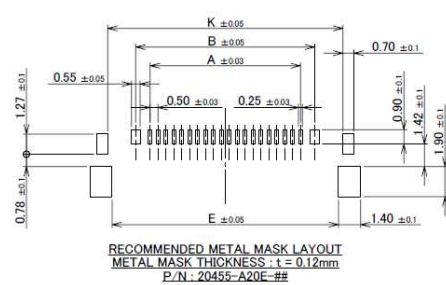
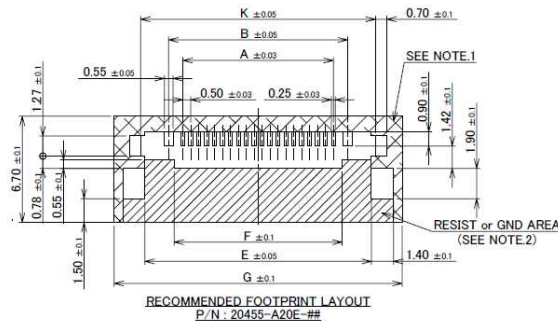

- NOTES.
1. IN CASE OF PLUG WITH PULL-BAR.
THIS AREA CANNOT MOUNT ANOTHER COMPONENTS.
2. SOLDER RESIST SHALL BE APPLIED TO PREVENT SHORT CIRCUITS
WHEN PLACING SIGNAL LINES ON GROUND AREA.

Rev.28

Receptacle Assembly

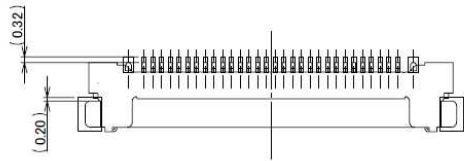

CONNECTOR ON RECOMMENDED FOOTPRINT PATTERN
P/N : 20455-0**E-##

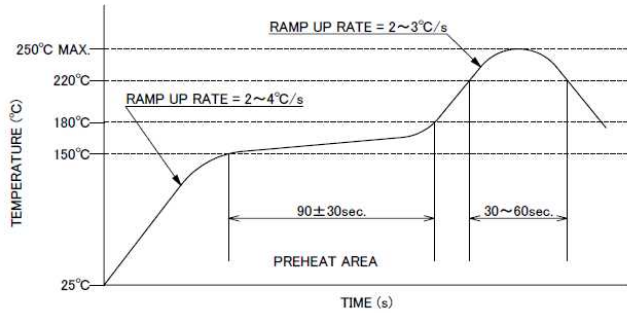

REFLOW TEMPERATURE PROFILE
SENJU METAL INDUSTRY CO., LTD. : M705-SHF(Sn96.5 Ag3.0 Cu0.5)

TYPE-A

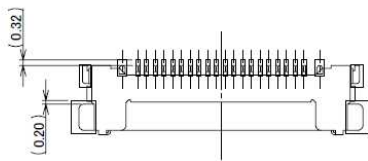

CONNECTOR ON RECOMMENDED FOOTPRINT PATTERN
P/N : 20455-A20E-##

Rev.28

ITEMS	SPECIFICATION
APPLICABLE CABLE	MICRO COAX : AWG# 44, 42, 40, 38, 36 DISCRETE : AWG# 36, 34, 32 TWINCOAX : AWG# 40
RATING VOLTAGE	100V AC (PER CONTACT)
RATING AMPERAGE (FOR CONTACT)	0.1A AC/DC [AWG#44] PER CONTACT/UP TO 50 CONTACTS 0.24A AC/DC [AWG#42] PER CONTACT/UP TO 50 CONTACTS 0.3A AC/DC [AWG#40] PER CONTACT/UP TO 50 CONTACTS 0.5A AC/DC [AWG#38] PER CONTACT/UP TO 14 CONTACTS 0.8A AC/DC [AWG#36] PER CONTACT/UP TO 10 CONTACTS 1.0A AC/DC [AWG#34] PER CONTACT/UP TO 6 CONTACTS 1.0A AC/DC [AWG#32] PER CONTACT/UP TO 6 CONTACTS TESTING BY A REAL MACHINE IS RECOMMENDED BECAUSE TEMPERATURE RISE MAY AFFECTED BY ACTUAL SITUATION.
OPERATING TEMPERATURE	233~358K(-40°C~+85°C)
OPERATING HUMIDITY	85% R.H. MAX.(NON-CONDENSING)
CONTACT RESISTANCE	INITIAL : 140mohm MAX.(AWG#32) / AFTER TEST : \triangleleft40mohm MAX. 180mohm MAX.(AWG#34) 275mohm MAX.(AWG#36) 360mohm MAX.(AWG#38) 600mohm MAX.(AWG#40) 700mohm MAX.(AWG#42) 1080mohm MAX.(AWG#44)
GROUND SHELL RESISTANCE	INITIAL : 50mohm MAX. / AFTER TEST : \triangleleft40mohm MAX.
INSULATION RESISTANCE	INITIAL : 1000mohm MIN. / AFTER TEST : 500mohm MIN.
DIELECTRIC WITHSTANDING VOLTAGE	AC250V 1min
DURABILITY	30 CYCLES
MATING FORCE (INITIAL / AFTER TEST)	20P : 9.45N MAX. 30P : 12.15N MAX. 40P : 16.20N MAX. 50P : 20.25N MAX.
UNMATING FORCE (INITIAL / AFTER TEST)	20P : 2.0N MIN. 30P : 3.0N MIN. 40P : 4.0N MIN. 50P : 5.0N MIN.
CABLE RETENTION FORCE	20P : 9.80N MIN. 30P : 14.70N MIN. 40P : 19.60N MIN. 50P : 24.50N MIN.
COPLANARITY	0.10 MAX.
PRODUCT SPECIFICATION	PRS-1427
TEST REPORT	TR-08047 (20455-##*E-#2) TR-13084 (20455-##*E-#6, 20455-0**E-#8)
PACKING STANDARD	300-643
INSTRUCTION MANUAL	HIM-08004

Rev.28

Board to Board



High-Density



Autolocking FPC/FFC

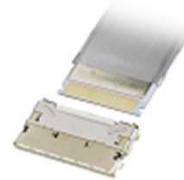

High-Density



FPC/FFC



Micro-Coaxial / Discrete Cable



High-Speed



RF



High-Frequency



Optical Module



High-Speed



Power



High-Power



I/O (Input/Output)



Quick charge



Effector



Custom Connectors Available

Inquiry



I-PEX, MHF, CABLINE, NOVASTACK, EVAFLEX, MINIFLEX, ISH, IARPB, IASLP, ESTORQ, ISFIT, i-Fit and ZenShield are registered trademarks of I-PEX Inc. Please note that the contents in the catalog might be changed without prior notification. I-PEX Inc. assumes no responsibility for any inaccuracies or obligation to update information on these documents. Please be sure to read and understand the latest "Precautions for Use" and "Instruction Manual" before you use our products. We shall not be responsible for any defects, damages or troubles in case you use our products without following the precautions for use. Please feel free to contact our sales representatives when you use our products for any applications that require very high reliability and safety, or that relate to human life (ex. nuclear power control, aerospace, transportation, medical equipment, safety equipment etc.).

Contact your sales representative or more detailed information.

www.i-pex.com



I-PEX

© I-PEX Inc. 2022
All rights reserved.

单击下面可查看定价，库存，交付和生命周期等信息

[>>I-PEX](#)