

Recommended P/N 2574-0\*\*2

| PART NO.  | Pos. | A     | B     | C     | D                     |
|-----------|------|-------|-------|-------|-----------------------|
| 2574-#20# | 20   | 9.78  | 12.56 | 16.00 | 8.00 [= 4.0 × (3-1)]  |
| 2574-#30# | 30   | 14.78 | 17.56 | 21.00 | 12.00 [= 4.0 × (4-1)] |
| 2574-#40# | 40   | 19.78 | 22.56 | 26.00 | 16.00 [= 4.0 × (5-1)] |
| 2574-#50# | 50   | 24.78 | 27.56 | 31.00 | 20.00 [= 4.0 × (6-1)] |



P/N:2574-#\*\*#  
 SEE TABLE.1  
 Pos.  
 0 : WITH DATUM MARK  
 1 : WITHOUT DATUM MARK

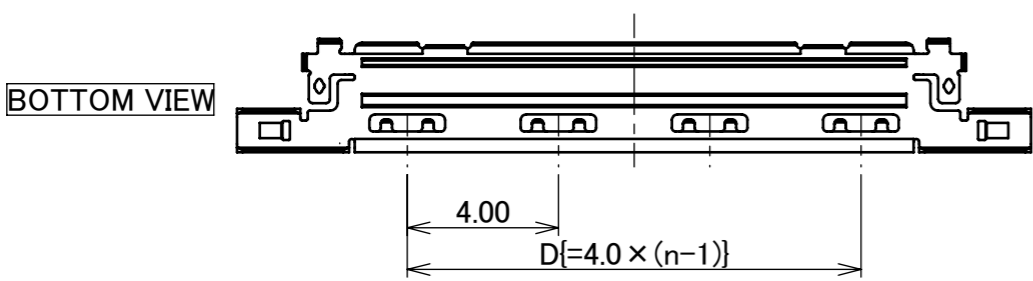
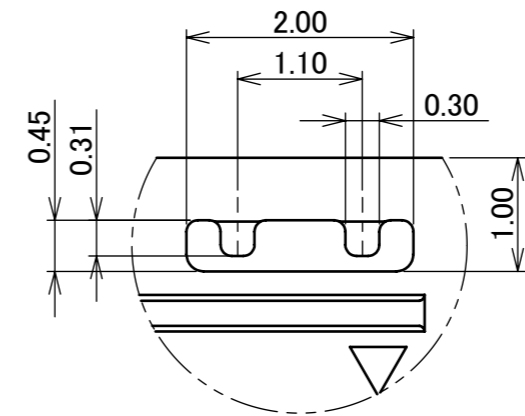
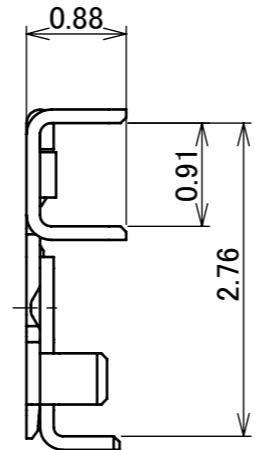
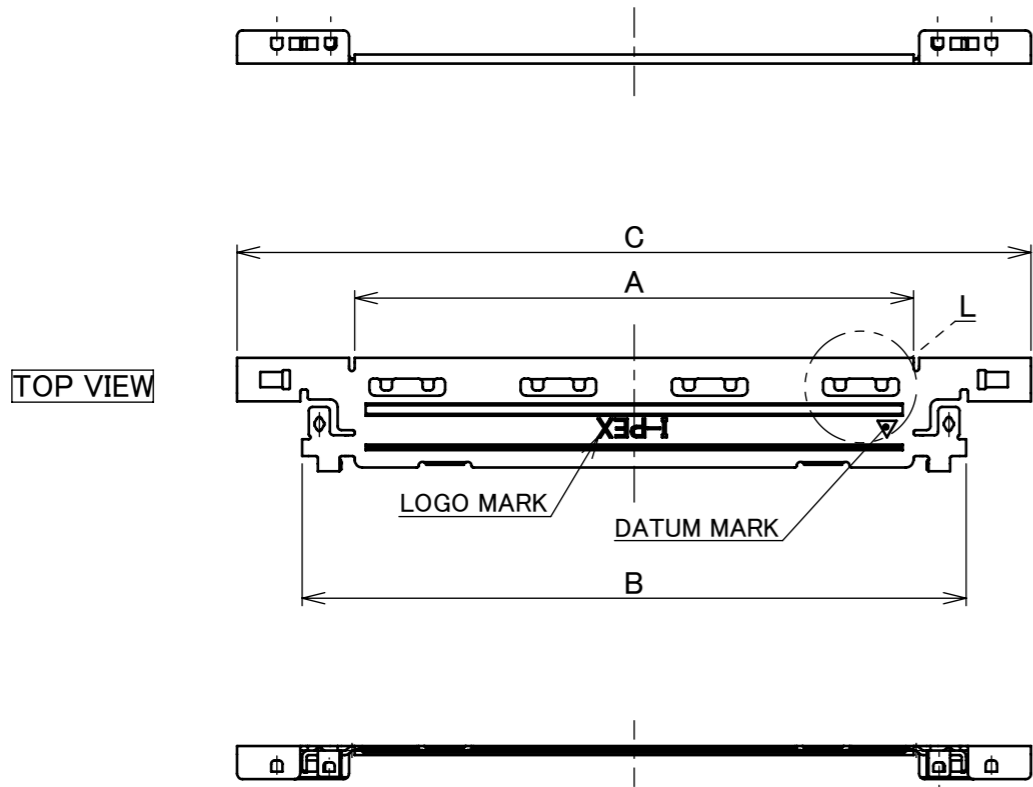
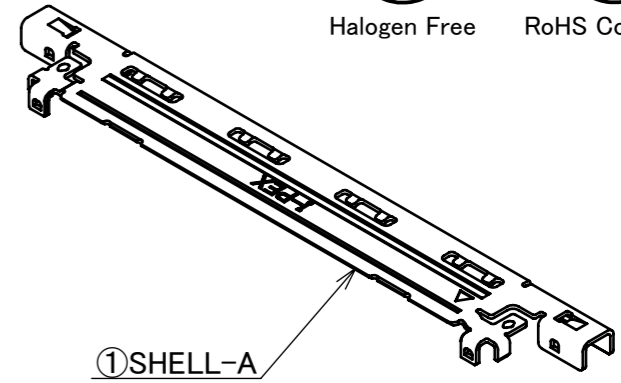

TABLE.1

| PART NO.  | SHELL-A FINISH  |
|-----------|---|
| 2574-***  | TOP SIDE :<br>Au 0.05 μm MIN. OVER Ni 1.00 μm MIN.<br>BOTTOM SIDE :<br>Au 0.015 μm MIN. OVER Ni 1.00 μm MIN.                                |
| 2574-***2 | TOP SIDE :<br>Au 0.03 μm MIN. OVER Ni 1.00 μm MIN.<br>BOTTOM SIDE :<br>Ni 1.00 μm MIN. (THERE IS THE POSSIBILITY THAT Au ATTACHES RANDOMLY) |

| NO. | DISCRIPTION | MATERIAL        | FINISH , REMARKS  |
|-----|-------------|-----------------|-------------------|
| 1   | SHELL A     | PHOSPHOR BRONZE | SEE ABOVE TABLE.1 |

|                 |         |       |              |      |                    |          |                  |                                       |                 |                  |               |      |
|-----------------|---------|-------|--------------|------|--------------------|----------|------------------|---------------------------------------|-----------------|------------------|---------------|------|
| 15              | Z221440 | T.Ono | Dec./20/'22  | H.I  | ANGLE              | ±2°      | 6 OVER 30 MAX.   | ±0.3                                  | PROJECTION<br>⊕ | SERIES No.<br>R3 | CUSTOMER COPY |      |
| 14              | Z201153 | T.Ono | Nov./05/'20  | H.I  | 6 MAX.             | ±0.2     | 30 OVER 120 MAX. | ±0.5                                  |                 |                  |               |      |
| 13              | Z191177 | R.M   | Sept./16/'19 | H.I  | GENERAL TOLERANCE. |          |                  | TITLE<br>CABLINE® -VS<br>PLUG SHELL-A | SCALE<br>5:1    | UNIT<br>mm       | I-PEX         |      |
| 12              | Z180941 | A.K   | July/18/'18  | H.I  | DWG.               | DATE     |                  |                                       |                 |                  |               |      |
| 11              | Z180796 | A.K   | June/20/'18  | H.I  | H.Ikari            |          | 2008/04/16       |                                       |                 |                  |               |      |
| 10              | Z151047 | H.I   | Sept./23.'15 | Y.S  | CHK.               |          |                  |                                       |                 |                  |               |      |
| REV.            | ECN     | BY    | DATE         | APP. | APP.               | E.Kawabe |                  | DWG. No.                              | 2574            | SIZE             | SHEET         | REV. |
| REVISION RECORD |         |       |              |      |                    |          |                  |                                       |                 | A3               | 1/2           | 15   |

PATENT REGISTERED

| PART NO.  | E  | F  | QTY. PER EMBOSS REEL<br>(PIECES / REEL) | QTY. PER PACKING CARTON<br>(REELS / CARTON) | PACKING STANDARD |
|-----------|----|----|---|---|------------------|
| 2574-#20# | 30 | 23 | 5000 PIECES / REEL                      | 3 REELS / CARTON = 15000                    | 300-642          |
| 2574-#30# | 35 | 28 |   |   |                  |
| 2574-#40# | 40 | 33 |   |   |                  |
| 2574-#50# | 45 | 38 |   |   |                  |

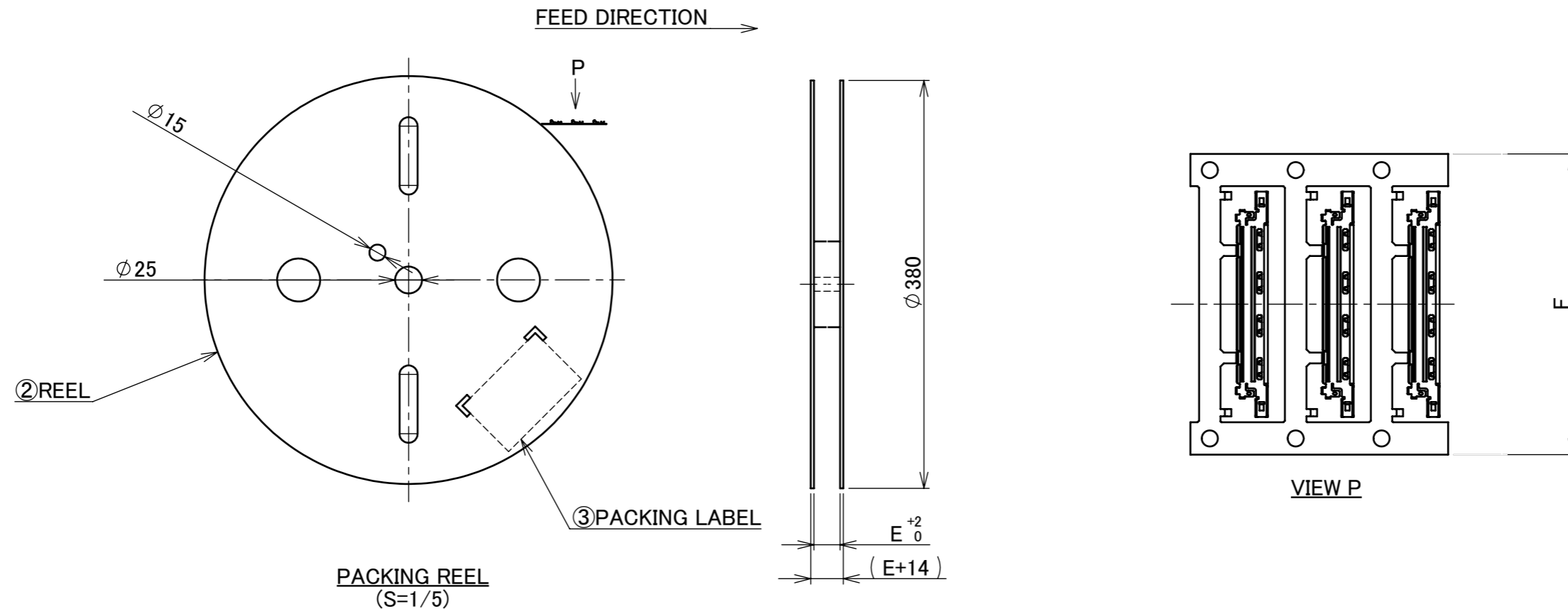

| NO. | DISCRIPTION   | MATERIAL  | FINISH , REMARKS |
|-----|---------------|-----------|------------------|
| 3   | PACKING LABEL | -         | -                |
| 2   | REEL          | CARDBOARD | -                |

| ANGLE              | $\pm 2^\circ$ | 6 OVER 30 MAX.   | $\pm 0.3$ | PROJECTION                              | SERIES No. | CUSTOMER COPY  |  |  |      |       |      |
|--------------------|---------------|------------------|-----------|---|------------|--|--|--|------|-------|------|
| 6 MAX.             | $\pm 0.2$     | 30 OVER 120 MAX. | $\pm 0.5$ |   | R3         | <div style="display: flex; align-items: center;"> <div style="margin-right: 10px;">           SCALE<br/>5:1<br/>UNIT<br/>mm         </div> <div style="font-size: 24px; font-weight: bold;">I-PEX</div> </div> |  |  |      |       |      |
| GENERAL TOLERANCE. |               |                  |           | TITLE                                   |            |  |  |  | SIZE | SHEET | REV. |
| DWG.               | DATE          |                  |           | CABLIN <sup>®</sup> -VS<br>PLUG SHELL-A |            |  |  |  | A3   | 2/2   | 15   |
| CHK.               |               |                  |           | DWG. No.                                |            |  |  |  |      |       |      |
| APP.               |               |                  |           | 2574                                    |            |  |  |  |      |       |      |

单击下面可查看定价，库存，交付和生命周期等信息

[>>I-PEX](#)