

REVISION HISTORY			
REV	DESCRIPTION	DATE	APPROVED
A	신규 제정	2009.04.05	P.K.KO
B	BOTTOM면 R치수 변경 0.1 R	2010.08.23	P.K.KO
C	인입부 공차 변경 0.85 +0.15 -0.05	2012.02.17	P.K.KOH
D	SHIELD CASE THICKNESS 0.2 ±0.02 ⇒ 0.2 + 0.02 -0	2012.03.30	P.K.KOH

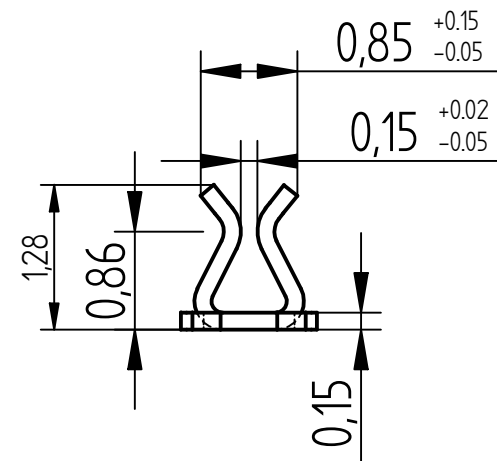

SCALE 15 / 1

Taping 사양도 SCALE 2:1

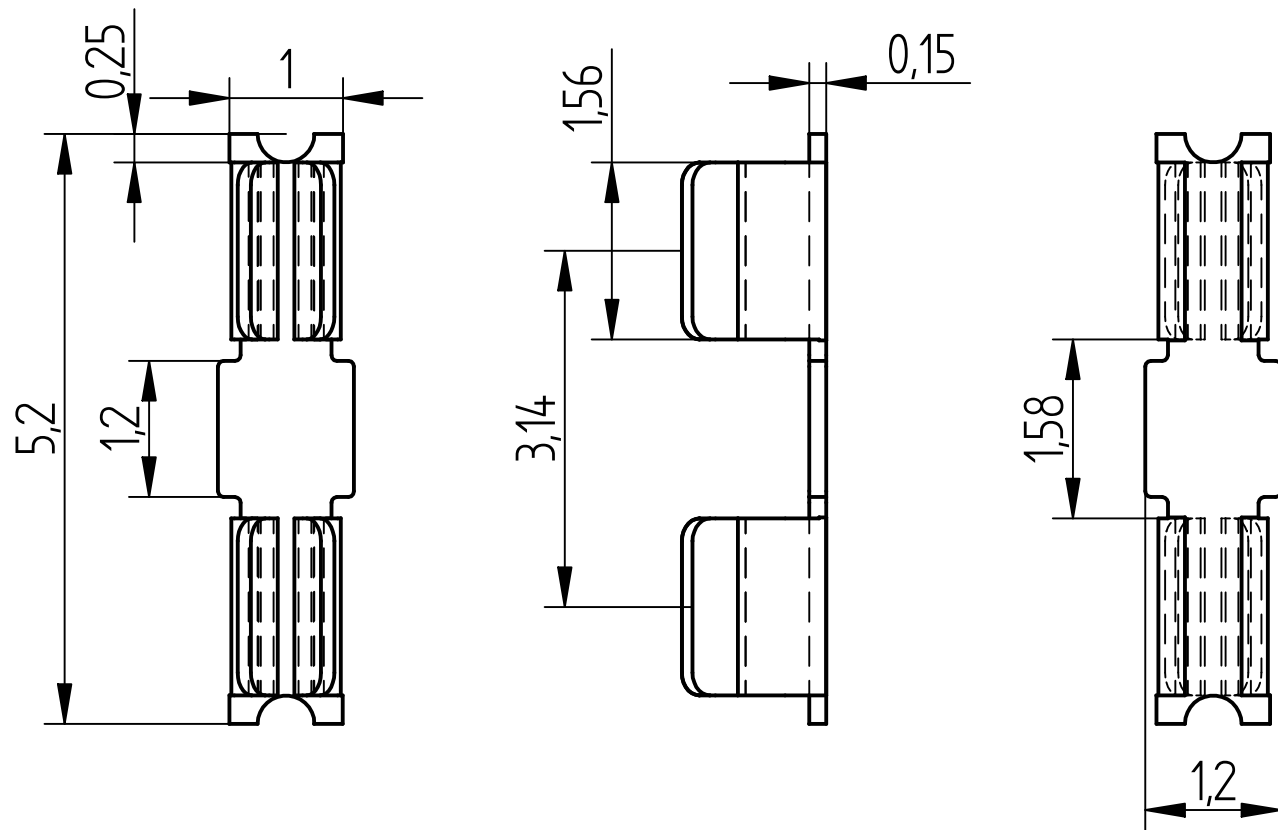
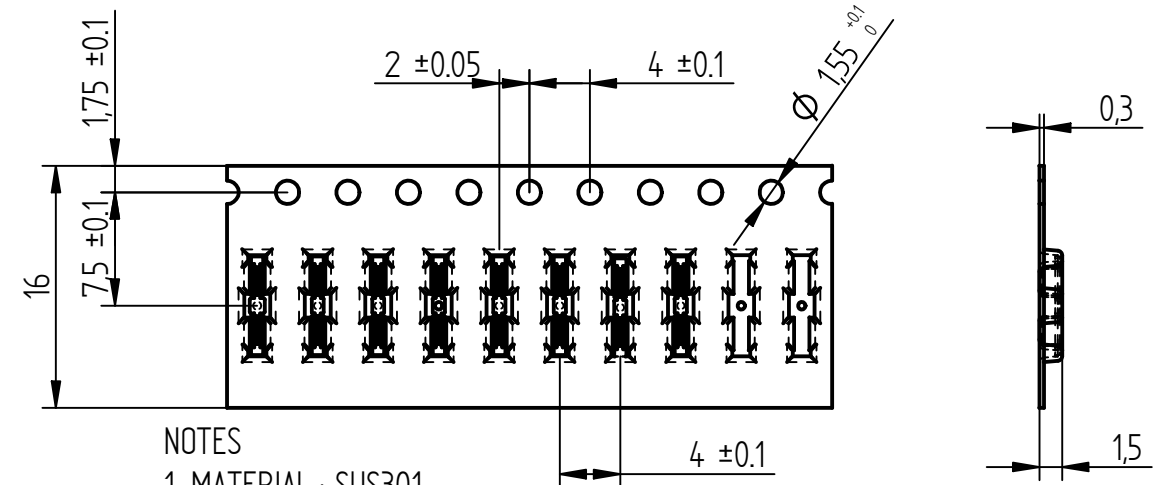

NOTES

- MATERIAL : SUS301
- MATERIAL THICKNESS : 0.15t
- FINISHED : Sn(100%) PLATING ON BOTH SIDE  
( Ni0.5µm Sn1.27µm )
- PACKING MATERIALS.  
- REEL : HIPS 0.3t  
- COVER TAPE : PS  
- Q'TY/REEL : 10,000ea
- AVAILABLE SHIELD CASE THICKNESS : 0.2+0.02-0
- CONTACT RESISTANCE 300mmΩ MAX
- INTENTION FORCE/RETENTION FORCE SPEC

	INTENTION FORCE	RETENTION FORCE
SPEC	MAX 1.2Kg	MIN 0.5Kg

8. STENCIL THICKNESS : 0.12T

9. Maintain 90° ±3 while engage & disengage shield can & shield clip to prevent deformation & to maintain retention force of shield clip

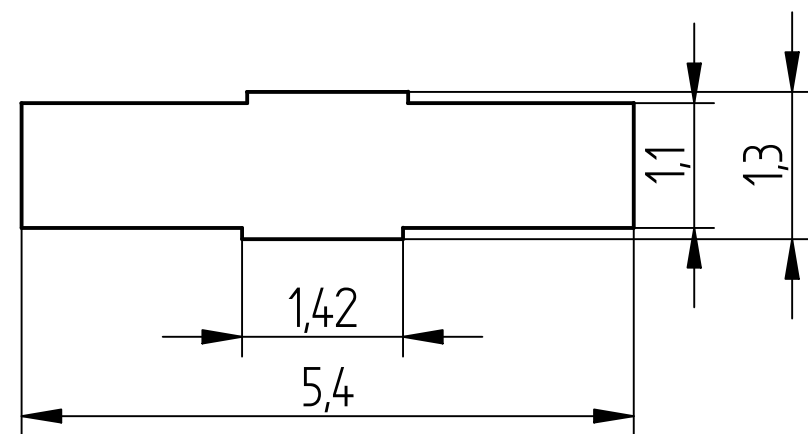

RECOMMENDED PCB LAYOUT

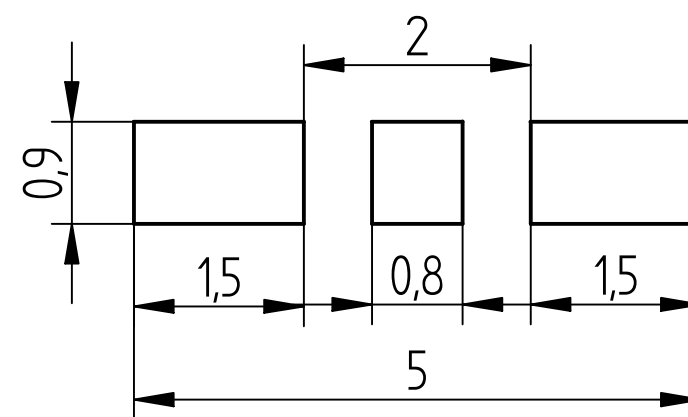

RECOMMENDED STENCIL LAY-OUT 0.1T

UNLESS OTHERWISE SPECIFIED  
DIMENSIONS ARE IN MILLIMETERS  
TOLERANCES ARE  
ANGLES ± 0.3°  
0 ~ 1 ± 0.05  
1 ~ 5 ± 0.1  
5 ~ 10 ± 0.15

INNOCHIPS TECHNOLOGY  
**IGT** (주)이노칩테크놀로지  
Solution Provider

TITLE SHILED CLIP		
SIZE A3	DWG NO ICSRC-52128SFR	REV D
FILE NAME: ICSRC-52128SFR.dft		
SCALE:	WEIGHT:	SHEET 1 OF 1

单击下面可查看定价，库存，交付和生命周期等信息

[>>ICT](#)