

# 3.0kW Dual LLC Evaluation Board

EVAL\_3KW\_2LLC\_P7\_47  
T0247



# Table of Contents

1

General Description

2

Efficiency Results

3

Design Concept

# Table of Contents

1 General Description

2 Efficiency Results

3 Design Concept

# General

## Description:

The "EVAL\_3KW\_2LLC\_P7\_47" - Evaluation Board shows how to design a dual phase LLC system solution of a Server SMPS with the target to meet **80+ Titanium Standard** efficiency requirements. On this purpose there has been applied latest CoolMOS™ technology [IPP60R037P7](#) 600V Power MOSFET on the primary side and OptiMOS™ Low Voltage Power MOSFET in SuperSO8 [BSC093N15NS5](#) in the synchronous rectification secondary stage, in combination with QR CoolSET™ [ICE2QR2280Z](#), [1EDI60N12AF](#) [EiceDRIVER™](#) high voltage, high speed driver ICs for HV [MOSFETs](#), Low Side Gate Driver [2EDN7524R](#) for SR MOSFETs and digital LLC Controller [XMC4400](#).

## Summary of Features:

- › Output voltage: 44 – 58 VDC
- › Output current max: 55A
- › Peak efficiency @ 50% load > 98.4%
- › Efficiency @ 10% load > 97%

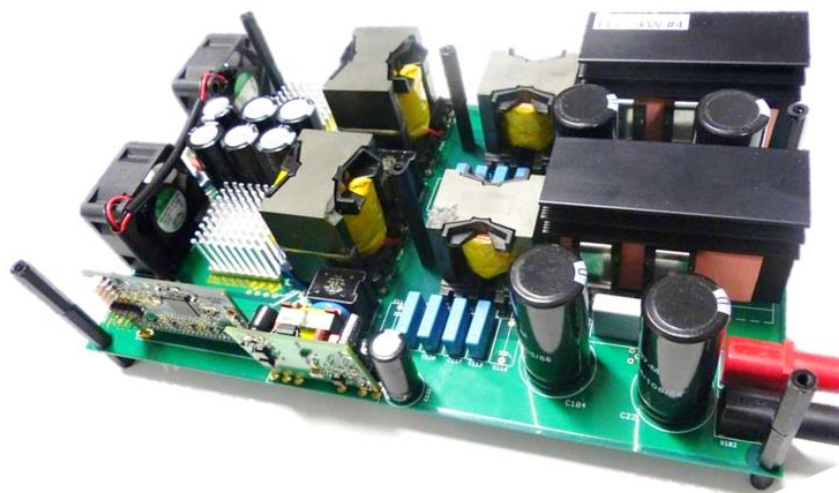

## The following variants are available:

- › EVAL\_3kW\_2LLC\_P7 version with CoolMOS™ P7 **TO-247**, IPW60R037P7

Ordercode: EVAL\_3KW\_2LLC\_P7\_47

# Example of System Understanding: Infineon Demo Solution for Titanium HV DC/DC stage



Half Bridge LLC with synchronous rectification in center tap configuration

$V_{in}$	350 – 400V <sub>DC</sub>
$V_{in\_nom}$	380V <sub>DC</sub>
$V_{out}$	44 - 58 V <sub>DC</sub>
$I_{out}$	55 A
$P_o$	3 kW
$C_r$	66 nF
$L_r$	12 $\mu$ H
$L_m$	62 $\mu$ H

### Primary HV MOSFETs

- > **CoolMOS™ IPP60R037P7**  
Reduced Gate Charge ( $Q_g$ )
- > Reduced  $E_{off}$
- > High body diode ruggedness

### SR MOSFETs

- > **OptiMOS™ BSC093N15NS5**
- > New generation
- > Best FOM  $R_{DS(on)} \times Q_g$
- > Best FOM  $R_{DS(on)} \times Q_{oss}$

**Transformer**  
SP-PQ 40/40 core

**Resonant inductor**  
SP-PQ 35/35 core

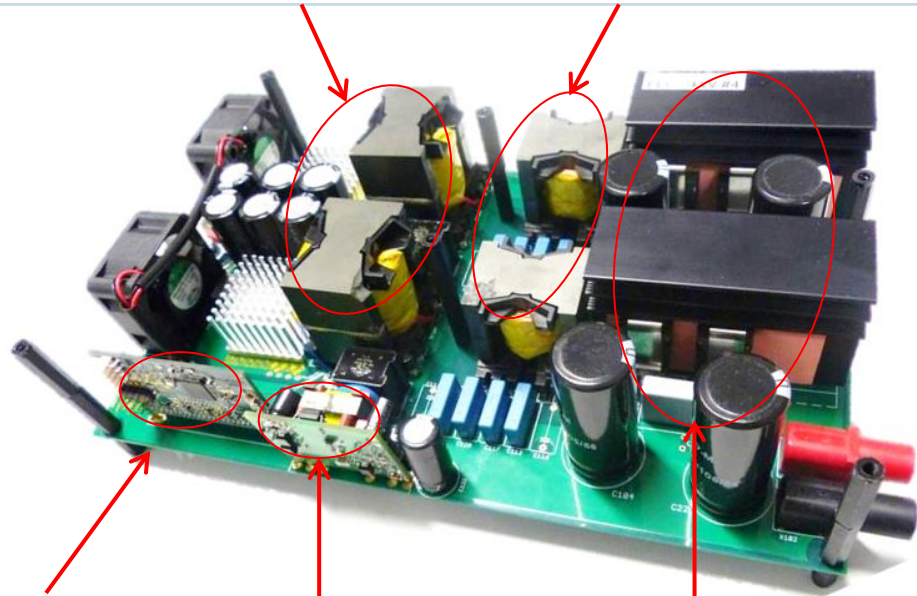

**LLC controller**  
Digital **XMC4400**

**Bias QR Flyback controller**  
**ICE2QR2280Z**

**HV MOSFETs**  
**IPW60R037P7 TO-247**

# Control Board Digital

## Infineon`s solution to control the 3kW dual phase LLC Evaluation Board

### Digital

#### [XMC4400-F64K512 AB](#)

##### Summary of Features:

- › ARM® Cortex™-M4, 120MHz, incl. single cycle DSP MAC and floating point unit (FPU)
- › 8-channel DMA + dedicated DMAs for USB and Ethernet
- › USB 2.0 full-speed on-the-go
- › CPU Frequency: 120MHz
- › eFlash: 512kB including hardware ECC
- › 80kB SRAM
- › Package: PG-LQFP-64

##### Target Applications:

- Motor control
- › Position detection
- › IO devices
- › HMI
- › Solar inverters
- › SMPS
- › Sense & control systems
- › PLC
- › UPS
- › Light networks

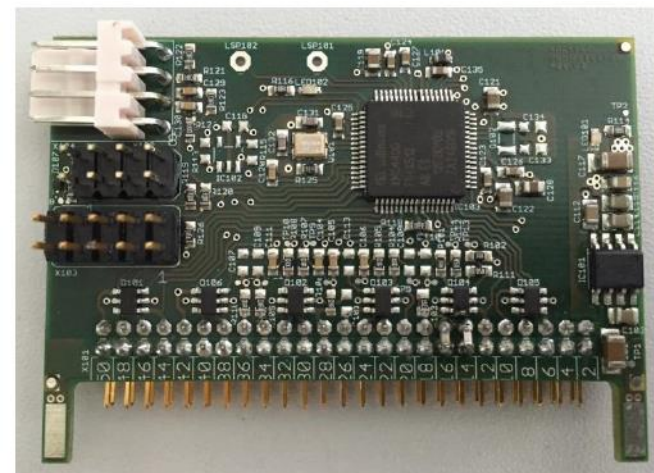



# Main Power Board Schematic\_2

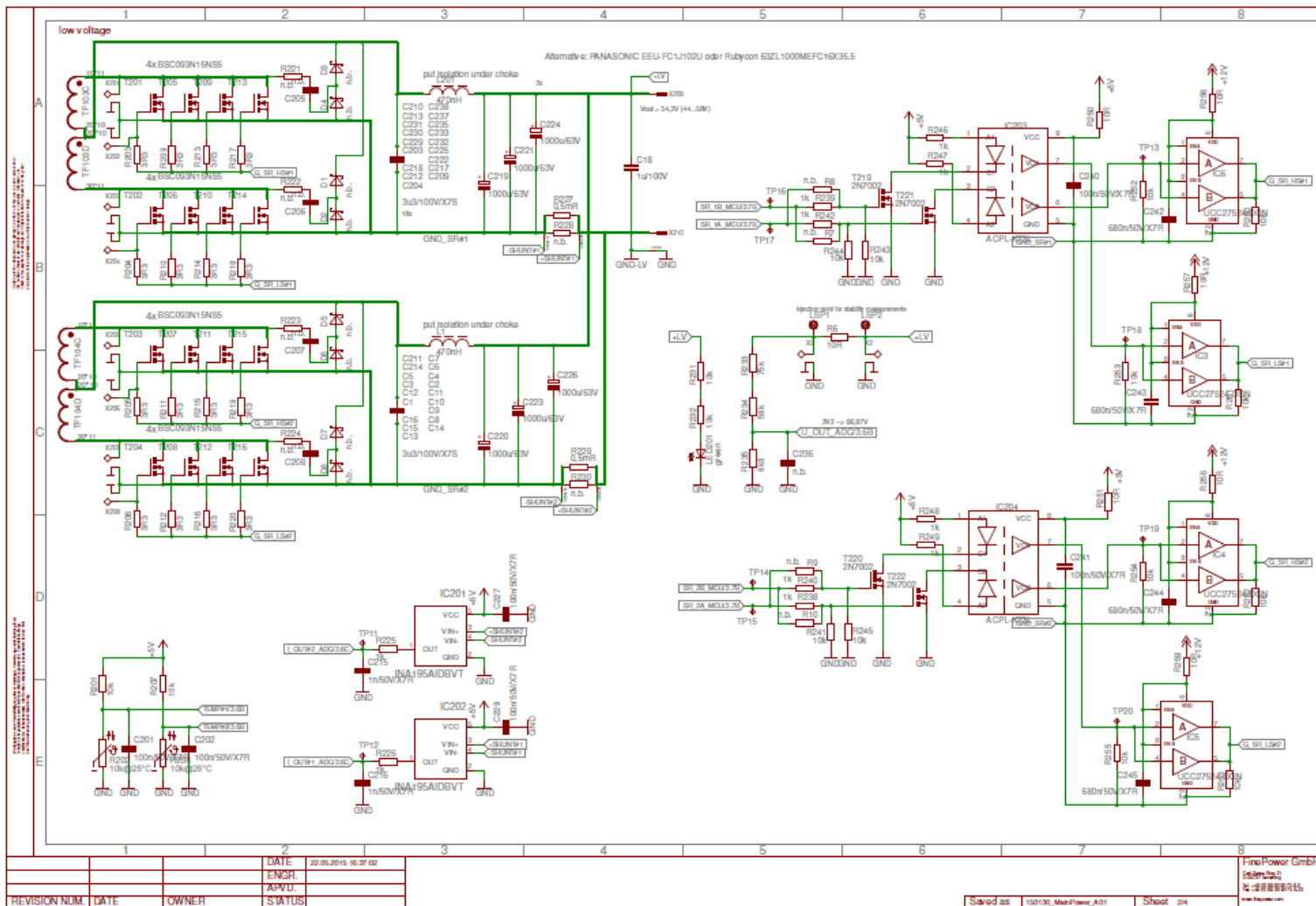



# Digital Control Board Schematic

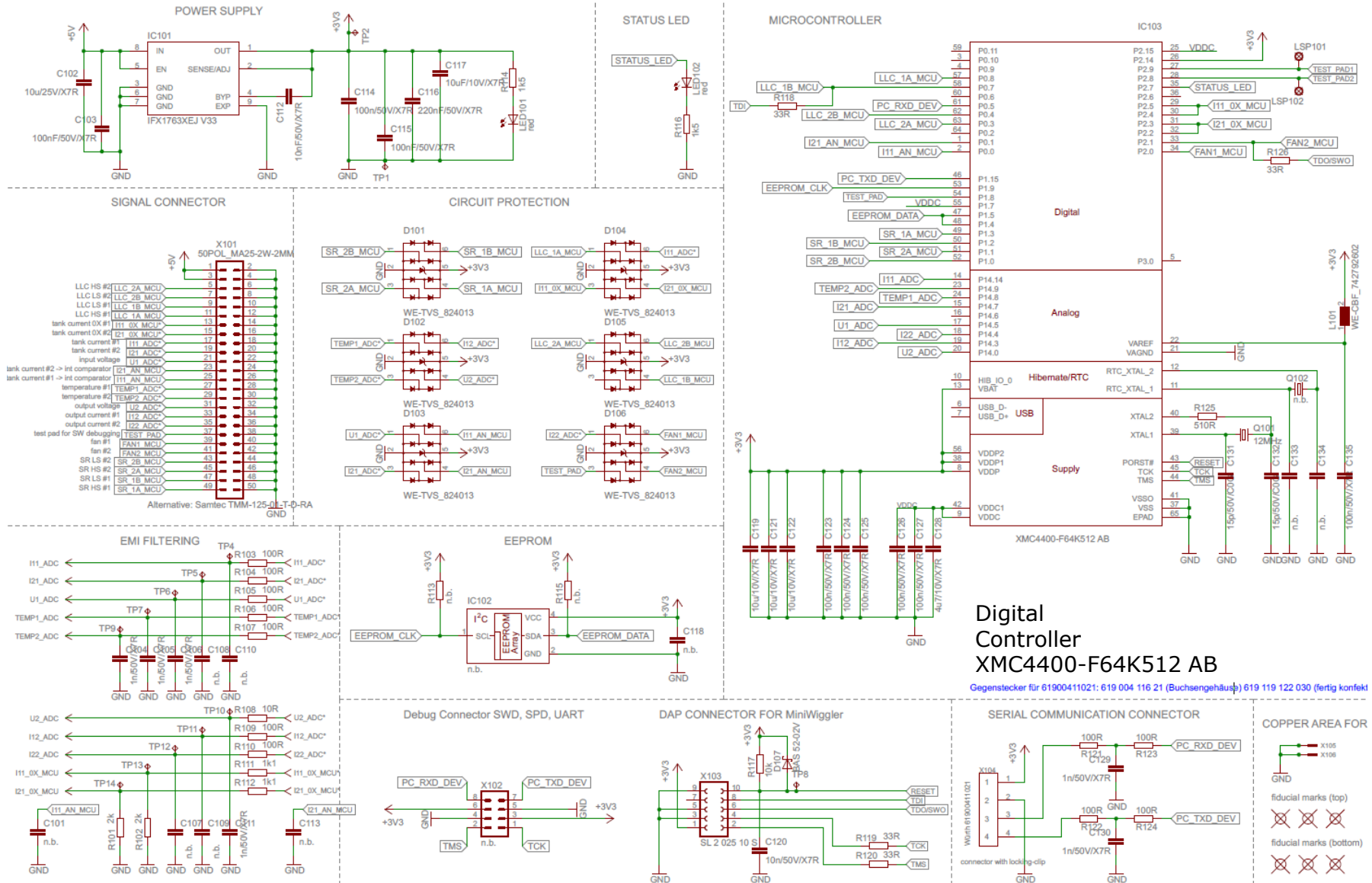

## Digital Controller XMC4400-F64K512 AB

Gegenstecker für 61900411021: 619 004 116 21 (Buchsengehäuse) 619 119 122 030 (fertig konfekt)

# Bias Board Schematic

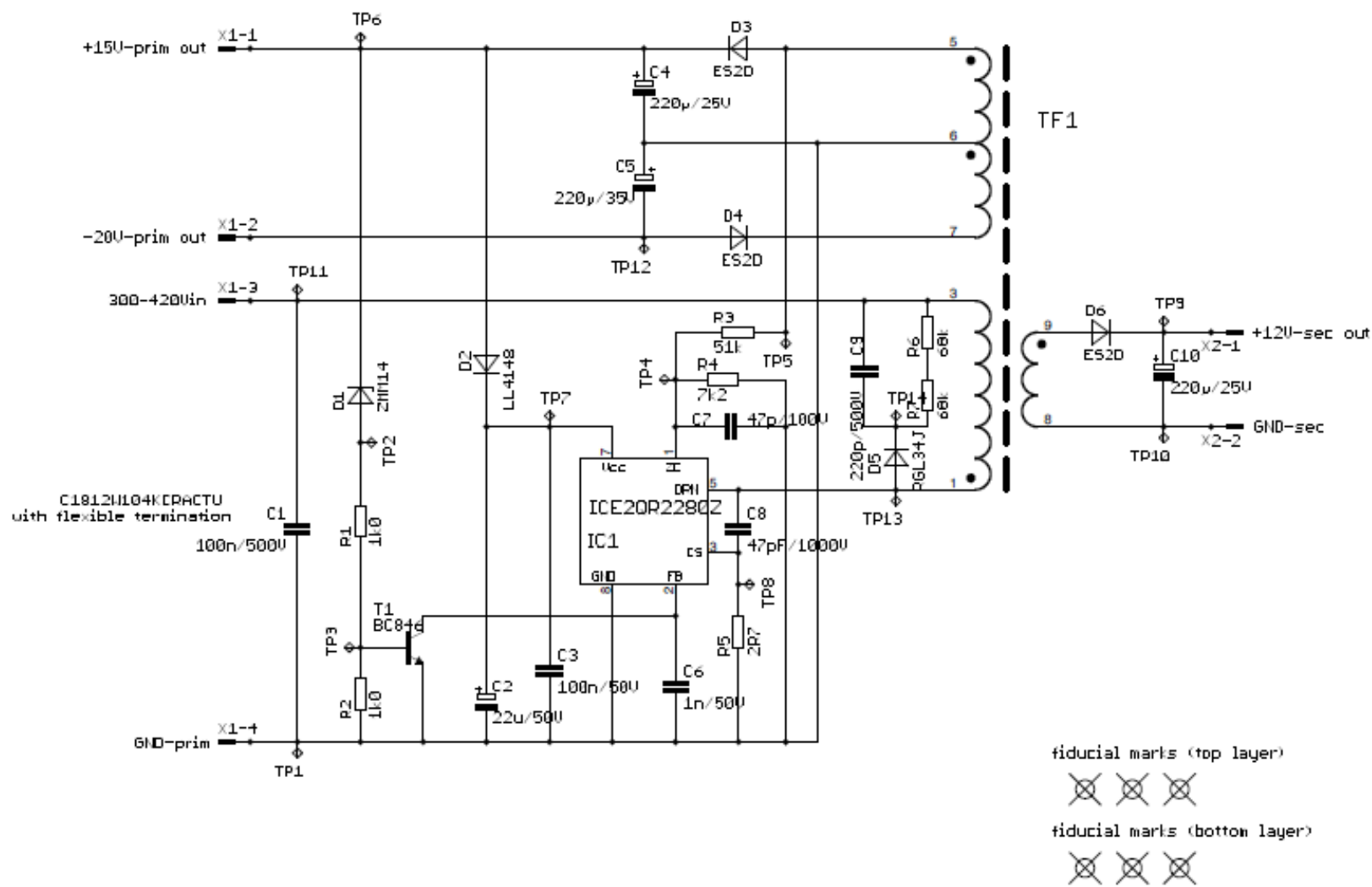

# Connection instruction



# Table of Contents

1 General Description

2 Efficiency Results

3 Design Concept

# Automated Efficiency Measurement

Combination of converter design (resonant tank, transformer) and proper HV device election

Proper selection of SR LV device and secondary side design

## 3kW Dual Phase LLC Efficiency

(without Bias & fans absorption)

Efficiency

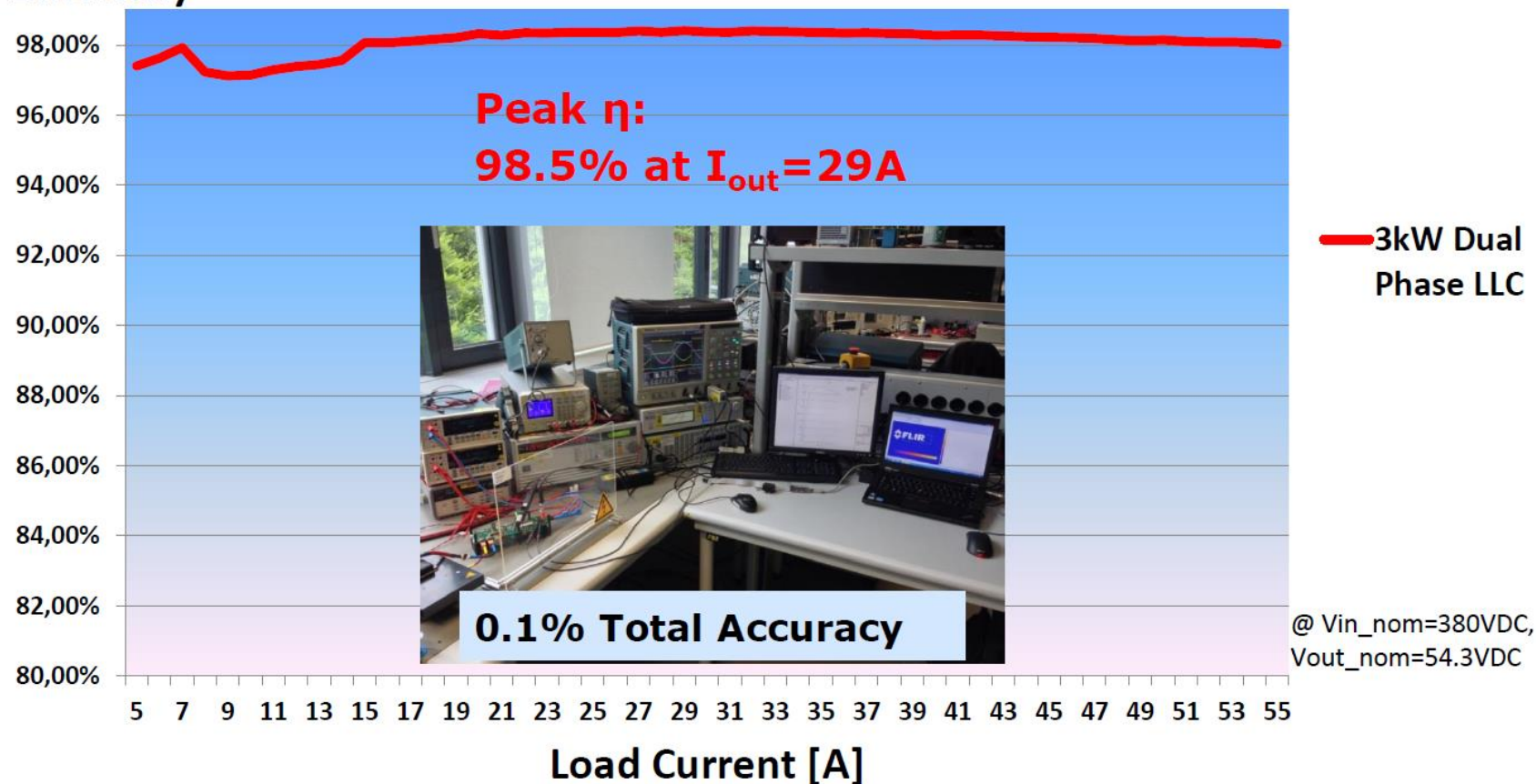

# Table of Contents

1

General Description

2

Efficiency Results

3

Design Concept

# Design Concept

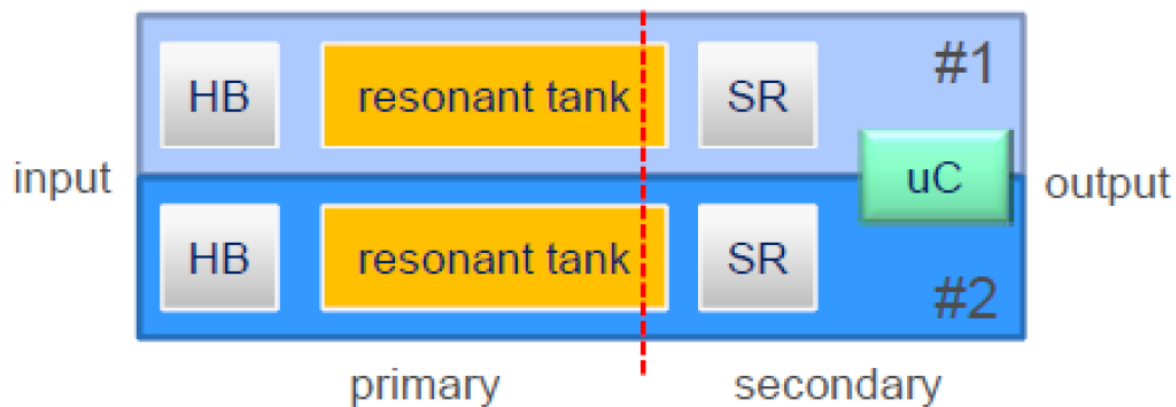

# Two Daughter Boards

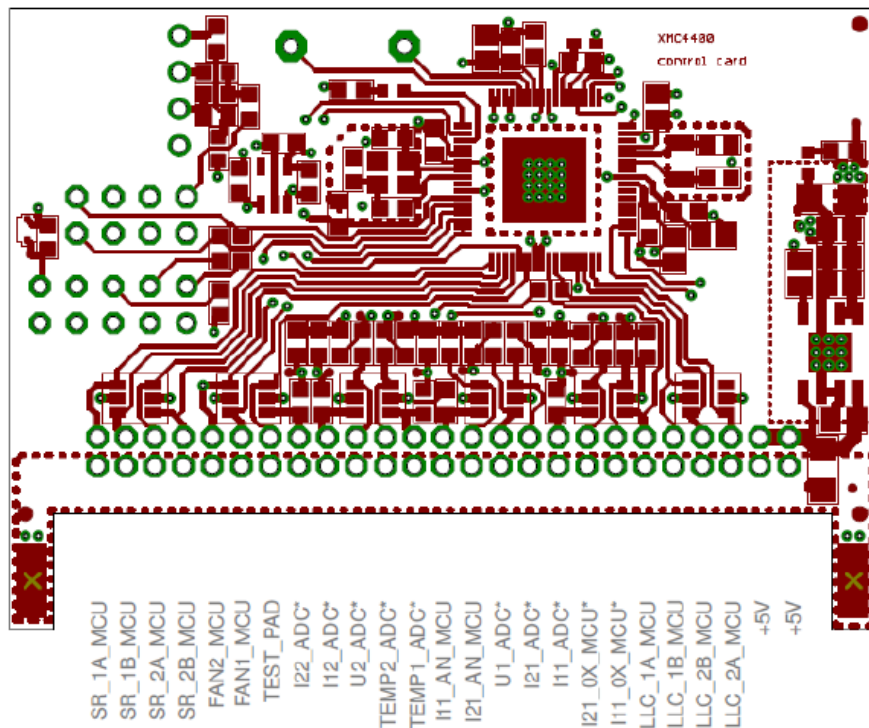

**Microcontroller Board**

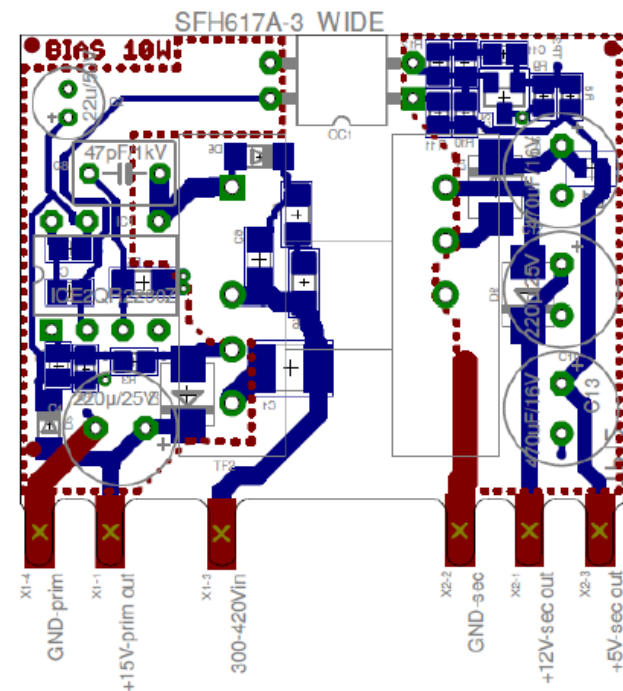

**Auxiliary Converter Board**



# Evaluation Board EVAL\_3KW\_2LLC\_P7\_47

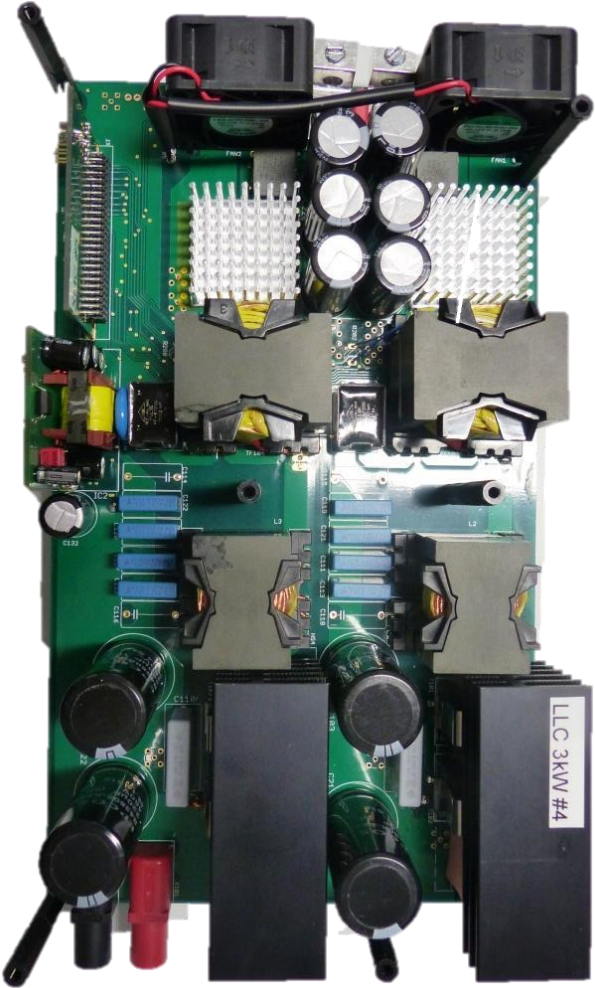
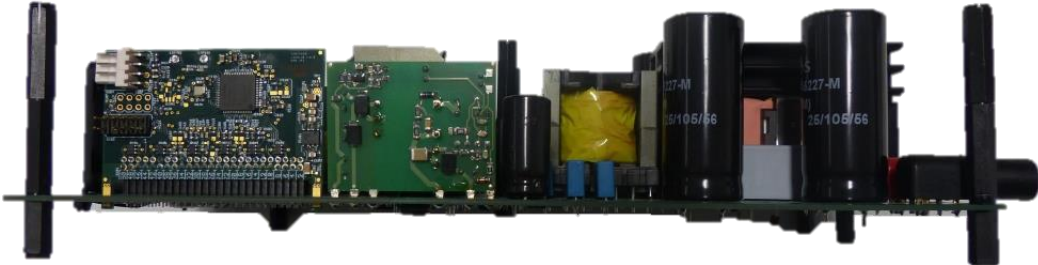

# Support Slides

## 3KW Dual LLC Evaluation Board



### Evaluation Board Page

- Technical Description
- Datasheets
- Parameters
- Related material
- Videos

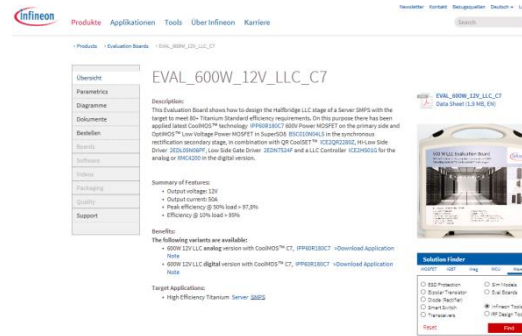

- EVAL\_3KW\_2LLC\_P7\_47

### Product Family Pages

- Product Brief
- Application Notes
- Selection Guides
- Datasheets and Portfolio
- Videos
- Simulation Models



- IPP60R037P7
- BSC093N15NS5
- XMC4400-F64K512 AB
- 2EDN7524R
- ICE2QR2280Z
- 1EDI60N12AF
- IFX1763XEJ V50
- IFX1763XEJ V33



Part of your life. Part of tomorrow.



单击下面可查看定价，库存，交付和生命周期等信息

[>>Infineon\(英飞凌\)](#)