

TLE9855QX Evaluation Kit User Manual

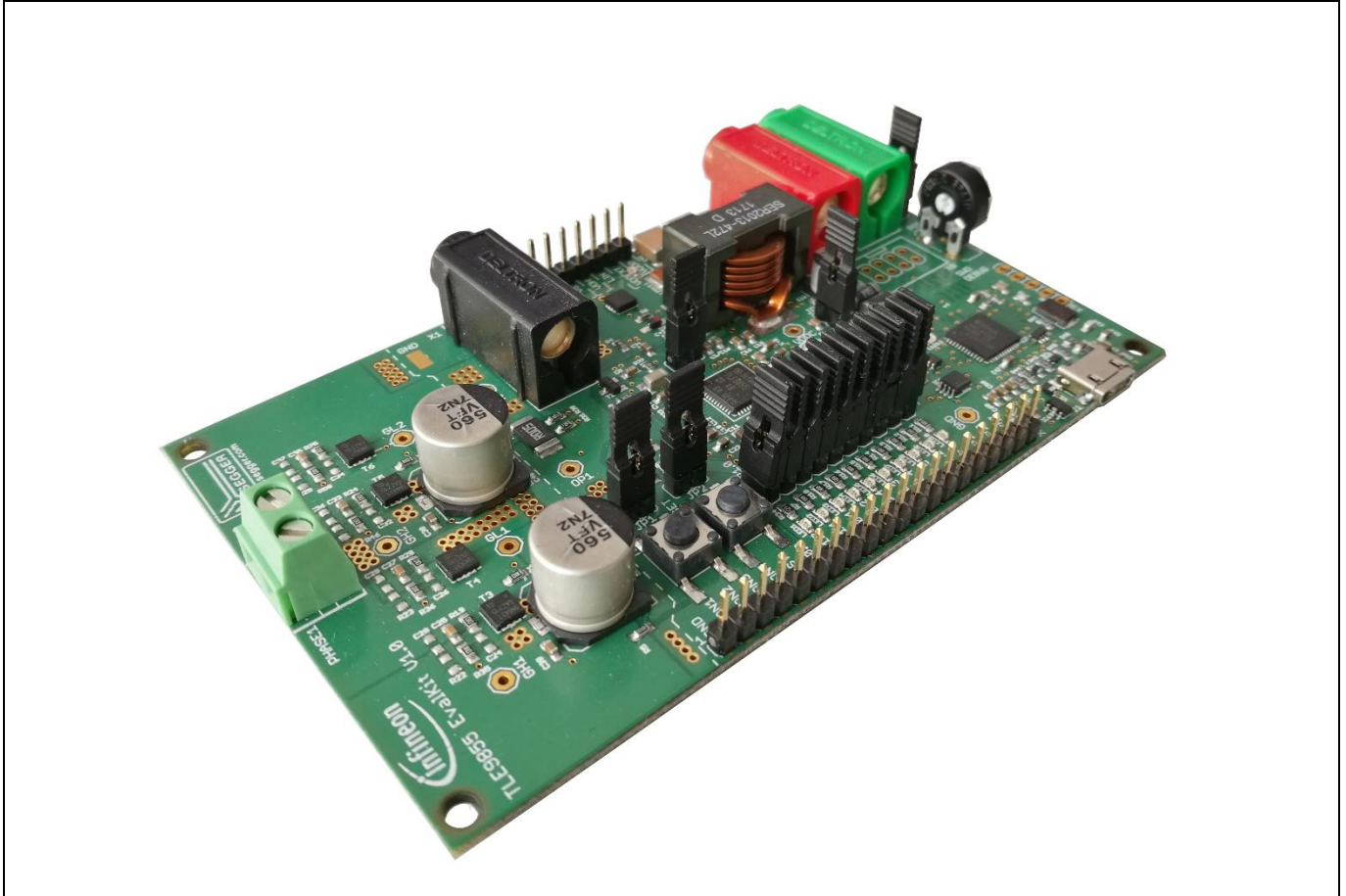

Figure 1 TLE9855QX Evaluation Kit

Table of Contents

Table of Contents	2
1 Concept	3
2 Interconnects	4
3 Test Points	6
4 Jumper Settings	7
5 Communication Interfaces	9
5.1 LIN (via banana jack an uIO BSL)	9
5.2 UART (via USB).....	9
5.3 Debugging (via USB or SWD Interface)	9
6 Technical Data	11
7 Optional Additional Placements	12
8 Schematics and Layout	13
8.1 Schematics	13
8.2 Layout	17
9 Revision History	19
Abbreviations	20

1 Concept

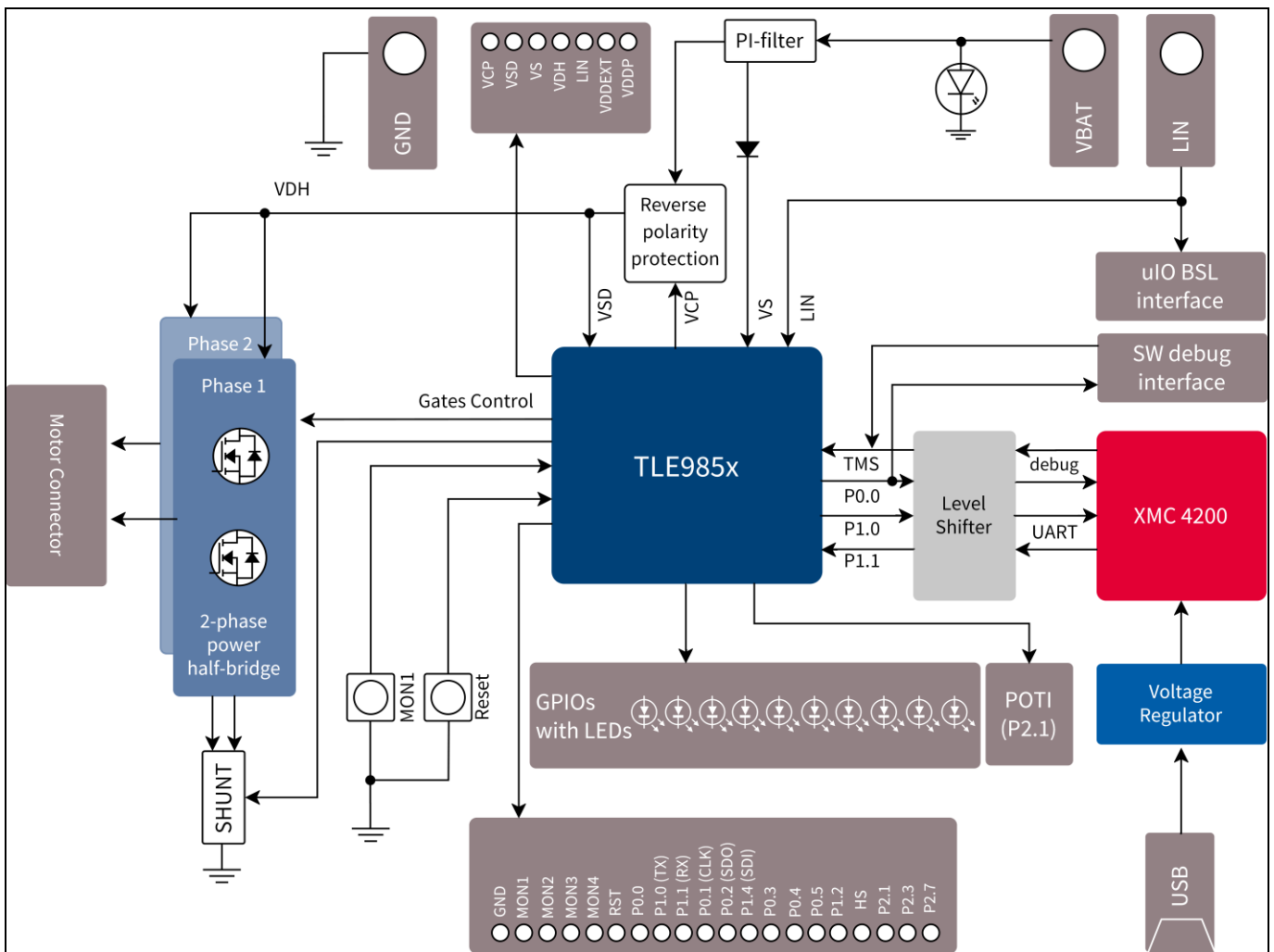

Figure 2 Board Concept

This board is intended to provide a simple, easy-to-use tool for getting familiar with Infineon’s Embedded Power H-Bridge driver IC. It contains the TLE9855QX and its typical application circuit. This includes two MOSFET half bridges to drive a DC motor.

The MOSFET halfbridges have a screw terminal to directly connect a DC motor to the Evalkit.

GPIOs and MON PINs are accessible through pin headers at the edge of the board. Two push buttons trigger a PIN reset or a MON1-Input. A Potentiometer is connected to one ADC input.

The evaluation board can be supplied via 4mm banana jacks. An on-board Segger J-Link (XMC4200) provides a SWD interface and a virtual COM port, which can be used for serial communication with the board.

A battery LED indicates power supply connection. Typically, the board is supplied by 12V. An applied reverse polarity protection circuit secures the board from damage.

2 Interconnects

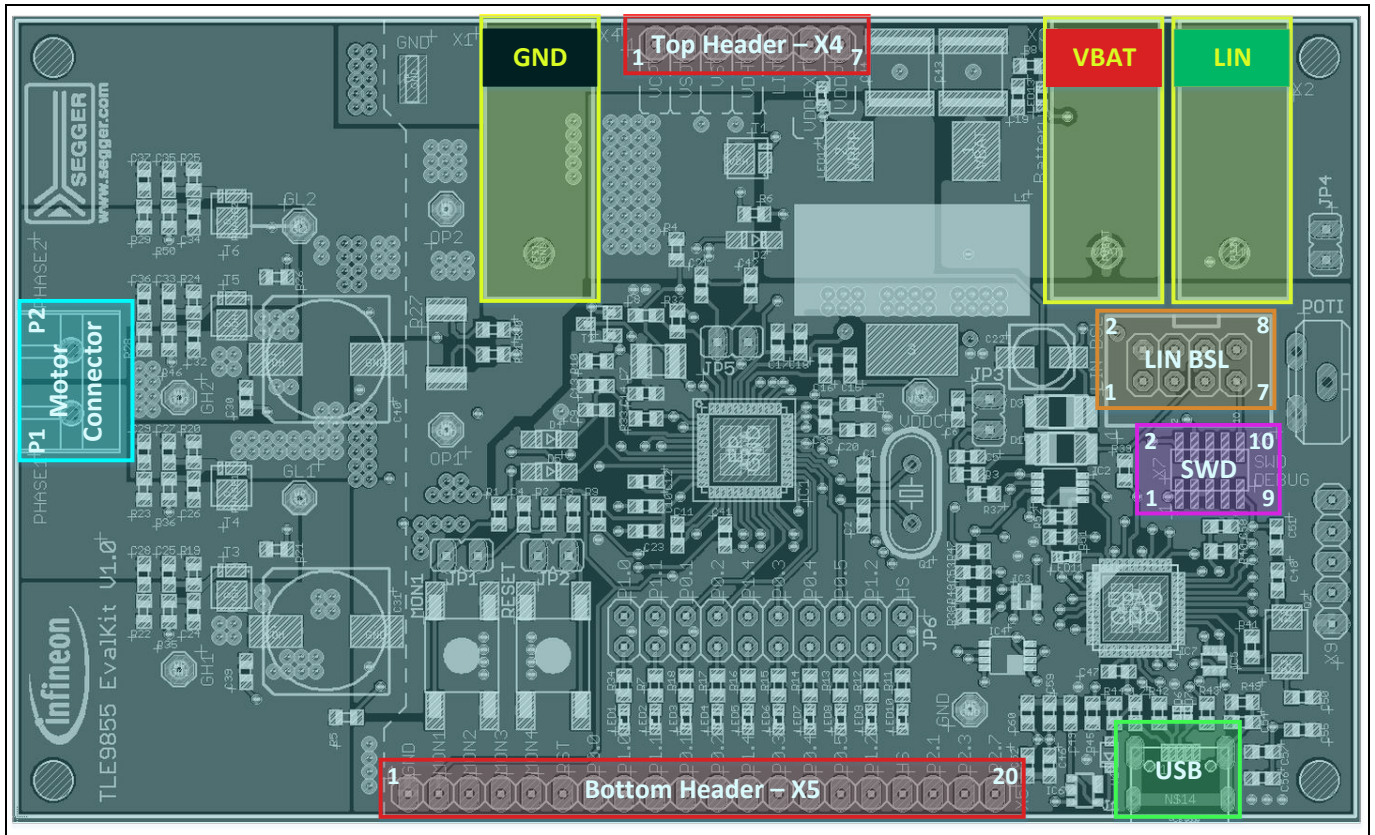

Figure 3 Interconnects

Banana jacks (marked yellow)

The jacks have different colors for GND (black), VBAT (red) and LIN (green).

Top Pin Header X4 and Bottom Pin Header X5 (marked red)

Soldering pin headers with 2,54mm pitch for X4 (1x7) and X5(1x20) yields test points for the TLE9855QX pins. Following signals are connected to the pins:

Table 1 Top Pin Header X4 Pinout

1	2	3	4	5	6	7
VCP	VSD	VS	VDH	LIN	VDDEXT	VDDP

Table 2 Bottom Pin Header X5 Pinout

1	2	3	4	5	6	7	8	9	10
GND	MON1	MON2	MON3	MON4	RST	P0.0	P1.0 (TX)	P1.1 (RX)	P0.1 (CLK)
11	12	13	14	15	16	17	18	19	20
P0.2 (SDO)	P1.4 (SDI)	P0.3	P0.4	P0.5	P1.2	HS	P2.1	P2.3	P2.7

Terminal block for connecting the motor (marked cyan)

The two pins of the terminal block provide access to the two half bridges and are intended to connect a DC motor.

USB for UART and Debugging (marked green)

With this Micro USB PC and evaluation board can get connected.

uIO BSL Pin Header X8 for LIN (marked orange)

This uIO bootstrap loader is an 8 pin header (2x4) with 2,54mm pitch. It is intended to connect additional hardware for bootstrap loading. For programming the TLE9855QX via LIN this uIO interface can be used (see www.infineon.com/cms/en/product/evaluation-boards/uio-stick/).

Table 3 uIO Pin Header X8 Pinout

n.c.	1	2	GND
n.c.	3	4	n.c.
LIN	5	6	VS
RESET	7	8	n.c.

Software Debug (SWD) SMD Pin Header X7 (marked purple)

There is a 10 pin SMD header (2x5) with 1,27mm pitch on the Evaluation Kit. For debugging with another ISP than the on board Segger this interface can be used. DBPRE will be implicitly connected to GND by connecting the external ISP. This keeps the XMC4200 in reset state to prevent interferences of the SWD communication.

Table 4 SWD Pin Header X7 Pinout

5V	1	2	SWDIO (TMS)
GND	3	4	SWCLK (P0.0)
GND	5	6	n.c.
n.c.	7	8	n.c.
DBPRE	9	10	RESET

3 Test Points

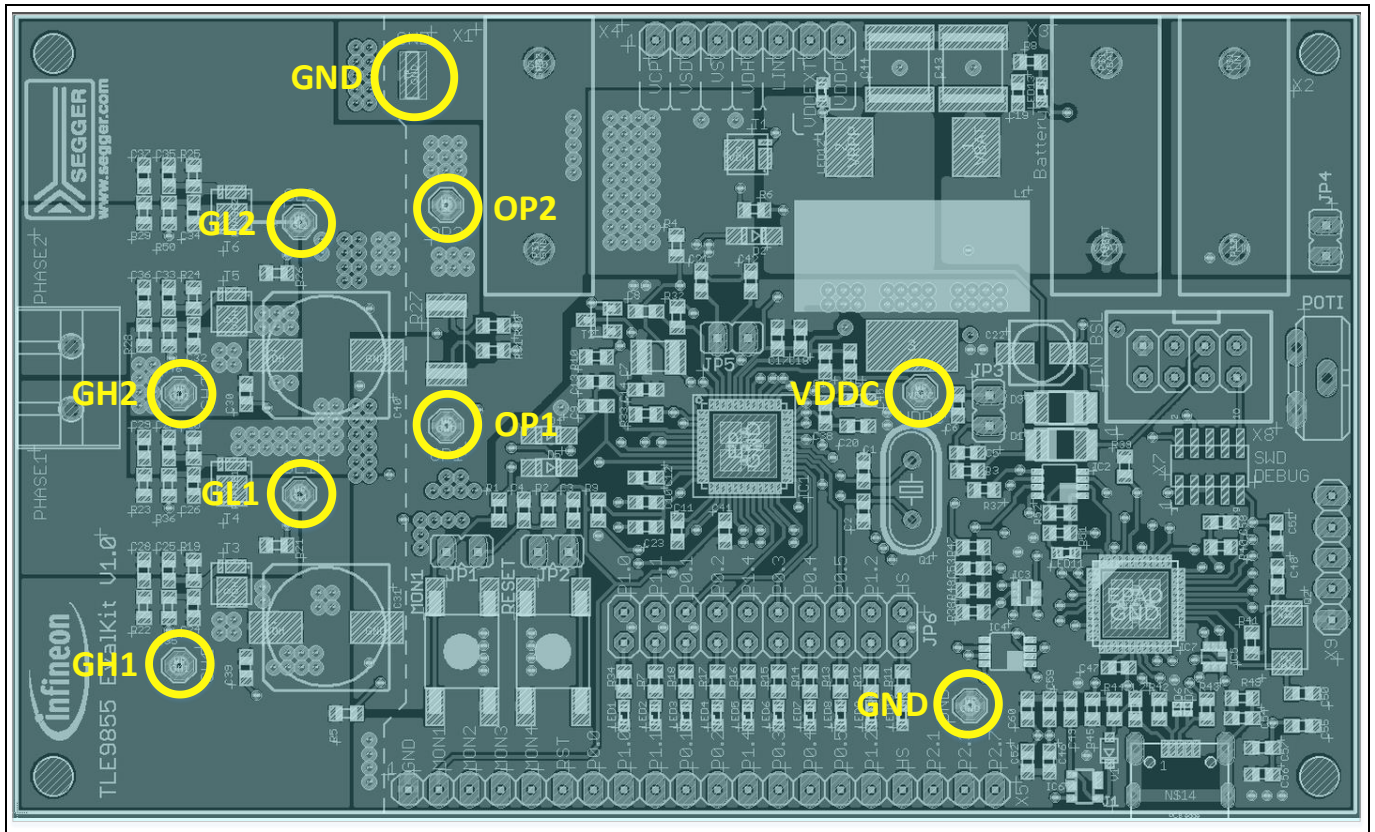

Figure 4 Test Points

The 2-phase power half-bridge is controlled by four gate driver pins, driving the gates of High side MOSFET and Low side MOSFET for each phase. Each gate has an intended test point to measure the respective signals at High side gates and Low side gates (GL1, GL2, GH1, GH2).

Test points OP1 and OP2 are provided at both sides of the shunt, which is 5mR.

Additionally there is an intended test point for VDDC and various ground points.

All test points marked in figure 4 except the SMD GND point at the top are not populated. In order to use these pins they have to be soldered in the designated solder holes.

4 Jumper Settings

The following table summarizes the jumpers' options. More detailed information can be found in the text below.

Table 5 Jumpers' functionalities

JP1	Enable or disable MON1 button
JP2	Enable or disable RESET button
JP3	Select TLE9855QX as LIN Master or LIN Slave
JP4	Enable or disable POT1
JP5	Replace by an ampere meter to measure input current
JP6	Enable or disable LED for respective GPIO

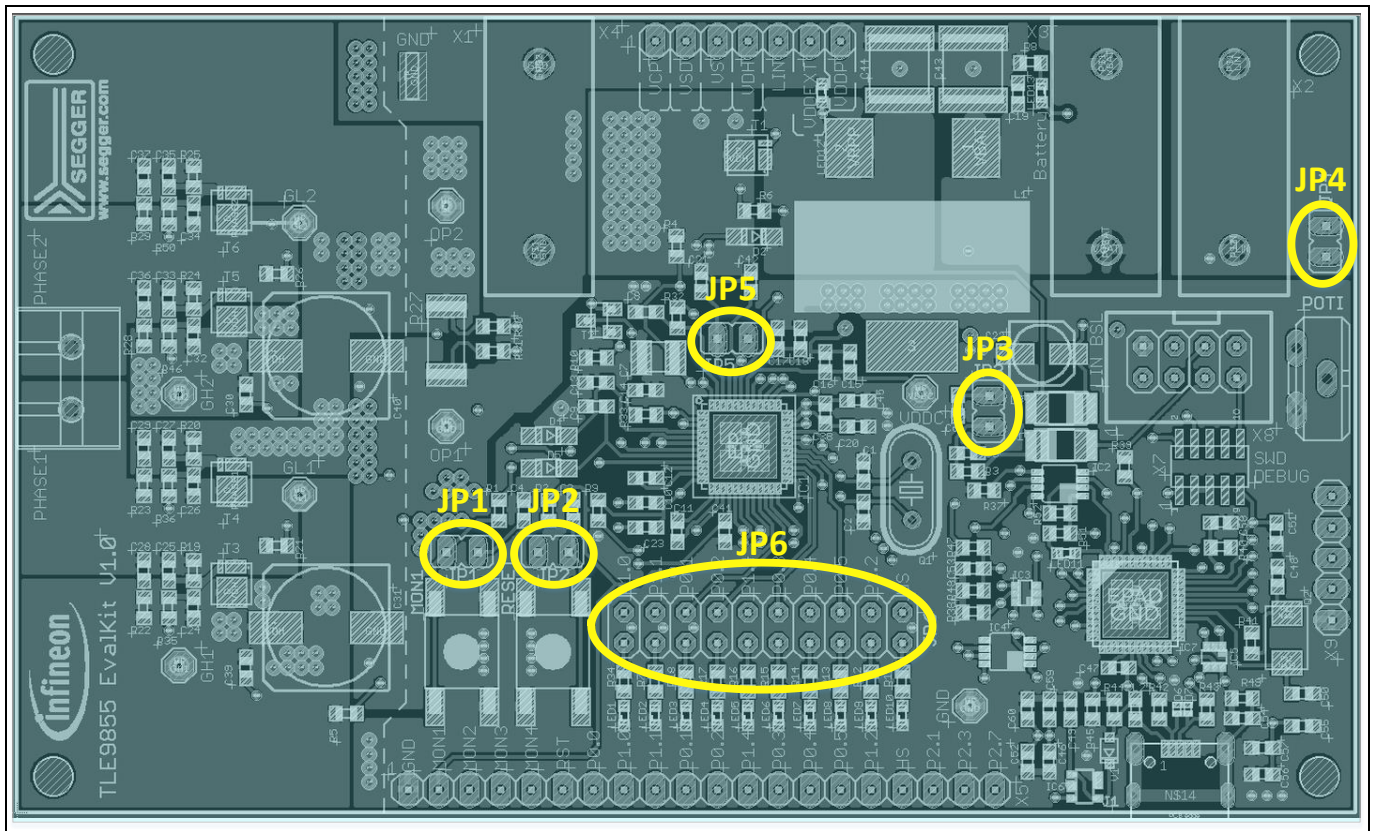

Figure 5 Jumpers

JP1: Close this jumper to connect MON1 button to MON1 input. Open it to disconnect MON1 button from MON1 input.

JP2: Close this jumper to connect RESET button to RESET input. Open it to disconnect RESET button from RESET input.

JP3: Close this jumper to connect an additional 1k pull-up resistor. This is intended for LIN master communication. Open the jumper to use the TLE9855QX as slave in a LIN network. Software for LIN low level driver can be found at on the [IHR website](#).

JP4: Close this jumper to connect the 10k potentiometer to P2.1. Open this jumper to disconnect the potentiometer.

JP5: This jumper is closed by default. If this jumper is left open the device is not supplied. It is intended to open the VS line in order to measure the current flowing into the TLE9855QX.

JP6: Jumper 6 provides one individual jumper per LED in order to connect or disconnect the respective LED to the pin port.

Table 6 Combinations of GPIOs and LEDs

P1.0	P1.1	P0.1	P0.2	P1.4	P0.3	P0.4	P0.5	P1.2	HS
LED1	LED2	LED3	LED4	LED5	LED6	LED7	LED8	LED9	LED10

5 Communication Interfaces

5.1 LIN (via banana jack an uIO BSL)

The device integrated LIN transceiver is connected to a banana jack and additionally to the uIO BSL interface. To integrate the device in a LIN network it is sufficient to use the single wire banana interface. The BSL interface is intended to program the device via LIN. For further information about the uIO interface see www.infineon.com/cms/en/product/evaluation-boards/uio-stick/.

5.2 UART (via USB)

A virtual COM port provided by Segger driver enables a PC – board – communication via UART. The UART2 module of TLE9855QX uses the pins P1.0 (transmit) and P1.1 (receive). Those are connected to the XMC4200, which emulates RX and TX on PC side with Segger firmware. Though they cannot be disconnected physically, bidirectional level shifters ensure that the XMC pins are hi-Z in case the virtual COM port is not used.

By connecting the evaluation board to the PC a virtual COM port gets emulated by the Segger driver automatically. The port used will show up in the Microsoft® Windows® device manager.

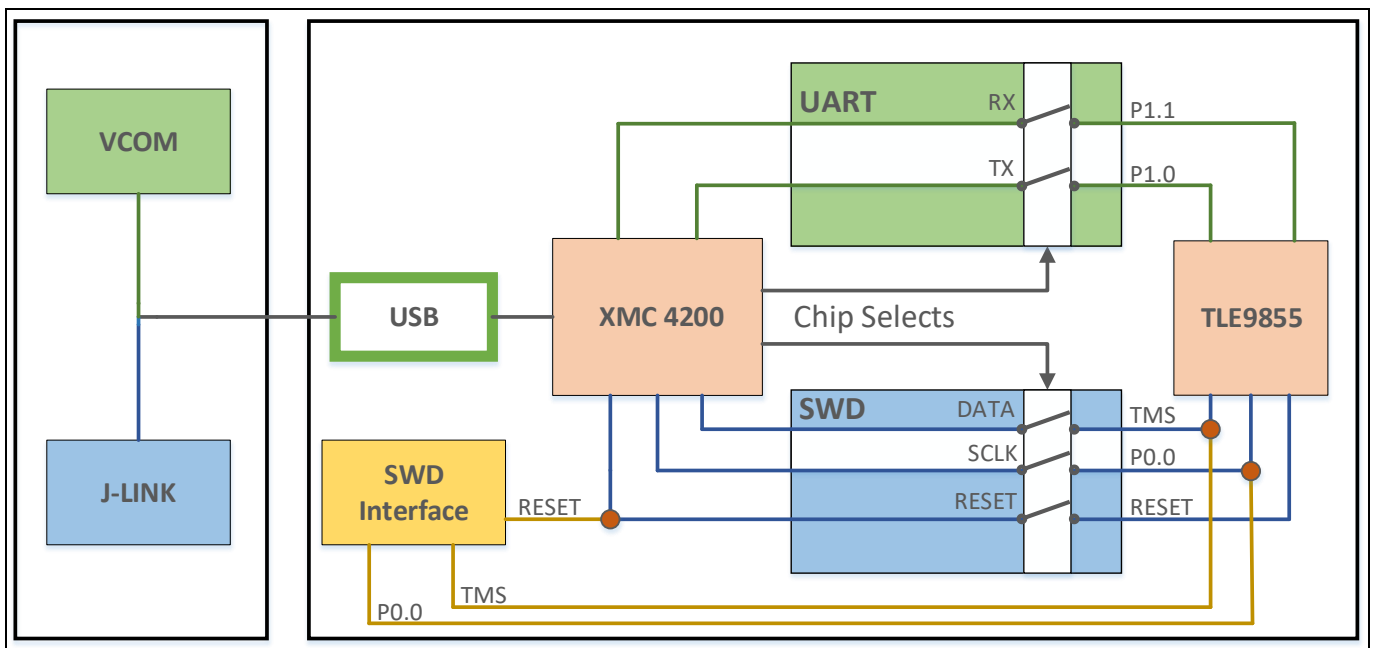

Figure 6 UART and Debugging

Note: Only one of the interfaces USB or SWD can be used at one time. While using the SWD interface the XMC is hold in reset. As long as a debugger is connected with the SWD interface it eliminates therefore debugging or UART via USB.

5.3 Debugging (via USB or SWD Interface)

For serial wire debug the TLE9855QX uses the pins TMS (data) and P0.0 (clock). Level shifters between XMC4200 and TLE9855QX allow using P0.0, while it is not used for debugging.

The Segger J-Link module on board allows serial wire debugging via USB. Alternative debugging via SWD interface is possible to debug with another ISP than the onboard Segger e.g. U-Link2. Therefore the signals are routed through the 10 pin header SWD interface between the XMC4200 and the TLE9855QX. The pin

configuration makes sure that the XMC is hold in reset while another debugger is physically connected as DBPRE will be implicitly connected to GND by connecting the external ISP (see Table 5).

Information regarding the software installation for editor, compiler and debugger can be found on Infineon website .

6 Technical Data

Platine Size: (110x66) mm

Voltage Supply: 5,5 V (min.) to 28,0 V (max.)

Motor Current: max. 10A

Pin Ports: 5V (GPIOs of TLE9855QX)

7 Optional Additional Placements

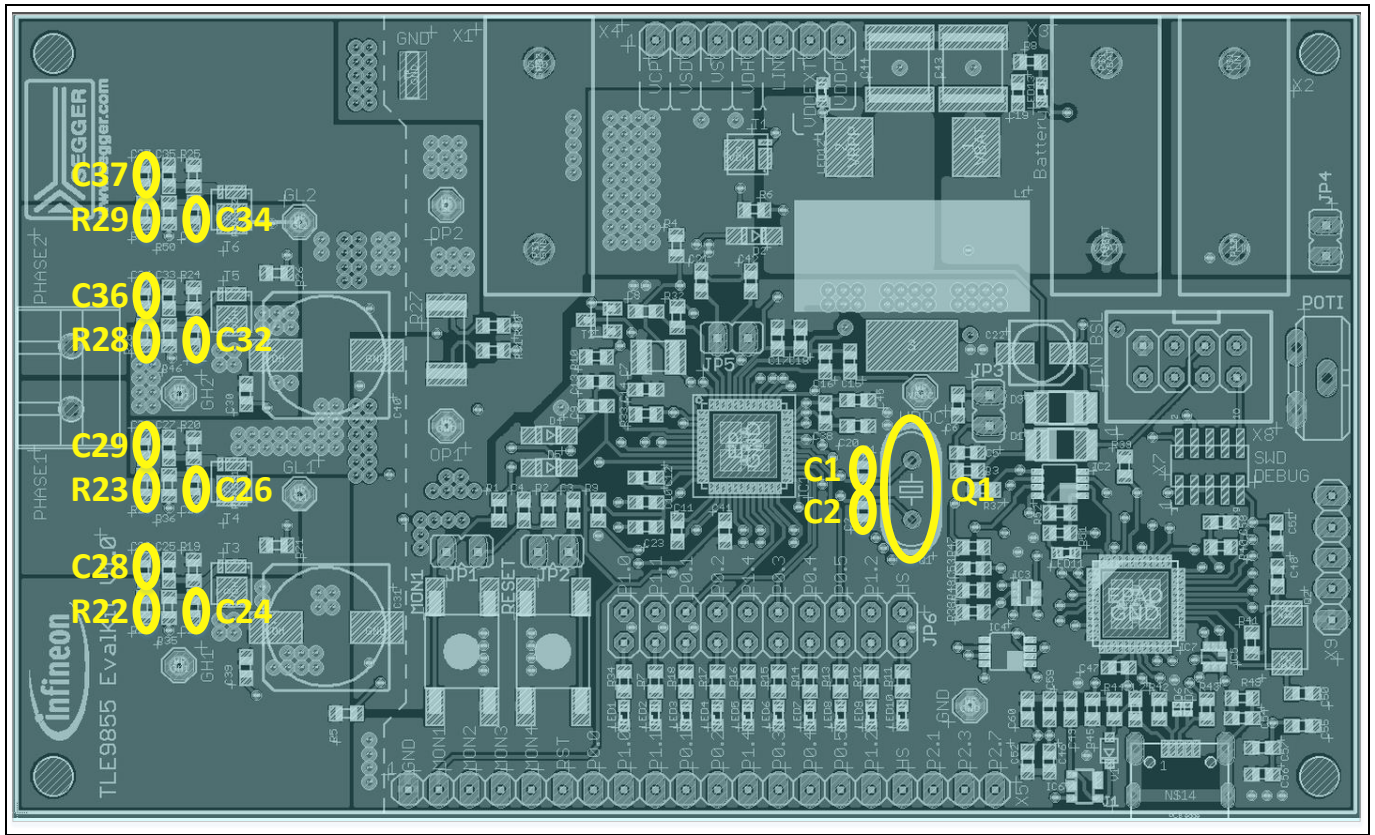

Figure 7 Additional Placements' positions

Values for these optional additional placements have to be determined depending on application.

Table 7 Additional Placements

Name	Purpose	Possible Value
Q1	External Oscillator	-
C1	Oscillator Capacity	-
C2	Oscillator Capacity	-
R22	Resistance Snubber High side MOSFET Phase 1	2 R
C28	Capacity Snubber High side MOSFET Phase 1	10 nF
C24	Gate-Drain-Capacity High side MOSFET Phase 1	33 pF
R23	Resistance Snubber Low side MOSFET Phase 1	2 R
C29	Capacity Snubber Low side MOSFET Phase 1	10 nF
C26	Gate-Drain-Capacity Low side MOSFET Phase 1	33 pF
R28	Resistance Snubber High side MOSFET Phase 2	2 R
C36	Capacity Snubber High side MOSFET Phase 2	10 nF
C32	Gate-Drain-Capacity High side MOSFET Phase 2	33 pF
R29	Resistance Snubber Low side MOSFET Phase 2	2 R
C37	Capacity Snubber Low side MOSFET Phase 2	10 nF
C34	Gate-Drain-Capacity Low side MOSFET Phase 2	33 pF

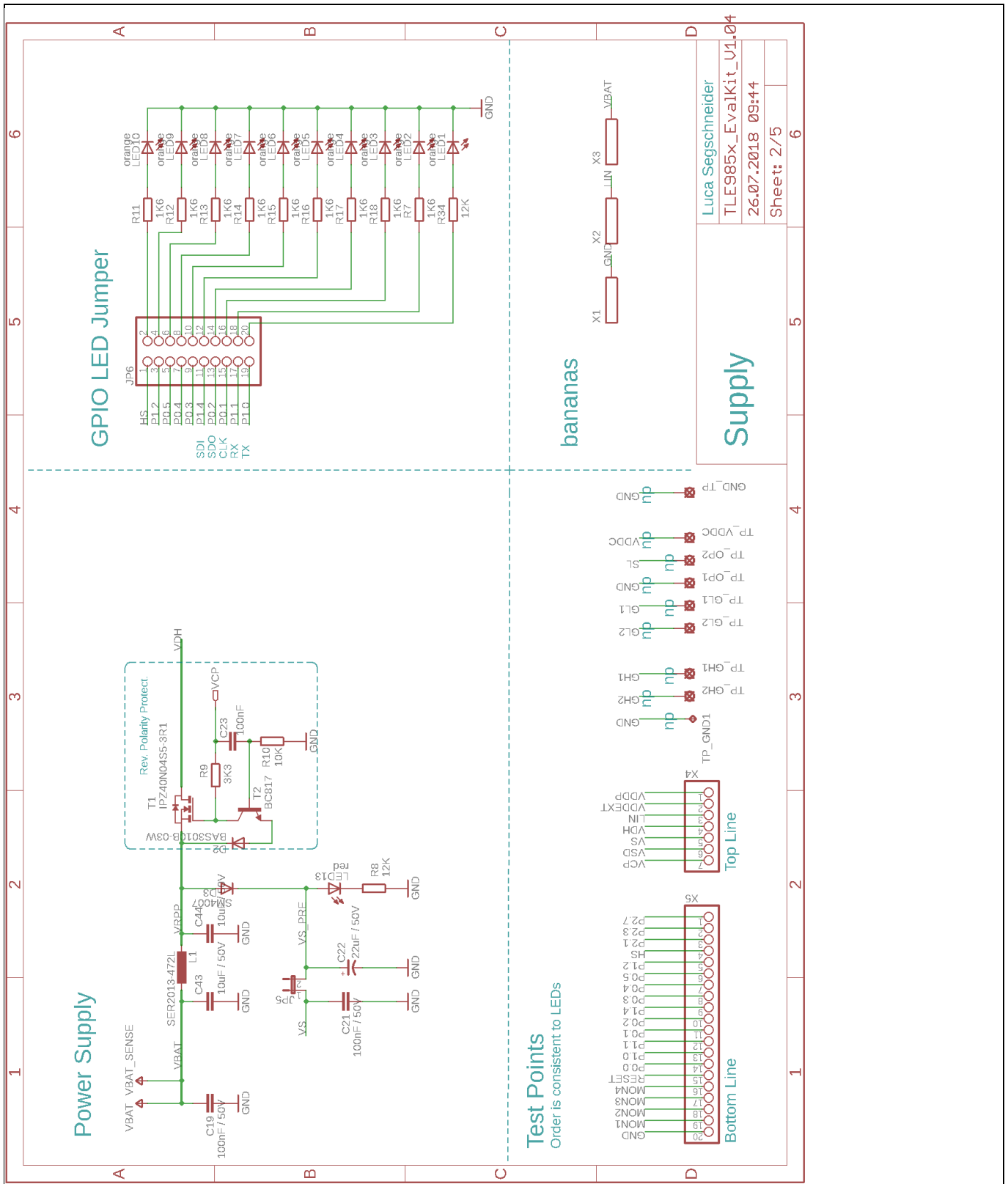

Figure 9 Schematic Sheet 2

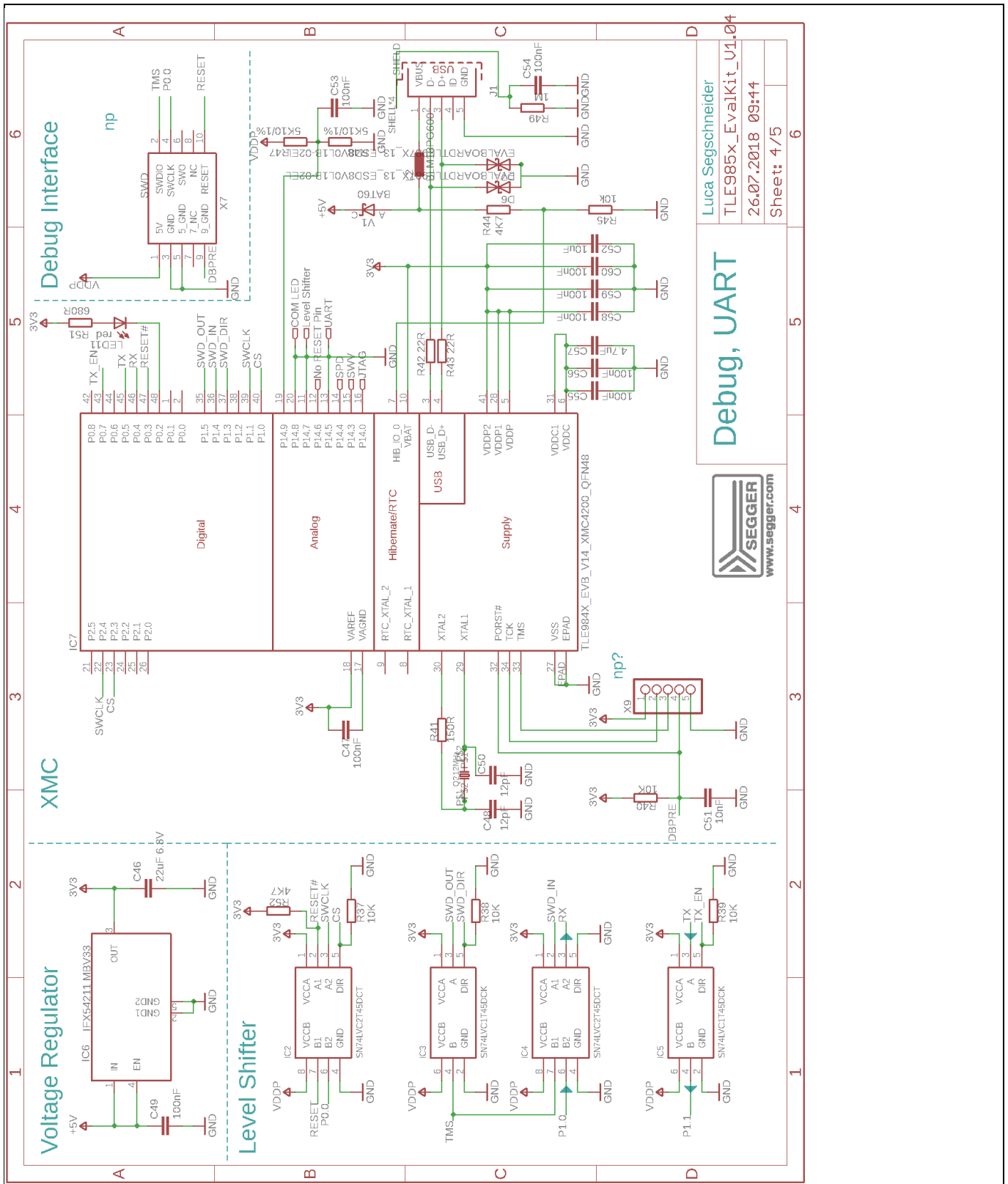

Figure 11 Schematic Sheet 4

8.2 Layout

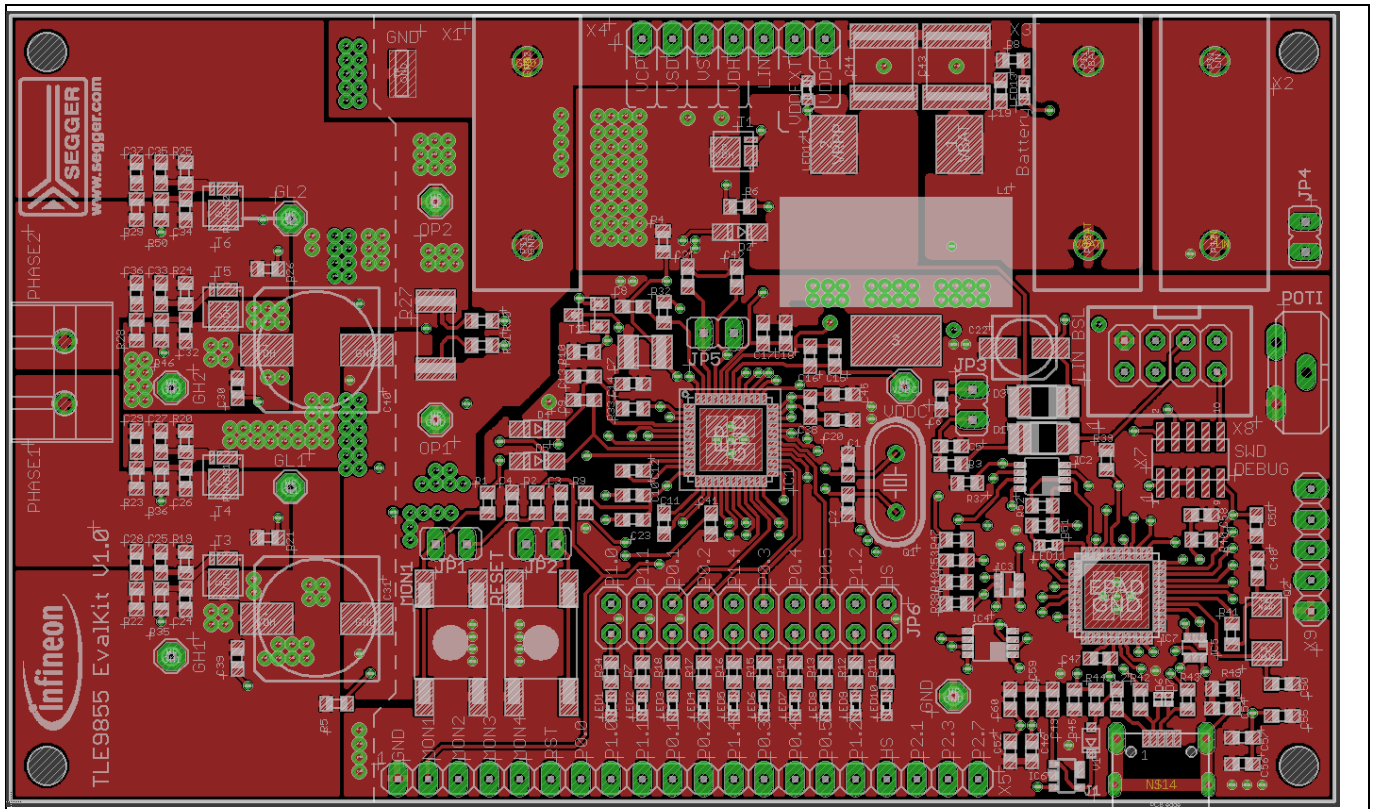

Figure 12 Layout Top Layer

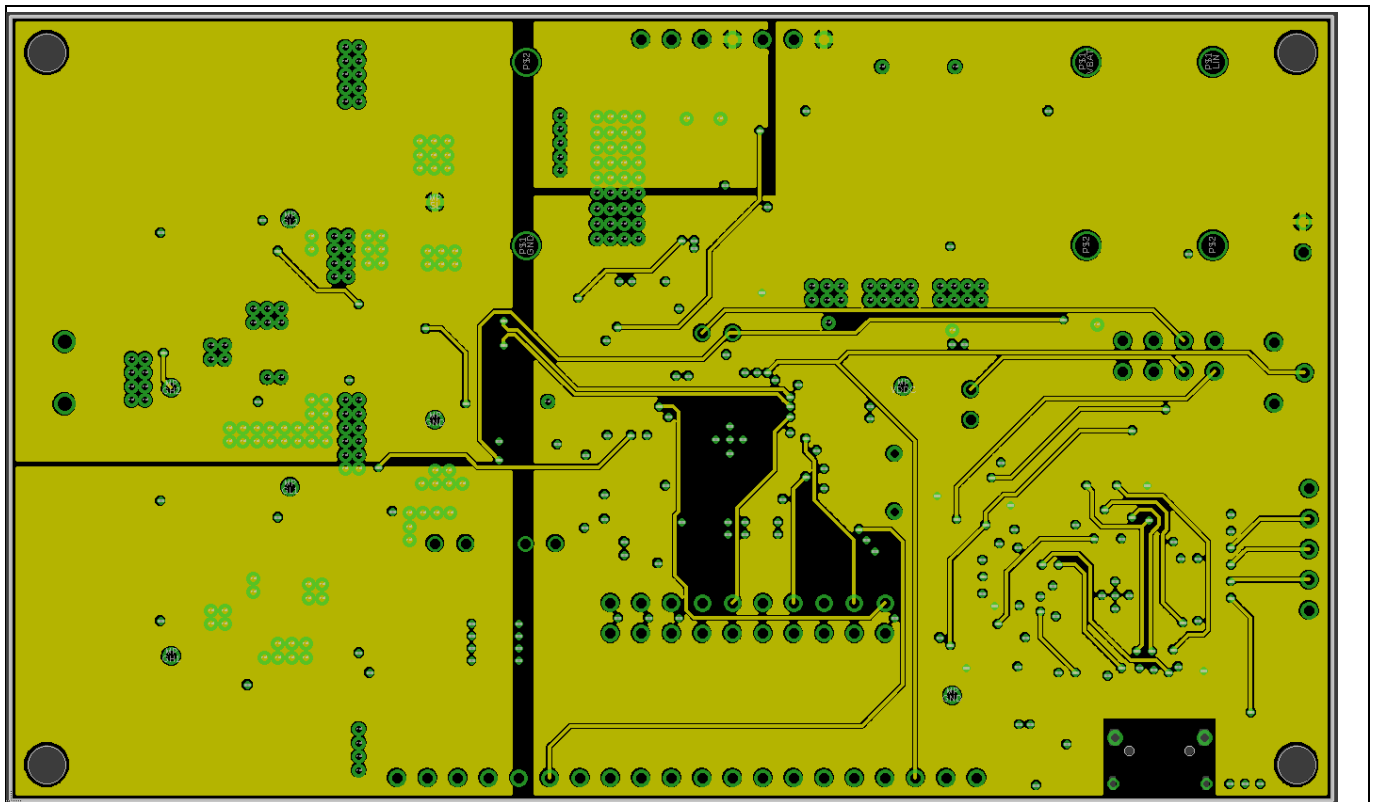

Figure 13 Layout Layer 2

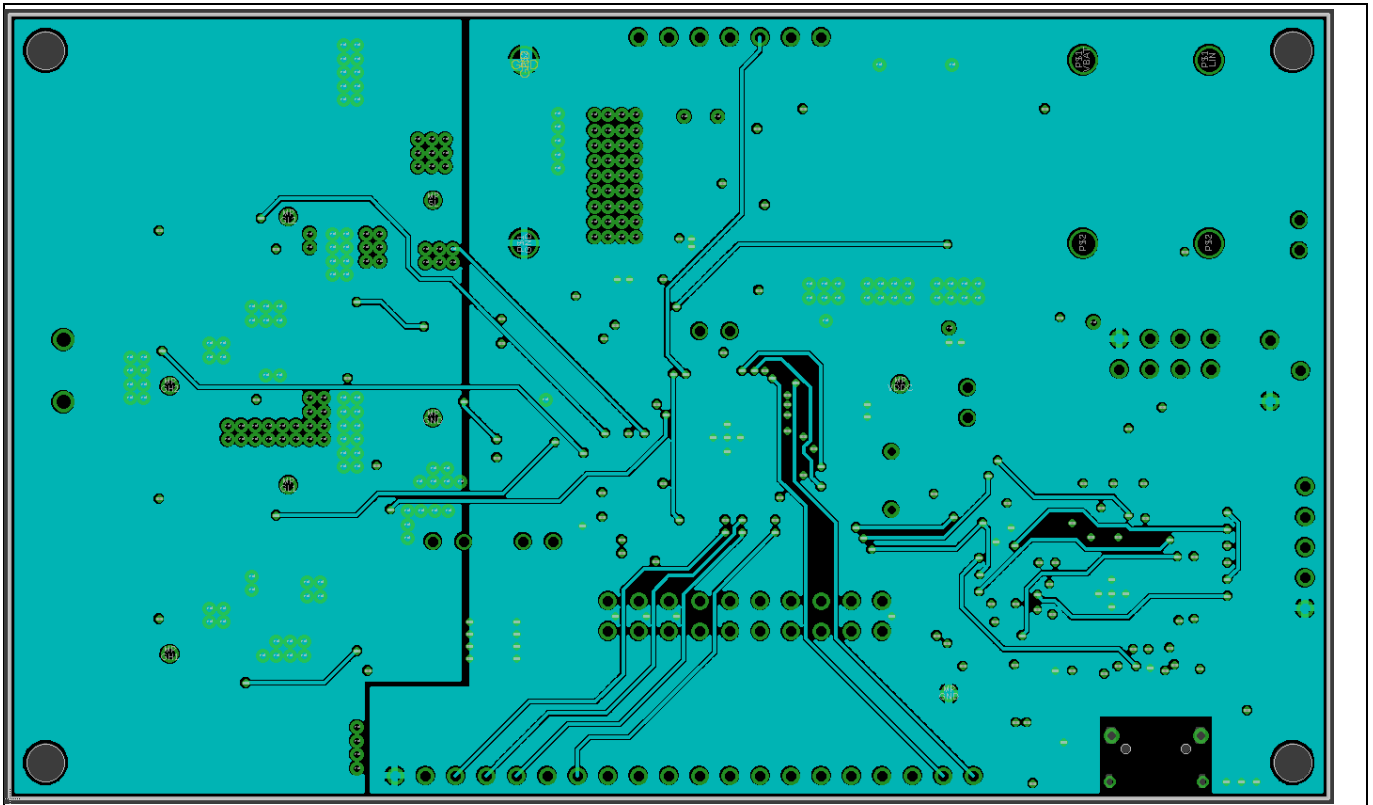

Figure 14 Layout Layer 3

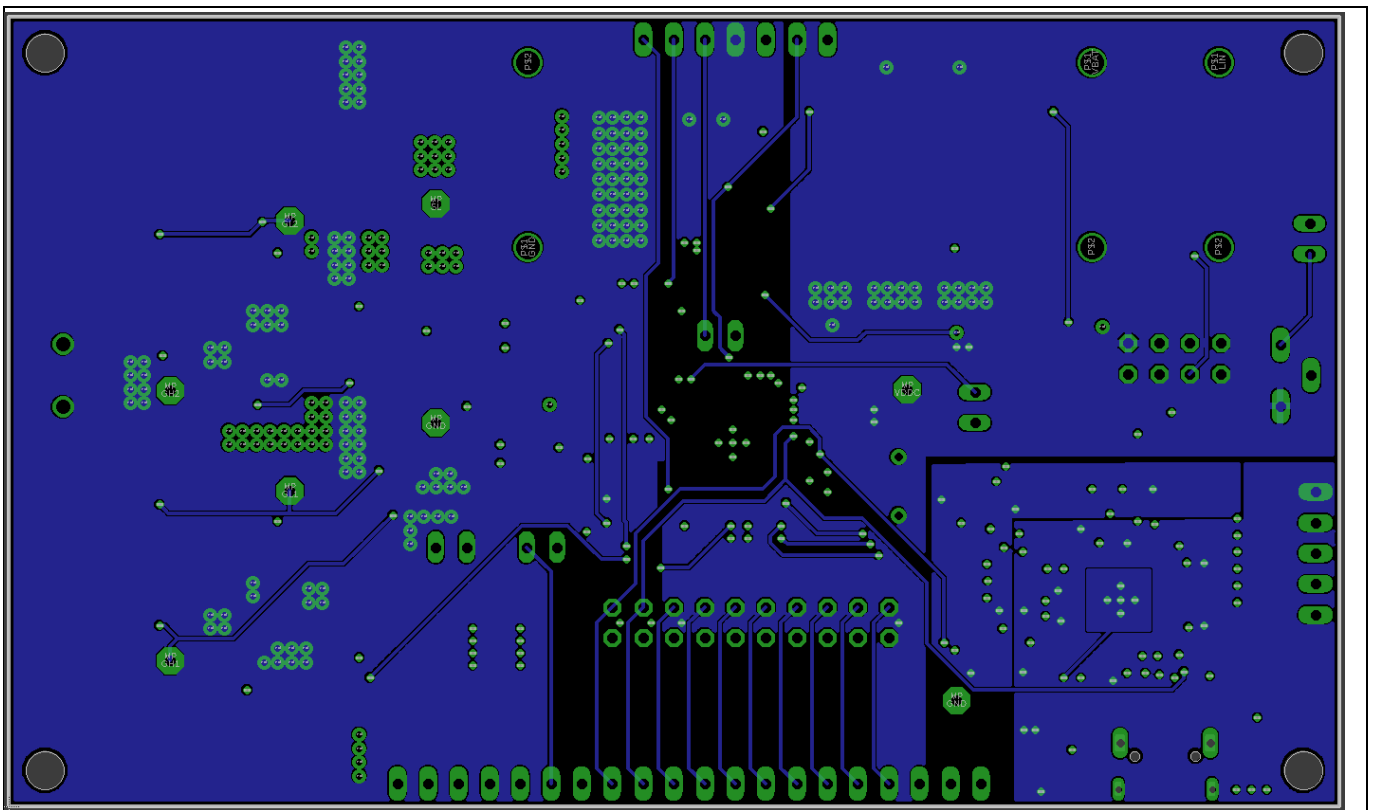

Figure 15 Layout Bottom Layer

Revision History

9 Revision History

Major changes since the last revision

Page or Reference	Description of change
Rev. 1.0	Initial Version

Revision History
Abbreviations**Table 8 Abbreviations**

BLDC	Brushless Direct Current
BSL	Bootstrap Loader
GH1,2	Gate High side MOSFET for Phases 1, 2
GL1,2	Gate Low side MOSFET for Phase 1, 2
GPIO	General Purpose Input / Output
ISP	In-System Programmer
LIN	Local Interconnect Network
MON	Monitor
n.c.	not connected
n/u	not used
OP1	Negative Operational Amplifier Input
OP2	Positive Operational Amplifier
RST	Reset
SL	Source Low side MOSFET
SMD	Surface Mounted Device
SPI	Serial Peripheral Interface
SWD	Arm® Serial Wire Debug
TMS	Test Mode Select
UART	Universal Asynchronous Receiver Transmitter
VBAT	Battery Voltage Supply
VCOM	Virtual COM-Port
VCP	Voltage Charge Pump
VDDC	Core Supply
VDDEXT	External Voltage Supply Output
VDDP	I/O Port Supply
VDH	Voltage Drain High side MOSFET
VS	Battery Supply Input
VSD	Battery Supply Input for MOSFET Driver

Trademarks of Infineon Technologies AG

AURIX™, C166™, CanPAK™, CIPOS™, CoolGaN™, CoolMOS™, CoolSET™, CoolSiC™, CORECONTROL™, CROSSAVE™, DAVE™, DI-POL™, DrBlade™, EasyPIM™, EconoBRIDGE™, EconoDUAL™, EconoPACK™, EconoPIM™, EiceDRIVER™, eupec™, FCOS™, HITFET™, HybridPACK™, Infineon™, ISOFACE™, IsoPACK™, i-Wafer™, MIPAQ™, ModSTACK™, my-d™, NovalithIC™, OmniTune™, OPTIGA™, OptiMOS™, ORIGA™, POWERCODE™, PRIMARION™, PrimePACK™, PrimeSTACK™, PROFET™, PRO-SIL™, RASIC™, REAL3™, ReverSave™, SatRIC™, SIEGET™, SIPMOS™, SmartLEWIS™, SOLID FLASH™, SPOC™, TEMPFET™, thinQ!™, TRENCHSTOP™, TriCore™.

Trademarks updated August 2015

Other Trademarks

All referenced product or service names and trademarks are the property of their respective owners.

Edition 13.02.2019

Published by

Infineon Technologies AG

81726 Munich, Germany

© 2019 Infineon Technologies AG.

All Rights Reserved.

Do you have a question about this document?

Email: erratum@infineon.com

Document reference

User Manual

IMPORTANT NOTICE

The information contained in this application note is given as a hint for the implementation of the product only and shall in no event be regarded as a description or warranty of a certain functionality, condition or quality of the product. Before implementation of the product, the recipient of this application note must verify any function and other technical information given herein in the real application. Infineon Technologies hereby disclaims any and all warranties and liabilities of any kind (including without limitation warranties of non-infringement of intellectual property rights of any third party) with respect to any and all information given in this application note.

The data contained in this document is exclusively intended for technically trained staff. It is the responsibility of customer's technical departments to evaluate the suitability of the product for the intended application and the completeness of the product information given in this document with respect to such application.

For further information on the product, technology, delivery terms and conditions and prices please contact your nearest Infineon Technologies office (www.infineon.com).

WARNINGS

Due to technical requirements products may contain dangerous substances. For information on the types in question please contact your nearest Infineon Technologies office.

Except as otherwise explicitly approved by Infineon Technologies in a written document signed by authorized representatives of Infineon Technologies, Infineon Technologies' products may not be used in any applications where a failure of the product or any consequences of the use thereof can reasonably be expected to result in personal injury.

单击下面可查看定价，库存，交付和生命周期等信息

[>>Infineon\(英飞凌\)](#)