

# ISP752R

## Smart power high-side-switch for industrial applications



### Features

- Overload protection
- Current limitation
- Short circuit protection
- Thermal shutdown with restart
- ESD-protection
- Overvoltage protection (including load dump)
- Fast demagnetization of inductive loads
- Reverse battery protection with external resistor
- Open drain diagnostic output for overtemperature and short circuit
- Open load detection in OFF-state with external resistor
- CMOS compatible input
- Loss of GND and loss of  $V_{bb}$  protection
- Very low standby current
- Green product (RoHS compliant)



### Potential applications

- All types of resistive, inductive and capacitive loads
- $\mu$ C compatible power switch for 12 V, 24 V and 42 V DC industrial applications
- Replaces electromechanical relays and discrete circuits

### Product validation

Qualified for industrial applications according to the relevant tests of JEDEC JESD47/20/22.

### Description

**Table 1** Product summary

Parameter	Symbol	Value	Unit
Overvoltage protection	$V_{bb(AZ)}$	62	V
Operating voltage	$V_{bb(on)}$	6 to 52	V
On-state resistance	$R_{ON}$	200	m $\Omega$
Nominal load current	$I_{L(nom)}$	1.3	A
Operating temperature	$T_a$	-30 to +85	$^{\circ}$ C

# ISP752R

## Smart power high-side-switch for industrial applications



---

### Description

N channel vertical power FET with charge pump, ground referenced CMOS compatible input and diagnostic feedback, monolithically integrated with embedded protective functions.

Type	Package	Marking
ISP752R	PG-DSO-8	I752R

## Table of contents

	<b>Features</b> .....	1
	<b>Potential applications</b> .....	1
	<b>Product validation</b> .....	1
	<b>Description</b> .....	1
	<b>Table of contents</b> .....	3
<b>1</b>	<b>Block diagram</b> .....	4
<b>2</b>	<b>Pin configuration</b> .....	5
<b>3</b>	<b>General product characteristics</b> .....	6
3.1	Absolute maximum ratings .....	6
3.2	Thermal resistance .....	7
<b>4</b>	<b>Functional description and electrical characteristics</b> .....	8
4.1	Functional description .....	8
4.2	Electrical characteristics .....	12
4.3	Typical performance characteristics .....	15
4.4	Timing diagrams .....	20
<b>5</b>	<b>Package information</b> .....	22
<b>6</b>	<b>Revision history</b> .....	23
	<b>Disclaimer</b> .....	24

Block diagram

1 Block diagram

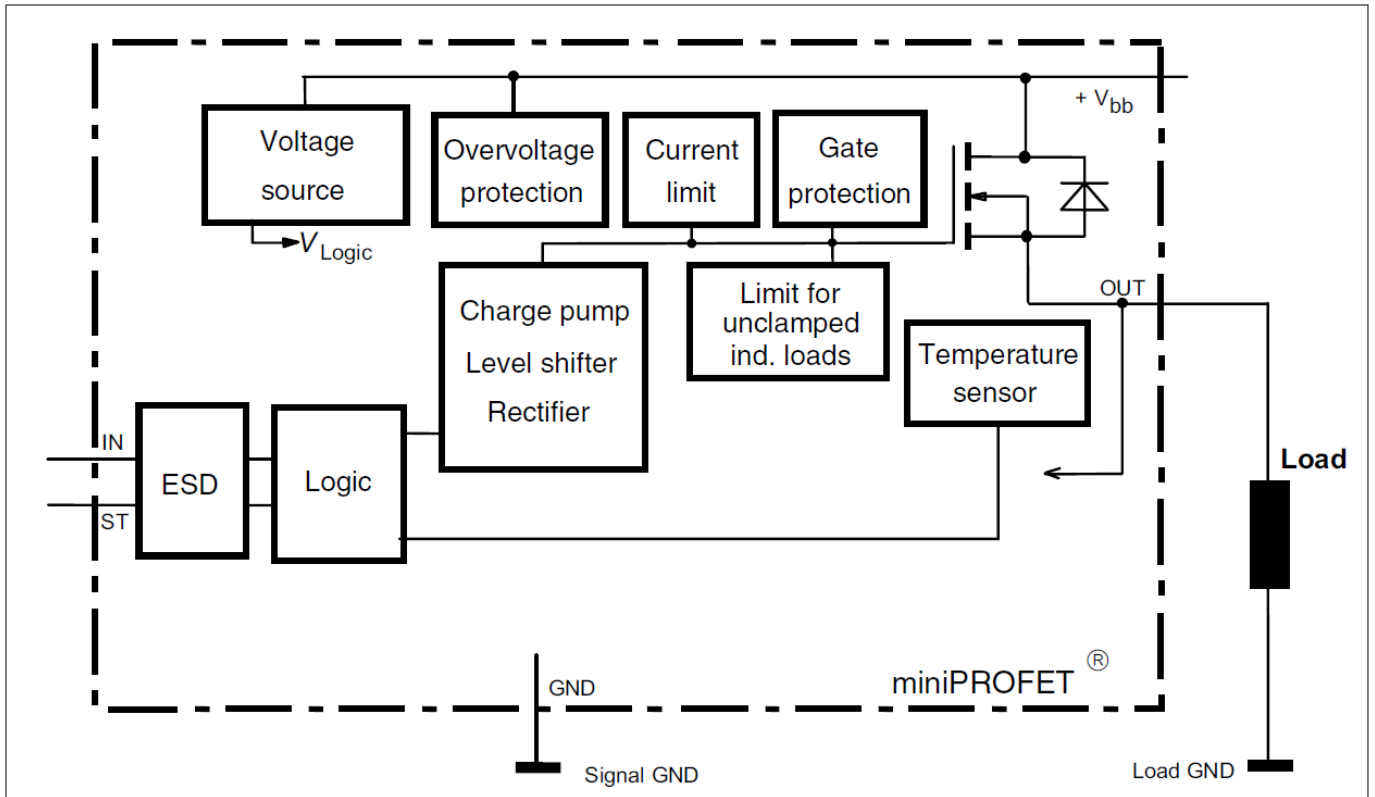
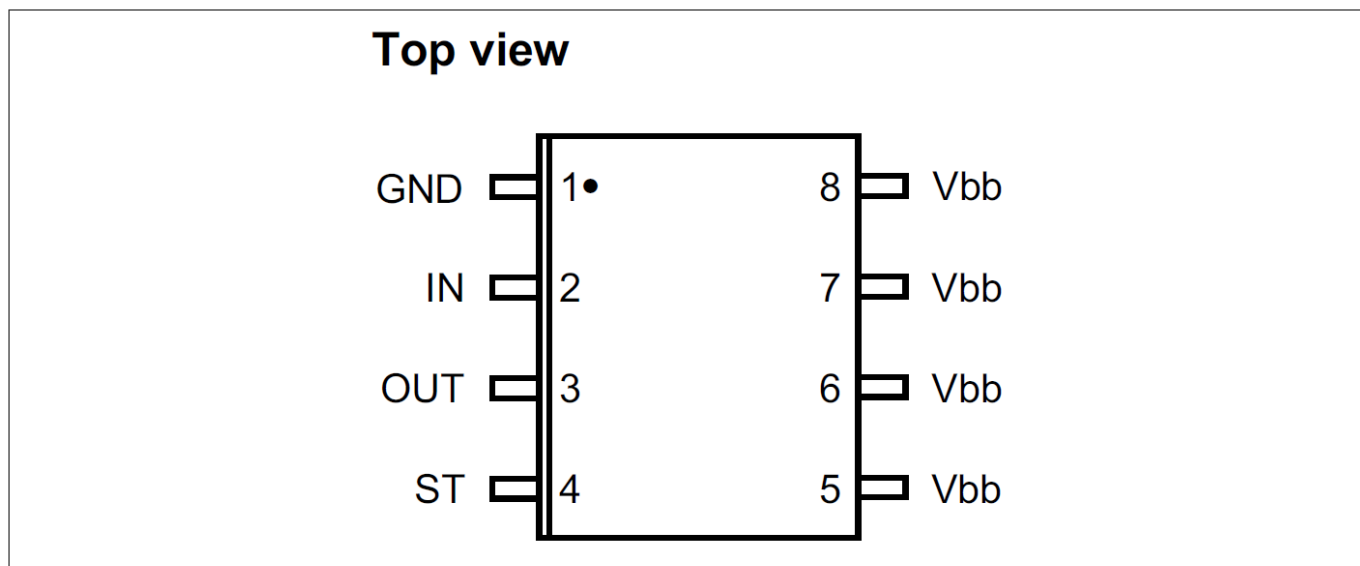

Figure 1 Block diagram

Pin configuration

## 2 Pin configuration



**Figure 2** Pin configuration

Pin	Symbol	Function
1	GND	Logic ground
2	IN	Input, activates the power switch in case of logic high signal
3	OUT	Output to the load
4	ST	Diagnostic feedback
5	Vbb	Positive power supply voltage
6	Vbb	Positive power supply voltage
7	Vbb	Positive power supply voltage
8	Vbb	Positive power supply voltage

General product characteristics

### 3 General product characteristics

#### 3.1 Absolute maximum ratings

**Table 2** Maximum ratings

$T_j = 25^\circ\text{C}$ , unless otherwise specified

Parameter	Symbol	Value	Unit	Note or condition
Supply voltage	$V_{bb}$	52	V	–
Supply voltage for full short circuit protection	$V_{bb(SC)}$	50	V	–
Continuous input voltage	$V_{IN}$	-10 to +16	V	–
Load current	$I_L$	self limited	A	short-circuit current, see p. <a href="#">12</a>
Current through input pin (DC)	$I_{IN}$	$\pm 5$	mA	–
Junction temperature	$T_j$	150	$^\circ\text{C}$	–
Operating temperature	$T_a$	-30 to +85	$^\circ\text{C}$	–
Storage temperature	$T_{stg}$	-40 to +105	$^\circ\text{C}$	–
Power dissipation	$P_{tot}$	1.5	W	<a href="#">1)</a>
Inductive load switch-off energy dissipation	$E_{AS}$	125	mJ	<a href="#">1)</a> <a href="#">2)</a> single pulse $T_j = 150^\circ\text{C}$ , $I_L = 1\text{ A}$ (see page <a href="#">11</a> )
Load dump protection $R_L = 13.5\ \Omega$ $R_L = 27\ \Omega$	$V_{Loaddump}$	73.5 83.5	V	<a href="#">2)</a> <a href="#">3)</a> $V_{LoadDump} = V_A + V_S$ , $R_I = 2\ \Omega$ , $t_d = 400\text{ ms}$ , $V_{IN} = \text{low or high}$ , $V_A = 13.5\text{ V}$
Electrostatic Discharge Voltage (Human Body Model) OUT IN all other pins	$V_{ESD}$	$\pm 6$ $\pm 1$ $\pm 4$	kV	according to ANSI/ESDA/JEDEC JS001 (1.5 k $\Omega$ , 100 pF)

<sup>1</sup> Device on 50 mm × 50 mm × 1.5 mm epoxy PCB FR4 with 6 cm<sup>2</sup> (one layer, 70  $\mu\text{m}$  thick) copper area for drain connection. PCB is vertical without blown air (see page [22](#))

<sup>2</sup> Not subject to production test, specified by design

<sup>3</sup>  $V_{Loaddump}$  is set up without the DUT connected to the generator per ISO 7637-1 and DIN 40839. Supply voltages higher than  $V_{bb(AZ)}$  require an external current limit for the GND pin, e.g. with a 150  $\Omega$  resistor in GND connection. A resistor for the protection of the input is integrated.

**General product characteristics**

**3.2 Thermal resistance**

**Table 3 Thermal resistance**

Parameter	Symbol	Values			Unit	Note or condition
		Min.	Typ.	Max.		
Thermal resistance minimum footprint 6 cm <sup>2</sup> cooling area <sup>4)</sup>	$R_{th(JA)}$	–	95 70	– 83	K/W	–

<sup>4</sup> Device on 50 mm × 50 mm × 1.5 mm epoxy PCB FR4 with 6 cm<sup>2</sup> (one layer, 70 μm thick) copper area for drain connection. PCB is vertical without blown air (see page 22)

**Functional description and electrical characteristics**

**4 Functional description and electrical characteristics**

**4.1 Functional description**

	Input level	Output level	Status
Normal operation	L	L	H
	H	H	H
Short circuit to GND	L	L	H
	H	L <sup>5)</sup>	L
Short circuit to $V_{bb}$ (in off-state)	L	H	L
	H	H	H
Overload	L	L	H
	H	H <sup>6)</sup>	H
Overtemperature	L	L	H
	H	L	L
Open load in off-state	L	Z <sup>7)</sup>	H (L <sup>8)</sup> )
	H	H	H

<sup>5</sup> Out = "L":  $V_{OUT} < 2.8\text{ V}$  typ.

<sup>6</sup> Out = "H":  $V_{OUT} > 2.8\text{ V}$  typ.

<sup>7</sup> Z = high impedance, potential depends on external circuit

<sup>8</sup> with external resistor between  $V_{bb}$  and OUT



**Functional description and electrical characteristics**

**Terms**

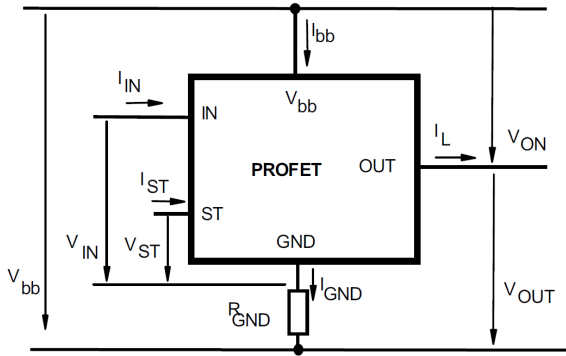

**Inductive and overvoltage output clamp**

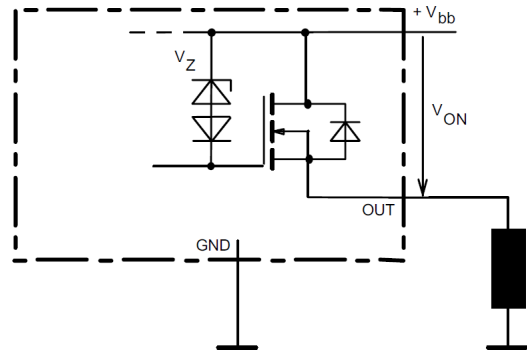

$V_{ON}$  clamped to 59 V min.

**Input circuit (ESD protection)**

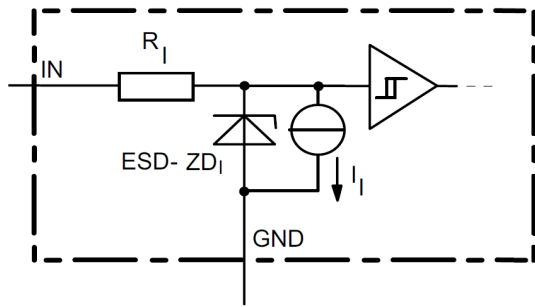

The use of ESD zener diodes as voltage clamp at DC conditions is not recommended

**Overvoltage protection of logic part**

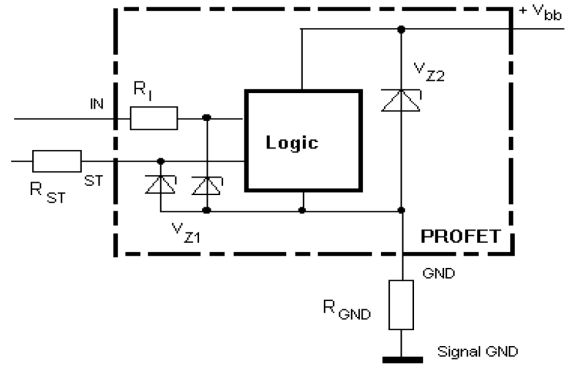

$V_{Z1} = 6.1 \text{ V typ.}$ ,  $V_{Z2} = V_{bb(AZ)} = 62 \text{ V min.}$ ,  
 $R_I = 3.5 \text{ k}\Omega \text{ typ.}$ ,  $R_{GND} = 150 \Omega$

**Functional description and electrical characteristics**

**Reverse battery protection**

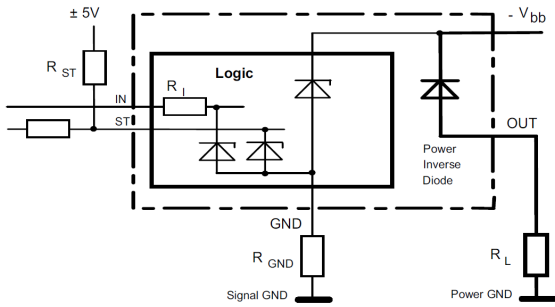

$R_{GND} = 150 \Omega$ ,  $R_I = 3.5 \text{ k}\Omega$  typ.,  
 Temperature protection is not active during inverse current

**Status output**

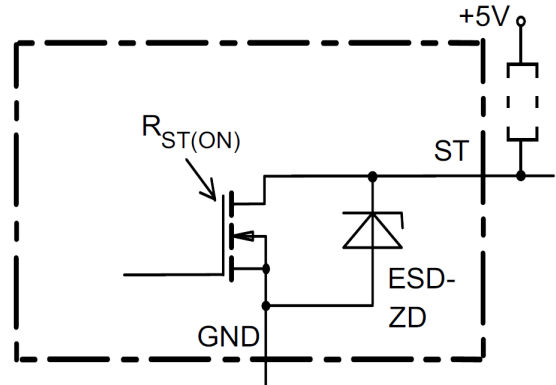

**Open-load detection**

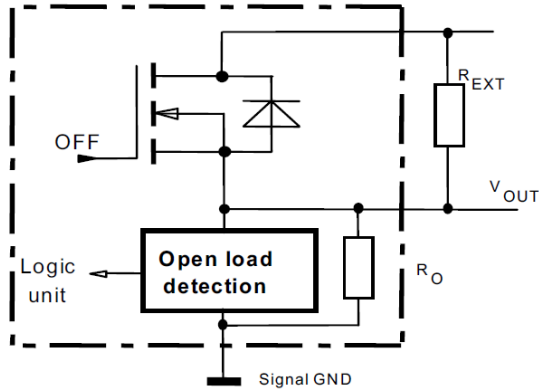

OFF-state diagnostic condition:  
 $V_{OUT} > 3 \text{ V}$  typ.;  $IN = \text{low}$

**$V_{bb}$  disconnect with charged inductive load**

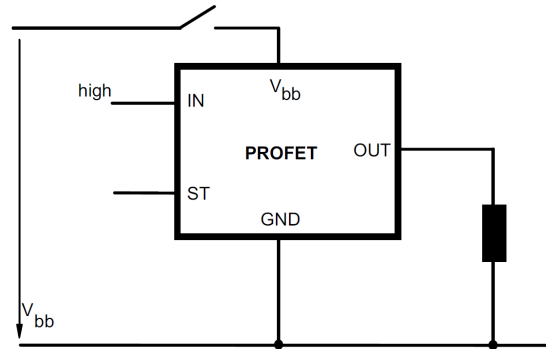

**Functional description and electrical characteristics**

**GND disconnect**

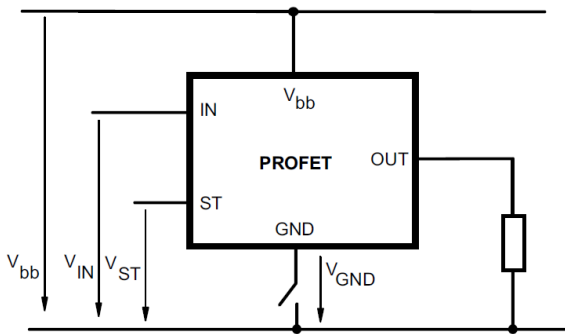

**GND disconnect with GND pull up**

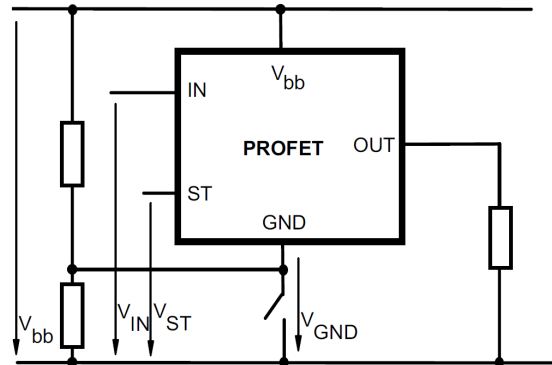

**Inductive load switch-off energy dissipation**

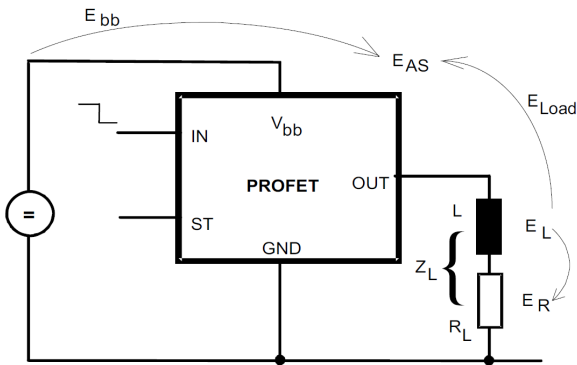

Energy stored in load inductance:

$$E_L = 1/2 \times L \times I_L^2$$

While demagnetizing load inductance, the energy dissipated in PROFET is

$$E_{AS} = E_{bb} + E_L - E_R = V_{ON(CL)} \times I_L(t) dt$$

with an approximate solution for  $R_L > 0 \Omega$ :

$$E_{AS} = \frac{I_L \times L}{2 \times R_L} \times (V_{bb} + |V_{OUT(CL)}|) \times \ln\left(1 + \frac{I_L \times R_L}{|V_{OUT(CL)}|}\right)$$

**Functional description and electrical characteristics**

**4.2 Electrical characteristics**

**Table 4 Electrical characteristics**

at  $T_j = -40^\circ\text{C}$  to  $+150^\circ\text{C}$ ,  $V_{bb} = 12\text{ V}$  to  $42\text{ V}$ , unless otherwise specified

Parameter	Symbol	Values			Unit	Note or condition
		Min.	Typ.	Max.		
<b>Load switching capabilities and characteristics</b>						
On-state resistance $T_j = 25^\circ\text{C}$ , $I_L = 1\text{ A}$ , $V_{bb} = 9\text{ V}$ to $52\text{ V}$ $T_j = 150^\circ\text{C}$	$R_{ON}$	–	150 270	200 380	mΩ	–
Nominal load current	$I_{L(nom)}$	1.3	1.7	–	A	Device on PCB <sup>9)</sup> $T_C = 85^\circ\text{C}$ , $T_j \leq 150^\circ\text{C}$
Turn-on time to 90% $V_{OUT}$	$t_{on}$	–	80	180	μs	$R_L = 47\ \Omega$
Turn-off time to 10% $V_{OUT}$	$t_{off}$	–	80	200	μs	$R_L = 47\ \Omega$
Slew rate on 10% to 30% $V_{OUT}$	$dV/dt_{on}$	–	0.7	2	V/μs	$R_L = 47\ \Omega$ , $V_{bb} = 13.5\text{ V}$
Slew rate off 70% to 40% $V_{OUT}$	$-dV/dt_{off}$	–	0.9	2	V/μs	$R_L = 47\ \Omega$ , $V_{bb} = 13.5\text{ V}$

**Operating parameters**

Operating voltage	$V_{bb(on)}$	6	–	52	V	–
Undervoltage shutoff charge pump $T_j = -40^\circ\text{C}$ to $+85^\circ\text{C}$ $T_j = 150^\circ\text{C}$	$V_{bb(under)}$	–	–	4 5.5	V	–
Undervoltage restart of charge pump	$V_{bb(u\ cp)}$	–	4	5.5	V	–
Standby current $T_j = -40^\circ\text{C}$ to $+85^\circ\text{C}$ , $V_{IN} = \text{low}$ $T_j = 150^\circ\text{C}$ <sup>10)</sup> , $V_{IN} = \text{low}$	$I_{bb(off)}$	–	–	15 18	μA	–
Leakage output current (included in $I_{bb(off)}$ )	$I_{L(off)}$	–	–	5	μA	$V_{IN} = \text{low}$
Operating current	$I_{GND}$	–	0.8	2	mA	$V_{IN} = \text{high}$

**Protection functions <sup>11)</sup>**

Initial peak short circuit current limit $T_j = -40^\circ\text{C}$ , $V_{bb} = 20\text{ V}$ , $t_m = 150\ \mu\text{s}$ $T_j = 25^\circ\text{C}$	$I_{L(SCp)}$	–	–	9 6.5	A	(pin 5 to 3) – –
---	--------------	---	---	----------	---	------------------------

<sup>9)</sup> Device on  $50\text{ mm} \times 50\text{ mm} \times 1.5\text{ mm}$  epoxy PCB FR4 with  $6\text{ cm}^2$  (one layer,  $70\ \mu\text{m}$  thick) copper area for drain connection. PCB is vertical without blown air (see page 22)

<sup>10)</sup> Higher current due temperature sensor

<sup>11)</sup> Integrated protection functions are designed to prevent IC destruction under fault conditions described in the data sheet. Fault conditions are considered as "outside" normal operating range. Protection functions are not designed for continuous repetitive operation.

**Functional description and electrical characteristics**

**Table 4 Electrical characteristics (continued)**

at  $T_j = -40^\circ\text{C}$  to  $+150^\circ\text{C}$ ,  $V_{bb} = 12\text{ V}$  to  $42\text{ V}$ , unless otherwise specified

Parameter	Symbol	Values			Unit	Note or condition
		Min.	Typ.	Max.		
$T_j = 150^\circ\text{C}$		4	–	–		–
$T_j = -40^\circ\text{C}$ to $+150^\circ\text{C}$ , $V_{bb} > 40\text{ V}$ (see p. 17)		–	5 <sup>12)</sup>	–		–
Repetitive short circuit current limit, $T_j = T_{jt}$ $V_{bb} < 40\text{ V}$ $V_{bb} > 40\text{ V}$	$I_{L(SCr)}$	–	6 4.5	–	A	(see <a href="#">Timing diagrams</a> )
Output clamp (inductive load switch off)	$V_{ON(CL)}$	59	63	–	V	$V_{OUT} = V_{bb} - V_{ON(CL)}$ , $I_{bb} = 4\text{ mA}$
Overvoltage protection	$V_{bb(AZ)}$	62	–	–	V	<sup>13)</sup> $I_{bb} = 4\text{ mA}$
Thermal overload trip temperature	$T_{jt}$	150	–	–	$^\circ\text{C}$	–
Thermal hysteresis	$\Delta T_{jt}$	–	10	–	K	–

**Reverse battery**

Reverse battery	$-V_{bb}$	–	–	52	V	<sup>14)</sup>
Drain-source diode voltage ( $V_{OUT} > V_{bb}$ )	$-V_{ON}$	–	600	–	mV	$T_j = 150^\circ\text{C}$

**Input and status feedback**

Input turn-on threshold voltage	$V_{IN(T+)}$	–	–	2.2	V	–
Input turn-off threshold voltage	$V_{IN(T-)}$	0.8	–	–	V	–
Input threshold hysteresis	$\Delta V_{IN(T)}$	–	0.4	–	V	–
Off state input current $V_{IN} = 0.7\text{ V}$	$I_{IN(off)}$	1	–	25	$\mu\text{A}$	–
On state input current	$I_{IN(on)}$	3	–	25	$\mu\text{A}$	$V_{IN} = 5\text{ V}$
Status output (open drain), Zener limit voltage	$V_{ST(high)}$	5.4	6.1	–	V	$I_{ST} = 1.6\text{ mA}$
Status output (open drain), ST low voltage $T_j = -40^\circ\text{C}$ to $+25^\circ\text{C}$ , $I_{ST} = 1.6\text{ mA}$ $T_j = 150^\circ\text{C}$ , $I_{ST} = 1.6\text{ mA}$	$V_{ST(low)}$	–	–	0.4 0.6	V	–
Status invalid after positive input slope	$t_{d(ST+)}$	–	120	160	$\mu\text{s}$	<sup>15)</sup>

<sup>12</sup> Not subject to production test, specified by design

<sup>13</sup> see also  $V_{ON(CL)}$  in circuit diagram on page 9

<sup>14</sup> Requires a  $150\ \Omega$  resistor in GND connection. The reverse load current through the intrinsic drain-source diode has to be limited by the connected load. Power dissipation is higher compared to normal operating conditions due to the voltage drop across the drain-source diode. The temperature protection is not active

**Functional description and electrical characteristics**

**Table 4 Electrical characteristics (continued)**

at  $T_j = -40^\circ\text{C}$  to  $+150^\circ\text{C}$ ,  $V_{bb} = 12\text{ V}$  to  $42\text{ V}$ , unless otherwise specified

Parameter	Symbol	Values			Unit	Note or condition
		Min.	Typ.	Max.		
						$V_{bb} = 20\text{ V}$
Status invalid after negative input slope <sup>15)</sup>	$t_{d(ST-)}$	–	250	400	$\mu\text{s}$	–
Input resistance	$R_I$	2	3.5	5	$\text{k}\Omega$	see page 9

**Diagnostic characteristics**

Short circuit detection voltage	$V_{OUT(SC)}$	–	2.8	–	V	–
Open load detection voltage	$V_{OUT(OL)}$	–	3	4	V	<sup>16)</sup>
Internal output pull down	$R_O$	–	200	–	$\text{k}\Omega$	<sup>17)</sup> $V_{OUT(OL)} = 4\text{ V}$ (see page 10 and page 19)

during reverse current operation! Input current has to be limited (see **Absolute maximum ratings** on page 6).

<sup>15)</sup> No delay time after overtemperature switch off and short circuit in on-state

<sup>16)</sup> External pull up resistor required for open load detection in off state

<sup>17)</sup> Not subject to production test, specified by design

**Functional description and electrical characteristics**

**4.3 Typical performance characteristics**

**Typ. transient thermal impedance  $Z_{thJA} = f(t_p)$   
 @ 6 cm<sup>2</sup> heatsink area**

$D = t_p/T$

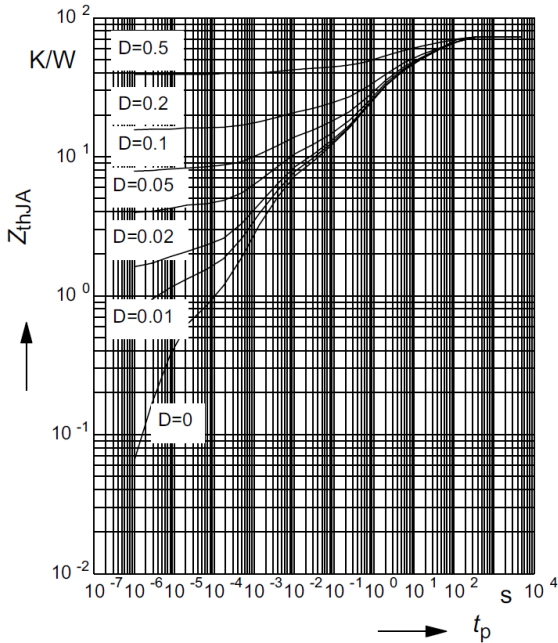

**Typ. transient thermal impedance  $Z_{thJA} = f(t_p)$   
 @ minimum footprint**

$D = t_p/T$

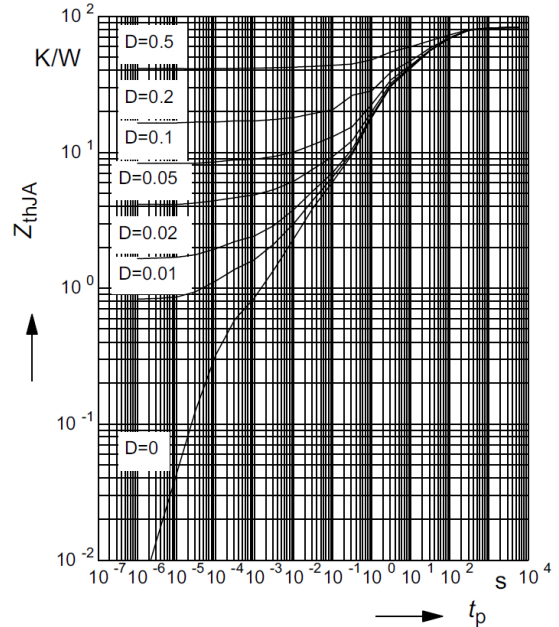

**Typ. on-state resistance  $R_{ON} = f(T_j)$**

$V_{bb} = 13.5\text{ V}; V_{IN} = \text{high}$

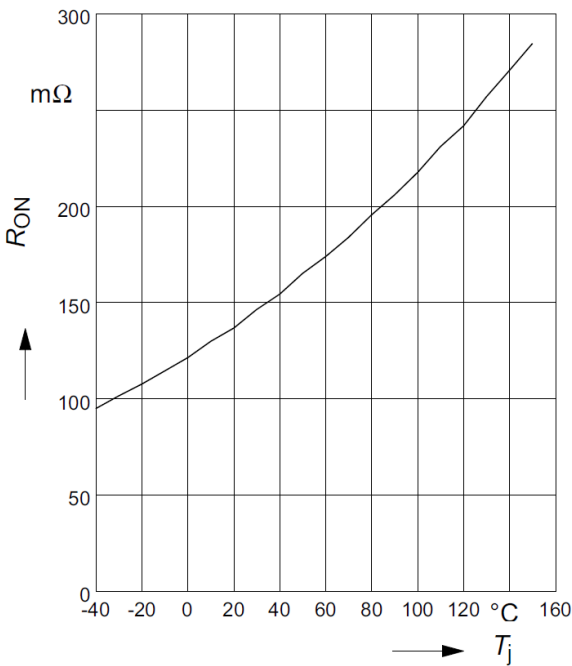

**Typ. on-state resistance  $R_{ON} = f(V_{bb})$**

$I_L = 1\text{ A}; V_{IN} = \text{high}$

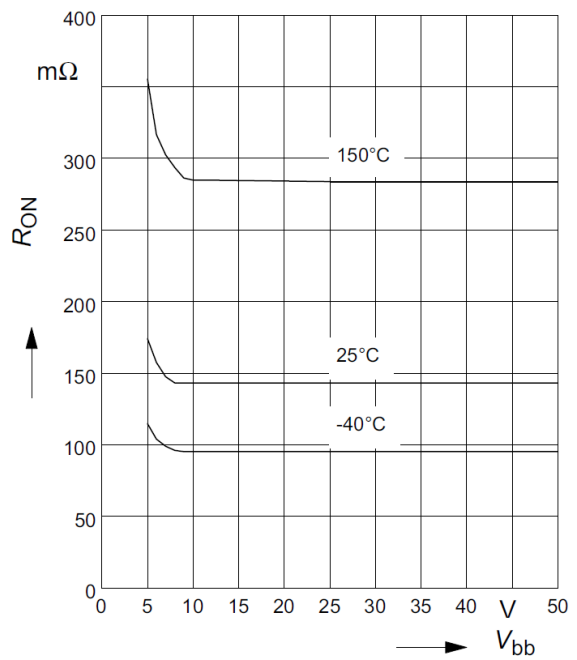

**Functional description and electrical characteristics**

**Typ. turn-on time  $t_{on} = f(T_j)$**

$R_L = 47 \Omega$

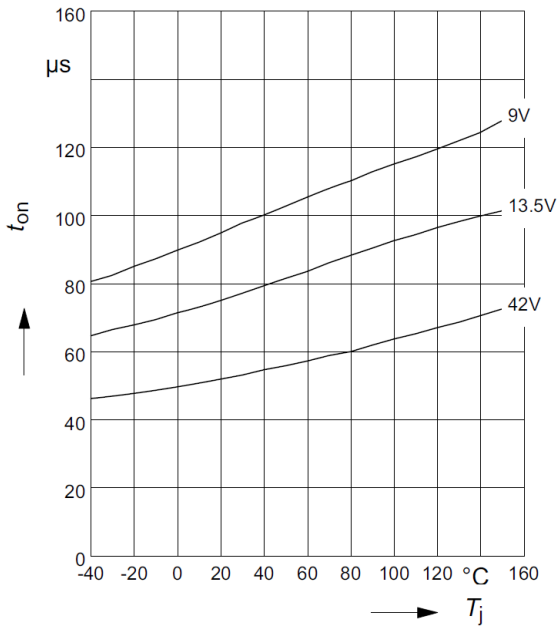

**Typ. turn-off time  $t_{off} = f(T_j)$**

$R_L = 47 \Omega$

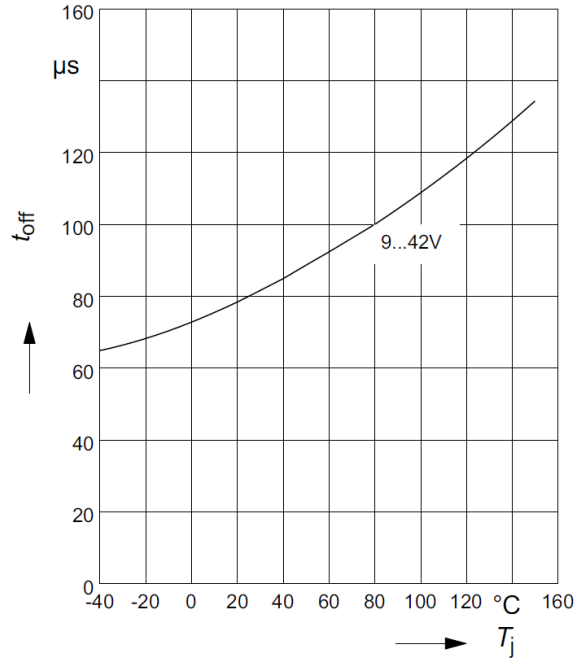

**Typ. slew rate on  $dV/dt_{on} = f(T_j)$**

$R_L = 47 \Omega$

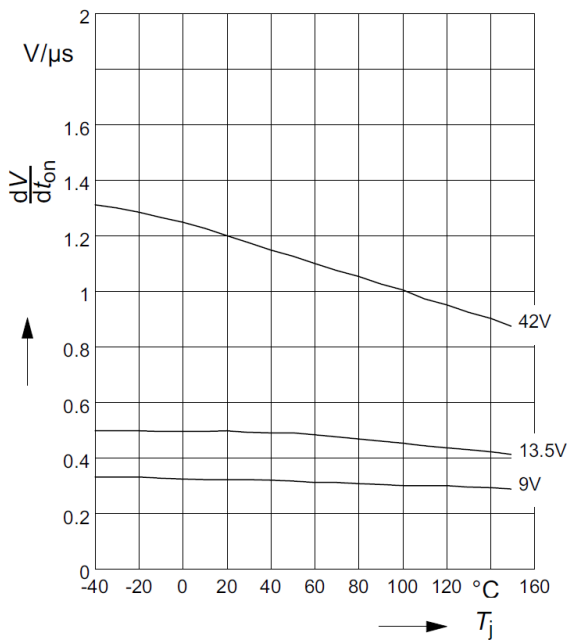

**Typ. slew rate off  $dV/dt_{off} = f(T_j)$**

$R_L = 47 \Omega$

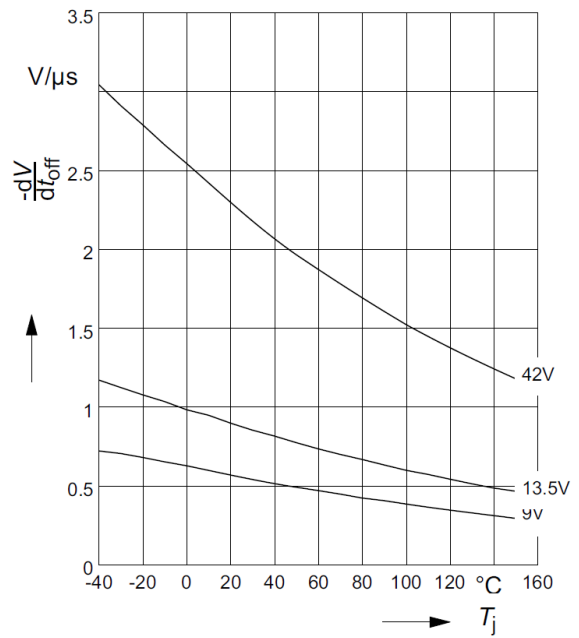



**Functional description and electrical characteristics**

**Typ. standby current  $I_{bb(off)} = f(T_j)$**

$V_{bb} = 42\text{ V}; V_{IN} = \text{low}$

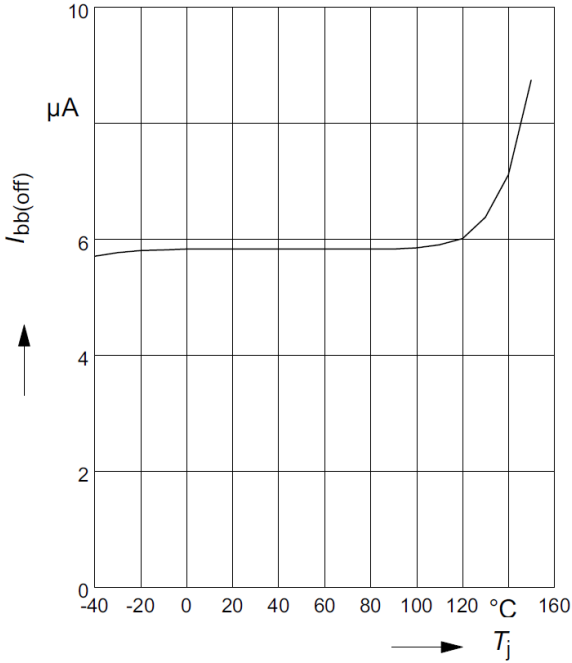

**Typ. leakage current  $I_{L(off)} = f(T_j)$**

$V_{bb} = 42\text{ V}; V_{IN} = \text{low}$

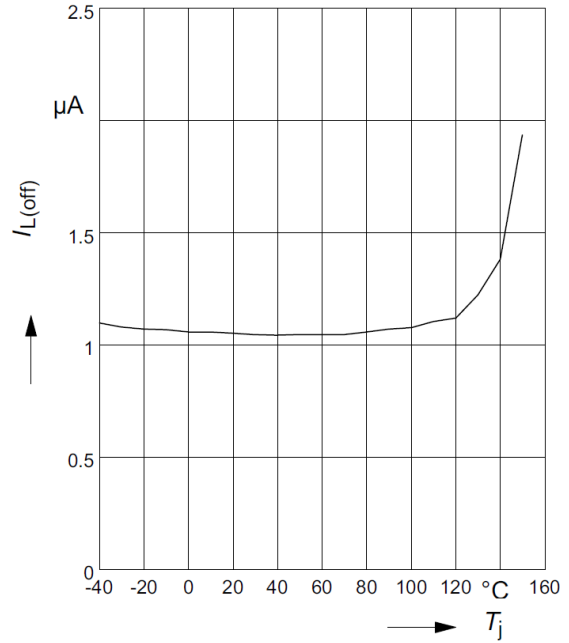

**Typ. initial peak short circuit current limit  $I_{L(SCp)} = f(V_{bb})$**

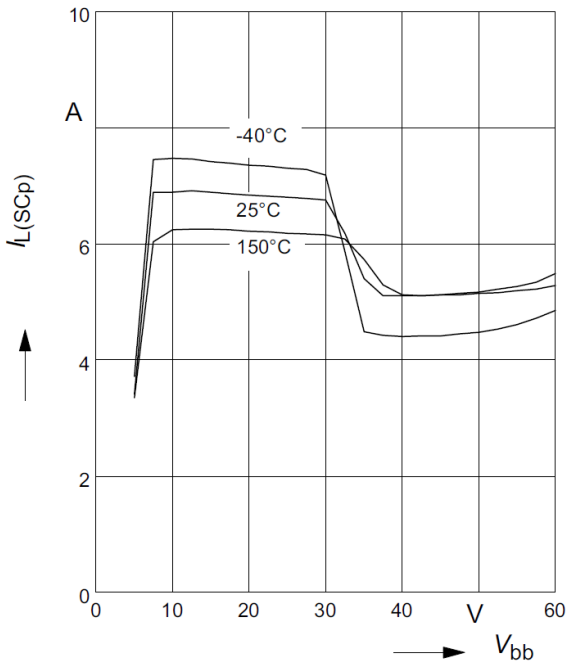

**Typ. initial short circuit shutdown time  $t_{off(SC)} = f(T_j, \text{start})$**

$V_{bb} = 20\text{ V}$

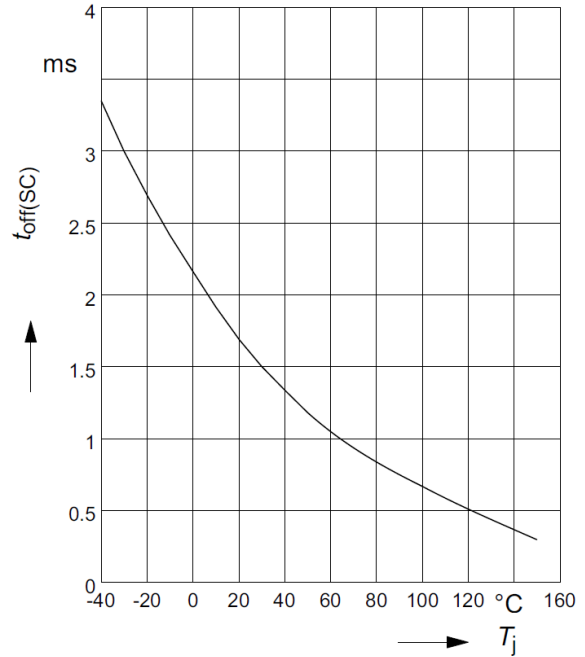

**Functional description and electrical characteristics**

**Typ. input current  $I_{IN(on/off)} = f(T_j)$**

$V_{bb} = 13.5\text{ V}$ ;  $V_{IN} = \text{low/high}$ ;  $V_{INlow} \leq 0.7\text{ V}$ ;  $V_{INhigh} = 5\text{ V}$

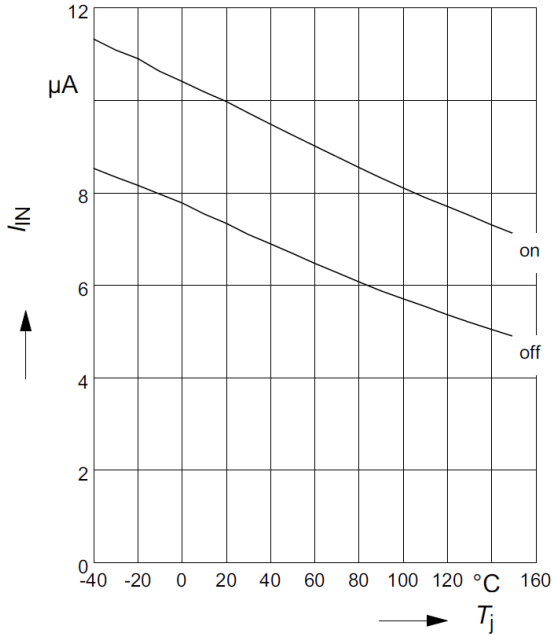

**Typ. input current  $I_{IN} = f(V_{IN})$**

$V_{bb} = 13.5\text{ V}$

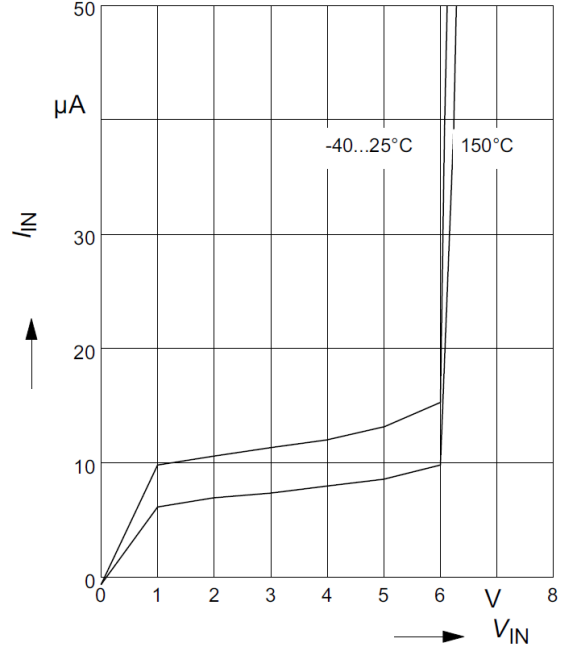

**Typ. input threshold voltage  $V_{IN(th)} = f(T_j)$**

$V_{bb} = 13.5\text{ V}$

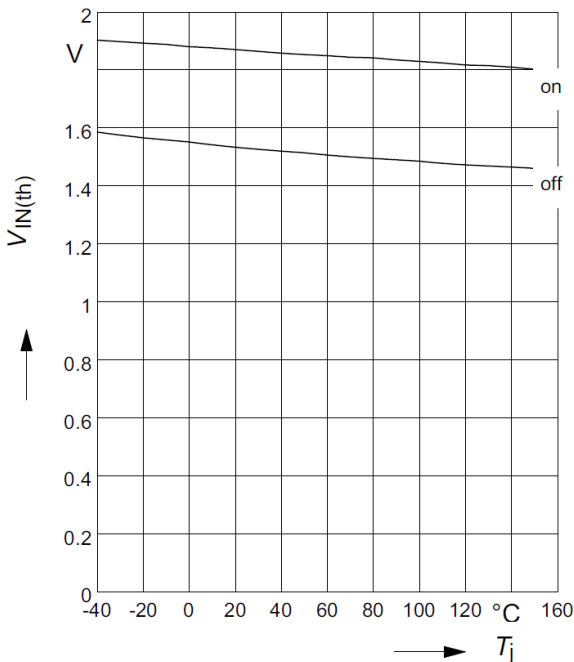

**Typ. input threshold voltage  $V_{IN(th)} = f(V_{bb})$**

$T_j = 25^{\circ}\text{C}$

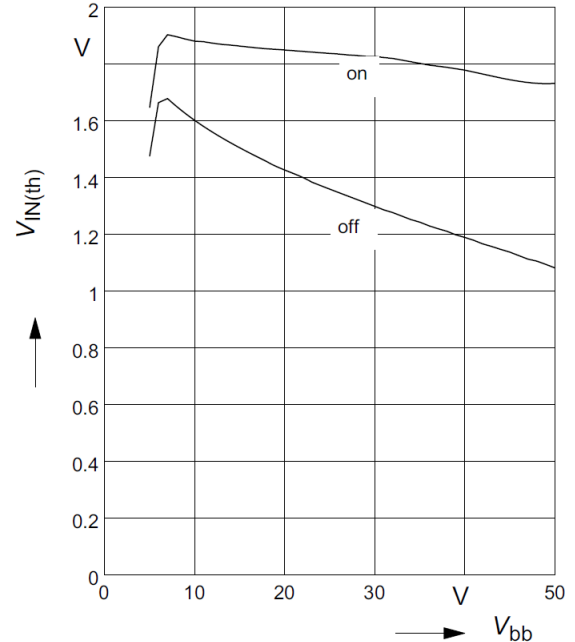

**Functional description and electrical characteristics**

**Maximum allowable load inductance for a single switch off  $L = f(I_L)$**

$T_{jstart} = 150^{\circ}\text{C}$ ,  $R_L = 0 \Omega$

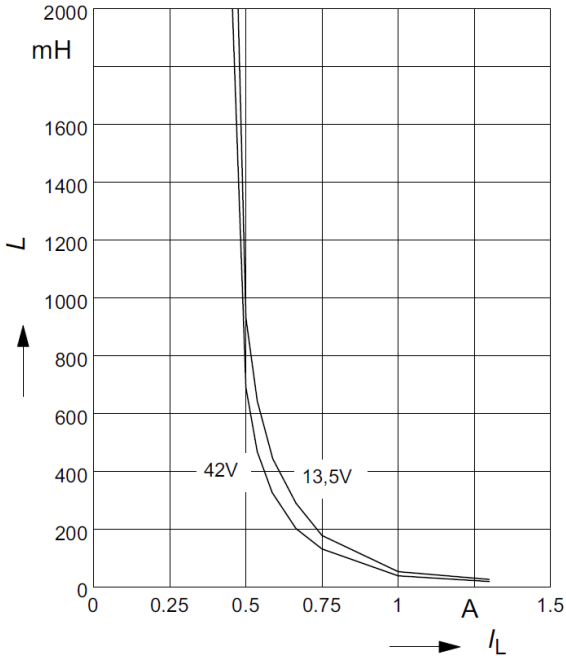

**Typ. status delay time  $t_{d(ST)} = f(V_{bb})$**

$T_j = 25^{\circ}\text{C}$

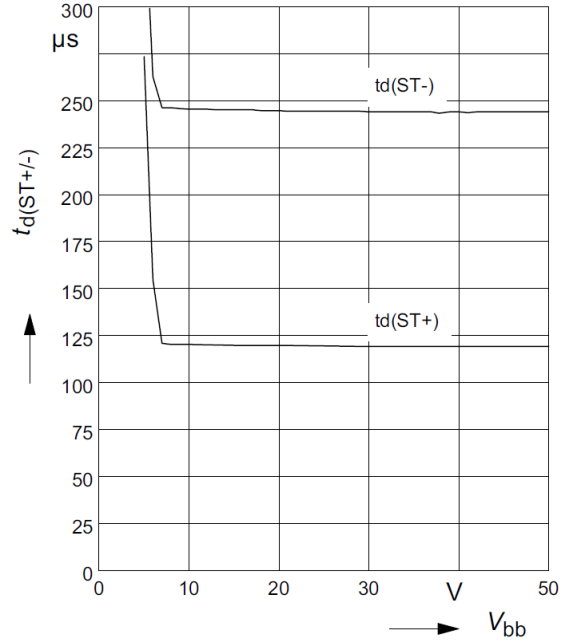

**Maximum allowable inductive switch-off energy, single pulse  $E_{AS} = f(I_L)$**

$T_{jstart} = 150^{\circ}\text{C}$ ,  $V_{bb} = 13.5 \text{ V}$

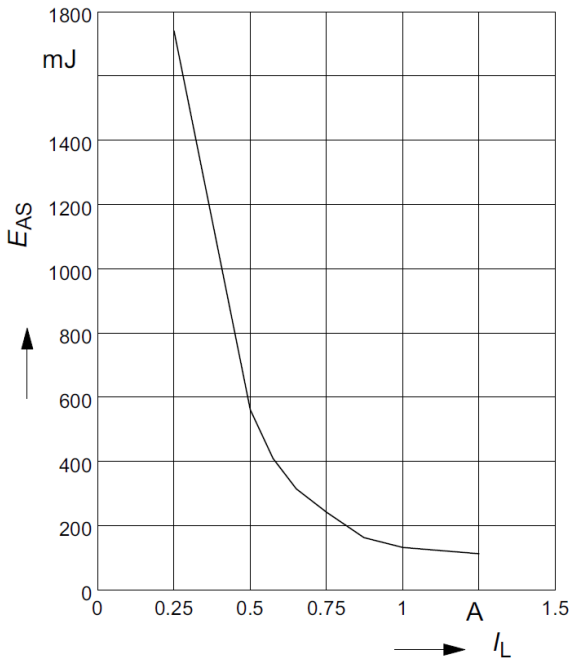

**Typ. internal output pull down  $R_O = f(V_{bb})$**

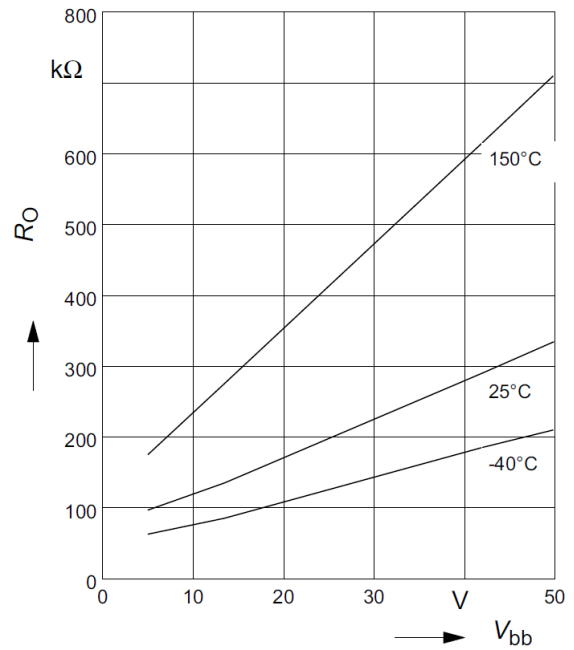

**Functional description and electrical characteristics**

**4.4 Timing diagrams**

**$V_{bb}$  turn on**

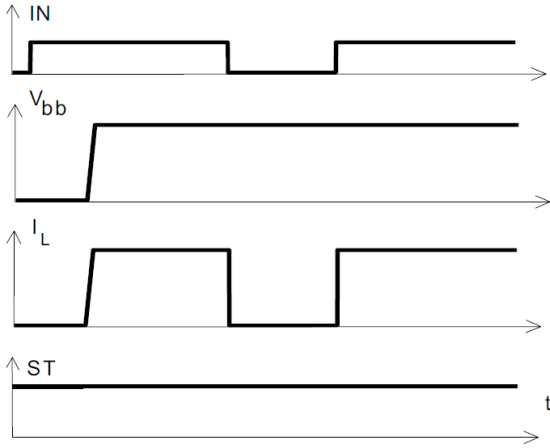

**Switching a lamp**

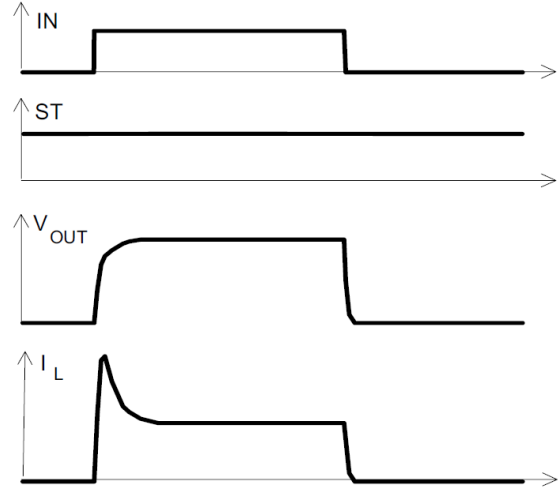

**Switching a resistive load, turn-on/off time and slew rate definition**

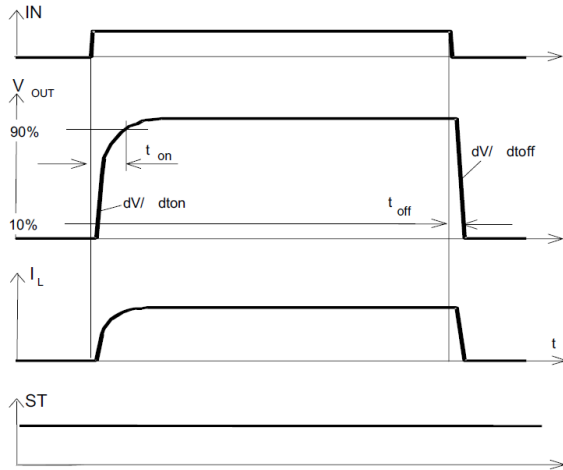

**Switching an inductive load**

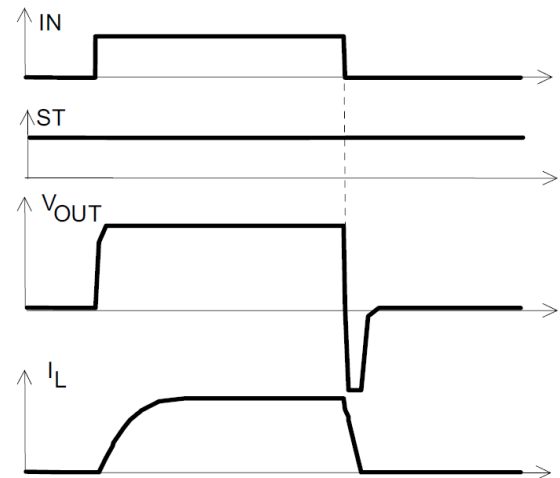

**Functional description and electrical characteristics**

**Turn on into short circuit, shut down by overtemperature, restart by cooling**

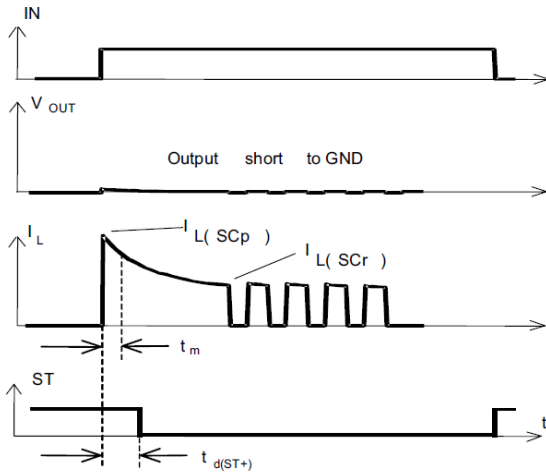

**Short circuit in on-state shut down by overtemperature, restart by cooling**

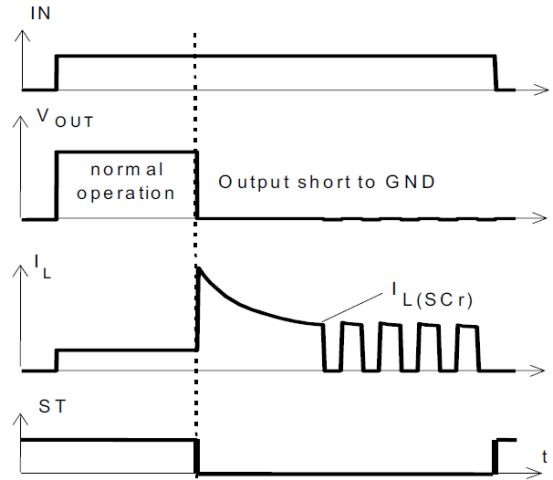

Heating up of the chip may require several milliseconds, depending on external conditions.

**Overtemperature: Reset if  $T_j < T_{jt}$**

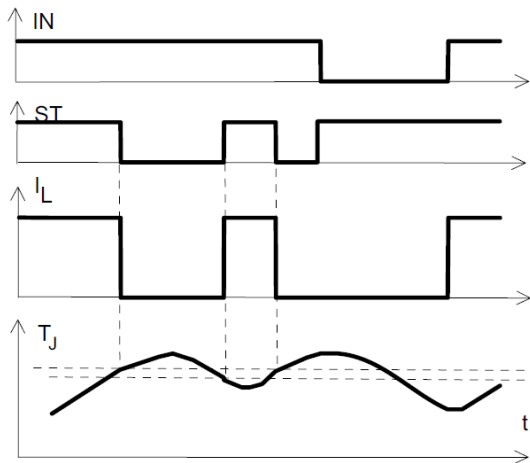

**Undervoltage restart of charge pump**

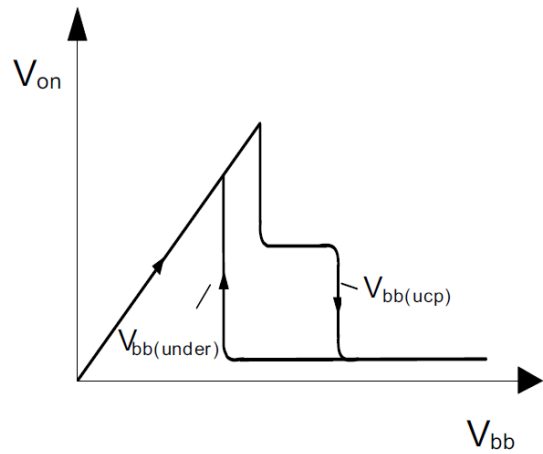

Package information

5 Package information

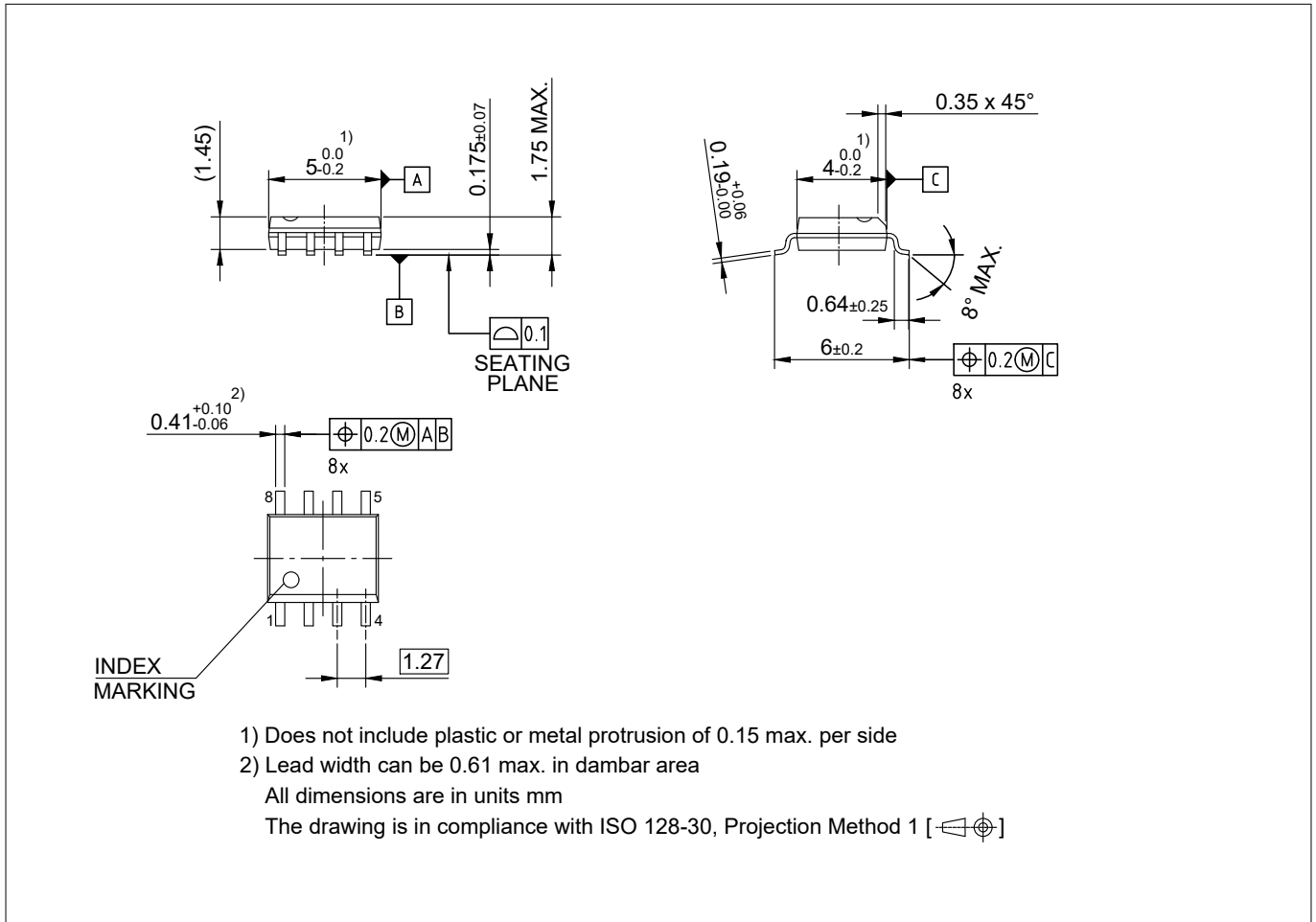

Figure 3 PG-DSO-8

Green Product (RoHS compliant)

To meet the world-wide customer requirements for environmentally friendly products and to be compliant with government regulations the device is available as a green product. Green products are RoHS-Compliant (Pb-free finish on leads and suitable for Pb-free soldering according to IPC/JEDEC J-STD-020).

Information on alternative packages

Please visit [www.infineon.com/packages](http://www.infineon.com/packages).

Revision history

## 6 Revision history

Document version	Date of release	Description of changes
1.2	2019-07-25	Datasheet updated: <ul style="list-style-type: none"><li>• ESD ratings for HBM updated according to ANSI/ESDA/JEDEC JS001</li><li>• Editorial changes</li></ul>
1.1	2008-09-26	All pages: <ul style="list-style-type: none"><li>• Added new Infineon logo</li><li>• Initial version of RoHS-compliant derivate of the ISP752R</li></ul> Page 1 and 17: <ul style="list-style-type: none"><li>• Added RoHS compliance statement and Green product feature</li><li>• Package changed to RoHS compliant version</li></ul> Page 18: Added Revision history Page 19: Update of disclaimer

## Trademarks

All referenced product or service names and trademarks are the property of their respective owners.

**Edition 2019-07-25**

**Published by**

**Infineon Technologies AG**

**81726 Munich, Germany**

**© 2019 Infineon Technologies AG**

**All Rights Reserved.**

**Do you have a question about any aspect of this document?**

**Email: [erratum@infineon.com](mailto:erratum@infineon.com)**

**Document reference**

**IFX-Z8F64610014**

## IMPORTANT NOTICE

The information given in this document shall in no event be regarded as a guarantee of conditions or characteristics ("Beschaffheitsgarantie").

With respect to any examples, hints or any typical values stated herein and/or any information regarding the application of the product, Infineon Technologies hereby disclaims any and all warranties and liabilities of any kind, including without limitation warranties of non-infringement of intellectual property rights of any third party.

In addition, any information given in this document is subject to customer's compliance with its obligations stated in this document and any applicable legal requirements, norms and standards concerning customer's products and any use of the product of Infineon Technologies in customer's applications.

The data contained in this document is exclusively intended for technically trained staff. It is the responsibility of customer's technical departments to evaluate the suitability of the product for the intended application and the completeness of the product information given in this document with respect to such application.

Please note that this product is not qualified according to the AEC Q100 or AEC Q101 documents of the Automotive Electronics Council.

## WARNINGS

Due to technical requirements products may contain dangerous substances. For information on the types in question please contact your nearest Infineon Technologies office.

Except as otherwise explicitly approved by Infineon Technologies in a written document signed by authorized representatives of Infineon Technologies, Infineon Technologies' products may not be used in any applications where a failure of the product or any consequences of the use thereof can reasonably be expected to result in personal injury



单击下面可查看定价，库存，交付和生命周期等信息

[>>Infineon\(英飞凌\)](#)