

GaN EiceDRIVER™ product family

Single-channel functional and reinforced isolated gate-drive ICs for high-voltage enhancement-mode GaN HEMTs

Features

- Dedicated gate driver ICs for high-voltage GaN power switches (CoolGaN™, GIT technology based products)
 - low driving impedance (on-resistance 0.85 Ω source, 0.35 Ω sink)
 - resistor programmable gate current (typ. 10 mA) in steady “on” state
 - programmable negative gate voltage to completely avoid spurious turn-on
- Single output supply voltage (typ. 8 V, floating)
- Switching behavior independent of duty-cycle (2 "off" voltage levels)
- Differential concept to ensure negative gate drive voltage under any condition
- Fast input-to-output propagation (37 ns) with excellent stability (+7/-6 ns)
- Galvanic input-to-output isolation based on coreless transformer (CT) technology
- Common mode transient immunity (CMTI) > 200 V/ns
- 3 package versions
 - 1EDF5673K: 13-pin LGA (5 x 5 mm, PG-TFLGA-13-1) for functional isolation (1.5 kV)
 - 1EDF5673F: 16-pin P-DSO (150 mil, PG-DSO-16-11) for functional isolation (1.5 kV)
 - 1EDS5663H: 16-pin P-DSO (300 mil, PG-DSO-16-30) for reinforced isolation
- Fully qualified according to JEDEC for Industrial Applications



Description

CoolGaN™ and similar GaN switches require a continuous gate current of a few mA in their "on" state. Besides, due to low threshold voltage and extremely fast switching transients, a negative "off" voltage level may be needed. The widely used RC-coupled gate driver fulfils these requirements, however it suffers from a duty-cycle dependence of switching dynamics and the lack of negative gate drive in specific situations.

Infineon's GaN EiceDRIVER™ solves these issues with very low effort. The two output stages shown below enable a zero “off” level to eliminate any duty-cycle dependence. In addition, the differential topology is able to provide negative gate drive without the need for a negative supply voltage. However, it requires a floating supply voltage not compatible with bootstrapping.

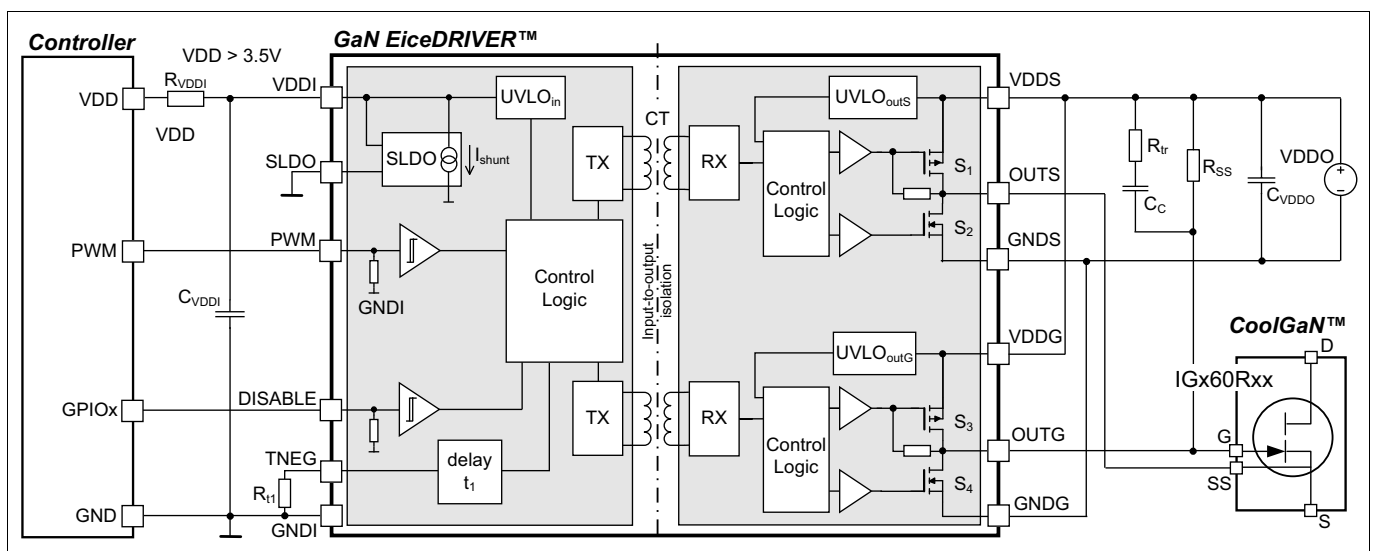

Potential applications

- Server, telecom and industrial SMPS
- Adapter and charger power supply

Isolation and safety approval

- 1EDS5663H with reinforced isolation: certification by VDE, UL, CSA, CQC according to
 - DIN V VDE V 0884-10 (2006-12) with $V_{IOTM} = 8 \text{ kV}_{pk}$, $V_{IOSM} = 6.25 \text{ kV}_{pk}$ (tested at 10 kV_{pk})
 - UL1577 (Ed. 5) with $V_{ISO} = 5.7 \text{ kV}_{RMS}$
 - IEC60950-1 and IEC62368-1 system standards and corresponding CQC certificates
- 1EDF5673K and 1EDF5673F with functional isolation: production test with 1.5 kV for 10 ms

Product versions

In accordance with the isolation classification for primary and secondary side control, GaN EiceDRIVER™ is available in different package versions

Table 1 GaN EiceDRIVER™ product family overview

Part number	Package	Source/sink output resistance	Input-to-output isolation			
			Isolation class	Rating	Surge testing	Safety certification
1EDF5673K	LGA-13 5 x 5 mm	0.85 Ω / 0.35 Ω	functional	$V_{IO} = 1.5 \text{ kV}_{DC}$	n.a	n.a
1EDF5673F	DSO-16 150 mil	0.85 Ω / 0.35 Ω	functional	$V_{IO} = 1.5 \text{ kV}_{DC}$	n.a	n.a
1EDS5663H	DSO-16 300 mil	0.85 Ω / 0.35 Ω	reinforced (safe)	$V_{IOTM} = 8 \text{ kV}_{pk}$ (VDE0884-10) $V_{ISO} = 5.7 \text{ kV}_{RMS}$ (UL1577)	$V_{IOSM} > 10 \text{ kV}_{pk}$ (IEC60065)	VDE0884-10 ¹⁾ UL1577 ²⁾ IEC60950-1 ²⁾ , 62368-1 (CQC) ²⁾

1) tested according to VDE0884-10 specifications with certification no longer available due to standard expiration

2) certification pending

Table of Contents

	Features	1
	Table of Contents	3
1	Pin configuration and description	4
2	Background and system description	6
3	Functional description	9
3.1	Block diagram	9
3.2	Isolation	9
3.3	Power supply	10
3.3.1	Input supply voltage	10
3.3.2	Output supply voltage	10
3.3.3	Power dissipation	10
3.4	Driver outputs	11
3.5	Undervoltage Lockout (UVLO)	11
3.6	CT communication and data transmission	11
3.7	Signal timing	11
4	Electrical characteristics	13
4.1	Absolute maximum ratings	13
4.2	Thermal characteristics	14
4.3	Operating range	15
4.4	Electrical characteristics	15
5	Timing diagrams	18
6	Typical characteristics	19
7	Isolation specifications	23
7.1	Functional isolation specifications	23
7.1.1	Functional isolation in PG-TFLGA-13-1 package (1EDF5673K)	23
7.1.2	Functional isolation in NB PG-DSO-16-11 package (1EDF5673F)	24
7.2	Reinforced isolation in WB PG-DSO-16-30 package (1EDS5663H)	25
7.3	Safety-limiting values	26
8	Application circuit	27
8.1	Dimensioning guidelines	27
9	Layout guidelines	29
10	Package outline dimensions	31
10.1	Package PG-TFLGA-13-1	31
10.2	Package PG-DSO-16-11	33
10.3	Package PG-DSO-16-30	34
11	Device numbers and markings	36
12	Revision History	37

Pin configuration and description

1 Pin configuration and description

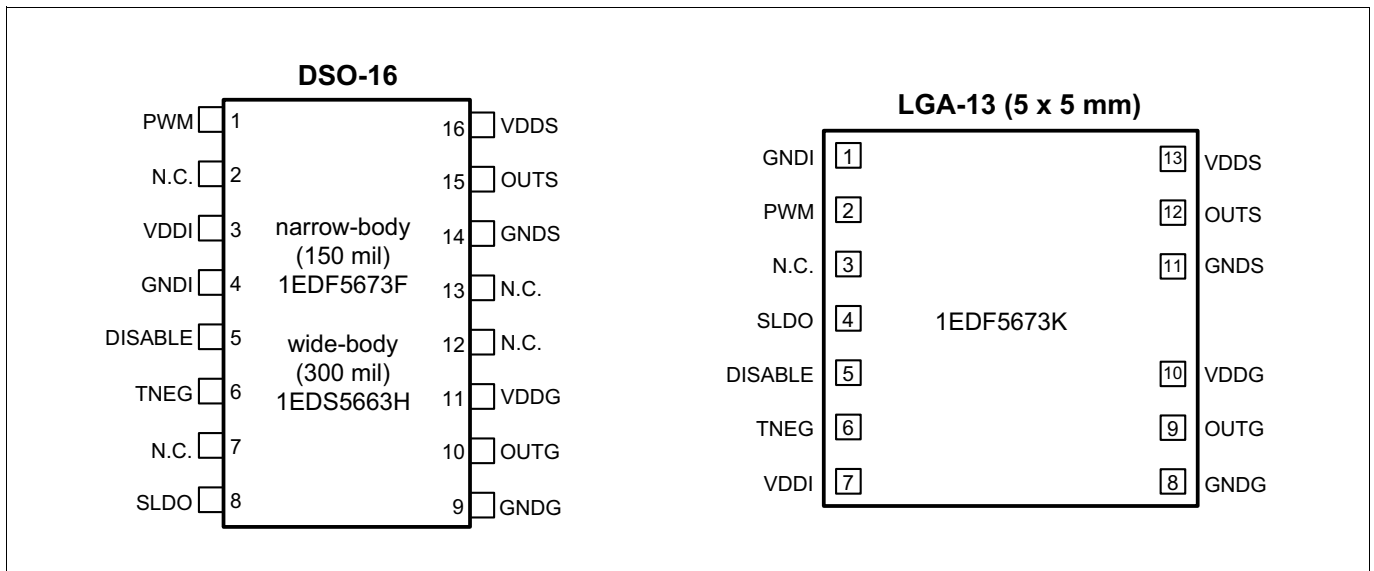

Figure 1 Pin configuration for DSO-16 and LGA-13 packages, top view

Table 2 Pin description

Pin DSO	Pin LGA	Symbol	Description
1	2	PWM	Input signal (default state Low) Controls switching sequence at OUTG and OUTS
2	3	N.C.	Do not connect
3	7	VDDI	Input supply voltage (+3.3 V)
4	1	GNDI	Input GND
5	5	DISABLE	Input signal (default state Low) Logic High is equivalent to a low state at PWM input
6	6	TNEG	Resistor programmable input to control the duration t_1 of negative "off" level (Figure 4); $t_1 = R_{t1} * 10.8 \text{ pF}$ with R_{t1} ranges from 3 k Ω to 45 k Ω , typical value of R_{t1} is 18 k Ω
7	7	N.C.	Not connected
8	4	SLDO	N.C. or connected to VDDI: applied voltage (3.3 V) directly used as input supply voltage Connected to GNDI: Internal shunt regulator activated (VDD > 3.5 V)
9	8	GNDG	Ground for OUTG
10	9	OUTG	Output connectd to GaN gate
11	10	VDDG	Positive supply voltage for gate connected output stage
12	-	N.C.	Not connected
13	-	N.C.	Not connected
14	11	GNDS	Ground for OUTS (has to be connected with GNDG)

Pin configuration and description**Table 2 Pin description**

Pin DSO	Pin LGA	Symbol	Description
15	12	OUTS	Output connected to GaN source
16	13	VDDS	Positive supply voltage for source connected output stage (has to be connected with VDDG)

Background and system description

2 Background and system description

Although gallium nitride high electron mobility transistors (GaN HEMTs) with ohmic pGaN gate like Infineon's 600 V CoolGaN™ power switches are robust enhancement-mode ("normally-on") devices, they differ significantly from MOSFETs. The gate module is not isolated from the channel, but behaves like a diode with a forward voltage V_F of 3 to 4 V. Equivalent circuit and typical gate input characteristic are given in **Figure 2**. In the steady "on" state a continuous gate current is required to achieve stable operating conditions. The switch is "normally-off", but the threshold voltage V_{th} is rather low ($\sim +1$ V). This is why in certain applications a negative gate voltage $-V_N$, typically in the range of several volts, is required to safely keep the switch "off" (**Figure 2b**).

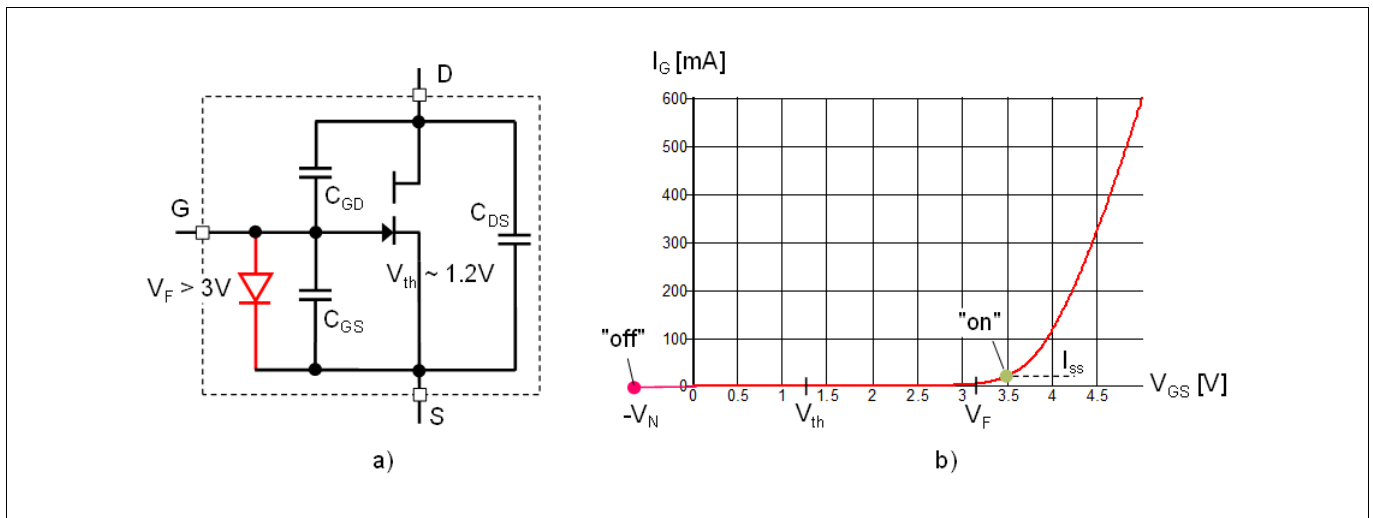

Figure 2 Equivalent circuit (a) and gate input characteristics (b) of typical normally-off GaN HEMT

Obviously the transistor in **Figure 2** cannot be driven like a conventional MOSFET due to the need for a steady-state "on" current I_{ss} and a negative "off" voltage $-V_N$. While an I_{ss} of a few mA is sufficient, fast switching transients require gate charging currents I_{on} and I_{off} in the 1 A range. To avoid a dedicated driver with 2 separate "on" paths and bipolar supply voltage, the solution depicted in **Figure 3** is usually chosen, combining a standard gate driver with a passive RC circuit to achieve the intended behavior. The high-current paths containing the small gate resistors R_{on} and R_{off} , respectively, are connected to the gate via a coupling capacitance C_C . C_C is chosen to have no significant effect on the dynamic gate currents I_{on} and I_{off} . In parallel to the high-current charging path the much larger resistor R_{ss} forms a direct gate connection to continuously deliver the small steady-state gate current, I_{ss} . In addition, C_C can be used to generate a negative gate voltage. Obviously, in the "on"-state C_C is charged to the difference of driver supply V_{DD0} and diode voltage V_F . When switching to the "off" state, this charge is redistributed between C_C and C_{GS} and causes an initial negative V_{GS} of value

(2.1)

$$-V_N = -\frac{C_C \cdot (V_{DD0} - V_F) - Q_{Geq}}{C_C + C_{GS}}$$

with Q_{Geq} denoting an equivalent application-specific gate charge, i.e. $Q_{Geq} \sim Q_{GS}$ for hard-switching and $Q_{Geq} \sim Q_{GS} + Q_{GD}$ for soft-switching transitions. V_N can thus be controlled by proper choice of V_{DD0} and C_C . During the "off" state the negative V_{GS} decreases, as C_C is discharged via R_{ss} . The associated time constant cannot be chosen independently, but is related to the steady-state current and is typically in the 1 μ s range. The negative gate voltage at the end of the "off" phase (V_{Nf} in **Figure 3b**) thus depends on the "off" duration. It lowers the effective driver voltage for the following switching "on" event, resulting in a dependence of switching dynamics on frequency and duty cycle as one drawback of this approach.

Background and system description

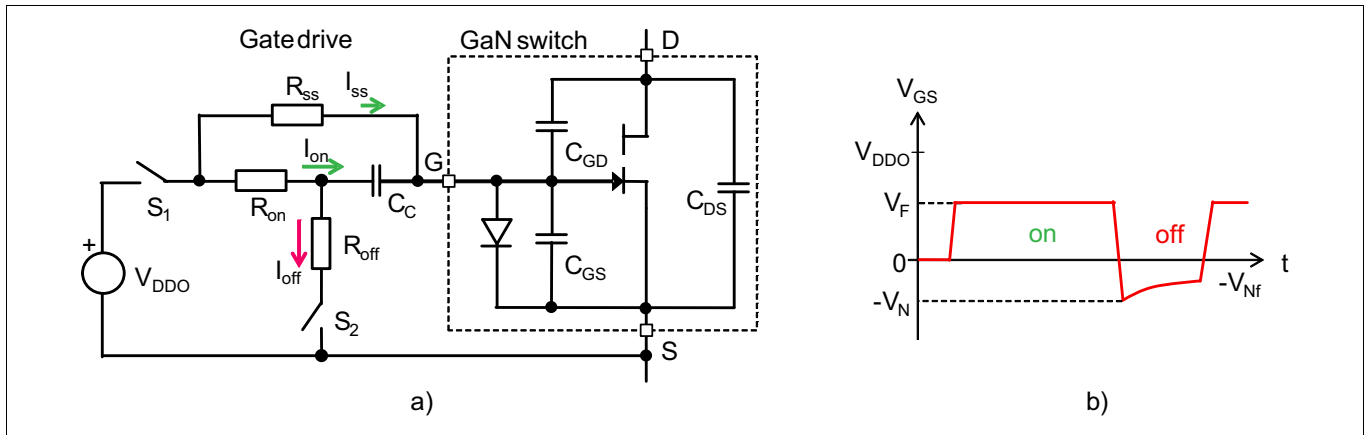

Figure 3 Equivalent circuit of GaN switch with RC gate drive (a) and gate-to-source voltage V_{GS} (b)

A second problem might happen if two switches are used alternately in a half-bridge configuration. In normal operation always one of the switches is "on", and before switching on the other one, it has to be switched off, thereby generating the negative gate voltage V_{Nf} . The usually short period with both switches "off" (dead time t_d) does not cause a significant increase of V_{GS} . If, however, there is by any reason a longer period with both switches in "off" state (e.g. during system start-up, burst mode operation etc.), both coupling capacitors (C_C) will be discharged. Thus, for the first switching pulse after such an extended non-switching period no negative voltage is available. This could lead to increased transistor stress or even instabilities due to spurious turn-on effects in half-bridge topologies.

To solve the problems described above, a shape of V_{GS} like the one in Figure 4b) would be required rather than the one in Figure 4a) which results from the simple RC circuit. As explained, a negative V_{GS} might be needed for safe "off" states during the switching transients, but it should be as low as possible. Due to the lack of a physical body diode any negative V_{GS} adds to the voltage drop of a GaN transistor in reverse polarity (diode operation) thereby increasing the conduction losses during dead time. Thus in the idealized waveform of Figure 4b) V_{GS} is switched to the minimum required V_N for a constant time t_1 longer than the system dead time t_d . After that V_{GS} is switched back to zero to ensure identical conditions for the next switch "on" event and to minimize losses from diode operation. If, however, an "off" state lasts for a time t_2 significantly longer than a normal switching period $1/f_{sw}$ (e.g. several μs), V_{GS} should be switched again to $-V_{Df}$ to avoid the described "first pulse" problem.

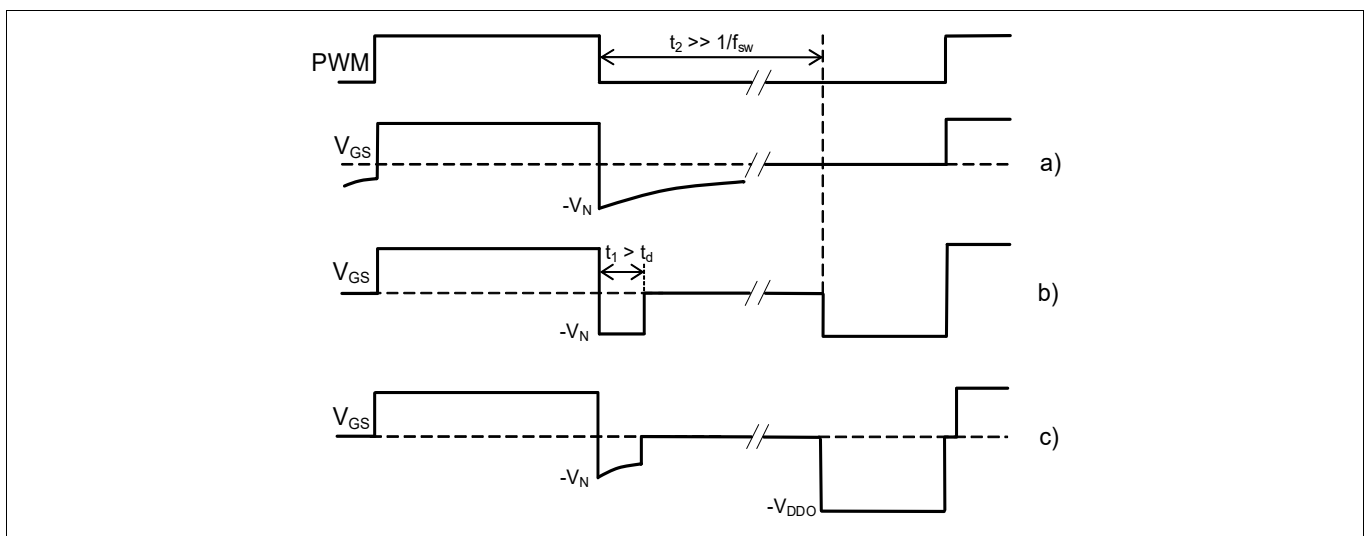

Figure 4 V_{GS} voltage waveforms with RC circuit (a), improved (b) and proposed shape (c)

Background and system description

The conceptual goal of the GaN EiceDRIVER™ is to provide the gate voltage of **Figure 4b)** or a functional equivalent without significantly increasing driving complexity. This is achieved by slightly modifying the gate drive waveform as depicted in **Figure 4c)**. The "off" level after a long deadtime need not be the optimized negative voltage $-V_N$, it could also be the more negative level $-V_{DDO}$. As these "first pulse" situations happen very rarely compared with regular switching cycles, the resulting higher reverse voltage drop has negligible effect on switching losses.

Although going from the 3-level signal of **Figure 4b)** to the 4 levels of **Figure 4c)** seems to increase complexity at first sight, this is finally not true. Waveform c) can be realized in a very convenient way, if V_N is generated by the RC network as described above. Then the differential driver concept of **Figure 5a)** with switch control signals as given in **Figure 5b)** is able to fulfil all discussed requirements with lowest effort: a single supply voltage, 4 switches and 4 connection pins are sufficient.

As mentioned, utilizing $-V_{DDO}$ instead of $-V_N$ only during extended "off"-phases has no impact on switching losses. However, care has to be taken when switching on again, because C_C is fully charged to V_{DDO} in this "first pulse" situation and no current flow is possible via the capacitive path. With the standard switching-on scheme (open S_1 / close S_2) the transient current thus would be limited to the small steady-state current. To achieve a faster turn-on, C_{GS} will be discharged prior to the "on"-transient by switching on S_3 for a short time t_3 before initiating the actual "on"-transient via S_1 and S_2 . A t_3 -duration of typically 20 ns is sufficient.

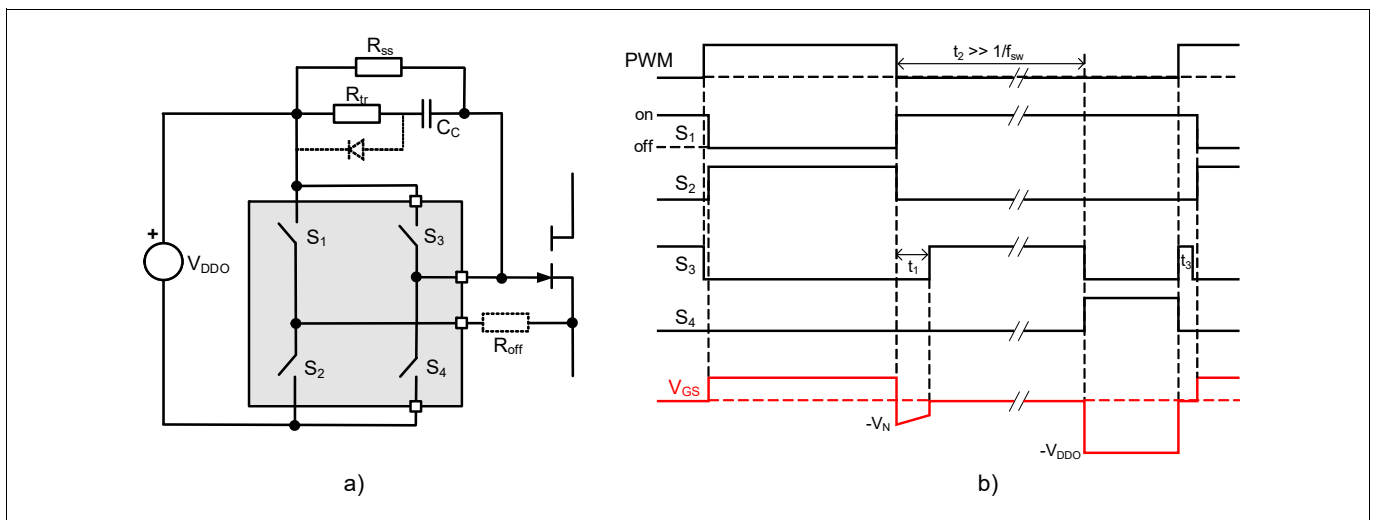

Figure 5 GaN EiceDRIVER™ concept (a) and switch control signals (b)

In the topology of **Figure 5a)** a single resistor R_{tr} is responsible for setting the maximum transient charging and discharging current. This is often acceptable. If it is not, an additional resistor R_{off} with series diode in parallel with R_{tr} can be used to realize different impedances for "on" and "off" transients, respectively. All relevant driving parameters are thus easily programmable by choosing V_{DDO} , R_{ss} , R_{tr} , R_{off} and C_C according to **Equation (2.1)** and the relations

(2.2)

$$I_{ss} = \frac{V_{DDO} - V_F}{R_{ss}}, \quad I_{on,max} = \frac{V_{DDO}}{R_{tr} + R_{off}}, \quad I_{off,max} = \frac{V_{th} + V_N}{R_{off}}$$

3 Functional description

3.1 Block diagram

A simplified functional block diagram of the GaN EiceDRIVER™ is given in **Figure 6**. The 4 output transistors are placed on 2 separate dies. Isolation between input and outputs is achieved by means of two coreless transformer structures (CT) situated on the input die.

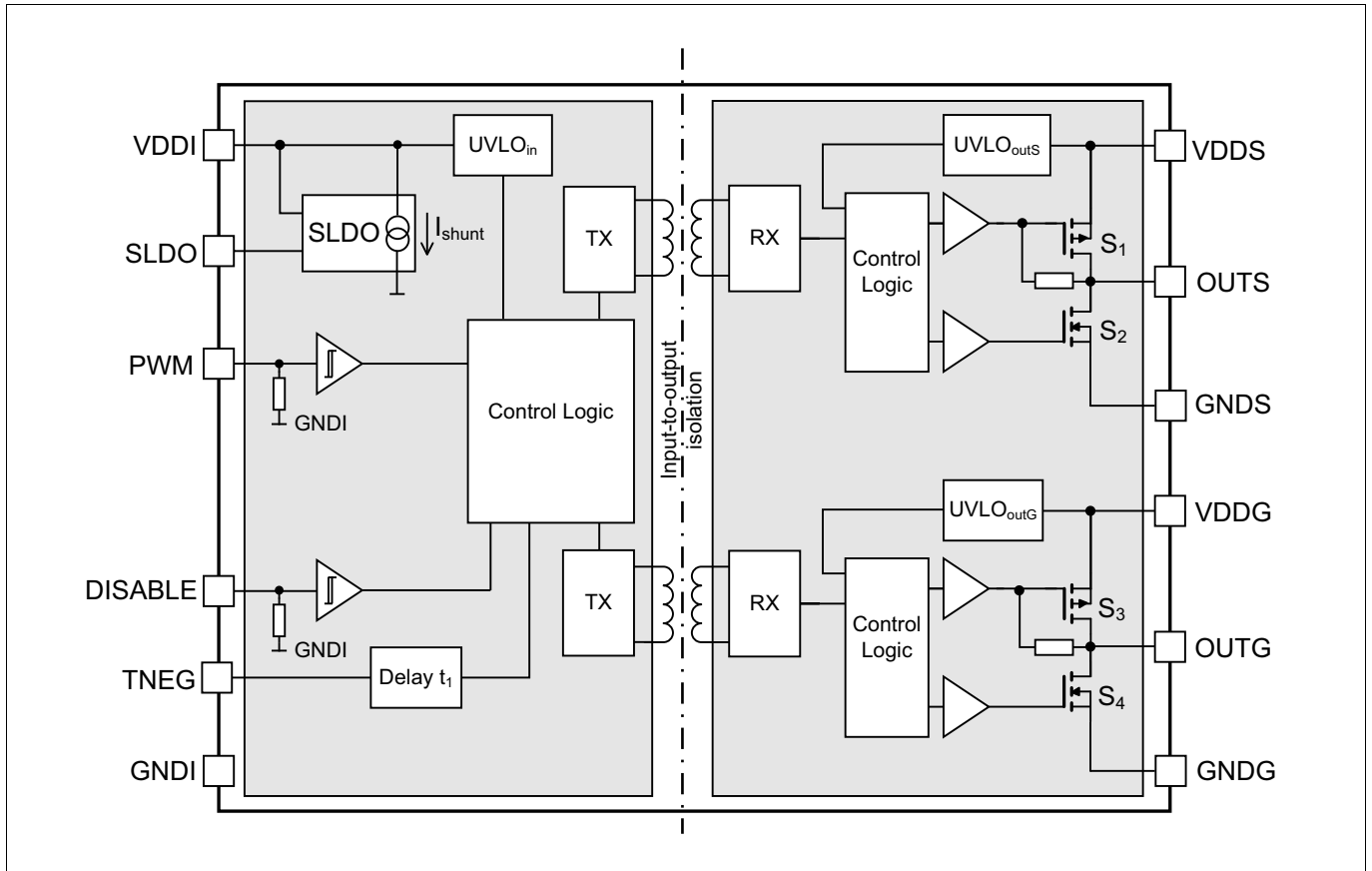

Figure 6 Block diagram

3.2 Isolation

The GaN EiceDRIVER™ is available in three package versions in accordance with different classes of input-to-output isolation voltage requirements

- 1EDF5673K in LGA-13 5 x 5 mm package for functional isolation (1.5 kV)
- 1EDF5673F in DSO-16 narrow-body (150 mil) package for functional isolation (1.5 kV)
- 1EDS5663H in DSO-16 wide-body (300 mil) package for reinforced isolation

In SMPS functional isolation is typical for high-voltage systems that are controlled from their primary side, whereas high-voltage switches controlled from the secondary side require safe isolation.

The safe isolation version 1EDS5663H is tested according to VDE0884-10 standards as specified in **Table 15** to **Table 18**. As the CT forming this barrier is placed on the input die, a true "fail-safe" isolation is achieved, i.e. even in case of a destruction of the power switch the driver input remains safely isolated from the output.

Functional description

3.3 Power supply

Due to the isolation between input and output side, two power domains with independent power management are required. Undervoltage Lockout (UVLO) functions for both input and output supplies ensure a defined start-up and robust functionality under all operating conditions.

3.3.1 Input supply voltage

The input die is supplied via VDDI with a nominal voltage of 3.3 V. Power consumption to some extent depends on switching frequency, as the input signal is converted into a train of repetitive current pulses to drive the coreless transformer. Due to the chosen robust encoding scheme the average repetition rate of these pulses and thus the average supply current depends on the switching frequency f_{sw} . However, for $f_{sw} < 500$ kHz this effect is very small.

The input side can also be operated with supply voltages higher than 3.3 V. Then a shunt LDO voltage regulator (SLDO) is enabled by connecting pin SLDO to GND. The SLDO regulates the current through an external resistor R_{VDDI} connected between the external supply voltage VDD and pin VDDI as depicted in the typical application circuit on [Page 1](#) to generate the required voltage drop. For proper operation it has to be ensured that the current through R_{VDDI} always exceeds the maximum supply current $I_{VDDI,max}$ of the input chip. R_{VDDI} thus has to fulfil

(3.1)

$$R_{VDDI} < \frac{V_{DD} - 3.3V}{I_{VDDI,max}}$$

Then I_{shunt} , the excess current through R_{VDDI} , can be controlled by the SLDO to regulate V_{DDI} to a constant 3.3 V. A typical choice for $V_{DD} = 5$ V could be $R_{VDDI} = 470 \Omega$, resulting in sufficient margin between resistor current and maximum average operating current. As usual, the dynamic peak current is provided by a blocking cap (10 to 22 nF) between V_{DDI} and GNDI.

3.3.2 Output supply voltage

Both output dies and the respective output switches are supplied by a common voltage of typically 8 V between pins VDDS/G and GNDS/G. A ceramic bypass capacitance in the 20 to 100 nF range has to be placed close to the supply pins. The output supply must be floating with respect to the input supply system. This is not only required by the Kelvin source connection of the GaN switch (results in inductive voltage peaks between input and output ground during switching transient), but also by the differential driving concept as explained in [Chapter 2](#).

Again the minimum operating supply voltage is set by an undervoltage lockout function (UVLO_{out}), operating independently of the input UVLO function.

3.3.3 Power dissipation

The main power components associated with gate drive are the following: as usual, a first small part (< 20 mW) is due to the internal driver supply currents I_{VDDI} and I_{VDDO} ; they slightly depend on switching frequency via the CT encoding scheme (see [Typical characteristics](#) in [Chapter 6](#)). The second component results from charging the gate capacitance and is in the same range due to the low gate charge of GaN switches.

However, there are 2 more GaN-specific power components. The continuous gate current any CoolGaN™ switch requires in the steady on-state causes some tens of mW to be dissipated. And, as a consequence of the differential driving concept, additional power is dissipated during longer non-switching periods; this is associated with the application of V_{DDO} as negative gate-to-source voltage, because V_{DDO} is then loaded directly with R_{SS} (see [Figure 5](#)). In burst-mode operation the power depends on the burst/pause ratio and is typically also only a few tens of mW. During extended stand-by modes, however, powering down the V_{DDO} supply could save about

GaN EiceDRIVER™ product family

GaN gate driver

Functional description

100 mW. It should also be pointed out that the internal gate/source clamp implemented in CoolGaN™ is connected in parallel with R_{SS} in this state. To avoid any significant additional current and power dissipation, V_{DDO} should be strictly limited to a maximum of 12 V.

As a summary, the total gate-drive power always stays in the 50 to 150 mW range and is thus sufficiently small to not cause any critical on-chip temperature increase.

3.4 Driver outputs

The rail-to-rail driver output stage realized with complementary MOS transistors is able to provide a typical 4 A sourcing and 8 A sinking current. Although these current levels are neither needed nor reached when driving GaN HEMTs (due to their low gate charge of only a few nC), the low on-resistance coming together with high driving current is nevertheless beneficial. With an R_{on} of 0.85 Ω for the sourcing pMOS and 0.35 Ω for the sinking nMOS transistor the driver can be considered as a nearly ideal switch. The gate drive parameters can thus be determined easily and accurately by the external components as described in [Chapter 2](#). The p-channel sourcing transistor enables real rail-to-rail behavior without suffering from the voltage drop unavoidably associated with nMOS source follower stages.

3.5 Undervoltage Lockout (UVLO)

The Undervoltage Lockout function ensures that the outputs can be switched only, if both input and output supply voltages exceed the corresponding UVLO threshold voltages. Thus it can be guaranteed, that the switch transistors are not operated, if the driving voltage is too low for complete and fast switching on, thereby avoiding excessive power dissipation.

The UVLO levels for the output supply are set to a typical "on" value of 4.5 and 5.5 V (with 0.3 V hysteresis) for OUTG and OUTS, respectively, whereas $UVLO_{in}$ for V_{DDI} is set to 2.85 V with 0.15 V hysteresis. The different UVLO levels for OUTG and OUTS help to safely avoid any erroneous turn-on of the GaN switch despite the low GaN threshold voltage. Special attention has been paid to cover all possible operating conditions, like start-up or arbitrary supply voltage situations:

- if V_{DDI} drops below $UVLO_{in}$, a "switch-to-low" command is sent to output OUTG, whereas OUTS is switched to "high"; this corresponds to the final state in extended "off" periods with $V_{GS} = -V_{DDO}$
- for V_{DD} lower than the output UVLO levels, an effective clamping concept has been realized by means of 100 k Ω resistors connecting the outputs OUTS and OUTG to the respective gates of the sourcing pMOS transistors in the output stage

As a result, safe operation of the GaN switch can be guaranteed under any circumstances.

3.6 CT communication and data transmission

A coreless transformer (CT) based communication module is used for PWM signal transfer between input and outputs. A proven high-resolution pulse repetition scheme in the transmitter combined with a watchdog time-out at the receiver side enables recovery from communication fails and ensures safe system shut-down in failure cases.

Besides, the repetition scheme is also used to signal a "first pulse" situation ([Figure 5](#)). If an "off"-state lasts longer than 32 μ s, the repetition rate of the CT pulses is reduced to a value that causes the watchdog on the output chip to wake up and initiate a change in the "off" state acc. to [Figure 5](#) (switch S_3 to "off" and S_4 to "on" state).

3.7 Signal timing

From the above, the extended "off"-phase t_2 defining a "first pulse" situation, is fixed at a typical value of 32 μ s. The other important timing parameter t_1 , i.e. the duration of the negative "off"-voltage, can be programmed by

GaN EiceDRIVER™ product family

GaN gate driver

Functional description

a resistor R_{t1} connected from TNEG to GNDI according to $t_1 = R_{t1} * 10.8 \text{ pF}$. As the main idea is to keep the switch in a safe "off" state during the switching transient, t_1 must be longer than the system dead time t_d , i.e. the maximum time both switches in a half-bridge are in "off" state. The upper limit for t_1 obviously is the minimum "off"-period; within these limits ($t_d < t_1 < t_{\text{off,min}}$), the actual t_1 value is completely uncritical without any effect on switching dynamics.

The above condition refers to systems with a fixed dead-time (complementary high-side and low-side control signals). In topologies with non-complementary signals (TCM PFC, active clamp flyback converter, burst mode operation) it cannot always be fulfilled. Then a limited number of "first pulse" situations may occur. However, as this typically happens in resonant topologies at low current values, the safe operating area of the switch is usually not exceeded.

Electrical characteristics

4 Electrical characteristics

4.1 Absolute maximum ratings

The absolute maximum ratings are listed in **Table 3**. Stresses beyond these values may cause permanent damage to the device. Exposure to absolute maximum rating conditions for extended periods may affect device reliability.

Table 3 Absolute maximum ratings

Parameter	Symbol	Values			Unit	Note or Test Condition
		Min.	Typ.	Max.		
Input supply voltage	V_{DDI}	-0.3	-	4.0	V	SLDO inactive (N.C. or connected to VDDI)
Output supply voltage	V_{DDO}	-0.3	-	22	V	-
Voltage at pins PWM and DISABLE	V_{IN}	-0.3	-	17	V	-
		-5	-	-	V	< 50 ns for transient ¹⁾
Voltage at pins TNEG and SLDO	V_{TNEG}	-0.3	-	$V_{DDI} + 0.3$	V	-
	V_{SLDO}					
Voltage at pins OUTS, OUTG	$V_{OUTS/G}$	-0.3	-	$V_{DDO} + 0.3$	V	-
		-2	-	$V_{DDO} + 1.5$	V	< 200 ns ¹⁾
Reverse current peak at pins OUTS, OUTG	I_{SRC_rev}	-5	-	-	A_{pk}	< 500 ns ¹⁾
	I_{SNK_rev}	-	-	5	A_{pk}	
Non-destructive Common Mode Transient Immunity	CMTI	400	-	-	V/ns	outputs with respect to input
Junction temperature	T_J	-40	-	150	°C	-
Storage temperature	T_{STG}	-65	-	150	°C	-
Soldering temperature	T_{SOL}	-	-	260	°C	reflow/wave soldering ²⁾
ESD capability	V_{ESD_CDM}	-	-	0.5	kV	Charged Device Model (CDM) ³⁾
ESD capability	V_{ESD_HBM}	-	-	2	kV	Human Body Model (HBM) ⁴⁾

1) parameter verified by design, not tested in production

2) according to JESD22A111

3) according to ANSI/ESDA/JEDEC JS-002

4) according to ANSI/ESDA/JEDEC JS-001

Electrical characteristics

4.2 Thermal characteristics

Table 4 Thermal characteristics at $T_A = 25^\circ\text{C}$

Parameter	Symbol	Values			Unit	Note or Test Condition
		Min.	Typ.	Max.		
PG-TFLGA-13-1 package						
Thermal resistance junction-ambient ¹⁾	R_{thJA25}	–	112	–	K/W	–
Thermal resistance junction-case (top) ²⁾	R_{thJC25}	–	44	–	K/W	–
Thermal resistance junction-board ³⁾	R_{thJB25}	–	66	–	K/W	–
Characterization parameter junction-top ⁴⁾	Ψ_{thJT25}	–	7.7	–	K/W	–
Characterization parameter junction-board ⁴⁾	Ψ_{thJB25}	–	5.6	–	K/W	–
PG-DSO-16-30 package						
Thermal resistance junction-ambient ¹⁾	R_{thJA25}	–	59	–	K/W	–
Thermal resistance junction-case (top) ²⁾	R_{thJC25}	–	32	–	K/W	–
Thermal resistance junction-board ³⁾	R_{thJB25}	–	33	–	K/W	–
Characterization parameter junction-top ⁴⁾	Ψ_{thJT25}	–	8.9	–	K/W	–
Characterization parameter junction-board ⁴⁾	Ψ_{thJB25}	–	7.7	–	K/W	–
PG-DSO-16-11 package						
Thermal resistance junction-ambient ¹⁾	R_{thJA25}	–	51	–	K/W	–
Thermal resistance junction-case (top) ²⁾	R_{thJC25}	–	25	–	K/W	–
Thermal resistance junction-board ³⁾	R_{thJB25}	–	36	–	K/W	–
Characterization parameter junction-top ⁴⁾	Ψ_{thJT25}	–	4.4	–	K/W	–
Characterization parameter junction-board ⁴⁾	Ψ_{thJB25}	–	5.4	–	K/W	–

- 1) obtained by simulating a JEDEC-standard, high-K board, as specified in JESD51-7, in an environment described in JESD51-2a.
- 2) obtained by simulating a cold plate test on the package top. No specific JEDEC standard test exists, but a close description can be found in the ANSI SEMI standard G30-88.
- 3) obtained by simulating an environment with a ring cold plate fixture to control the PCB temperature, as described in JESD51-8.
- 4) estimates the junction temperature of a device in a real system and is extracted from the simulation data for obtaining R_{th} , using a procedure described in JESD51-2a (sections 6 and 7).

Electrical characteristics

4.3 Operating range

Table 5 Operating range

Parameter	Symbol	Values			Unit	Note or Test Condition
		Min.	Typ.	Max.		
Input supply voltage	V_{DDI}	3	–	3.5	V	SLDO inactive (N.C. or connected to VDDI)
Output supply voltage	V_{DDO}	6.5	8	20 ¹⁾	V	Min. defined by UVLO
VDDI blocking capacitance	C_{VDDI}	–	–	22	nF	SLDO active (connected to GNDI)
Resistor defining t_1	R_{t1}	3	18	45	k Ω	–
Logic input voltage at pins PWM and DISABLE	V_{IN}	0	–	6.5	V	–
Voltage at pins SLDO	V_{SLDO}	0	–	3.5	V	–
Junction temperature	T_J	-40	–	150 ²⁾	$^{\circ}\text{C}$	
Ambient temperature	T_A	-40	–	125	$^{\circ}\text{C}$	–

1) for CoolGaN™ HEMTs $V_{DDO} < 12\text{ V}$ is recommended

2) continuous operation above 125 $^{\circ}\text{C}$ may reduce lifetime

4.4 Electrical characteristics

Unless otherwise noted, min./max. values of characteristics are the lower and upper limits, respectively. They are valid within the full operating range. Typical values are given at $T_J = 25^{\circ}\text{C}$ with $V_{DDI} = 3.3\text{ V}$ and $V_{DDO} = 8\text{ V}$

Table 6 Power supply

Parameter	Symbol	Values			Unit	Note or Test Condition
		Min.	Typ.	Max.		
VDDI quiescent current	I_{VDDIqu}	–	1.5	–	mA	no switching
VDDO quiescent current	I_{VDDOqu}	–	1.3	–	mA	no switching

Table 7 Static output characteristics

Parameter	Symbol	Values			Unit	Note or Test Condition
		Min.	Typ.	Max.		
High level (sourcing) output resistance	R_{on_SRC}	0.42	0.85	1.6	Ω	$I_{SRC} = 50\text{ mA}$
Peak sourcing output current	I_{SRC_pk}	–	4	¹⁾	A	–
Low level (sinking) output resistance	R_{on_SNK}	0.18	0.35	0.75	Ω	$I_{SNK} = 50\text{ mA}$
Peak sinking output current	I_{SNK_pk}	²⁾	-8	–	A	–

1) actively limited to approx. 5.2 A_{pk} , not subject to production test - verified by design / characterization

2) actively limited to approx. -10.2 A_{pk} , not subject to production test - verified by design / characterization

Electrical characteristics

Table 8 Dynamic characteristics, $T_{J,max} = 125^{\circ}\text{C}$ (see Figure 7 and Figure 8)

Parameter	Symbol	Values			Unit	Note or Test Condition
		Min.	Typ.	Max.		
PWM to OUTS propagation delay	t_{PDOnS}	31	37	44	ns	load between OUTS and GNDs $C_{LS} = 1.8 \text{ nF}$
	t_{PDOffS}	–	41	–		
PWM to OUTG propagation delay	t_{PDOnG}	–	$t_{PDOffS} + t_1$	–	ns	load between OUTG and GNDG $Z_{LG} = 1.8 \text{ nF} // 20 \Omega$
	t_{PDOffG}	31	37	44		
DISABLE to OUTS propagation delay	t_{PD_DISon}	–	–	100	ns	$C_{LS} = 1.8 \text{ nF}$
	t_{PD_DISoff}	–	–	–		
Rise time OUTS / OUTG	t_{rise}	–	6.5	12 ¹⁾	ns	$C_{LS} = C_{LG} = 1.8 \text{ nF}$, 10% to 90%
Fall time OUTS	t_{fall}	–	4.5	8 ¹⁾	ns	$C_{LS} = 1.8 \text{ nF}$, 90% to 10%
Minimum input pulse width that changes output state	t_{PW}	–	18	–	ns	–
Duration of negative gate “off” voltage	t_1	–	194	–	ns	$R_{t1} = 18 \text{ k}\Omega$
Minimum “off” time before entering “first pulse” mode	t_2	–	32 ¹⁾	–	μs	–
Discharging time in “first pulse” mode	t_3	–	20 ¹⁾	–	ns	–

1) verified by design, not tested in production

Table 9 Undervoltage Lockout

Parameter	Symbol	Values			Unit	Note or Test Condition
		Min.	Typ.	Max.		
Undervoltage Lockout input (UVLO _{in}) turn on threshold	UVLO _{in}	2.75	2.85	2.95	V	–
Undervoltage Lockout (UVLO _{in}) turn off threshold	UVLO _{in-}	–	2.7	–	V	–
UVLO _{in} threshold hysteresis	ΔUVLO_{in}	0.1	0.15	0.2	V	–
Undervoltage Lockout outputs (UVLO _{outG/S}) turn on threshold	UVLO _{outG}	4.7	5.0	5.3	V	–
	UVLO _{outS}	5.4	5.8	6.2		
UVLO _{out} turn off thresholds	UVLO _{outG-}	–	4.5	–	V	–
	UVLO _{outS-}	–	5.2	–	V	–
UVLO _{out} threshold hysteresis	ΔUVLO_{outG}	0.3	0.45	0.6	V	–
	ΔUVLO_{outS}	0.4	0.6	0.8		

Electrical characteristics

Table 10 Logic inputs PWM and DISABLE

Parameter	Symbol	Values			Unit	Note or Test Condition
		Min.	Typ.	Max.		
Input voltage threshold for transition LH	V_{INL}	1.7	2.0	2.3	V	independent of V_{DDI}
Input voltage threshold for transition HL	V_{INH}	–	1.2	–	V	independent of V_{DDI}
Input voltage hysteresis	ΔV_{IN}	0.4	0.8	1.2	V	–
Input pull down resistor	R_{IN}	–	150	–	k Ω	–

Timing diagrams

5 Timing diagrams

Figure 7 depicts rise, fall and delay times as observed at the capacitively loaded outputs OUTS and OUTG, resp. As OUTG is not actively switched to low, a resistor in parallel with the load capacitance has to be used for testing. In addition to the signal propagation delay t_{PDon} , the rising edge of OUTG is delayed by a time t_1 defining the duration of negative V_{GS} .

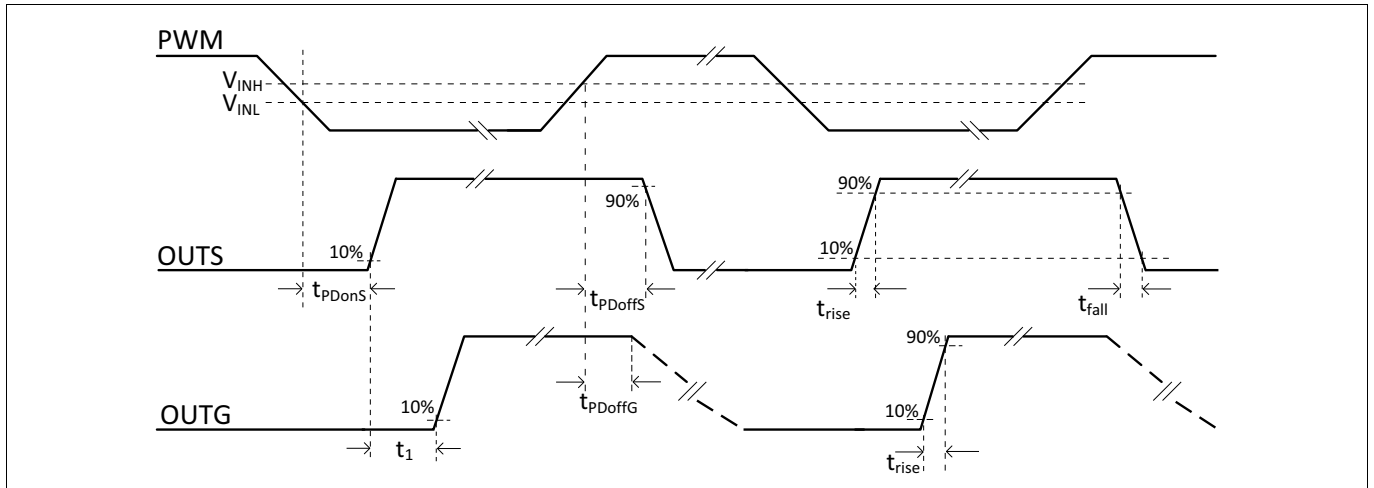

Figure 7 Propagation delay, rise and fall time

Figure 8 illustrates a complete switching sequence of the four switches forming the two output stages of GaN EiceDRIVER™ (delay, rise and fall times not shown). The sequence in the left part of **Figure 8** corresponds to the normal switching operation, whereas in the right part the "first pulse" situation is depicted. This situation is assumed to happen whenever there is no switching action for an extended period t_2 . Clearly t_2 must be significantly longer than a regular switching period. A typical duration of 32 μ s has been chosen, as GaN switches usually operate at switching frequencies significantly above 50 kHz (switching period below 20 μ s).

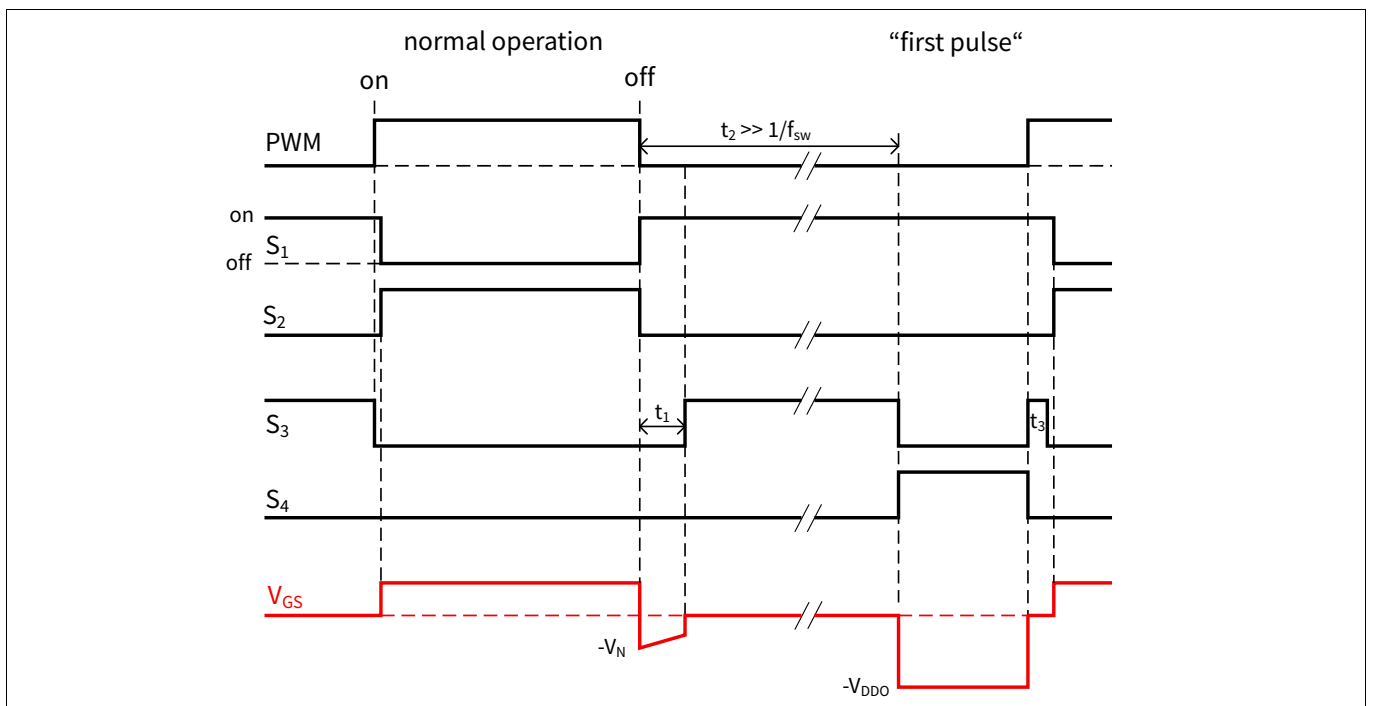

Figure 8 Input signal, output switch sequence and resulting V_{GS} for normal operation and "first pulse" situation

Typical characteristics

6 Typical characteristics

$V_{DD} = 8\text{ V}$, $V_{DDI} = 3.3\text{ V}$, $T_A = 25^\circ\text{C}$, no load (unless otherwise noted)

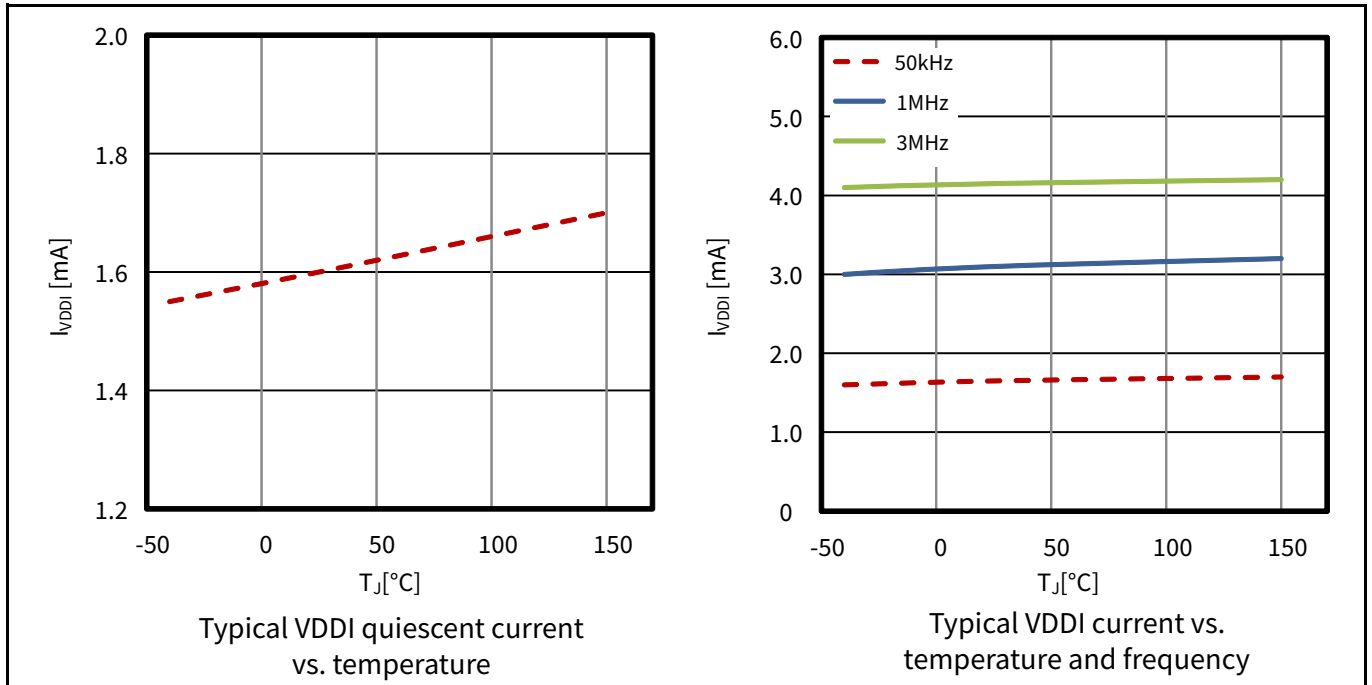

Figure 9 Supply current VDDI

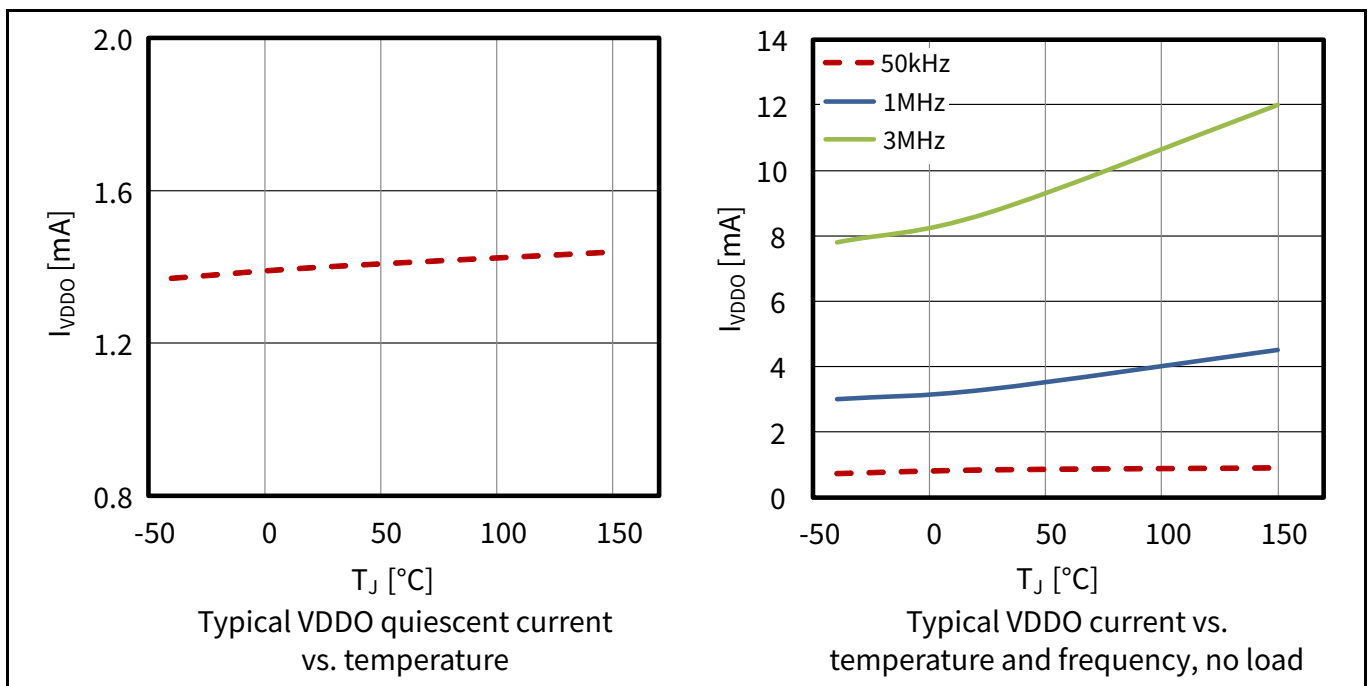

Figure 10 Supply current VDDO

Typical characteristics

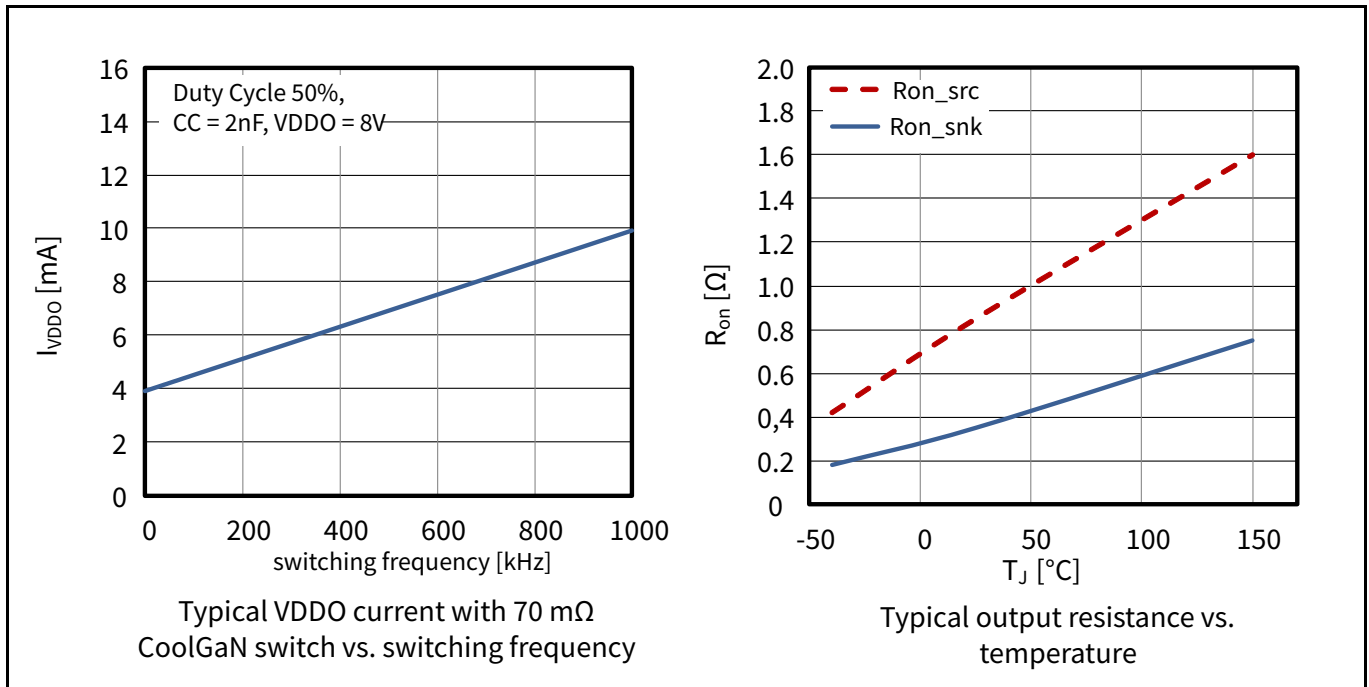

Figure 11 Supply current VDDO (with load) and output resistance

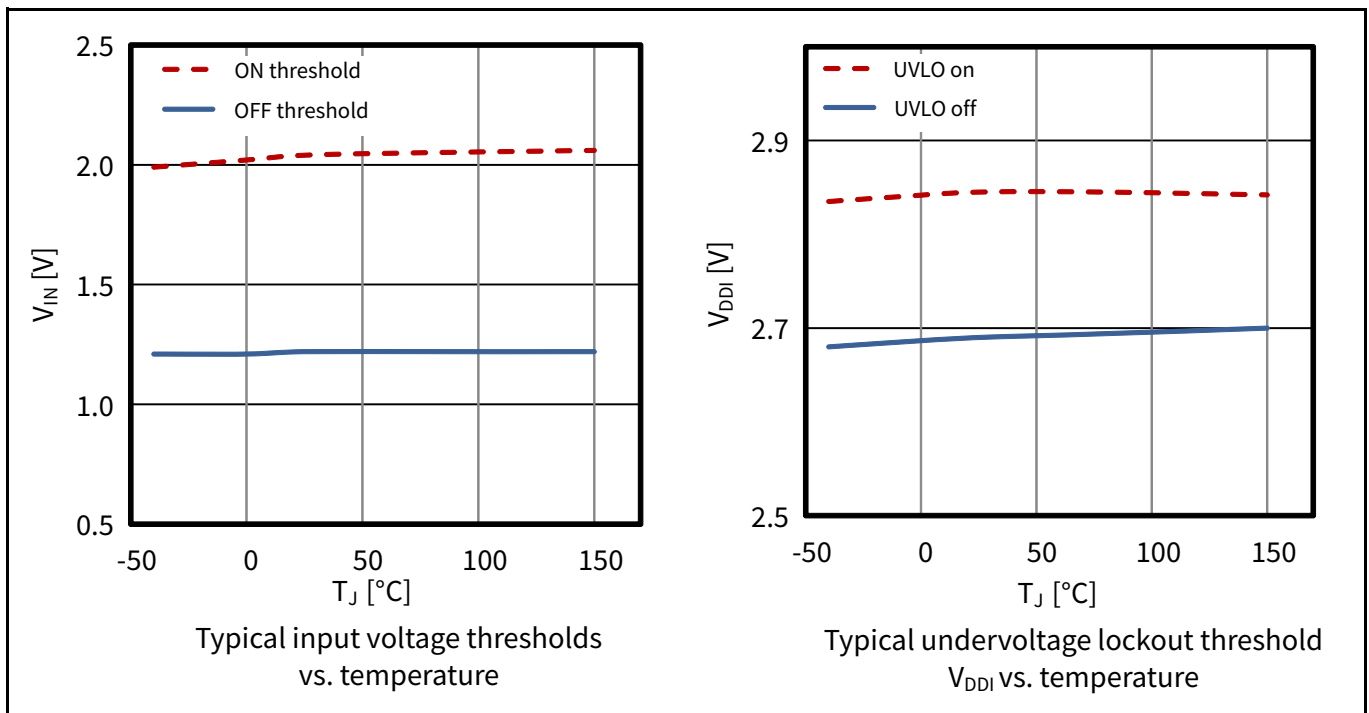

Figure 12 Logic input thresholds and V_{DDI} UVLO

Typical characteristics

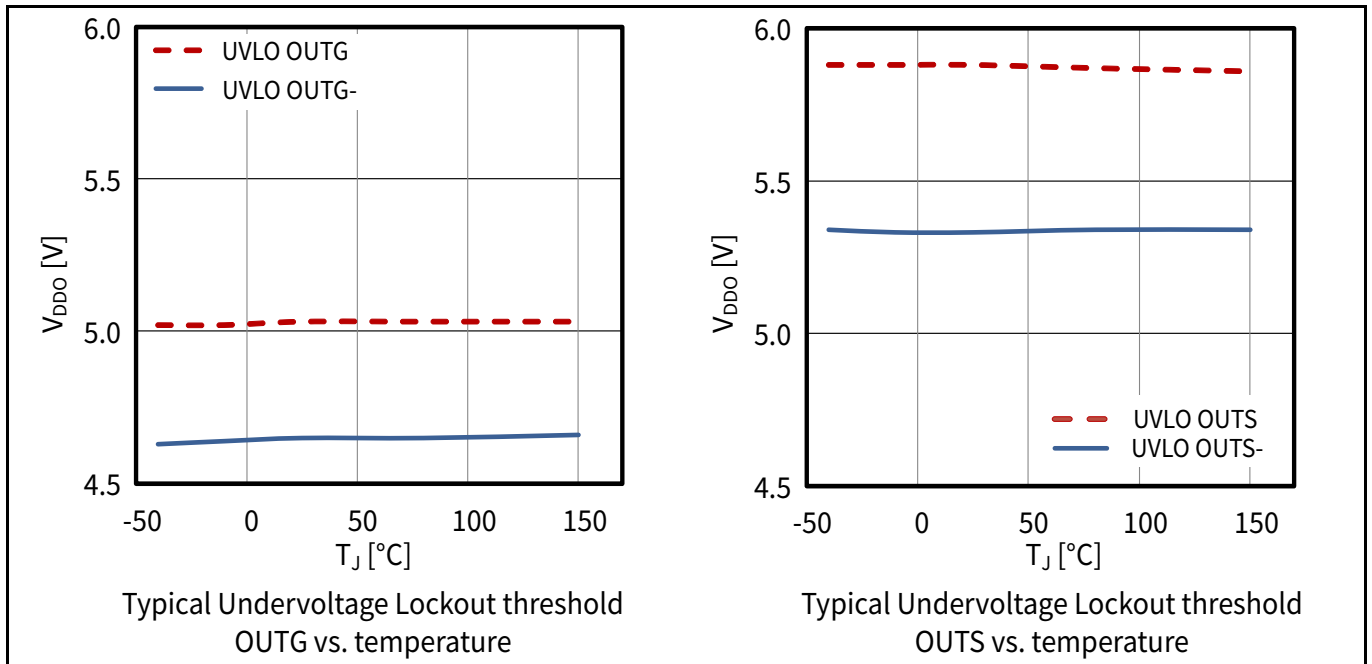

Figure 13 Output UVLO

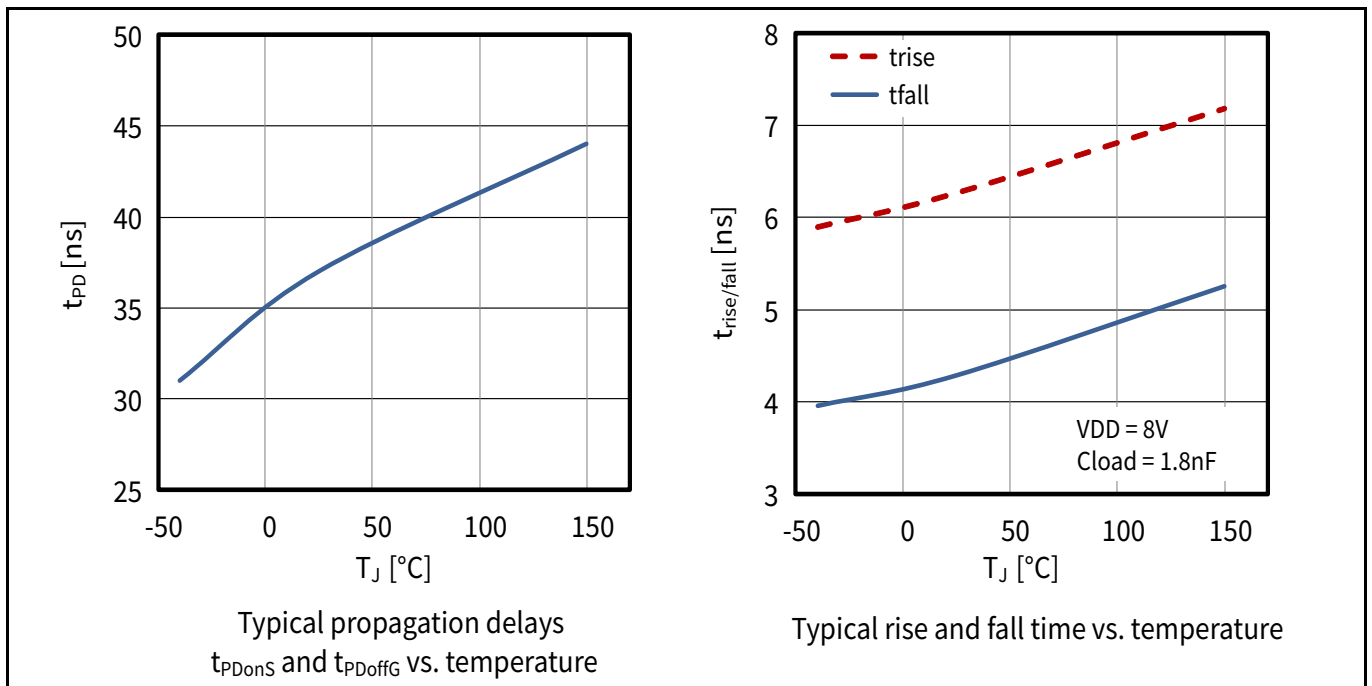

Figure 14 Propagation delay and rise / fall time

Typical characteristics

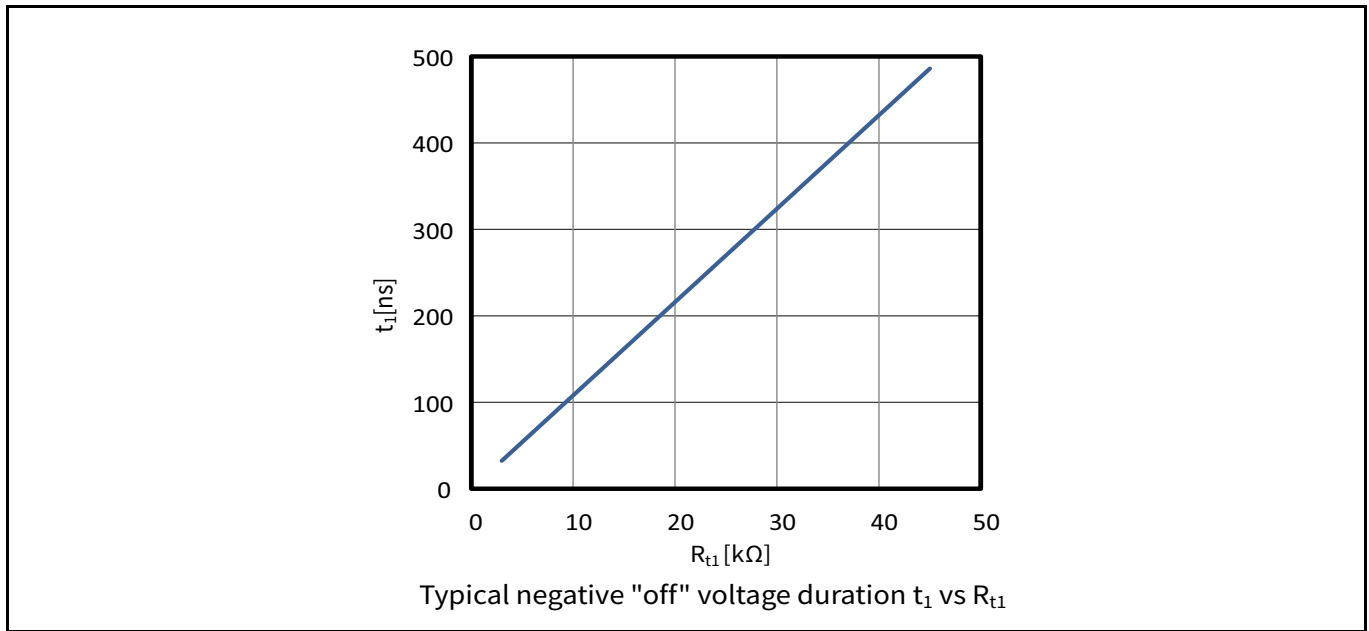

Figure 15 Typical negative "off" voltage duration t_1 vs. R_{t1}

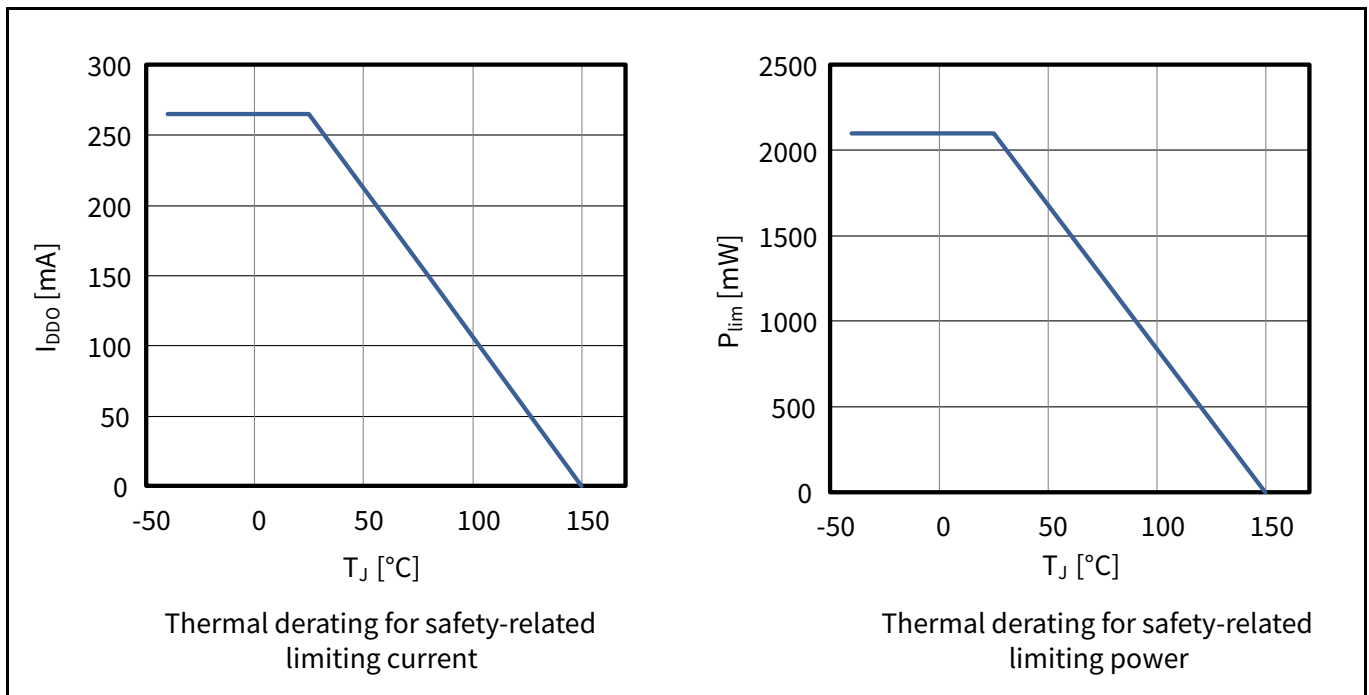

Figure 16 Thermal derating curves

Isolation specifications

7 Isolation specifications

The following tables summarize the package-specific isolation characteristics and test methods. For reinforced isolation, the regulatory tests described in the component and system standards are applied; functional isolation is guaranteed by the specified in-house test methods.

As soon as the regulatory certificates are available, the reference and / or documents will become available for public download on the Infineon website.

As finally creepage and clearance distances are influenced by PCB layout, it is the customer's responsibility to verify the respective requirements on system level.

7.1 Functional isolation specifications

7.1.1 Functional isolation in PG-TFLGA-13-1 package (1EDF5673K)

Table 11 Functional isolation input-to-output (PG-TFLGA-13-1)

Parameter	Symbol	Values			Unit	Note or Test Condition
		Min.	Typ.	Max.		
Functional isolation test voltage	V_{IO}	1500	–	–	V_{DC}	impulse test >10 ms, production tested
Maximum isolation working voltage	V_{IOWM}	460	–	–	V_{RMS}	according to IEC 60664-1 (PD 2; MG II)
Package clearance	CLR	–	3.4	–	mm	shortest distance over air, from any input pin to any output pin
Package creepage	CPG	–	3.4	–	mm	shortest distance over surface, from any input pin to any output pin
Common Mode Transient Immunity	CMTI	200	–	–	V/ns	according to VDE V0884-10, static and dynamic test
Capacitance input-to-output	C_{IO}	–	2	–	pF	–
Resistance input-to-output	R_{IO}	–	>1000	–	MΩ	–

Isolation specifications

Table 12 Package characteristics (PG-TFLGA-13-1)

Parameter	Symbol	Values			Unit	Note or Test Condition
		Min.	Typ.	Max.		
Comparative tracking Index of package mold	CTI	400	–	600	V	according to DIN EN 60112 (VDE 0303-11)
Material group	–	–	II	–	–	according to IEC 60112

7.1.2 Functional isolation in NB PG-DSO-16-11 package (1EDF5673F)

Table 13 Functional isolation input-to-output (NB PG-DSO-16-11)

Parameter	Symbol	Values			Unit	Note or Test Condition
		Min.	Typ.	Max.		
Functional isolation test voltage	V_{IO}	1500	–	–	V_{DC}	impulse test > 10 ms, sample tested
Maximum isolation working voltage	V_{IOWM}	510	–	–	V_{RMS}	according to IEC 60664-1 (PD2; MG II) ¹⁾
Package clearance	CLR	–	4.0	–	mm	shortest distance over air, from any input pin to any output pin
Package creepage	CPG	–	4.0	–	mm	shortest distance over surface, from any input pin to any output pin
Common Mode Transient Immunity	CMTI	200	–	–	V/ns	according to VDE V0884-10, static and dynamic test
Capacitance input-to-output ¹⁾	C_{IO}	–	2	–	pF	–
Resistance input-to-output ¹⁾	R_{IO}	–	>1000	–	MΩ	–

1) verified by design, not tested in production

Table 14 Package characteristics (NB PG-DSO-16-11)

Parameter	Symbol	Values			Unit	Note or Test Condition
		Min.	Typ.	Max.		
Comparative tracking Index of package mold	CTI	400	–	600	V	according to DIN EN 60112 (VDE 0303-11)
Material group	–	–	II	–	–	according to IEC 60112

Isolation specifications

7.2 Reinforced isolation in WB PG-DSO-16-30 package (1EDS5663H)

Table 15 Input-to-output isolation specification according to VDE0884-10 (WB PG-DSO-16-30)

Parameter	Symbol	Values			Unit	Note or Test Condition
		Min.	Typ.	Max.		
Maximum transient isolation voltage	V_{IOTM}	8000	–	–	V_{pk}	qualification for $t = 60$ s; production test with $V_{IOTM_test} = V_{IOTM} * 1.2$ for $t = 1$ s
Maximum repetitive peak isolation voltage	V_{IORM}	1420	–	–	V_{pk}	Time Dependent Dielectric Breakdown test method
Maximum isolation working voltage	V_{IOWM}	1420 1000	– –	– –	V_{DC} V_{RMS}	
Partial discharge voltage	V_{PD}	4500	–	–	V_{pk}	production test for $t = 1$ s, partial discharge $Q_{PD} < 5$ pC
Maximum surge isolation voltage	V_{IOSM}	6250	–	–	V_{pk}	$V_{IOSM_test} = 1.6 \times V_{IOSM} > 10$ kV _{pk} ; sample tested ¹⁾
Package clearance	CLR	–	8.0	–	mm	from any input pin to any output pin
Package creepage	CPG	–	8.0	–	mm	from any input pin to any output pin
Overvoltage category per IEC 60664-1 table F.1	–	I	–	IV		rated mains voltage $\leq 150 V_{RMS}$
		I	–	III		$\leq 300 V_{RMS}$
		I	–	II		$\leq 600 V_{RMS}$
Capacitance input-to-output	C_{IO}	–	2	–	pF	–
Resistance input-to-output	R_{IO}	–	>1000	–	M Ω	–
Common Mode Transient Immunity	CMTI	200	–	–	V/ns	input to output static and dynamic; sample test

1) surge pulse tests applied according to IEC60065-10.1 (Ed 8.0 2014), 61000-4-5, 60060-1 waveforms (1.2 μ s slope, 50 μ s decay)

Table 16 Reinforced isolation package characteristics (WB PG-DSO-16-30)

Parameter	Symbol	Values			Unit	Note or Test Condition
		Min.	Typ.	Max.		
Comparative Tracking Index of package mold	CTI	400	–	600	V	according to DIN EN 60112 (VDE 0303-11)
Material group	–	–	II	–	–	according to IEC 60112
Pollution degree	–	–	2	–	–	–
Climatic category	–	–	40/125/21	–	–	–

Isolation specifications

Table 17 Reinforced input-to-output isolation according to UL1577 Ed 5 (WB PG-DSO-16-30)

Parameter	Symbol	Values			Unit	Note or Test Condition
		Min.	Typ.	Max.		
Withstand isolation voltage	V_{ISO}	5700	–	–	V_{RMS}	$V_{ISO} = 5700 V_{RMS}$ for $t = 60$ s (qualification); $V_{ISO_test} > 1.2 \times V_{ISO} = 6840$ V for $t = 1$ s

7.3 Safety-limiting values

Table 18 Reinforced isolation safety-limiting values as outlined in VDE-0884-10 (WB PG-DSO-16-30)

Parameter	Side	Values			Unit	Note or Test Condition
		Min.	Typ.	Max.		
Safety supply power	Input	–	–	20.0	mW	$R_{thJA} = 59$ K/W ¹⁾ , $T_A = 25^\circ\text{C}$, $T_J = 150^\circ\text{C}$
	Output	–	–	2100	mW	
	Total	–	–	2120	mW	
Safety supply current	Output	–	–	265	mA	$R_{thJA} = 59$ K/W ¹⁾ , $V_{DDO} = 8$ V, $T_A = 25^\circ\text{C}$, $T_J = 150^\circ\text{C}$
Safety temperature	T_s	–	–	150	°C	$T_s = T_{J,max}$

1) Calculated with the R_{th} of WB-DSO-16-30 package (see [Table 4](#))

According to VDE0884-10 and UL1577, safety-limiting values define the operating conditions under which the isolation barrier can be guaranteed to stay unaffected. This corresponds with the maximum allowed junction temperature, as temperature-induced failures might cause significant overheating and eventually damage the isolation barrier.

8 Application circuit

Figure 17 depicts a typical application for CoolGaN™ switches in a so-called "totem-pole" PFC. It consists of a 70 mΩ GaN half-bridge controlled by two GaN EiceDRIVERS; the diode functions indicated in the power path are usually realized with low- $R_{DS(ON)}$ MOSFETs operating as synchronous rectifiers. 2.5 kW of power can be handled at very high efficiency (above 99%).

The topology in **Figure 17** differs from standard PFCs mainly by the fact that both GaN transistors are used alternately in switch and diode operation mode, depending on the polarity of the input voltage. This eliminates the need for rectifying the input voltage and therefore avoids a significant loss contributor. Such a topology cannot be realized with MOS-switches due to their inherent body diode and the associated large recovery charge.

Further details can be found in application note: www.infineon.com/driving-coolgan

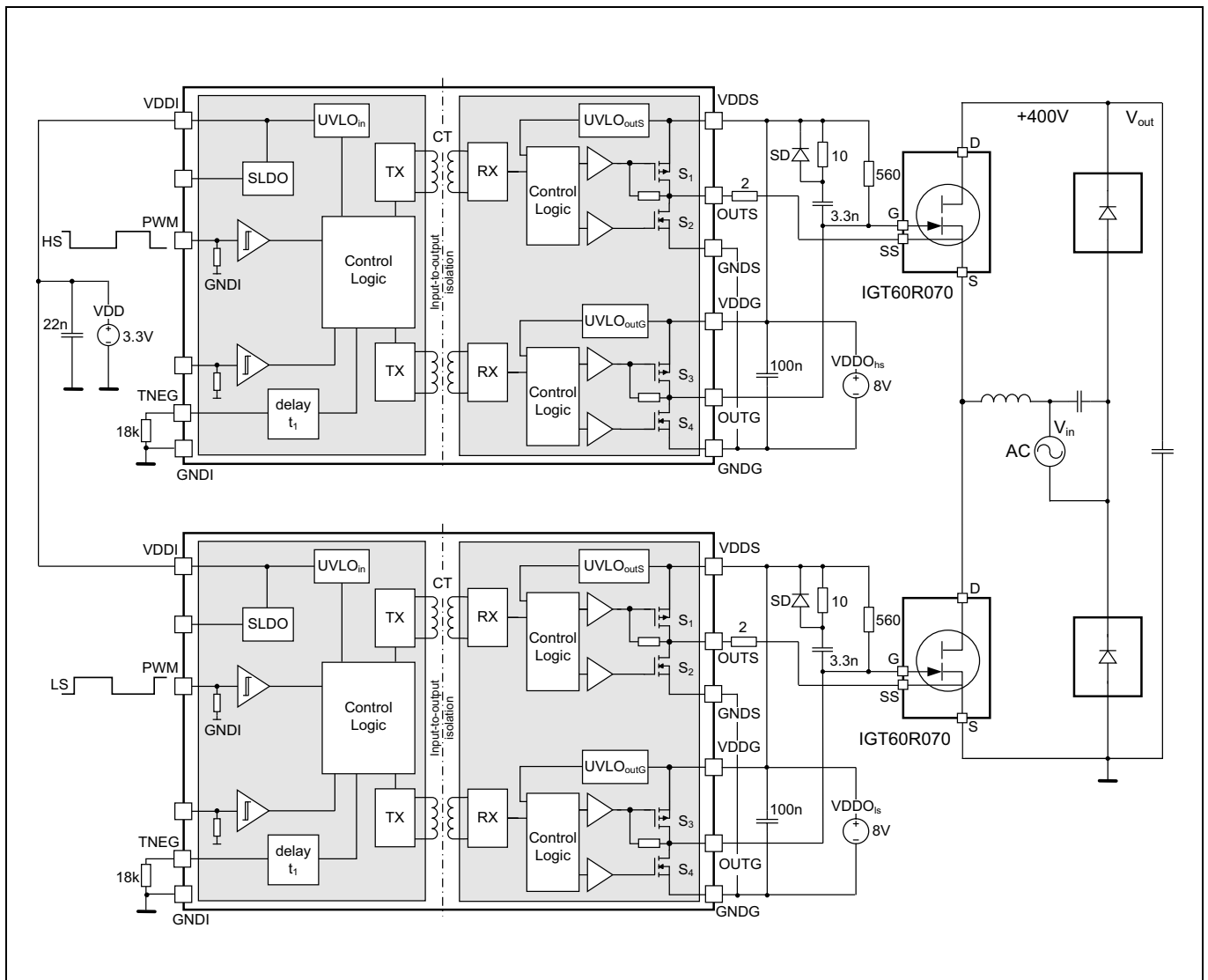

Figure 17 Typical application circuit for 2.5 kW GaN "totem-pole" PFC

8.1 Dimensioning guidelines

Due to low output impedance, high current limits and fast transients, the driver output stages can be regarded to behave like ideal switches. Thus half-bridge switching dynamics are exclusively and predictably controlled by the passive external components in the gate loop, allowing an easy adaptation to different applications and switch sizes.

GaN EiceDRIVER™ product family

GaN gate driver

Application circuit

As a first step in dimensioning these components the intended initial negative gate voltage $-V_N$ has to be defined. The correlation between V_N , V_{DDO} and C_C as given in Equation (2.1) is graphically depicted in Figure 18 for a hard-switched 70 mΩ CoolGaN™ transistor.

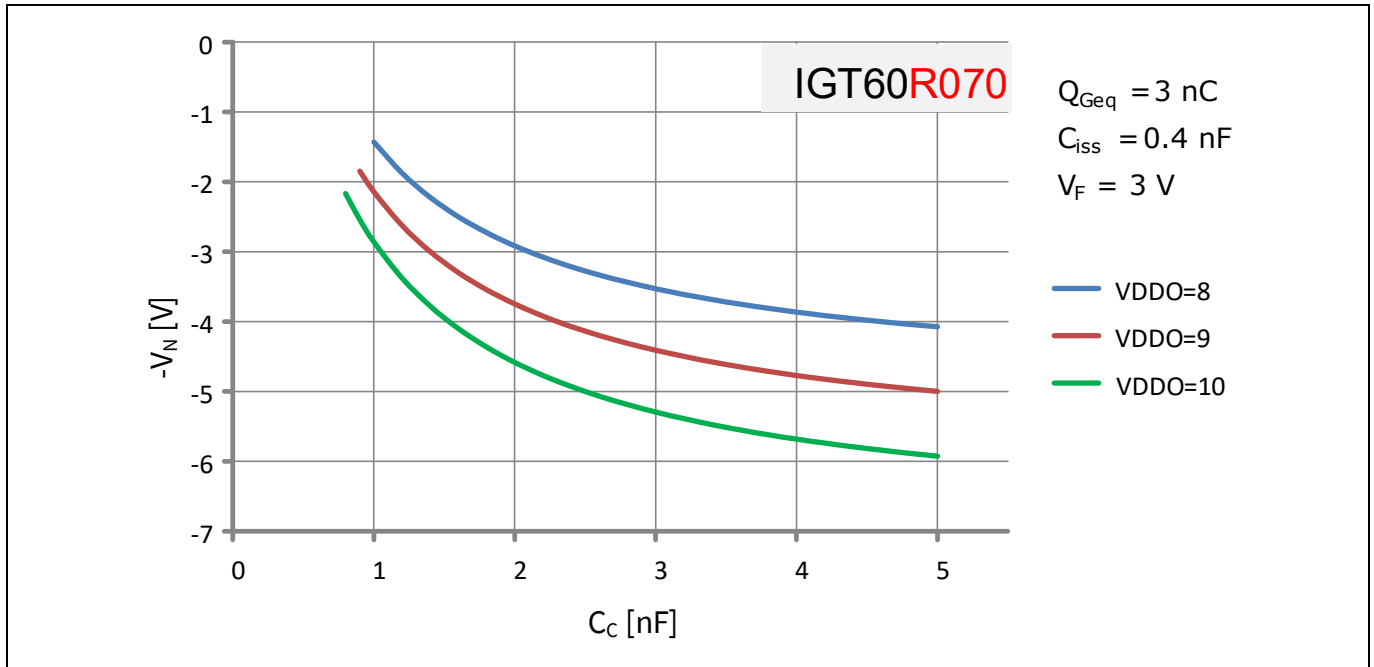

Figure 18 $-V_N$ as a function of V_{DDO} and C_C for hard-switched 70 mΩ CoolGaN™

A typical choice for $-V_N$ could be -4 V for hard-switched and -2 V for soft-switched applications, respectively. Additionally, due to the low GaN threshold voltage, even under worst-case conditions $-V_N$ should never be allowed to become positive. This requirement defines the minimum coupling capacitance C_{Cmin} . Under typical conditions C_{Cmin} then in fact generates a V_N of about 2 V, and thus this capacitance value can be recommended to be used in soft-switching topologies. Beside C_{Cmin} , Table 19 also summarizes recommended values for C_{Chs} , the coupling capacitance in hard-switching topologies, and resistor R_{SS} for different CoolGaN™ switches (currently 70 and 190 mΩ).

Table 19 Recommended values of C_{Cmin} , C_{Chs} and R_{SS}

V_{DDO} [V]	IGx60R070x (70 mΩ)			IGx60R190x (190 mΩ)		
	C_{Cmin} [nF]	C_{Chs} [nF]	R_{SS} [kΩ]	C_{Cmin} [nF]	C_{Chs} [nF]	R_{SS} [kΩ]
8	1.8	3.3	0.56	1	1.8	1.2
10	1.2	1.8	0.82	0.8	1	1.8

The application circuit of Figure 17 uses different gate resistors for the "on" and "off" gate loops by introducing resistor R_{off} and (Schottky-)diode SD. The values of R_{tr} and R_{off} define the respective peak gate currents and thus switching times according to Equation (2.2). Due to the basic trade-off between switching time and inductive voltage overshoot, parasitic power and gate loop inductances have a strong influence on the optimum values of the gate resistors. For a 70 mΩ CoolGaN™ switch they are typically in the 5 to 20 Ω range for R_{tr} , whereas 2 to 5 Ω are a reasonable choice for R_{off} .

Finally, also indicated in Figure 17, the 330 pF capacitance in parallel with resistor R_{t1} on the high-side helps to minimize the variation of t_1 as explained in Chapter 3.6.

GaN EiceDRIVER™ product family

GaN gate driver

Layout guidelines

9 Layout guidelines

For any fast-switching power system the PCB layout is crucial to achieve optimum performance. Among the many existing rules, recommendations, guidelines, tips and tricks, the following are of highest importance:

- minimize power loop inductance, the most critical limitation of switching speed due to the unavoidable voltage overshoots generated by fast current commutation
- use low-ESR decoupling capacitances for the driver supply voltages and place them as close as possible to the driver (in the layout proposals below the output capacitance has been split and connected to both supply pins)
- strictly avoid any additional coupling capacitance between input and output pins due to PCB layout (see [Chapter 3.7](#))

Respective layout proposals for the immediate driver surroundings are given in [Figure 19](#), [Figure 20](#) and [Figure 21](#) for the different available package types.

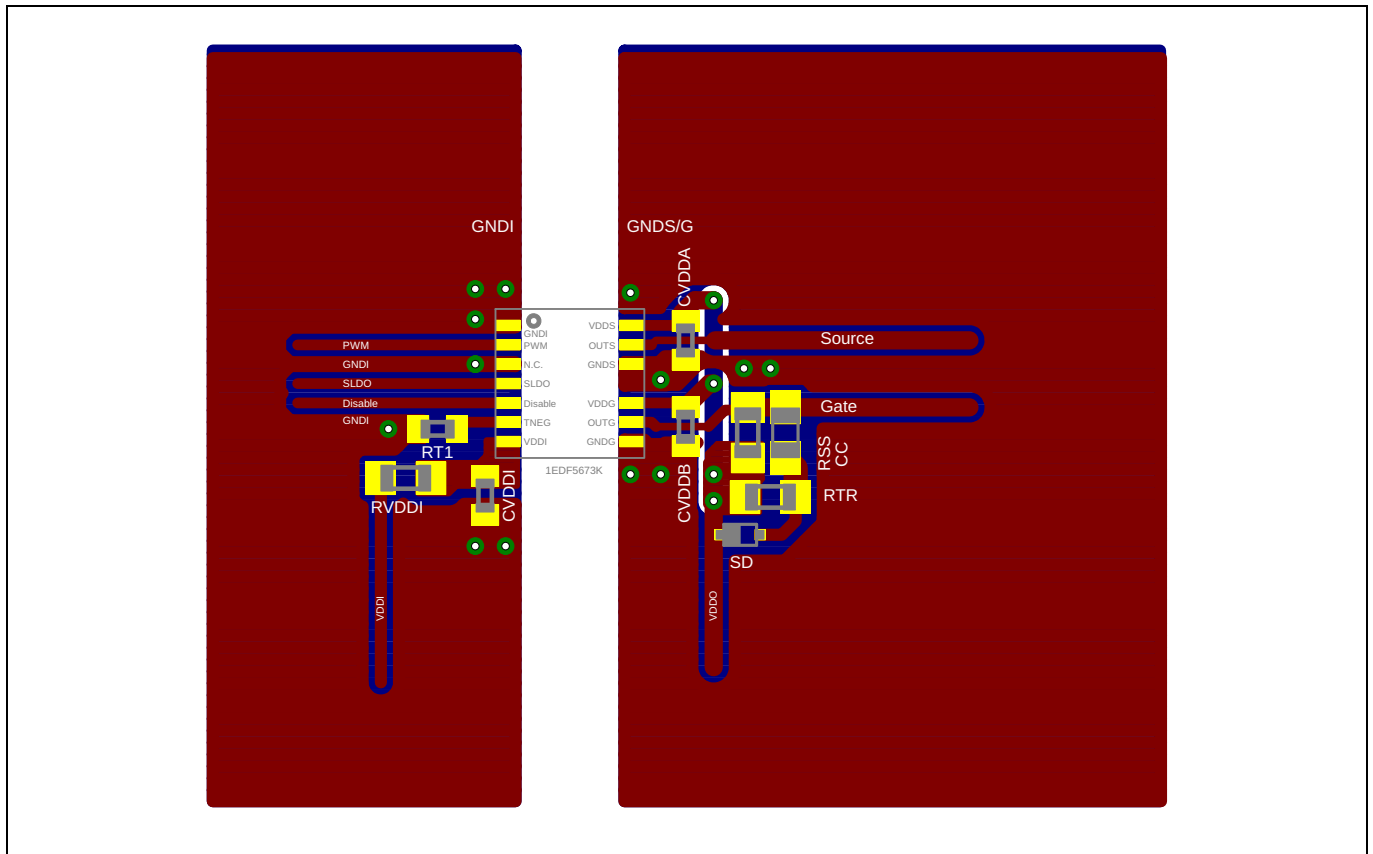

Figure 19 Layout recommendation for PG-TFLGA-13-1 package

GaN EiceDRIVER™ product family

GaN gate driver

Layout guidelines

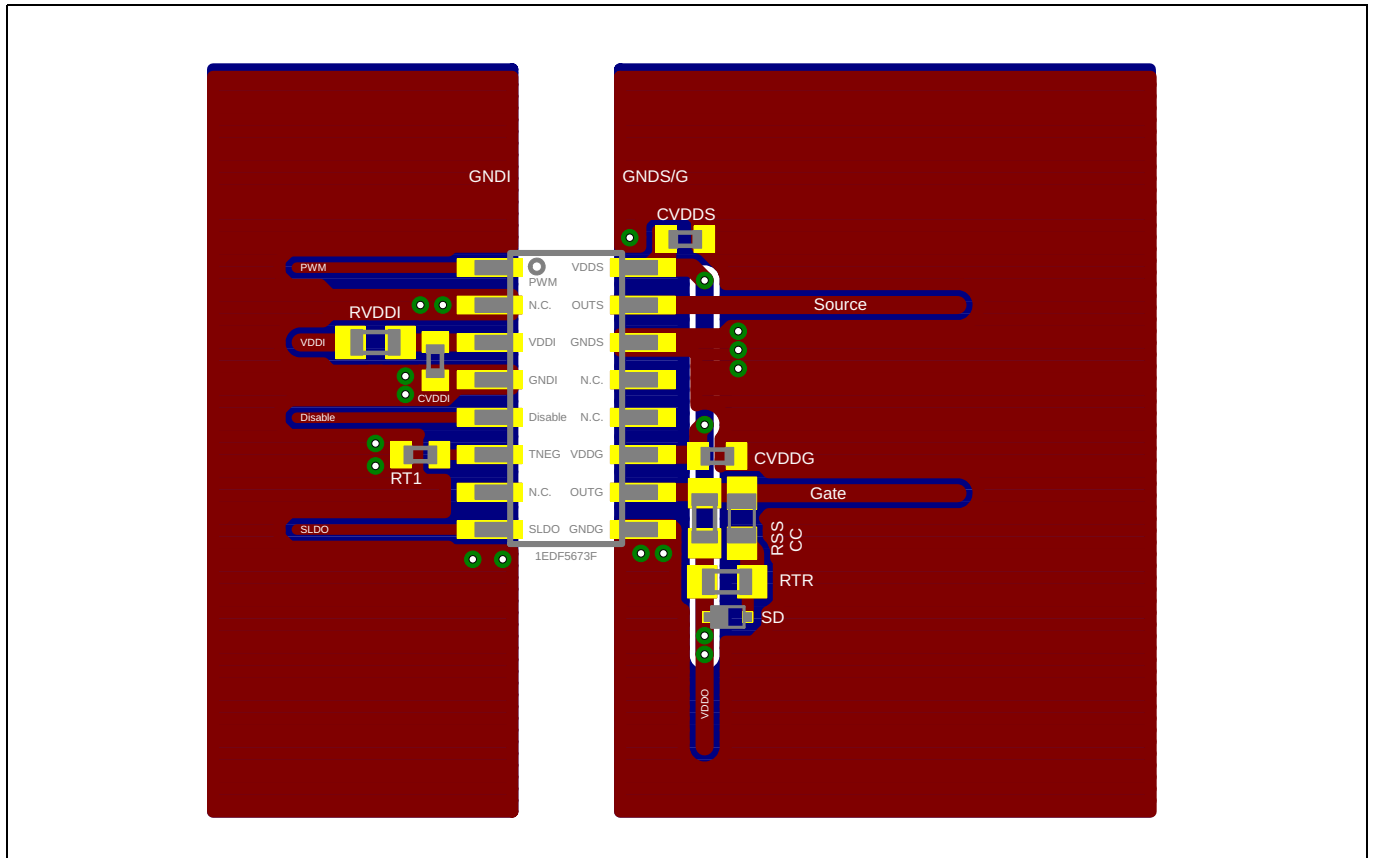

Figure 20 Layout recommendation for PG-DSO-16-11 package

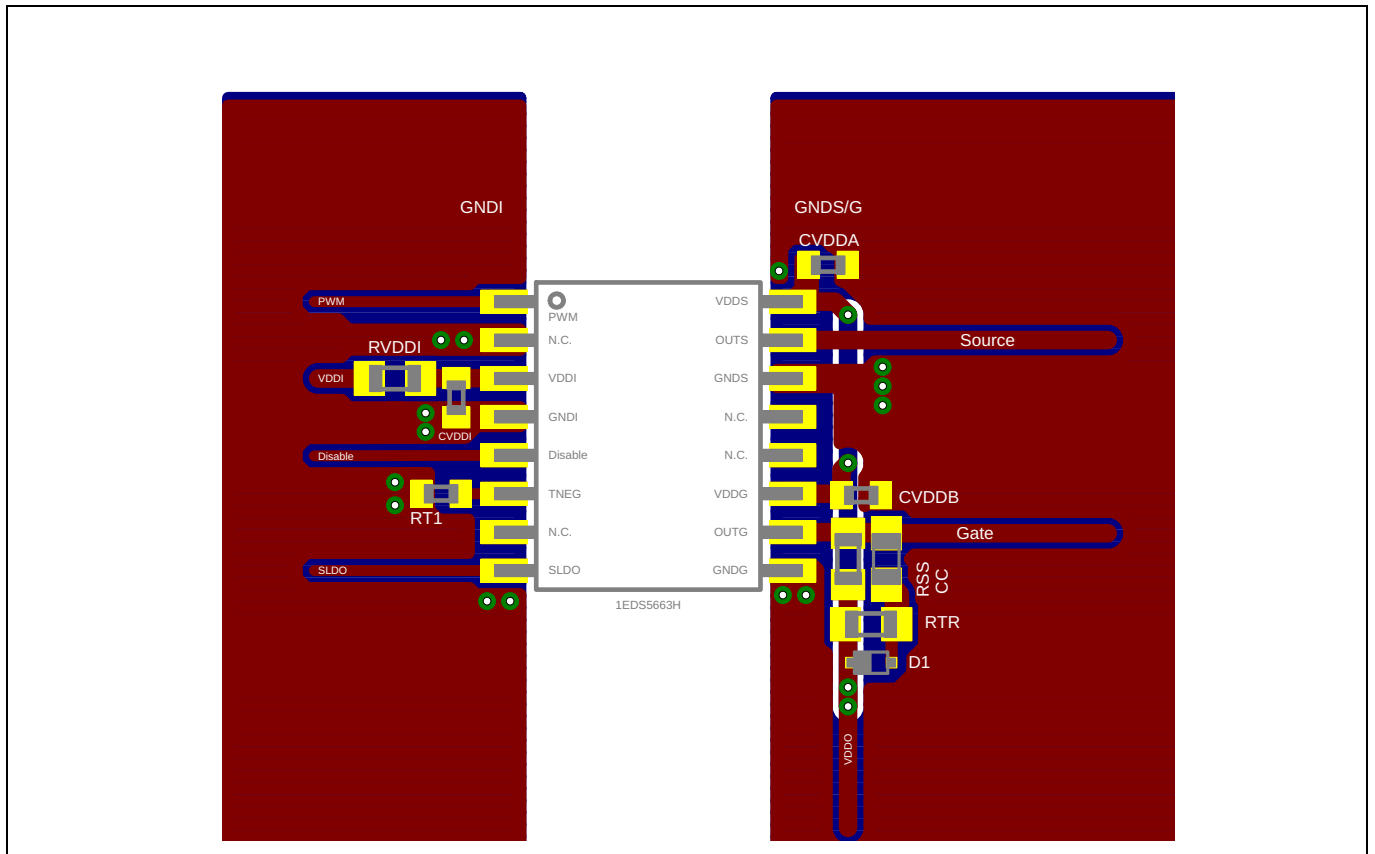

Figure 21 Layout recommendation for PG-DSO-16-30 package

GaN EiceDRIVER™ product family

GaN gate driver

Package outline dimensions

10 Package outline dimensions

The following package versions are available.

- an area optimized 5 x 5 mm² PG-TFLGA-13-1
- an NB PG-DSO-16-11 package with typ. 4 mm creepage input to output
- a WB PG-DSO-16-30 package with typ. 8 mm creepage input to output

Note: For further information on package types, recommendation for board assembly, please go to <https://www.infineon.com/packages>

10.1 Package PG-TFLGA-13-1

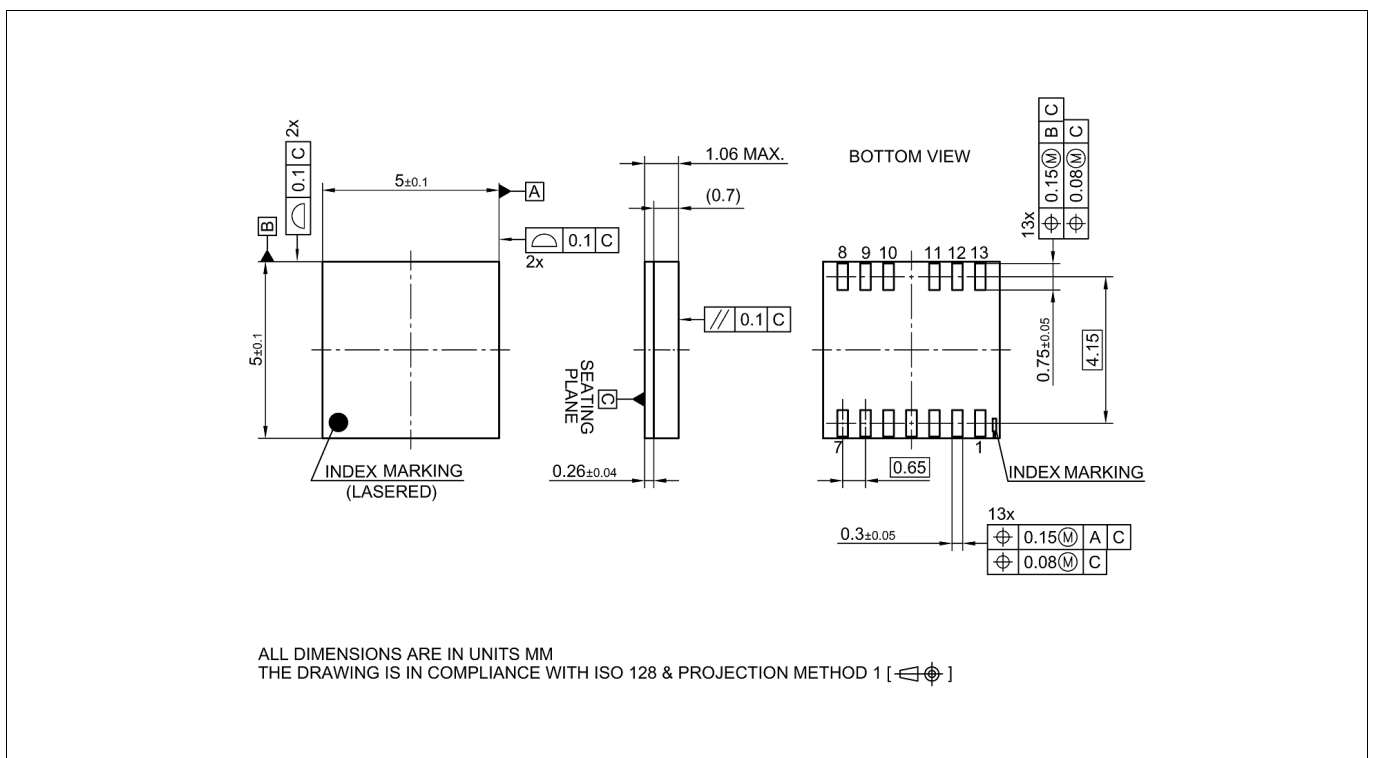

Figure 22 PG-TFLGA-13-1 outline

GaN EiceDRIVER™ product family

GaN gate driver

Package outline dimensions

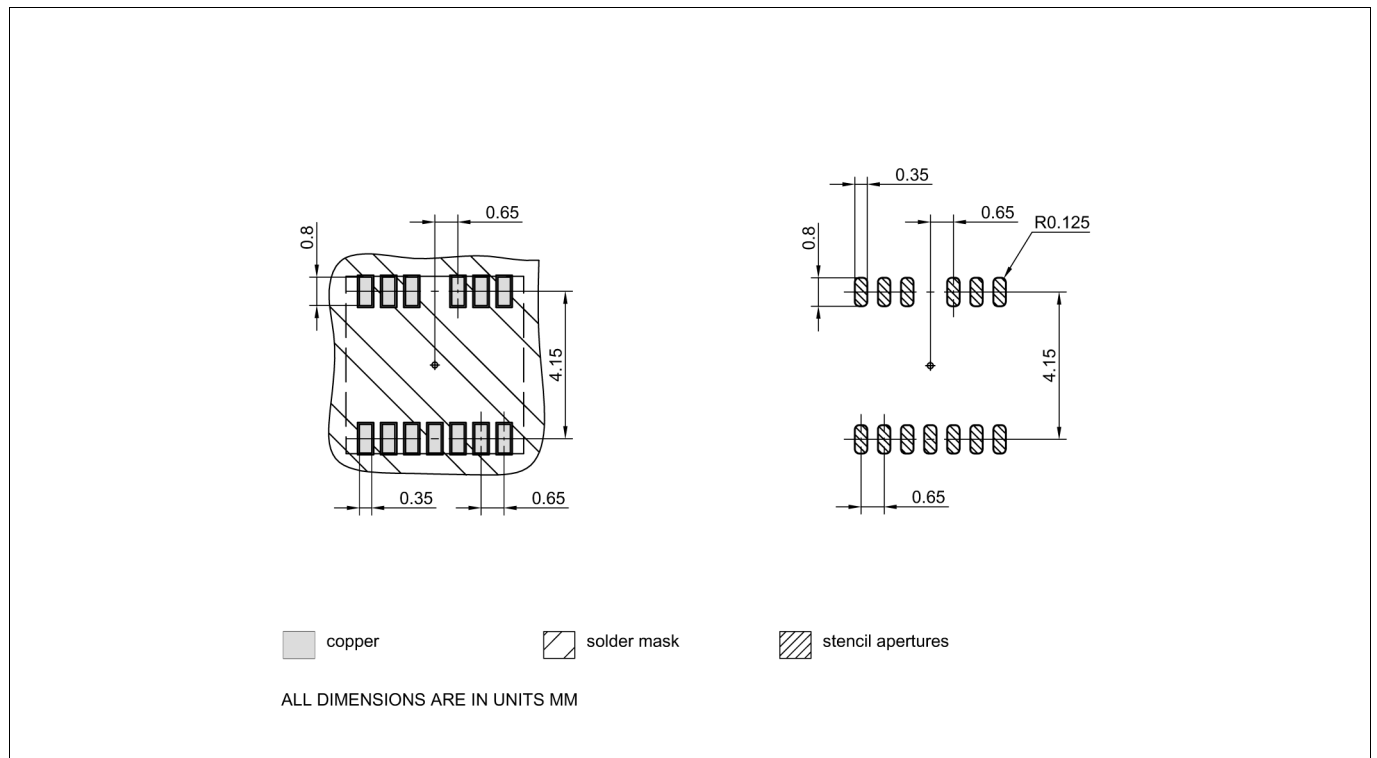

Figure 23 PG-TFLGA-13-1 footprint

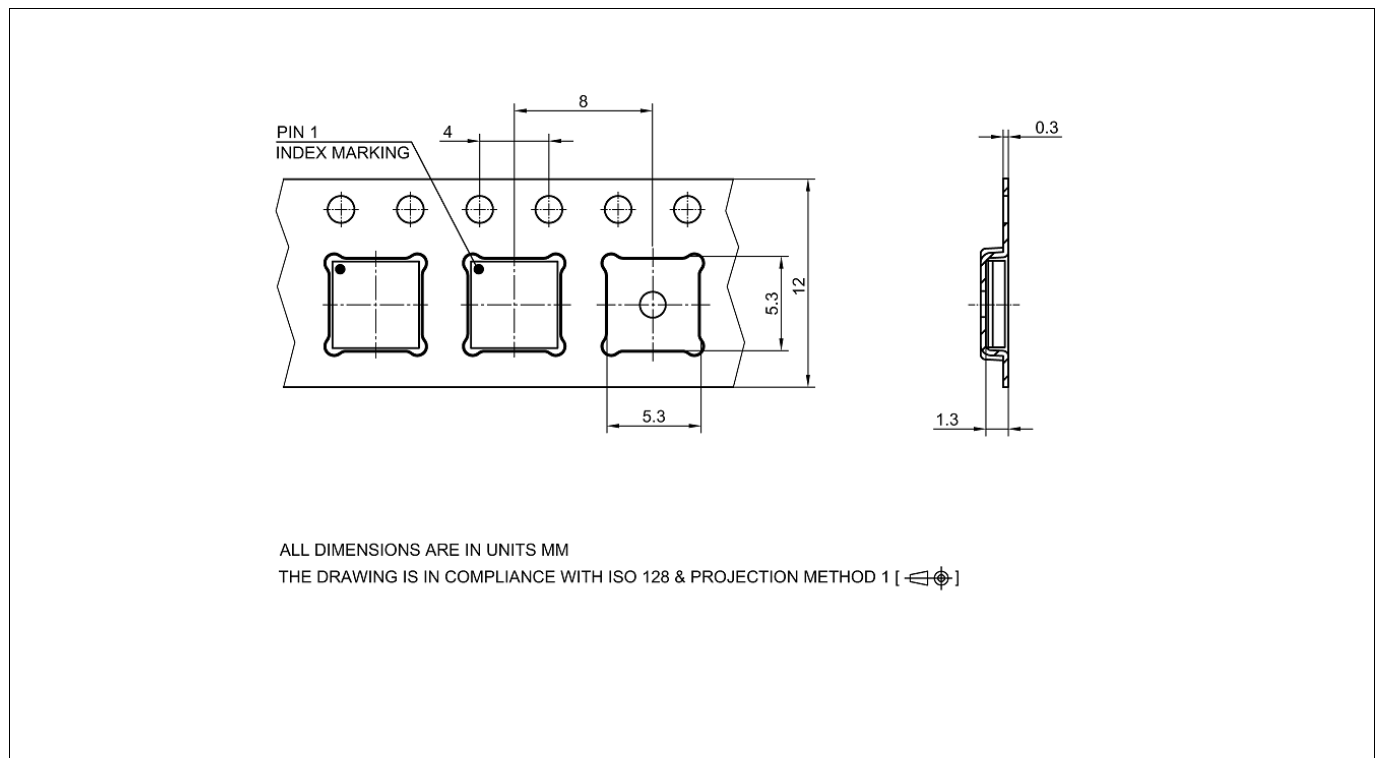

Figure 24 PG-TFLGA-13-1 packaging

GaN EiceDRIVER™ product family

GaN gate driver

Package outline dimensions

10.2 Package PG-DSO-16-11

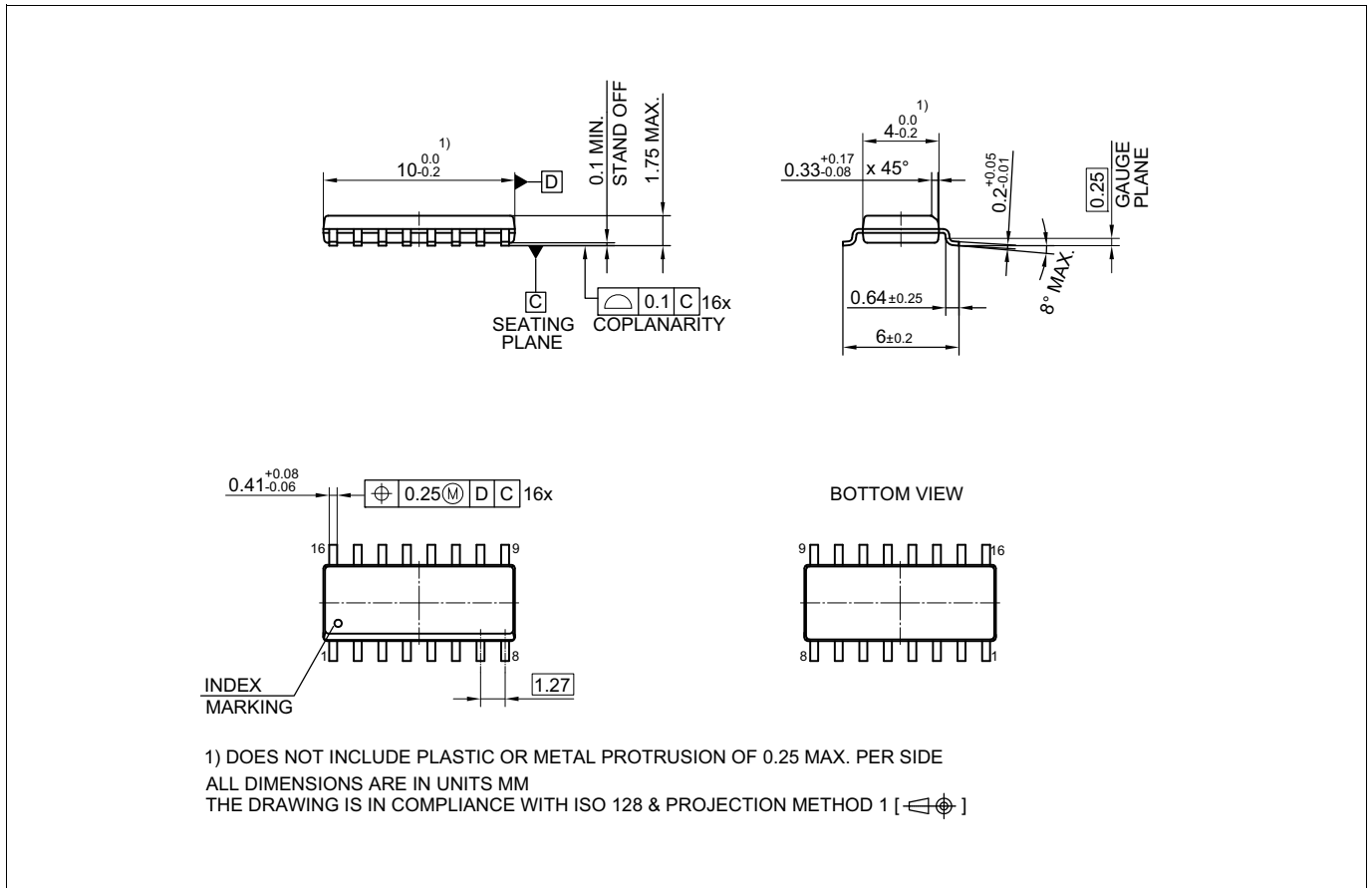

Figure 25 PG-DSO-16-11 outline

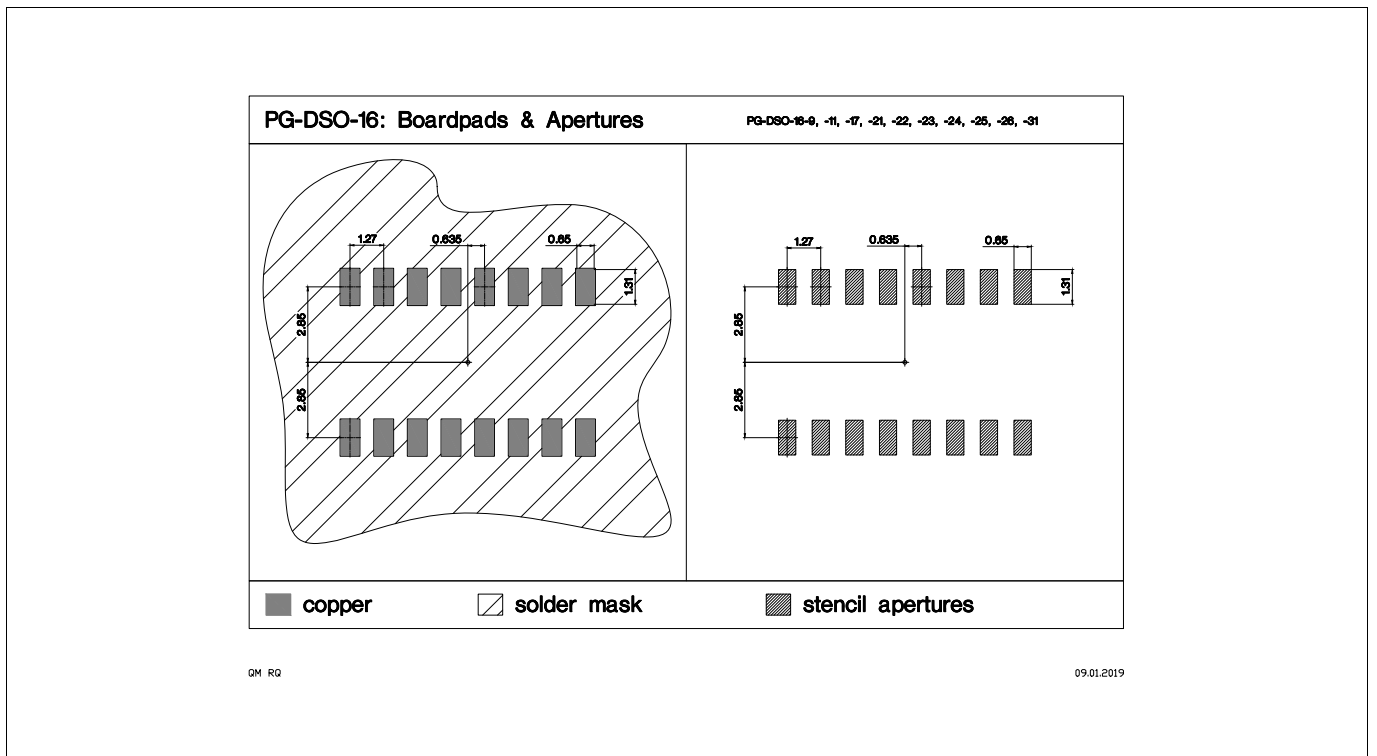

Figure 26 PG-DSO-16-11 footprint

GaN EiceDRIVER™ product family

GaN gate driver

Package outline dimensions

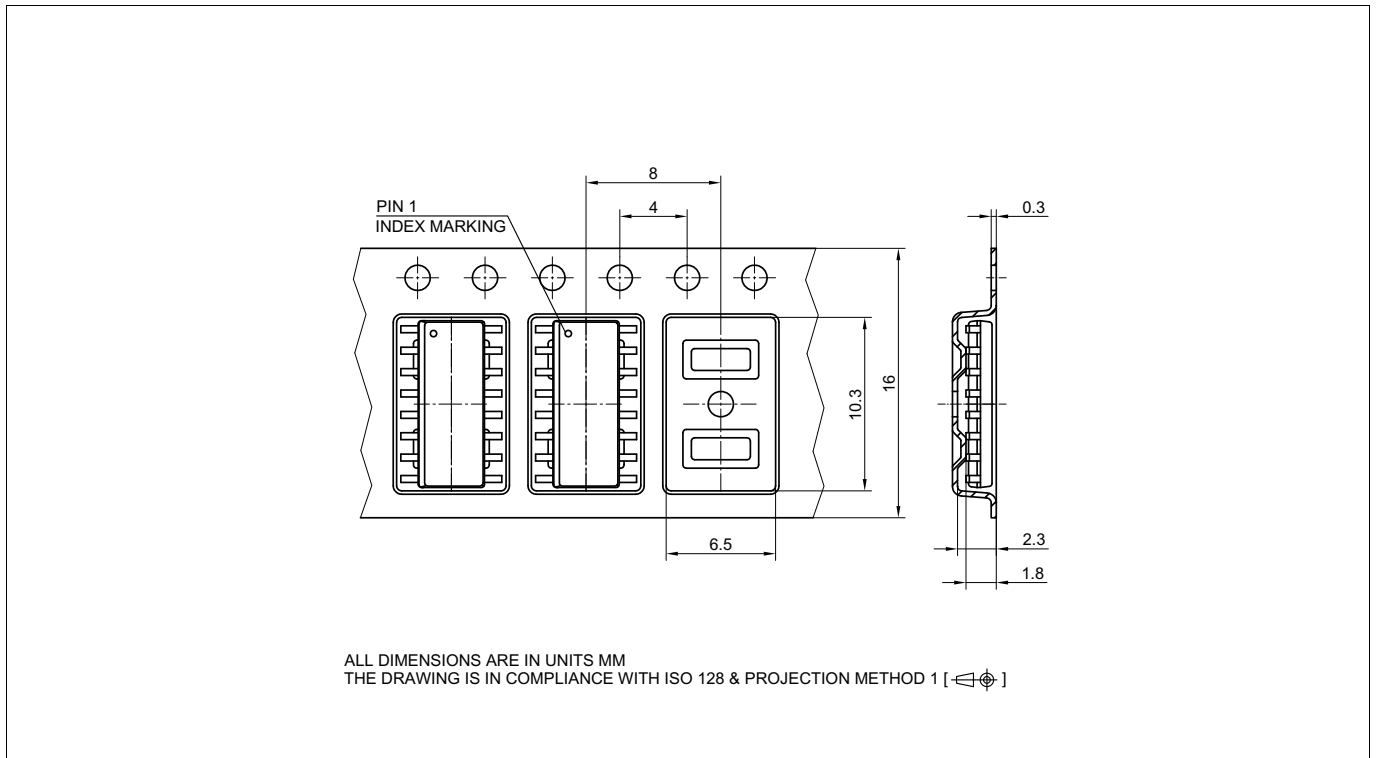

Figure 27 PG-DSO-16-11 packaging

10.3 Package PG-DSO-16-30

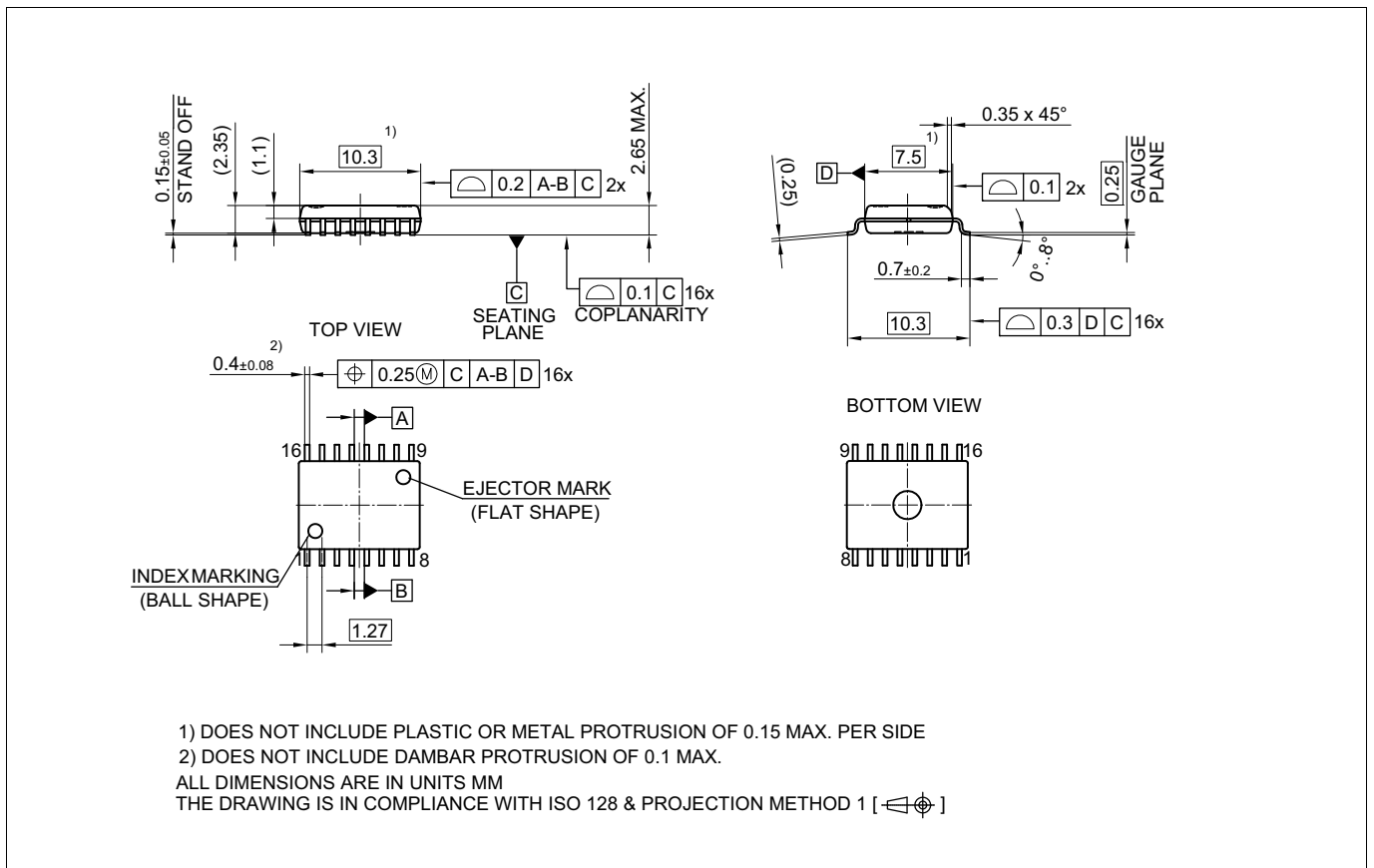

Figure 28 PG-DSO-16-30 outline

GaN EiceDRIVER™ product family

GaN gate driver

Package outline dimensions

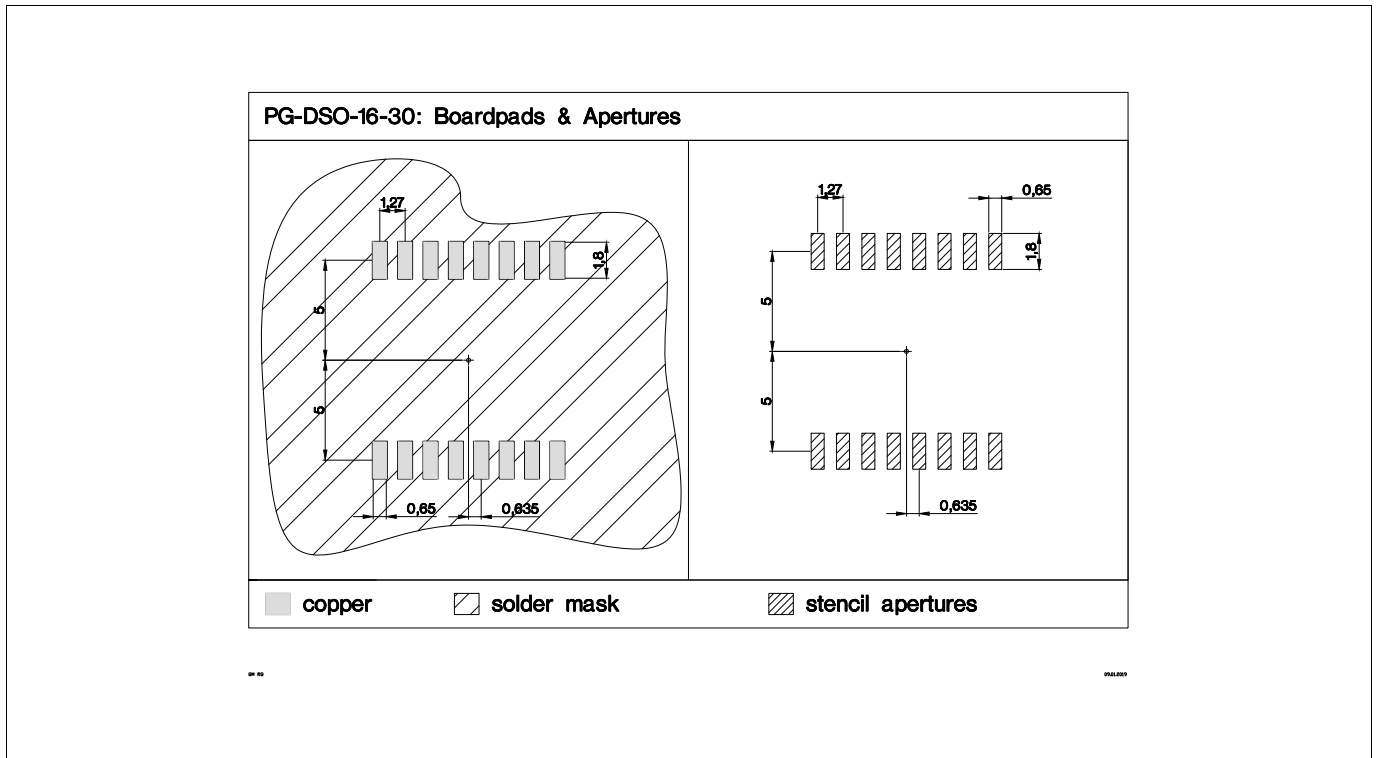

Figure 29 PG-DSO-16-30 footprint

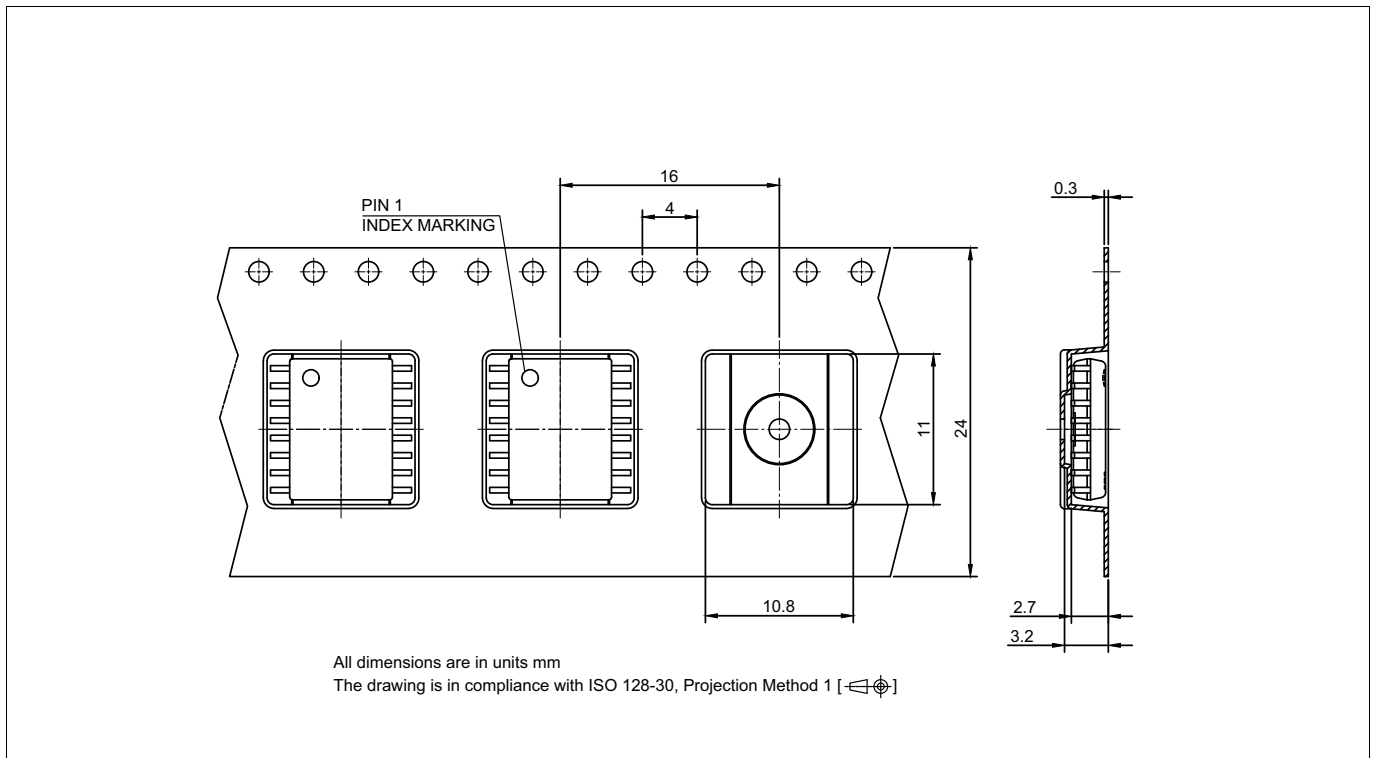

Figure 30 PG-DSO-16-30 packaging

GaN EiceDRIVER™ product family

GaN gate driver

Device numbers and markings

11 Device numbers and markings

Table 20 Device numbers and markings

Part number	Package	Orderable part number (OPN)	Device marking
1EDF5673K	PG-TFLGA-13-1	1EDF5673KXUMA1	1F5673B
1EDF5673F	PG-DSO-16-11	1EDF5673FXUMA1	1F5673B
1EDS5663H	PG-DSO-16-30	1EDS5663HXUMA1	1S5663B

GaN EiceDRIVER™ product family

GaN gate driver

Revision History

12 Revision History

Page or Item	Subjects (major changes since previous revision)
Rev. 2.3, 2020-10-22	
Isolation and safety approval	corrected certificate names
Table 1	safety certification: added footnote and corrected certificate name
Chapter 3.2	updated package description
Table 20	updated
Rev. 2.2, 2020-08-20	
Potential applications	updated
Table 1	certification received for VDE0884-10
Table 2	update equation for Pin 6
Table 2 and Chapter 3.7	t_1 change $\rightarrow t_1 = R_{t1} * 10.8$ pF
Chapter 3.7	updated description text
Table 5	C_{VDDI} max typo repaired
Table 5	Voltage at pins TNEG and SLDO \rightarrow Voltage at pins SLDO and removed symbol for V_{TNEG}
Table 8	t_1 parameter condition change $\rightarrow 18$ k Ω
Table 8	t_1 typ. value change $\rightarrow 194$
Figure 7	corrected typo
Figure 15	updated
Figure 17	updated
Figure 18	updated
Table 19	updated
Rev. 2.10, 2019-02-11	
Page 1	package diagrams update
Page 1	application diagram update
Figure 1 & Chapter 1	repaired typo in pin config diagram and chapter
Equation (2.1)	updated equation and relevant text
Figure 5	added optional resistor and diode
Equation (2.2)	updated to include R_{off}
Chapter 3.3.1	added description of I_{shunt}
Chapter 3.3.3	added chapter to describe power dissipation
Chapter 3.7	added description of possibility to reduce shortening effect
Chapter 4.3	updated footnote ⁽¹⁾ about V_{DDO} recommendation
Table 3	max. V_{DDI} : 3.7 V \rightarrow 4.0 V
Table 5	T_A max. value 85°C \rightarrow 125°C
Figure 17	updated components and dimensions
Chapter 8.1	added chapter on dimensioning guidelines

GaN EiceDRIVER™ product family

GaN gate driver

Revision History

Page or Item	Subjects (major changes since previous revision)
Figure 21	format change
Chapter 10	latest footprints, outlines and packaging
Rev. 2.00, 2018-11-07	
	Final datasheet created
Rev. 1.00, 2018-10-25	
	Initial version available

Trademarks

All referenced product or service names and trademarks are the property of their respective owners.

Edition 2020-10-22

Published by

Infineon Technologies AG

81726 Munich, Germany

© 2020 Infineon Technologies AG.

All Rights Reserved.

Do you have a question about any aspect of this document?

Email: erratum@infineon.com

Document reference

1EDF5673K, 1EDF5673F, 1EDS5663H

IMPORTANT NOTICE

The information given in this document shall in no event be regarded as a guarantee of conditions or characteristics ("Beschaffenhheitsgarantie").

With respect to any examples, hints or any typical values stated herein and/or any information regarding the application of the product, Infineon Technologies hereby disclaims any and all warranties and liabilities of any kind, including without limitation warranties of non-infringement of intellectual property rights of any third party.

In addition, any information given in this document is subject to customer's compliance with its obligations stated in this document and any applicable legal requirements, norms and standards concerning customer's products and any use of the product of Infineon Technologies in customer's applications.

The data contained in this document is exclusively intended for technically trained staff. It is the responsibility of customer's technical departments to evaluate the suitability of the product for the intended application and the completeness of the product information given in this document with respect to such application.

For further information on technology, delivery terms and conditions and prices, please contact the nearest Infineon Technologies Office (www.infineon.com).

WARNINGS

Due to technical requirements products may contain dangerous substances. For information on the types in question please contact your nearest Infineon Technologies office.

Except as otherwise explicitly approved by Infineon Technologies in a written document signed by authorized representatives of Infineon Technologies, Infineon Technologies' products may not be used in any applications where a failure of the product or any consequences of the use thereof can reasonably be expected to result in personal injury.

单击下面可查看定价，库存，交付和生命周期等信息

[>>Infineon\(英飞凌\)](#)