

32-Bit

Microcontroller

Application Kit TC2X5

Hardware: APPLICATION KIT TC2X5 V2.0

Hardware Manual

User's Manual

V 2.0 2013-05

Microcontrollers

Edition 2013-05

**Published by
Infineon Technologies AG
81726 Munich, Germany**

**© 2013 Infineon Technologies AG
All Rights Reserved.**

Legal Disclaimer

The information given in this document shall in no event be regarded as a guarantee of conditions or characteristics. With respect to any examples or hints given herein, any typical values stated herein and/or any information regarding the application of the device, Infineon Technologies hereby disclaims any and all warranties and liabilities of any kind, including without limitation, warranties of non-infringement of intellectual property rights of any third party.

Information

For further information on technology, delivery terms and conditions and prices, please contact the nearest Infineon Technologies Office (www.infineon.com).

Warnings

Due to technical requirements, components may contain dangerous substances. For information on the types in question, please contact the nearest Infineon Technologies Office.

Infineon Technologies components may be used in life-support devices or systems only with the express written approval of Infineon Technologies, if a failure of such components can reasonably be expected to cause the failure of that life-support device or system or to affect the safety or effectiveness of that device or system. Life support devices or systems are intended to be implanted in the human body or to support and/or maintain and sustain and/or protect human life. If they fail, it is reasonable to assume that the health of the user or other persons may be endangered.

32-Bit

Microcontroller

Application Kit TC2X5

Hardware: APPLICATION KIT TC2X5 V2.0

Hardware Manual

User's Manual

V 2.0 2013-05

Microcontrollers

Application Kit TC2X5 User's Manual

Revision History: V 2.0 2013-05

Previous Versions: 1.0

Page	Subjects (major changes since last revision)
all	adapt to hardware version V2.0
–	
–	

Trademarks

TriCore® is a trademark of Infineon Technologies AG.

We Listen to Your Comments

Any information within this document that you feel is wrong, unclear or missing at all?
Your feedback will help us to continuously improve the quality of this document.
Please send your proposal (including a reference to this document) to:

mcdocu.comments@infineon.com



Table of Contents

1	Introduction	1-1
2	Application Kit Features	2-1
2.1	Summary of Features	2-1
2.2	Block Diagram	2-3
2.3	Placement	2-4
3	Application Kit Information	3-1
3.1	Power Supply	3-1
3.1.1	Power via supply connector (X101)	3-1
3.1.2	Shutdown the board	3-1
3.2	Real Time Clock	3-1
3.3	XGA Display	3-2
3.3.1	Write a display register	3-2
3.3.2	Read a display register	3-2
3.3.3	Touch controller	3-3
3.4	Micro SD card	3-3
3.5	LEDs	3-3
3.6	Clock	3-4
3.7	USB Connector	3-4
3.7.1	Serial Connection to PC	3-4
3.7.2	miniWiggler JDS	3-4
3.8	Beeper	3-5
3.9	MultiCAN	3-5
3.10	LIN	3-5
3.11	Ethernet	3-5
3.12	Other peripherals	3-5
3.13	Toggle LED's	3-5
3.14	Debug System	3-5
3.14.1	OCDS1	3-5
4	Signal Description	4-1
5	Connector Pin Assignment	5-1
5.1	IO Connectors	5-1
5.2	Power connector pinout	5-2
5.3	USB connector pinout	5-2
5.4	CAN connector pinout	5-2
5.5	LIN connector pinout	5-3
5.6	OCDS connector pinout	5-3
5.7	Ethernet Connector	5-4
5.8	DAP connector pinout	5-4

6	Schematic and Layout	6-1
6.1	Schematic	6-1
6.2	Layout	6-6
6.3	Layout with Dimensioning	6-8

List of Figures

Figure 2-1	Application Kit TC2X5 Block Schematic	2-3
Figure 2-2	Application Kit TC2X5 V2.0 Top Placement	2-4
Figure 2-3	Application Kit TC2X5 V2.0 Bottom Placement	2-5
Figure 5-1	IO Connectors - Pinout	5-1
Figure 5-2	Power connector pinout	5-2
Figure 5-3	USB connector Pinout	5-2
Figure 5-4	CAN connector pinout (IDC10)	5-2
Figure 5-5	LIN connector pinout (IDC10)	5-3
Figure 5-6	OCDS connector pinout (IDC16)	5-3
Figure 5-7	Ethernet connector pinout (RJ45)	5-4
Figure 5-8	DAP connector pinout (FTSH10)	5-4
Figure 6-1	Schematic - Project	6-2
Figure 6-2	Schematic - CPU and Power Supply	6-3
Figure 6-3	Schematic - Peripherals	6-4
Figure 6-4	Schematic - miniWiggler JDS and OCDS1	6-5
Figure 6-5	Component Plot Top Layer	6-6
Figure 6-6	Component Plot Bottom Layer	6-7
Figure 6-7	Dimensioning (mm)	6-8
Figure 6-8	Dimensioning (mil)	6-9

List of Tables

Table 4-1	Power Signals	4-1
Table 4-2	Reset Signals	4-1
Table 4-3	Interrupt Signals	4-1
Table 4-4	Clock Signals	4-2
Table 4-5	Debug Signals	4-2
Table 4-6	Peripheral Signals	4-2

1 Introduction

We congratulate you on your purchase of the TriCore Evaluation Board. This kit is a versatile tool, providing quick access to the capabilities of TriCore's powerful architecture.

Applications can be developed easily. The Application Kit is equipped with a variety of peripherals for connection to the environment. There is also an interface for the On Chip Debugging Features.

The Application Kit allows easily the development of TriCore applications with the corresponding tools.

Subsequently, the applications can be downloaded and can be tested with the powerful debugger software.

This Application Kit Hardware Manual familiarizes you with the TriCore Evaluation Board and guides you through the initial configuration of the Application Kit.

For detailed technical information about the TC2X5 (e.g. TC275, TC265, TC2D5) please refer to the User Manual of the device.



2 Application Kit Features

2.1 Summary of Features

- Infineon's TC2X5 (e.g. TC275, TC265) Controller in LQFP-176 Package
- LCD XGA Display 320x240
- SD card slot (mini SD)
- High Speed CAN Transceivers
- USB to UART bridge
- Ethernet Gigabit PHY
- LIN Transceiver
- Crystal 20MHz (default) or External Clock
- USB miniWiggler JDS for easy debugging
- 4Low Power Status LEDs
- RTC with alarm
- Acoustic beeper
- 100mm x 100mm

Connectors

The Application Kit TC2X5 Offers a wide variety of connectors:

- Standard power connector
- Micro USB connector for ASC Interface (ASC0) and miniWiggler
- RJ45 connector for Ethernet
- 16-pin header for JTAG interface (OCDS)
- 10-pin header for DAP (optional)
- 10pin (2x5) Header for LIN Transceiver (LIN)
- 10pin (2x5) Header for CAN High Speed Transceiver (CAN0)
- two 40-pin connectors with I/O signals
- mini SD card slot

Components

- Infineon's Next generation micro controller supply TLE 7368-3E
- LED to validate power supply (5Volt)
- LED indicating RESET (ESR0) active state
- LED indicating activ miniWiggler JDS
- LED switched via DAS software
- Infineon's High Speed CAN-Transceiver TLE 6250 G
- Infineon's LIN-Transceiver TLE 7259-2GE
- I2C™ Real-Time Clock/Calendar with SRAM MCP7940M
- USB to UART bridge FT2232HL (FTDI)
- Single Port Gigabit Ethernet PHY PEF7071 (LANTIQ)

Application Kit Features

- Touch screen controller ADS7843
- 4 general purpose LEDs
- Reset switch
- Start switch
- Xilinx CPLD XC9572XL

2.2 Block Diagram

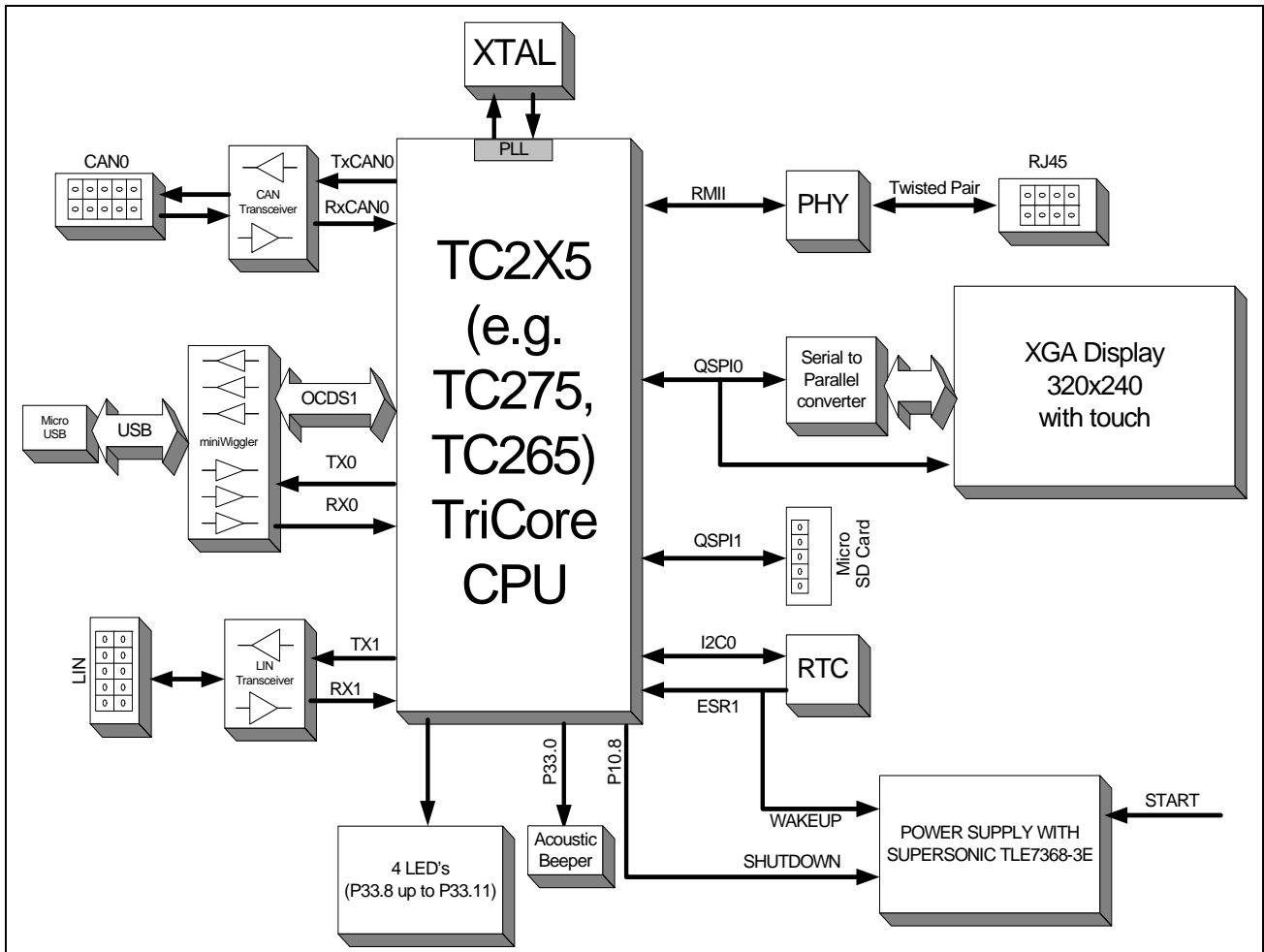

Figure 2-1 Application Kit TC2X5 Block Schematic

2.3 Placement

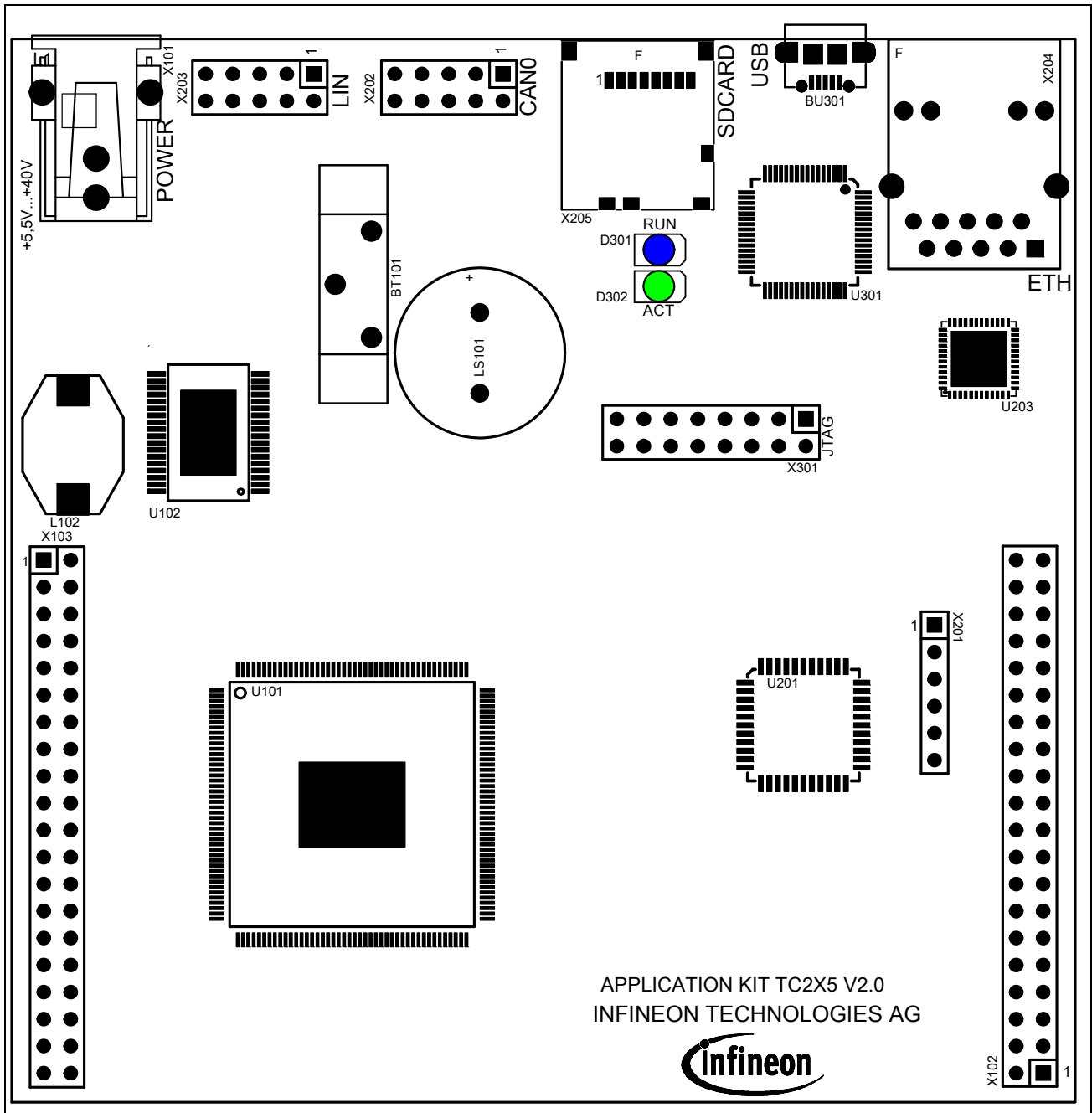

Figure 2-2 Application Kit TC2X5 V2.0 Top Placement

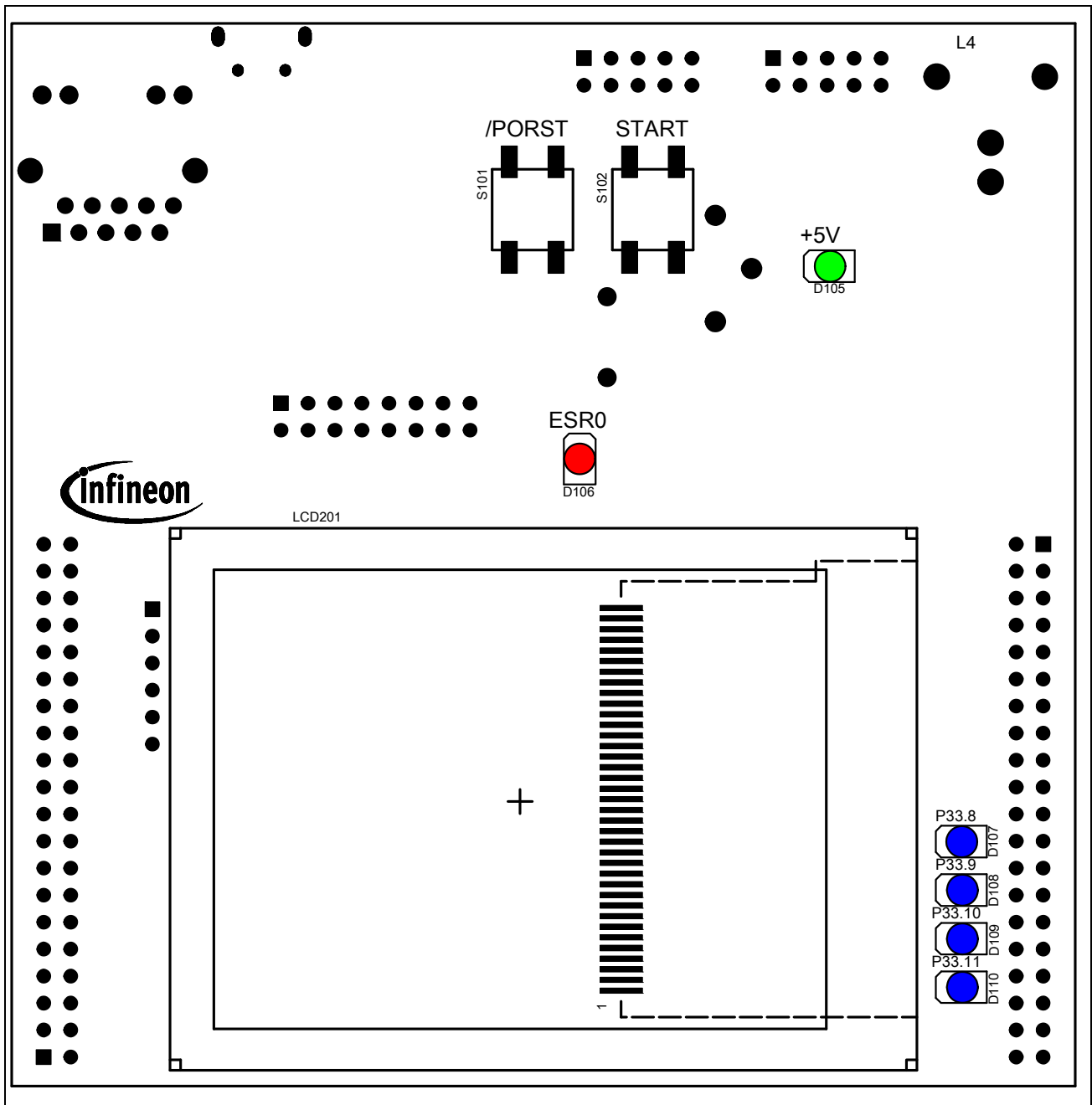

Figure 2-3 Application Kit TC2X5 V2.0 Bottom Placement



3 Application Kit Information

3.1 Power Supply

The microcontroller needs 3 different supply voltages. This voltages are generated internally via Infineons Next generation microcontroller supply TLE 7368-3E (+5V; +3,3V) and via the microcontroller itself (+1,3V).

Applying a stable supply voltage causes the power on reset after a short period. The LED' (+5V) indicate the status of the 5V voltage.

A manual power on reset is executed by pressing the reset button.

NOTE: TO POWER UP THE BOARD YOU MUST PRESS SHORT THE START BUTTON.

3.1.1 Power via supply connector (X101)

The Board has to be connected to a +5,5V to +40V DC power supply.

The power consumption is not specified yet but a supply with 6V and 600mA should be sufficient. The pinout for the supply connector is shown in [Figure 5-2](#). There can be used any standard power pack with a connector where the positive line is surrounded by the ground line.

3.1.2 Shutdown the board

The board can be switched off by disconnecting the power plug or by software via pin P10.8. A low level on pin P10,8 will switch off the power regulator except the standby supply of 2,6V. In this case all only the RTC is working and can wake up the board by an alarm. In this case you shouldn't remove the power connector. Make sure that there is not active alarm from the RTC when you need to switch off the board. In case of an active alarm the board is not switched off.

3.2 Real Time Clock

The board is equipped with a RTC MCP7940M from Microchip. The device is powered from the standby voltage of the TLE7368 and is also powered when the TLE7368 is switched off. For backup when the TLE7368 is not powered then there is a small battery to hold the value inside the RTC. When the battery is not installed (e.g. first time use) you could insert the battery in the holder to keep the time. The RTC is connected to the microcontroller via I2C bus and can trigger an ESR1 interrupt (activ high) with the alarms. Also an alarm from the RTC will wake-up (switch on) the board if the board is powered and not started (shutdown). For more information about the RTC please see the datasheet of MCP7940M.

3.3 XGA Display

The board has an XGA Display with a resolution of 320x240. The display has an ILI932x display controller. Please see the datasheet of the display controller for the register of the controller. The display is connected to the the microcontroller via an SPI to Parallel converter (U201).

The SPI to Parallel converter is based on a statemachine. This statemachine is clocked with the clock of SPI, here SCLK0 (P20.11). Each rising edge of P20.11 will change the state of statemachine. When SLSO08 (P20.6) is not low then the statemachine will go always in the idle state.

3.3.1 Write a display register

A single write to any register can be done by a 32 bit transfer of SPI. Make sure that the SLSO08 is low during this 32 bit. Bit 31 must be transferred first.

Bit 31 must be 0, this will be indicate a write access.

Bit 30 must be 0, this will be indicate a single access.

Bit 29...Bit 22 is the 8 bit register number which will be written

Bit 21...Bit 6 is the 16bit value which will be written

Bit 5...Bit 0 are dummy bits which are used to execute the write.

To speedup the writing (e.g. write to ram of display controller) it is possible to make a endless transfer. This is done by this:

first 10 bit transfer

Bit 9 must be 0, this will be indicate a write access.

Bit 8 must be 1, this will be indicate an endless transfer.

Bit 7...Bit 0 is the 8 bit register number which will be written

Now you need to transfer only 16bit values for the registers. With the first 16 bit value there is no action on the display. With the second value transfer is a write to the register started. This means after the last value you must make a dummy transfer to write the last value.

The endless mode can only be leave by a rising edge of SCLK0 with SLSO08 set to high. This can be done by a dummy transfer to any other chip select or by a transfer from the touch controller.

3.3.2 Read a display register

A single read from any register can be done by a 32 bit transfer of SPI. Make sure that the SLSO08 is low during the complete transfer.

first transfer has 16 bit:

Bit 15 must be 1, this will be indicate a read access.

Bit 14 must be 0, this will be indicate a single access.

Bit 13...Bit 7 is the 8 bit register number which will be read

Bit 5...Bit 0 are dummy bits to setup the register number.

second transfer must have 26 bits:

Bit 25...Bit 16 are dummy bits which are needed to readout the register value

Bit 15...Bit 0 are dummy bits to transfer the readed value.

To speedup the reading (e.g. reading from ram of display controller) it is possible to make a endless transfer. This is done by this:

first 16 bit transfer:

first transfer has 16 bit:

Bit 15 must be 1, this will be indicate a read access.

Bit 14 must be 1, this will be indicate an endless access.

Bit 13...Bit 7 is the 8 bit register number which will be read

Bit 5...Bit 0 are dummy bits to setup the register number.

second 10 bit transfer:

Bit 9...Bit 0 are dummy bits which are needed to readout the register value

Now you need to transfer only 16bit values for the registers. With the each 16 bit transfer you get a value. With the last transfer you have dummy read which you don't get the result.

The endless mode can only be leave by a rising edge of SCLK0 with SLISO08 set to high. This can be done by a dummy transfer to any other chip select or by a transfer from the touch controller.

3.3.3 Touch controller

The touch of display is connected to an Touch controller ADS7843. This controller is connected via the QSPI0 and SLISO09 to the microcontroller. For motre information about the delivered values from the touch controller please see the datasheet of ADS7348.

3.4 Micro SD card

The board has a slot to use the board with an micro SD card. The card will be used in SPI mode only. The SD is connected to QSPI1 with chip select 10 of QSPI1.

Please see additional literature jow to use a SD card in SPI mode.

3.5 LEDs

There are 8 LEDs on board:

Application Kit Information

- D109 up to D112 (blue) -> toggle LEDs connected to P33.8 ... P33.11
- D108 ESR0 (red) -> RESET LED indicate the reset state of the board
- D107 +5V (green) -> +5V power supply indication
- D302 ACT (green) -> on board miniWiggler JDS is ACTIV
- D301 RUN (blue) -> Debug RUN mode (switched by DAS Server)

3.6 Clock

On the board is a fixed crystal with 20MHz assembled. You can change this by replacing Y101 (soldered).

3.7 USB Connector

The USB connector is used for connection to a PC. Via the USB it is possible to power the board, using the ASCLIN0 as serial connection via USB and Debugging via DAS. For the pinout of USB socket see [Figure 5-3](#).

NOTE: Before connecting the board to the PC, make sure that the actual DAS software is installed on the PC. For actual DAS software please contact your local FAE.

The software can also be found on the

[DAS website](#)

3.7.1 Serial Connection to PC

After the first connection of USB to a PC the needed driver will be installed automatically. During this there will be created a new COM port on PC. This COM port can be used to communicate with the board via ASC0 of the device (e.g. bootstrap loader).

3.7.2 miniWiggler JDS

The miniWiggler JDS is a low cost debug tool which allows you access to the JTAG of the device. Make sure that you have the latest DAS release. Debugging is possible via the DAS Server 'UDAS'. Please contact your preferred debug vendor for support of DAS.

If you have connected the board to the PC and there runs the DAS server, then a working connection is visible via the green ACTIV LED.

The status RUN LED is switched on/off through the DAS Server, depending on the used debugger (client).

IMPORTANT: Make sure that there is no or a tristated connection on X301 (OCDS1) if the ACTIV LED is on.

3.8 Beeper

The board has an electro-acoustic transducer which can be used for an acoustic output. The transducer is connected to pin P33.0 and needs a 2048Hz frequency.

3.9 MultiCAN

On the board is one CAN transceiver connected to the MultiCAN on TC2X5 node 0. The transceiver is connected to an IDC10 plug. For the pinout of IDC10 plug see [Figure 5-4](#). You can use a IDC female connector with crimpconnector, flat cable and SUB-D 9 plug with crimpconnector to have a 1:1 adapter to SUB-D 9.

3.10 LIN

On the board is one LIN transceiver connected to the ASCLIN1 on TC2X5. The transceiver are connected to one IDC10 plug. For the pinout of IDC10 plug see [Figure 5-5](#). You can use a IDC female connector with crimpconnector, flat cable and SUB-D 9 plug with crimpconnector to have a 1:1 adapter to SUB-D 9.

3.11 Ethernet

The Application Kit provide a RJ45 connector (X204) for twisted pair ethernet connections. The board use a Lantiq Gigabit PHY PEF7071 as physical interface device. For more information about the ethernet modul see TC2X5 User's Manual, about the PHY see the PEF7071 datasheet. For the pinout of RJ45 see [Figure 5-7](#).

3.12 Other peripherals

For all other peripherals there are no special plugs on the board. Many of the peripheral signals are available on the two standard connectors X102 and X103. See "[Connector Pin Assignment](#)" on [Page 5-1](#).

3.13 Toggle LED's

Port 33 pin 8 up to pin 11 are connected to single LED's (D109... D112) and can be controlled by Software. This status LED's are low active.

3.14 Debug System

3.14.1 OCDS1

The OCDS1 signals are connected to the IDC16 plug (X301). They work with the port supply of +3.3V. For pinout of the connector see [Figure 5-6](#). You can connect any debugger to this connector.

Application Kit Information

If you connect a debug hardware make sure that the miniWiggler JDS (see “[miniWiggler JDS](#)” on [Page 3-4](#)) is not active (ACTIV LED is off).

If the ACTIV LED is on, then stop the active DAS Server 'UDAS' and/or remove the USB connection to the PC.

4 Signal Description

For more information about the signals please see the user manuals for TC2X5 and/or the schematics of the board.

Table 4-1 Power Signals

Short Name	Description
VCC_IN	Supply Input (5,5V...50V(40V))
VIN	Input voltage of power supply device
GND	Ground
VEXT	External Supply Voltage (5V or 3,3V)
VDD	Core Supply Voltage (1,3V)
VDDP3	Port Supply Voltage (3,3V)
VFLEX	Flexport Supply Voltage (3,3V)
VDDFL3	Flash Supply Voltage (3,3V)
VDDSB	Emulation Stand-by SRAM Supply Voltage (1,3V)
VSS	Oscillator Ground
VSSM	ADC Analog Part Ground
VDDM	ADC Analog Part Supply Voltage (5V or 3,3V)
VAGND1	ADC Reference Ground 1
VAGND2	ADC Reference Ground 2
VAREF1	ADC Reference Voltage 1 (VDDM)
VAREF2	ADC Reference Voltage 2 (VDDM)
VDD_FT	Supply Voltage FT2232HL device (3,3V)

Table 4-2 Reset Signals

Short Name	Description
/PORST	Power On Reset
/PORST_DBG	Power On Reset from debug connectors
/ESR0	External Service Request 0 (Hardware Reset)
/ESR1	External Service Request 1 (Non Maskable Interrupt)

Table 4-3 Interrupt Signals

Short Name	Description
REQ1 / P15.8	External Trigger Input 1

Table 4-3 Interrupt Signals

REQ3 / P10.3	External Trigger Input 3
REQ4 / P10.7	External Trigger Input 4 (Touch activiv)
REQ5 / P10.8	External Trigger Input 5
REQ8 / P33.7	External Trigger Input 8
REQ10 / P14.3	External Trigger Input 10 (MD Interrupt)

Table 4-4 Clock Signals

Short Name	Description
XTAL1	Crystal Oscillator Input
XTAL2	Crystal Oscillator Output

Table 4-5 Debug Signals

Short Name	Description
/TRST	Test Reset
TCK / DAP0	Test Clock / Device Access Pin 0
TMS / DAP1	Test Mode Select / Device Access Pin 1
TDI / P21.6	Test Data Input
TDO / P21.7	Test Data Output
/TESTMODE / P20.2	Test Mode Select Input

Table 4-6 Peripheral Signals

Short Name	Description
P14.1	Receive Data ASC0
P14.0	Transmit Data ASC0
P15.1	Receive Data ASC1
P15.0	Transmit Data ASC1
SCLK0 / P20.11	Clock Line SSC0
MRST0A / P20.12	Master Receive / Slave Transmit SSC0
MTRSR0 / P20.14	Master Transmit / Slave Receive SSC0
SLSO08 / P20.6	Slave Select Output 8 (SSC0)
SLSO09 / P20.3	Slave Select Output 9 (SSC0)
SCLK1 / P10.2	Clock Line SSC1
MRST1A / P10.1	Master Receive / Slave Transmit SSC1

Table 4-6 Peripheral Signals

MTSR1 / P10.3	Master Transmit / Slave Receive SSC1
SLSO110 / P10.0	Slave Select Output 10 (SSC1)
P20.8	CAN Transmitter Output 0
P20.7	CAN Receiver Input 0
P21.0	Ethernet MDC
P21.1	Ethernet MDIO (TC275A only)
P21.3	Ethernet MDIO (not for TC275A)
P11.2	Ethernet TXD1
P11.3	Ethernet TXD0
P11.6	Ethernet TXEN
P11.12	Ethernet REFCLK
P11.9	Ethernet RXD1
P11.10	Ethernet RXD0
P11.11	Ethernet CRSDIV
P11.12	Ethernet REFCLK
AN[0...47]	Analog Inputs
P13.1	I2C Clock
P13.2	I2C Data
P10.8	Shutdown the power supply
P33,0	Beeper output (2048Hz)
P33[8...11]	On board LED's

5 Connector Pin Assignment

The Application Kit will be shipped with two 40 pin male (plug) connectors on top layer with a standard grid of 2,54mm.

5.1 IO Connectors

		X102						X103			
VCC_IN		1	2	VEXT		VCC_IN		1	2	VEXT	
GND		3	4	GND		GND		3	4	GND	
AN21		5	6	AN20		P14.10		5	6	P14.9	
AN17		7	8	AN16		P14,8		7	8	P14.7	
AN3		9	10	AN2		P14,6		9	10	P10.6	
AN1		11	12	AN0		P10.5		11	12	P10.4	
P33.5		13	14	P32.2		P02.0		13	14	P02.1	
P32.3		15	16	P32.4		P02.2		15	16	P02.3	
P33.13		17	18	P33.12		P02.4		17	18	P02.5	
P33.7		19	20	P33.6		P02.6		19	20	P02.7	
P23.0		21	22	P23.1		P02.8		21	22	P00.0	
P23.2		23	24	P23.3		P00.1		23	24	P00.2	
P23.4		25	26	P23.5		P00.3		25	26	P00.4	
P22.0		27	28	P22.1		P00.5		27	28	P00.6	
P22.2		29	30	P22.3		P00.7		29	30	P00.8	
P15.2		31	32	P15.3		P00.9		31	32	P00.10	
P15.4		33	34	P15.5		P00.11		33	34	P00.12	
P15.6		35	36	P15.7		AN45		35	36	AN44	
P20,9		37	38	P20.10		AN33		37	38	AN32	
P14.2		39	40	P14.5		AN25		39	40	AN24	

Figure 5-1 IO Connectors - Pinout

5.2 Power connector pinout

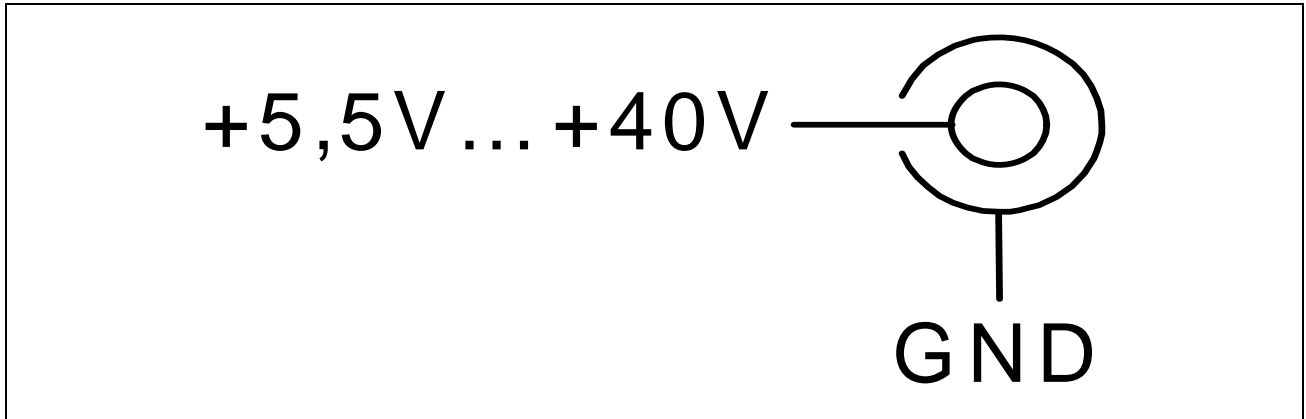

Figure 5-2 Power connector pinout

5.3 USB connector pinout

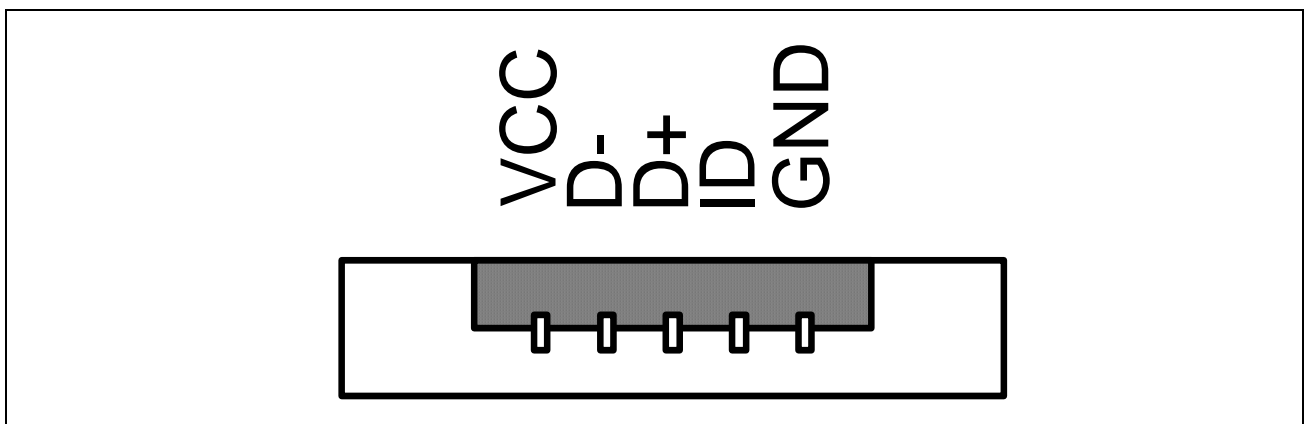

Figure 5-3 USB connector Pinout

5.4 CAN connector pinout

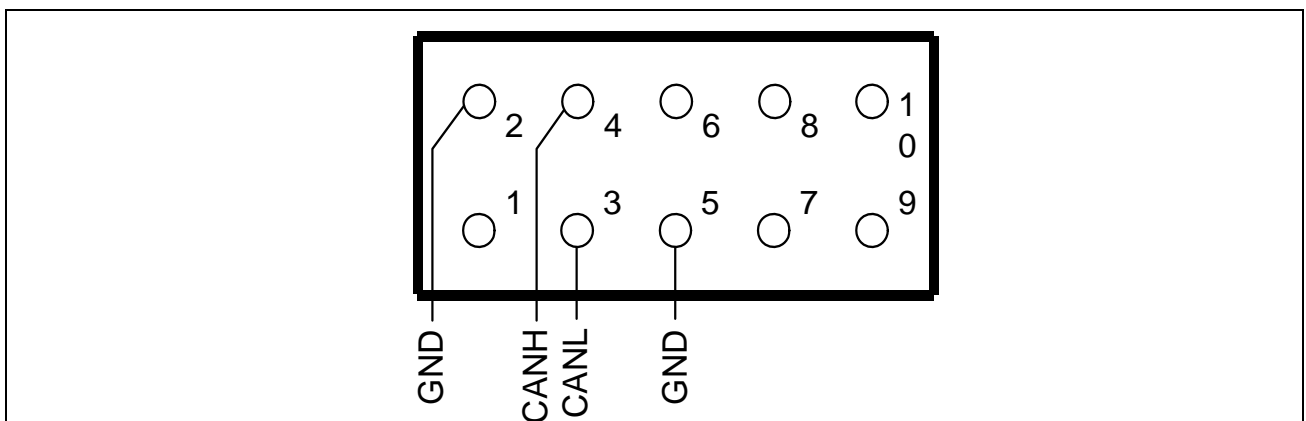

Figure 5-4 CAN connector pinout (IDC10)

5.5 LIN connector pinout

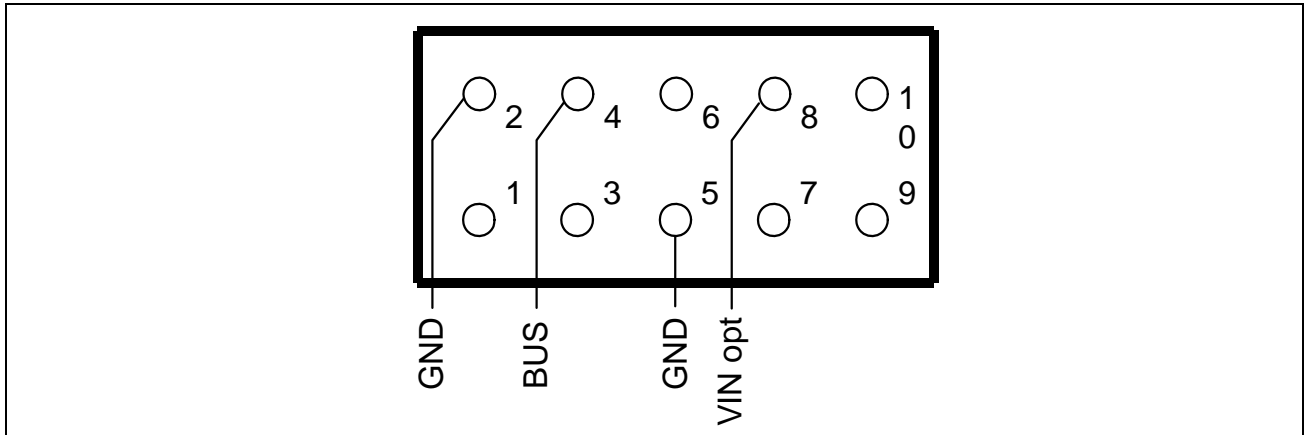

Figure 5-5 LIN connector pinout (IDC10)

5.6 OCDS connector pinout

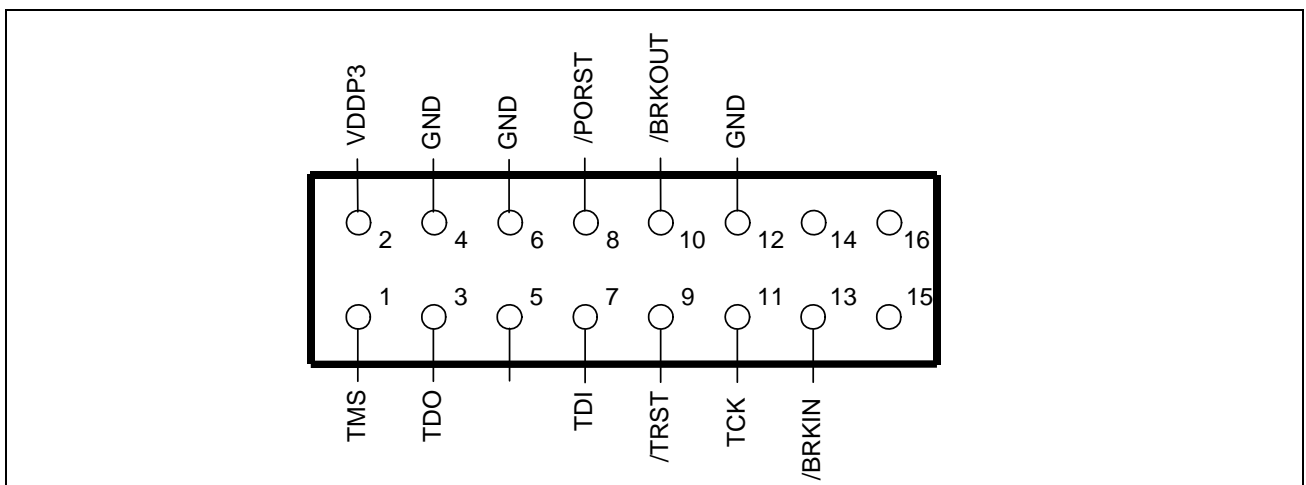

Figure 5-6 OCDS connector pinout (IDC16)

5.7 Ethernet Connector

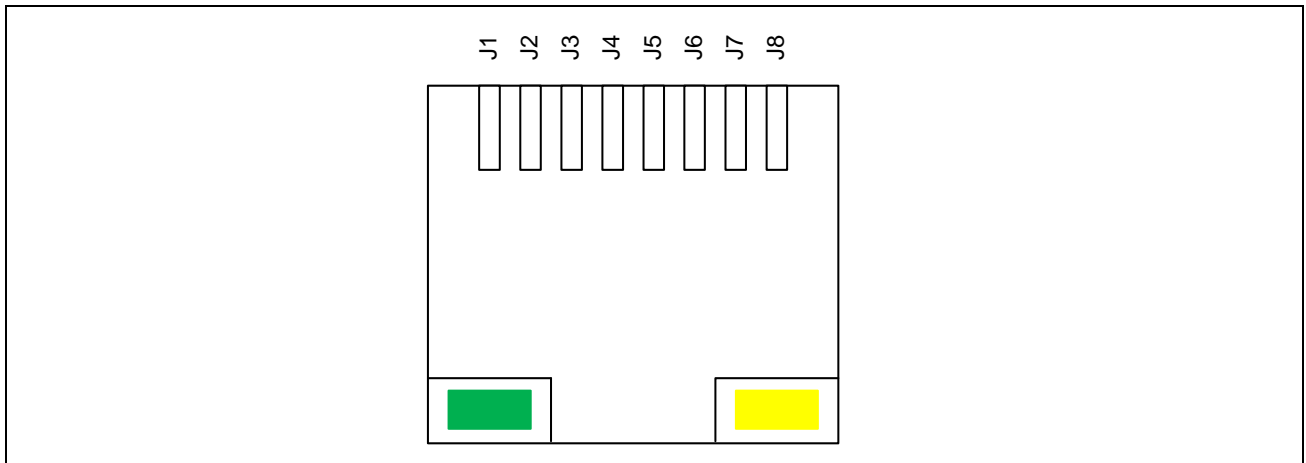

Figure 5-7 Ethernet connector pinout (RJ45)

5.8 DAP connector pinout

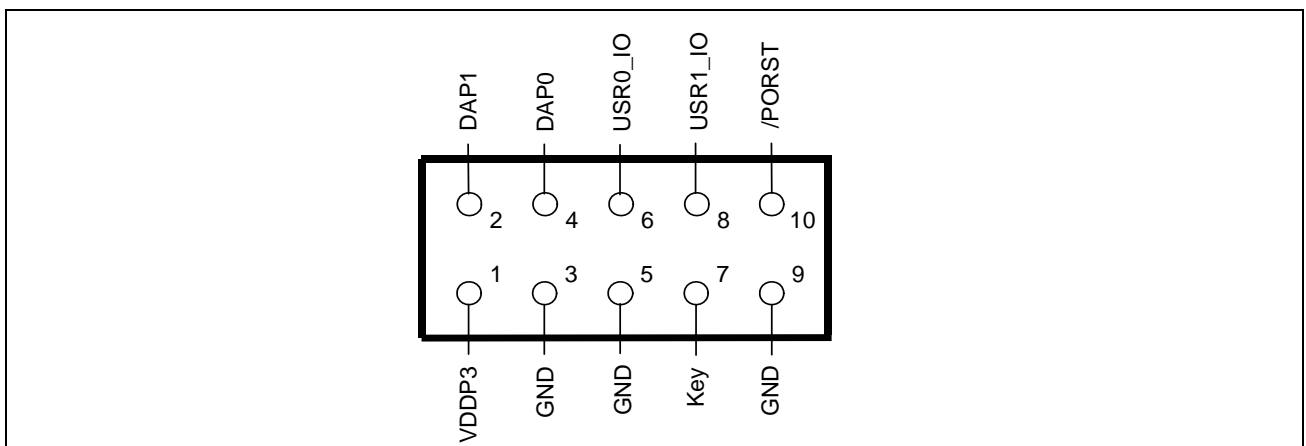

Figure 5-8 DAP connector pinout (FTSH10)

6 Schematic and Layout

6.1 Schematic

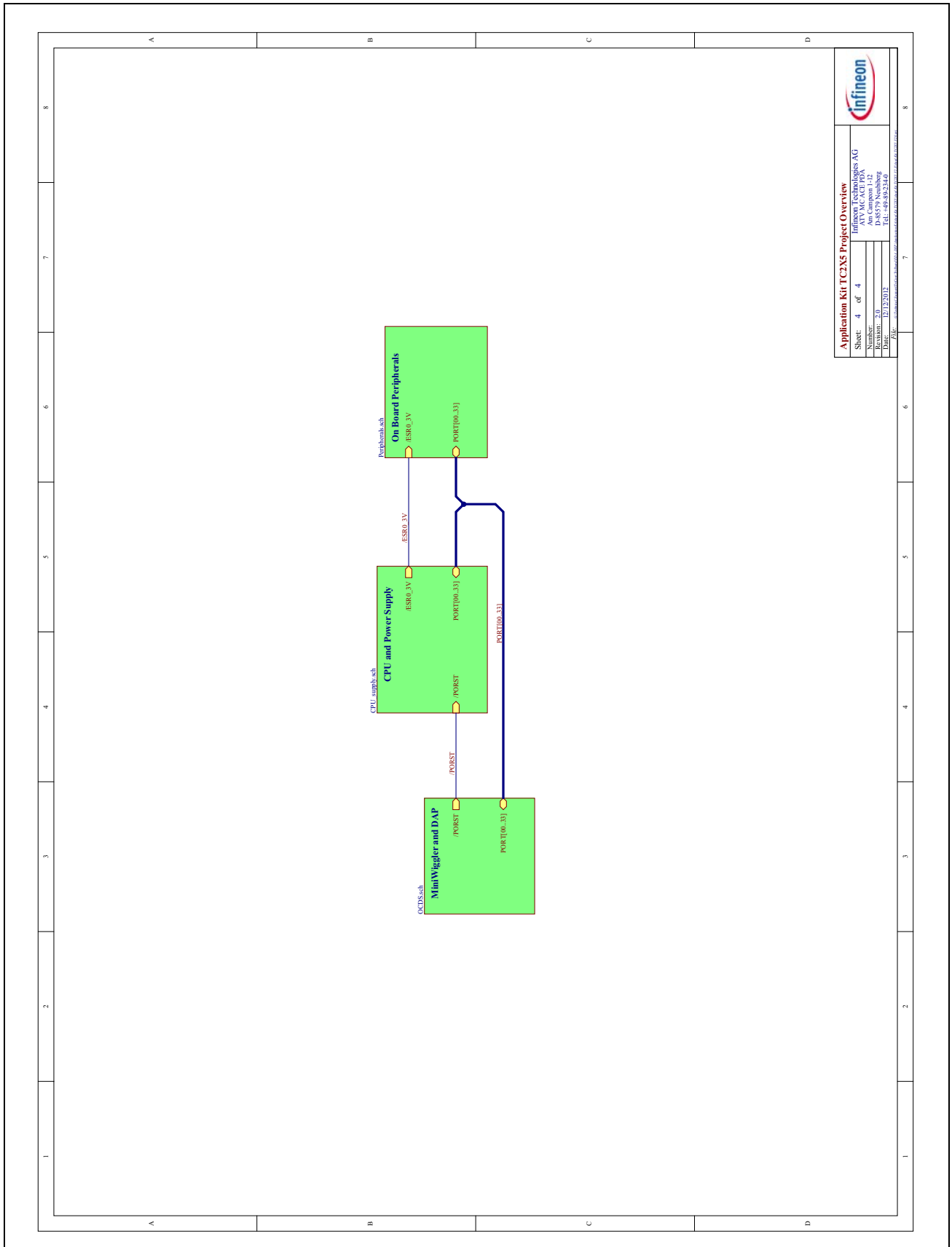

Figure 6-1 Schematic - Project

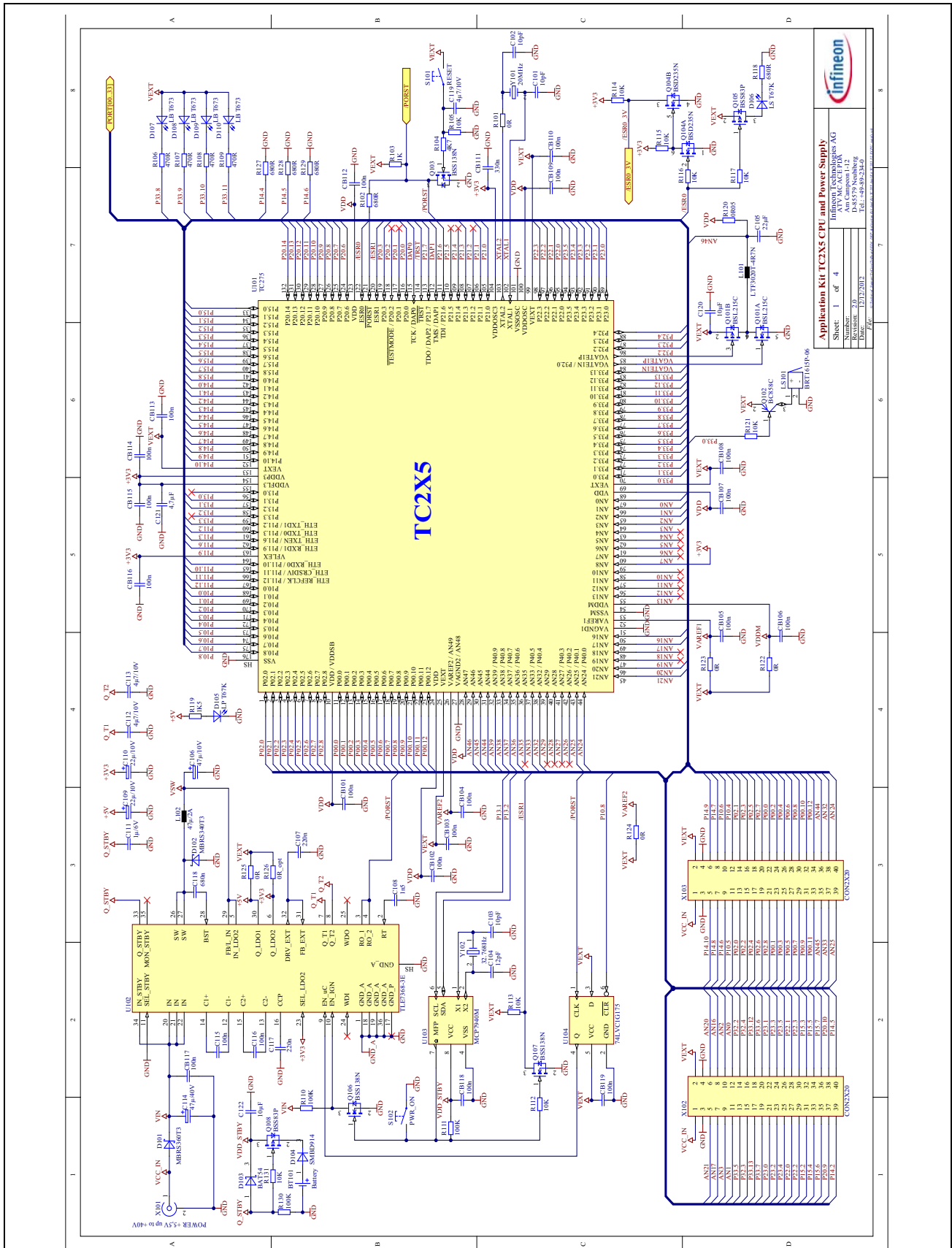

Figure 6-2 Schematic - CPU and Power Supply

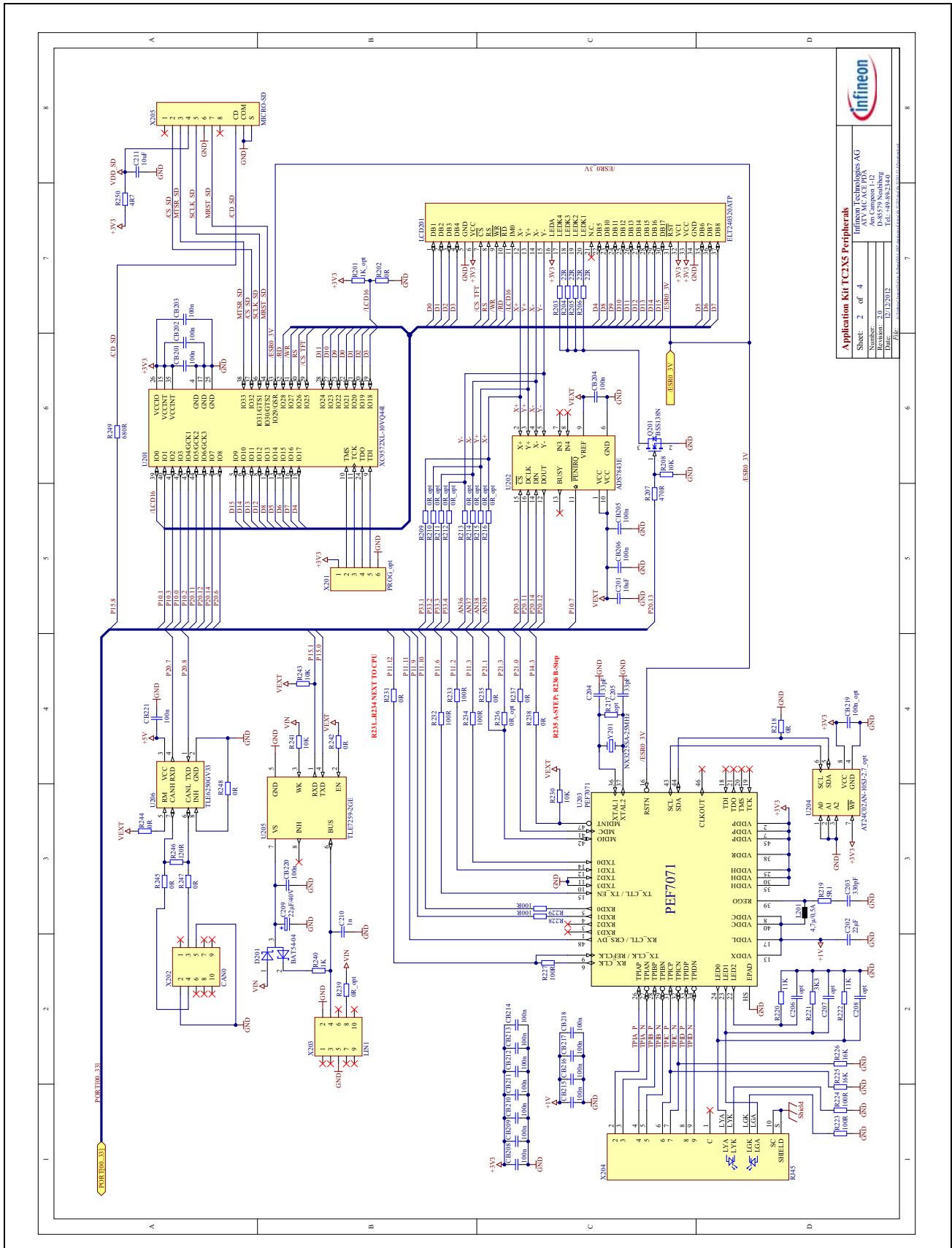

Figure 6-3 Schematic - Peripherals

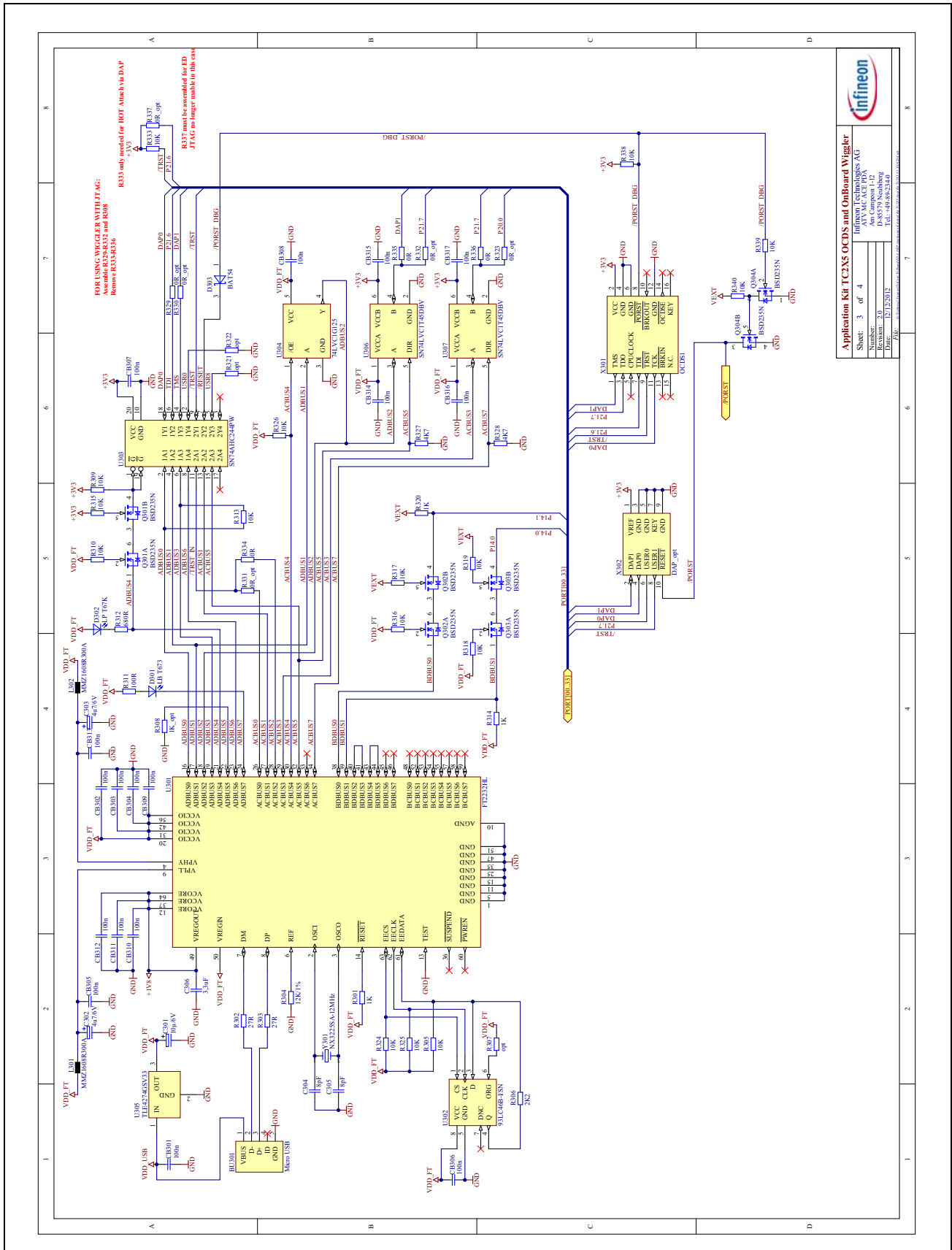

Figure 6-4 Schematic - miniWiggler JDS and OCDS1

6.2 Layout

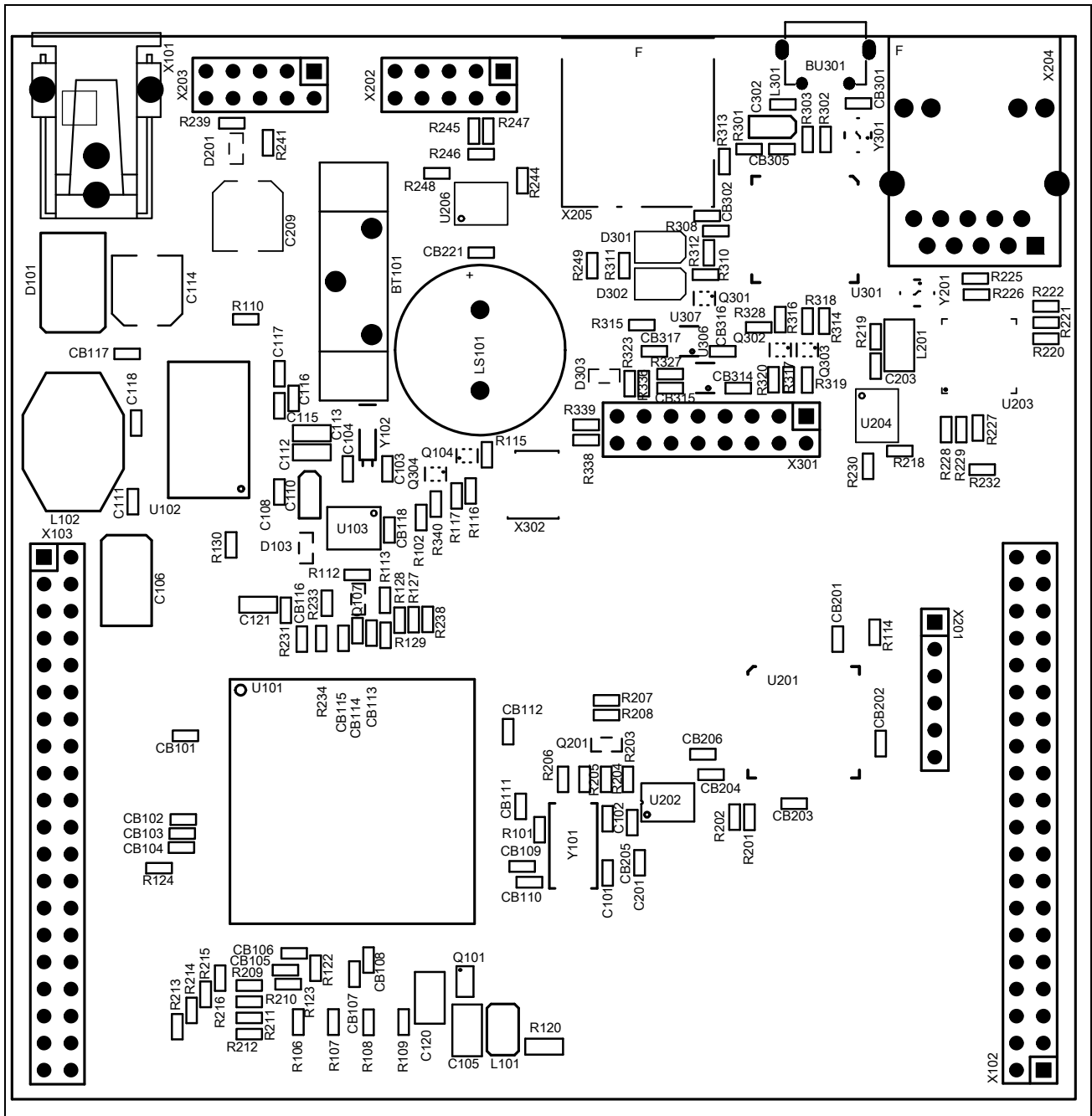

Figure 6-5 Component Plot Top Layer

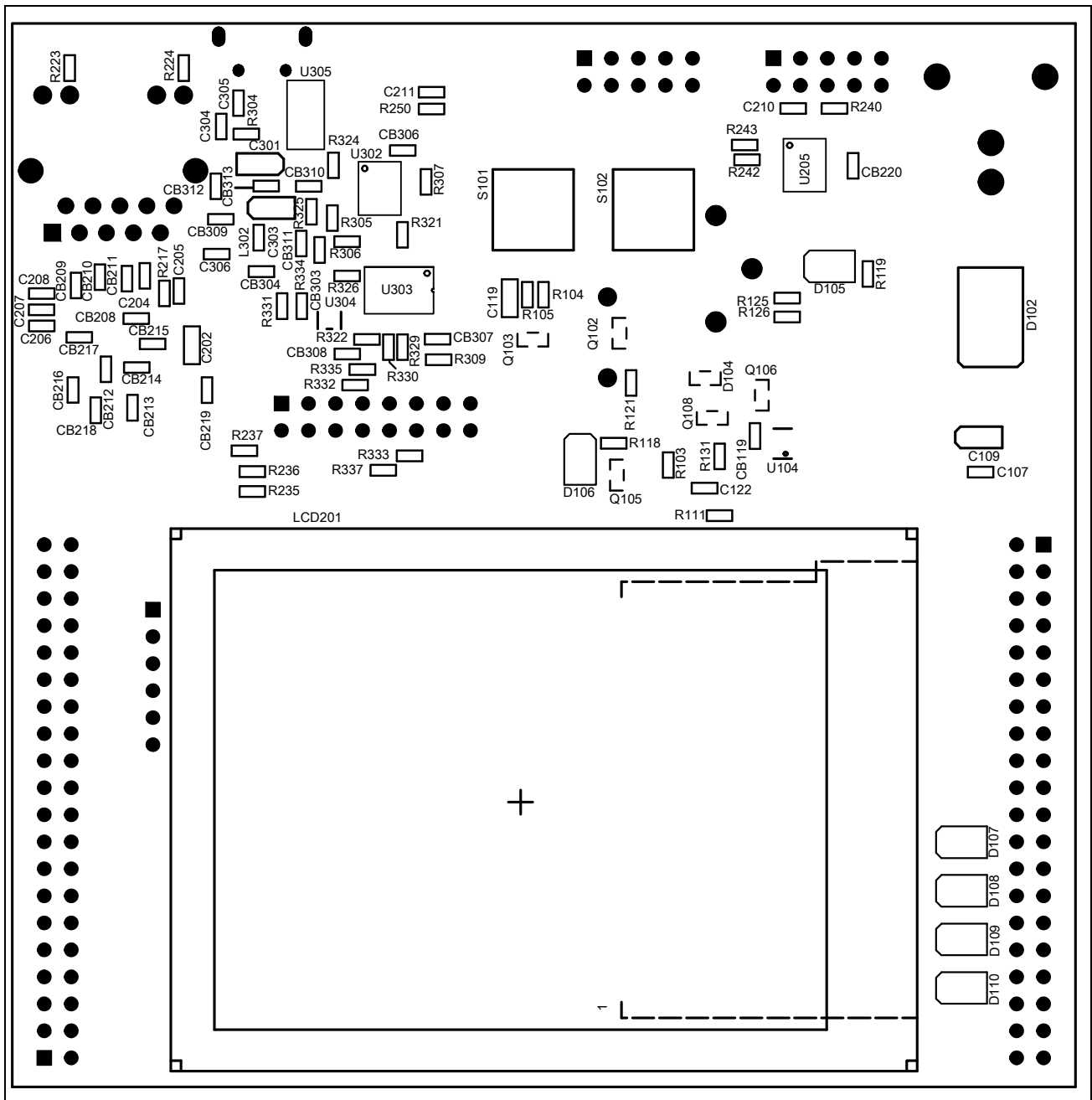

Figure 6-6 Component Plot Bottom Layer

Schematic and Layout

6.3 Layout with Dimensioning

The following dimensions should be used for development of extension boards.

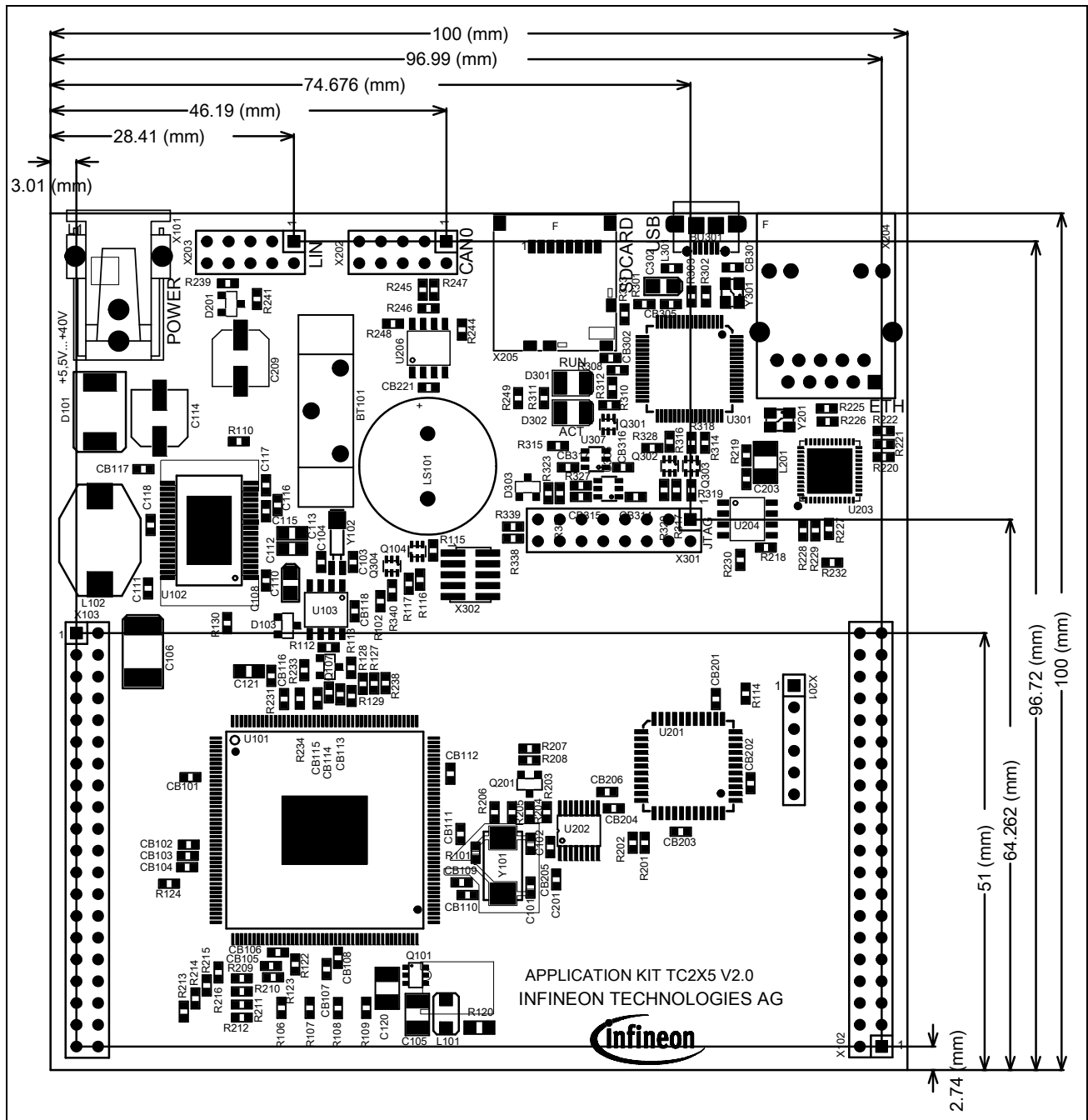

Figure 6-7 Dimensioning (mm)

Downloaded by mohamedomar.triki@infineon.com 09/08/2019 14:06:40

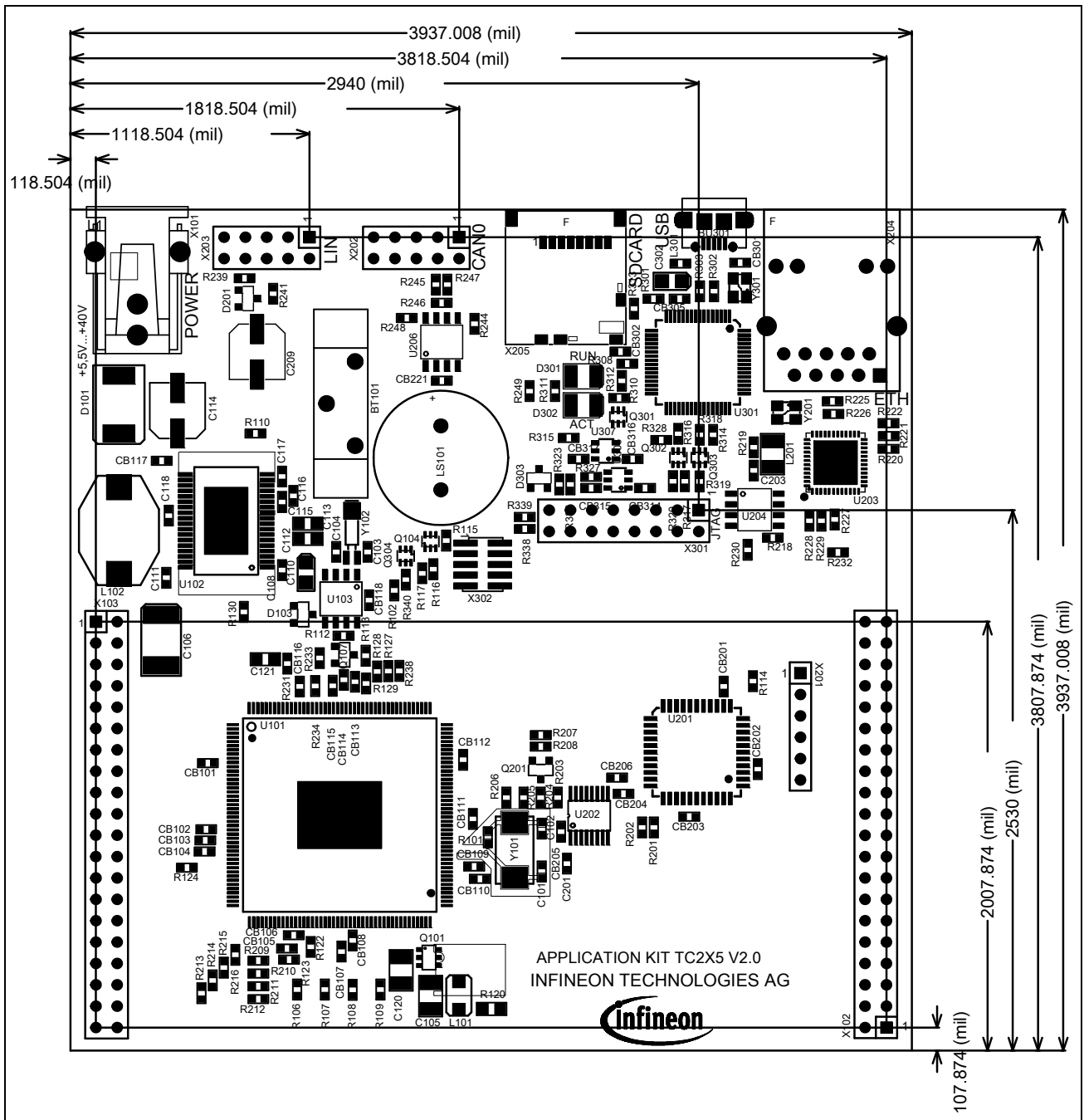

Figure 6-8 Dimensioning (mil)

Keyword Index

A

ACTIV LED 3-4

B

Beeper 3-5

C

CAN connector pinout 5-2

Clock 3-4

Clock Signals 4-2

Connector Pin Assignment 5-1
crystal 3-4

D

DAP connector pinout 5-4

Debug Signals 4-2

Debug System 3-5

Dimensioning 6-8

E

Ethernet 3-5

Ethernet Connector 5-4

F

Flexray Pinout 5-2

H

HSCT socket pinout 5-3

I

Interrupt Signals 4-1

L

Layout 6-6

LEDs 3-3

LIN 3-5

LIN connector pinout 5-3

M

manual power on reset 3-1

Micro SD card 3-3

miniWiggler JDS 3-4

MultiCAN 3-5

O

OCDS connector pinout 5-3

OCDS1 3-5

Other peripherals 3-5

P

Peripheral Signals 4-2

Power connector pinout 5-2

power on reset 3-1

Power Signals 4-1

power supply 3-1

POWER UP 3-1

Power via supply connector 3-1

R

Read a display register 3-2

Real Time Clock 3-1

Reset Signals 4-1

RUN LED 3-4

S

Schematic 6-1

Schematic and Layout 6-1

Serial Connection to PC 3-4

Signal Description 4-1

START BUTTON 3-1

status LED 3-5

Supply 3-1

T

Toggle LED's 3-5

Touch controller 3-3

U

USB Connector 3-4

USB connector pinout 5-2

W

Write a display register 3-2

X

XGA Display 3-2

www.infineon.com

Published by Infineon Technologies AG

Downloaded From [Oneyac.com](https://www.oneyac.com)

单击下面可查看定价，库存，交付和生命周期等信息

[>>Infineon\(英飞凌\)](#)