

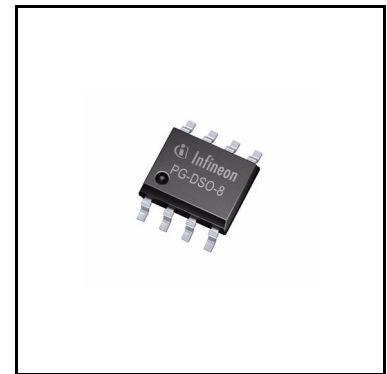
# BSP752R

## Smart High-Side Power Switch



### Features

- Overload protection
- Current limitation
- Short circuit protection
- Thermal shutdown with restart
- Overvoltage protection (including load dump)
- Fast demagnetization of inductive loads
- Reverse battery protection with external resistor
- Open drain diagnostic output for overtemperature and short circuit
- Open load detection in OFF-State with external resistor
- CMOS compatible input
- Loss of GND and loss of  $V_{bb}$  protection
- ESD - Protection
- Very low standby current
- AEC Qualified
- Green Product (RoHS compliant)



PG-DSO-8

### Applications

- All types of resistive, inductive and capacitive loads
- $\mu$ C compatible power switch for 12V, 24V and 42V DC applications
- Replaces electromechanical relays and discrete circuits

### Description

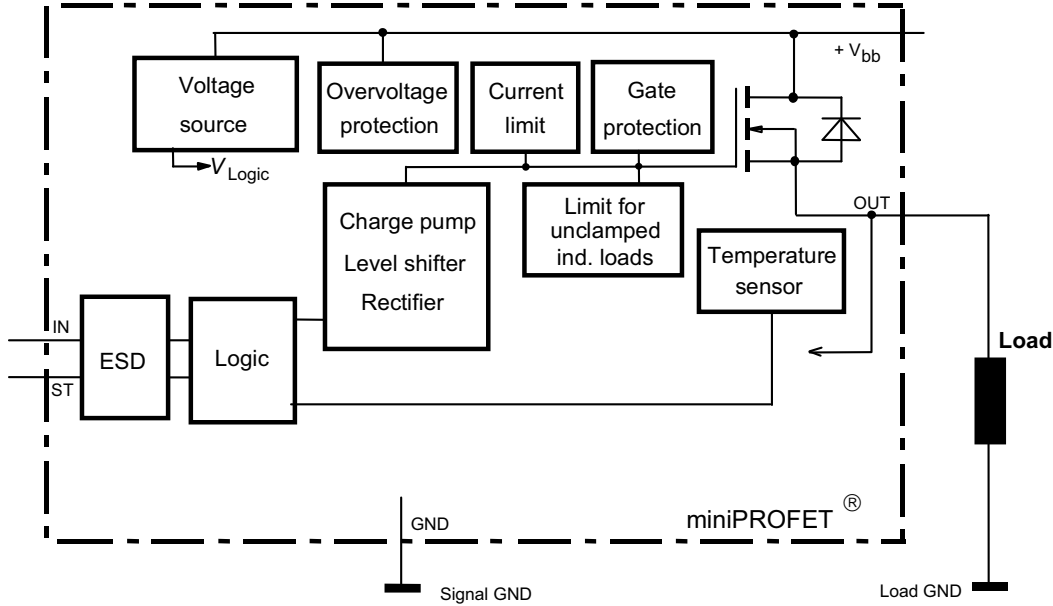
N Channel vertical power FET with charge pump, ground referenced CMOS compatible input and diagnostic feedback, monolithically integrated in Smart SIPMOS<sup>®</sup> technology.

Providing embedded protective functions.

**Table 1 Product Summary**

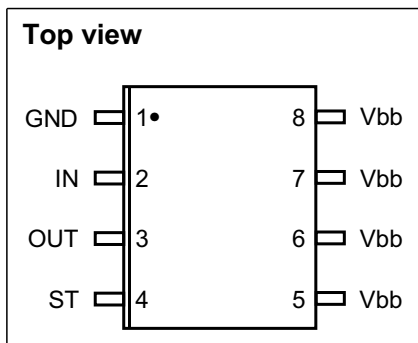
| Parameter              | Symbol       | Values         |
|------------------------|--------------|----------------|
| Overvoltage protection | $V_{bb(AZ)}$ | 62 V           |
| Operating voltage      | $V_{DS(AZ)}$ | 6...52 V       |
| ON-State Resistance    | $R_{DS(ON)}$ | 200 m $\Omega$ |
| Nominal load current   | $I_{L(nom)}$ | 1.3 A          |

### Block Diagram



| Pin | Symbol | Function   |
|-----|--------|--|
| 1   | GND    | Logic ground   |
| 2   | IN     | Input, activates the power switch in case of logic high signal |
| 3   | OUT    | Output to the load   |
| 4   | ST     | Diagnostic feedback  |
| 5   | Vbb    | Positive power supply voltage                                  |
| 6   | Vbb    | Positive power supply voltage                                  |
| 7   | Vbb    | Positive power supply voltage                                  |
| 8   | Vbb    | Positive power supply voltage                                  |

### Pin configuration



**Maximum Ratings** at  $T_j = 25^\circ\text{C}$ , unless otherwise specified

| Parameter   | Symbol         | Value              | Unit             |
|---|----------------|--------------------|------------------|
| Supply voltage  | $V_{bb}$       | 52                 | V                |
| Supply voltage for full short circuit protection  | $V_{bb(SC)}$   | 50                 |                  |
| Continuous input voltage  | $V_{IN}$       | -10 ... +16        |                  |
| Load current (Short - circuit current, see page 5)  | $I_L$          | self limited       | A                |
| Current through input pin (DC)  | $I_{IN}$       | $\pm 5$            | mA               |
| Operating temperature   | $T_j$          | -40 ... +150       | $^\circ\text{C}$ |
| Storage temperature   | $T_{stg}$      | -55 ... +150       |                  |
| Power dissipation <sup>1)</sup>   | $P_{tot}$      | 1.5                | W                |
| Inductive load switch-off energy dissipation <sup>1)2)</sup><br>single pulse, (see page 9 )<br>$T_j = 150^\circ\text{C}$ , $I_L = 1\text{ A}$   | $E_{AS}$       | 125                | mJ               |
| Load dump protection <sup>2)</sup> $V_{LoadDump}^{3)} = V_A + V_S$<br>$R_I = 2\Omega$ , $t_d = 400\text{ms}$ , $V_{IN} = \text{low or high}$ , $V_A = 13,5\text{V}$<br>$R_L = 13.5\ \Omega$<br>$R_L = 27\ \Omega$ | $V_{Loaddump}$ | 73.5<br>83.5       | V                |
| <b>Electrostatic discharge voltage</b> (Human Body Model)<br>according to ANSI EOS/ESD - S5.1 - 1993<br>ESD STM5.1 - 1998<br>Input pin<br>all other pins  | $V_{ESD}$      | $\pm 1$<br>$\pm 5$ | kV               |

**Thermal Characteristics**

|   |              |   |    |    |     |
|---|--------------|---|----|----|-----|
| Thermal resistance @ min. footprint                               | $R_{th(JA)}$ | - | 95 | -  | K/W |
| Thermal resistance @ 6 cm <sup>2</sup> cooling area <sup>1)</sup> | $R_{th(JA)}$ | - | 70 | 83 |     |

<sup>1)</sup> Device on 50mm\*50mm\*1.5mm epoxy PCB FR4 with 6 cm<sup>2</sup> (one layer, 70µm thick) copper area for drain connection. PCB is vertical without blown air. (see page 17)

<sup>2)</sup> not subject to production test, specified by design

<sup>3)</sup>  $V_{Loaddump}$  is setup without the DUT connected to the generator per ISO 7637-1 and DIN 40839 .

Supply voltages higher than  $V_{bb(AZ)}$  require an external current limit for the GND pin, e.g. with a 150Ω resistor in GND connection. A resistor for the protection of the input is integrated.

### Electrical Characteristics

| Parameter and Conditions   | Symbol | Values |      |      | Unit |
|--|--------|--------|------|------|------|
|  |        | min.   | typ. | max. |      |
| at $T_j = -40...+150^\circ\text{C}$ , $V_{bb} = 12..42\text{V}$ , unless otherwise specified |        |        |      |      |      |

### Load Switching Capabilities and Characteristics

|  |                |     |     |     |                  |
|--|----------------|-----|-----|-----|------------------|
| On-state resistance<br>$T_j = 25^\circ\text{C}$ , $I_L = 1\text{ A}$ , $V_{bb} = 9...52\text{ V}$<br>$T_j = 150^\circ\text{C}$ | $R_{ON}$       | -   | 150 | 200 | m $\Omega$       |
|  |                | -   | 270 | 380 |                  |
| Nominal load current; Device on PCB <sup>1)</sup><br>$T_C = 85^\circ\text{C}$ , $T_j \leq 150^\circ\text{C}$                   | $I_{L(nom)}$   | 1.3 | 1.7 | -   | A                |
| Turn-on time to 90% $V_{OUT}$<br>$R_L = 47\ \Omega$  | $t_{on}$       | -   | 80  | 180 | $\mu\text{s}$    |
| Turn-off time to 10% $V_{OUT}$<br>$R_L = 47\ \Omega$   | $t_{off}$      | -   | 80  | 200 |                  |
| Slew rate on 10 to 30% $V_{OUT}$ ,<br>$R_L = 47\ \Omega$ , $V_{bb} = 13.5\text{ V}$  | $dV/dt_{on}$   | -   | 0.7 | 2   | V/ $\mu\text{s}$ |
| Slew rate off 70 to 40% $V_{OUT}$ ,<br>$R_L = 47\ \Omega$ , $V_{bb} = 13.5\text{ V}$   | $-dV/dt_{off}$ | -   | 0.9 | 2   |                  |

### Operating Parameters

|   |                 |   |     |     |               |
|---|-----------------|---|-----|-----|---------------|
| Operating voltage   | $V_{bb(on)}$    | 6 | -   | 52  | V             |
| Undervoltage shutdown of charge pump<br>$T_j = -40...+85^\circ\text{C}$<br>$T_j = 150^\circ\text{C}$                                | $V_{bb(under)}$ | - | -   | 4   |               |
|   |                 | - | -   | 5.5 |               |
| Undervoltage restart of charge pump   | $V_{bb(u\ cp)}$ | - | 4   | 5.5 |               |
| Standby current<br>$T_j = -40...+85^\circ\text{C}$ , $V_{IN} = \text{low}$<br>$T_j = +150^\circ\text{C}^2)$ , $V_{IN} = \text{low}$ | $I_{bb(off)}$   | - | -   | 15  | $\mu\text{A}$ |
|   |                 | - | -   | 18  |               |
| Leakage output current (included in $I_{bb(off)}$ )<br>$V_{IN} = \text{low}$  | $I_{L(off)}$    | - | -   | 5   |               |
| Operating current<br>$V_{IN} = \text{high}$   | $I_{GND}$       | - | 0.8 | 2   | mA            |

<sup>1</sup>Device on 50mm\*50mm\*1.5mm epoxy PCB FR4 with 6 cm<sup>2</sup> (one layer, 70 $\mu\text{m}$  thick) copper area for drain connection. PCB is vertical without blown air. (see page 17)

<sup>2</sup>higher current due temperature sensor

### Electrical Characteristics

| Parameter and Conditions<br>at $T_j = -40\dots+150^\circ\text{C}$ , $V_{bb} = 12..42\text{V}$ , unless otherwise specified   | Symbol                     | Values           |                                  |                  | Unit             |
|--|----------------------------|------------------|----------------------------------|------------------|------------------|
|  |                            | min.             | typ.                             | max.             |                  |
| <b>Protection Functions<sup>1)</sup></b>   |                            |                  |                                  |                  |                  |
| Initial peak short circuit current limit (pin 5 to 3)<br>$T_j = -40^\circ\text{C}$ , $V_{bb} = 20\text{V}$ , $t_m = 150\ \mu\text{s}$<br>$T_j = 25^\circ\text{C}$<br>$T_j = 150^\circ\text{C}$<br>$T_j = -40\dots+150^\circ\text{C}$ , $V_{bb} > 40\text{V}$ , ( see page 12 ) | $I_{L(\text{SCp})}$        | -<br>-<br>4<br>- | -<br>6.5<br>-<br>5 <sup>2)</sup> | 9<br>-<br>-<br>- | A                |
| Repetitive short circuit current limit<br>$T_j = T_{jt}$ (see timing diagrams)<br>$V_{bb} < 40\text{V}$<br>$V_{bb} > 40\text{V}$   | $I_{L(\text{SCr})}$        | -<br>-           | 6<br>4.5                         | -<br>-           |                  |
| Output clamp (inductive load switch off)<br>at $V_{\text{OUT}} = V_{bb} - V_{\text{ON}(\text{CL})}$ ,<br>$I_{bb} = 4\text{mA}$   | $V_{\text{ON}(\text{CL})}$ | 59               | 63                               | -                | V                |
| Oversvoltage protection <sup>3)</sup><br>$I_{bb} = 4\text{mA}$   | $V_{bb(\text{AZ})}$        | 62               | -                                | -                |                  |
| Thermal overload trip temperature  | $T_{jt}$                   | 150              | -                                | -                | $^\circ\text{C}$ |
| Thermal hysteresis   | $\Delta T_{jt}$            | -                | 10                               | -                | K                |

### Reverse Battery

|   |                  |   |     |    |    |
|---|------------------|---|-----|----|----|
| Reverse battery <sup>4)</sup>   | $-V_{bb}$        | - | -   | 52 | V  |
| Drain-source diode voltage ( $V_{\text{OUT}} > V_{bb}$ )<br>$T_j = 150^\circ\text{C}$ | $-V_{\text{ON}}$ | - | 600 | -  | mV |

<sup>1)</sup>Integrated protection functions are designed to prevent IC destruction under fault conditions described in the data sheet. Fault conditions are considered as "outside" normal operating range. Protection functions are not designed for continuous repetitive operation.

<sup>2)</sup>not subject to production test, specified by design

<sup>3)</sup> see also  $V_{\text{ON}(\text{CL})}$  in circuit diagram on page 8

<sup>4)</sup>Requires a  $150\ \Omega$  resistor in GND connection. The reverse load current through the intrinsic drain-source diode has to be limited by the connected load. Power dissipation is higher compared to normal operating conditions due to the voltage drop across the drain-source diode. The temperature protection is not active during reverse current operation! Input current has to be limited (see max. ratings page 3).

### Electrical Characteristics

| Parameter<br>at $T_j = -40...+150^\circ\text{C}$ , $V_{bb} = 12..42\text{V}$ , unless otherwise specified | Symbol | Values |      |      | Unit |
|---|--------|--------|------|------|------|
|   |        | min.   | typ. | max. |      |

#### Input and Status feedback

|  |                    |     |     |            |                  |
|--|--------------------|-----|-----|------------|------------------|
| Input turn-on threshold voltage  | $V_{IN(T+)}$       | -   | -   | 2.2        | V                |
| Input turn-off threshold voltage   | $V_{IN(T-)}$       | 0.8 | -   | -          |                  |
| Input threshold hysteresis   | $\Delta V_{IN(T)}$ | -   | 0.4 | -          |                  |
| Off state input current<br>$V_{IN} = 0.7\text{ V}$   | $I_{IN(off)}$      | 1   | -   | 25         | $\mu\text{A}$    |
| On state input current<br>$V_{IN} = 5\text{ V}$  | $I_{IN(on)}$       | 3   | -   | 25         |                  |
| Status output (open drain), Zener limit voltage<br>$I_{ST} = 1.6\text{ mA}$  | $V_{ST(high)}$     | 5.4 | 6.1 | -          | V                |
| Status output (open drain), ST low voltage<br>$T_j = -40...+25^\circ\text{C}$ , $I_{ST} = 1.6\text{ mA}$<br>$T_j = 150^\circ\text{C}$ , $I_{ST} = 1.6\text{ mA}$ | $V_{ST(low)}$      | -   | -   | 0.4<br>0.6 |                  |
| Status invalid after positive input slope <sup>1)</sup><br>$V_{bb} = 20\text{ V}$  | $t_{d(ST+)}$       | -   | 120 | 160        | $\mu\text{s}$    |
| Status invalid after negative input slope <sup>1)</sup>  | $t_{d(ST-)}$       | -   | 250 | 400        |                  |
| Input resistance (see page 8)  | $R_I$              | 2   | 3.5 | 5          | $\text{k}\Omega$ |

#### Diagnostic Characteristics

|  |               |   |     |   |                  |
|--|---------------|---|-----|---|------------------|
| Short circuit detection voltage  | $V_{OUT(SC)}$ | - | 2.8 | - | V                |
| Open load detection voltage <sup>2)</sup>  | $V_{OUT(OL)}$ | - | 3   | 4 |                  |
| Internal output pull down <sup>3)</sup><br>( see page 9 and 14 )<br>$V_{OUT(OL)} = 4\text{ V}$ | $R_O$         | - | 200 | - | $\text{k}\Omega$ |

<sup>1)</sup>no delay time after overtemperature switch off and short circuit in on-state

<sup>2)</sup>External pull up resistor required for open load detection in off state.

<sup>3)</sup>not subject to production test, specified by design

|  | Input level | Output level | Status              |
|--|-------------|--------------|---------------------|
| Normal operation                         | L           | L            | H                   |
|  | H           | H            | H                   |
| Short circuit to GND                     | L           | L            | H                   |
|  | H           | L *          | L                   |
| Short circuit to $V_{bb}$ (in off-state) | L           | H            | L                   |
|  | H           | H            | H                   |
| Overload                                 | L           | L            | H                   |
|  | H           | H **         | H                   |
| Overtemperature                          | L           | L            | H                   |
|  | H           | L            | L                   |
| Open Load in off-state                   | L           | Z            | H (L <sup>1</sup> ) |
|  | H           | H            | H                   |

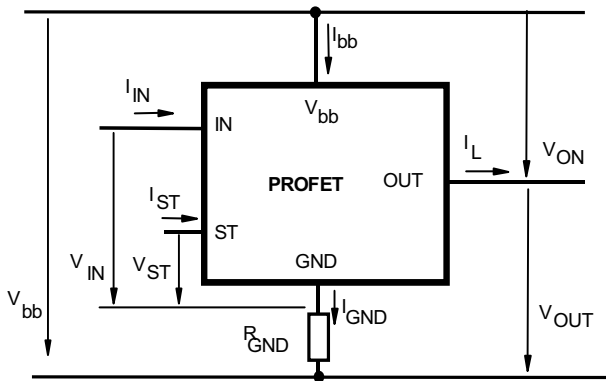
\*) Out ="L":  $V_{OUT} < 2.8V$  typ.

\*\*\*) Out ="H":  $V_{OUT} > 2.8V$  typ.

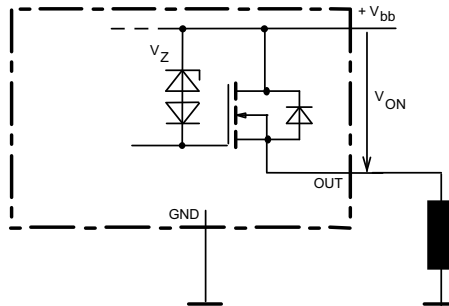
Z = high impedance, potential depends on external circuit

<sup>1</sup>with external resistor between  $V_{bb}$  and OUT

**Terms**

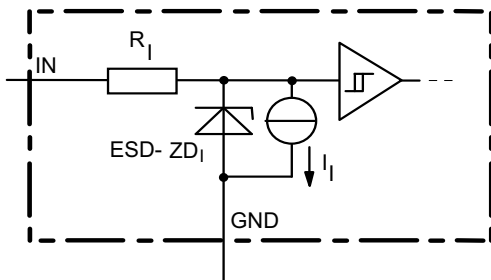


**Inductive and overvoltage output clamp**



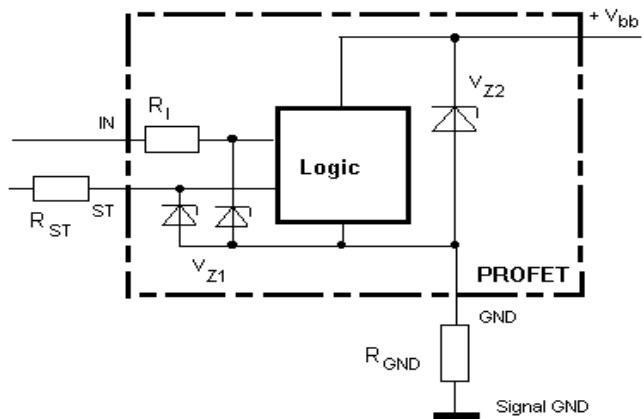
$V_{ON}$  clamped to 59V min.

**Input circuit (ESD protection)**



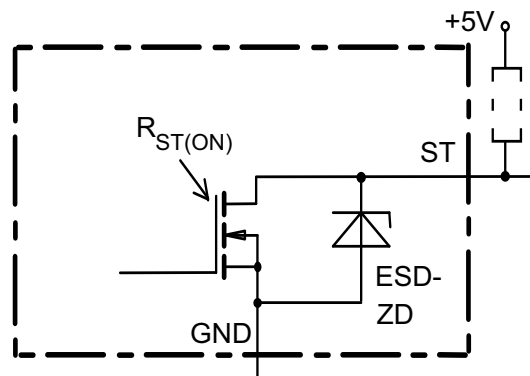
The use of ESD zener diodes as voltage clamp at DC conditions is not recommended

**Overvoltage protection of logic part**

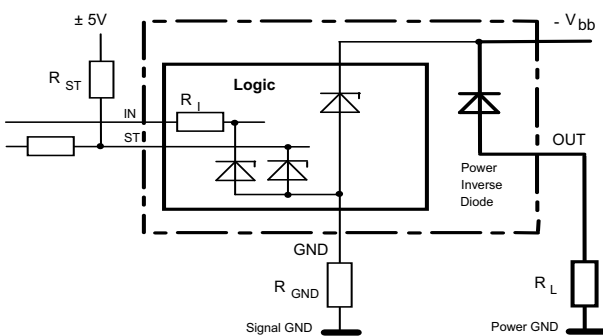


$V_{Z1}=6.1V$  typ.,  $V_{Z2}=V_{bb(AZ)}=62V$  min.,  
 $R_I=3.5\text{ k}\Omega$  typ.,  $R_{GND}=150\Omega$

**Status output**



**Reverse battery protection**

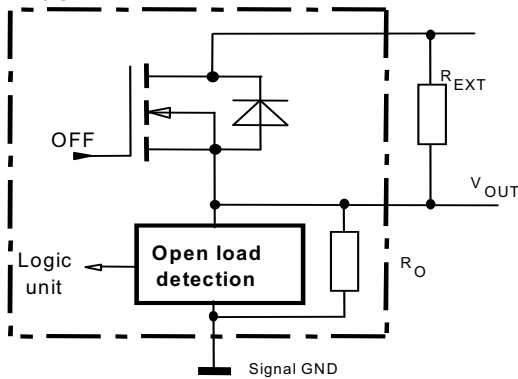


$R_{GND}=150\Omega$ ,  $R_I=3.5\text{ k}\Omega$  typ.,  
Temperature protection is not active during inverse current

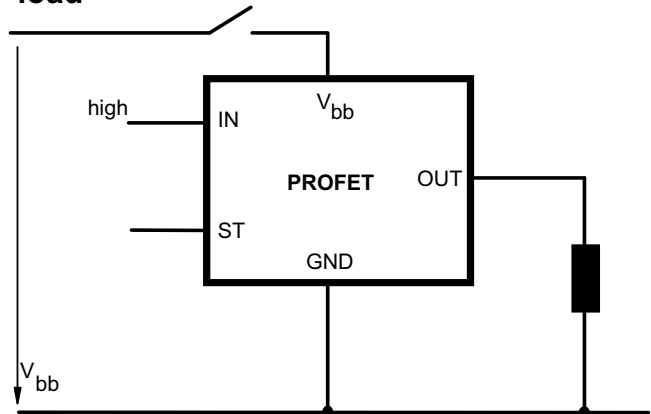


**Open-load detection**

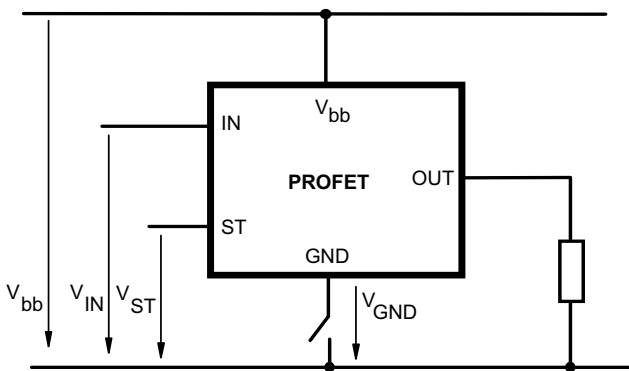
OFF-state diagnostic condition:  
 $V_{OUT} > 3V$  typ.;  $IN=low$



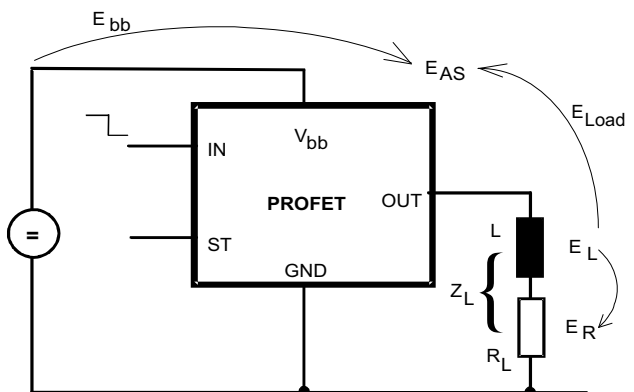
**$V_{bb}$  disconnect with charged inductive load**



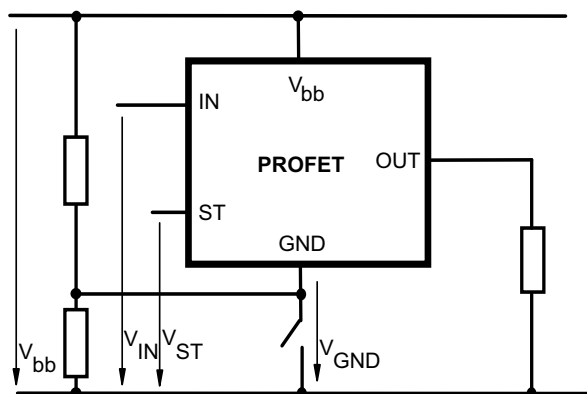
**GND disconnect**



**Inductive Load switch-off energy dissipation**



**GND disconnect with GND pull up**



Energy stored in load inductance:  $E_L = \frac{1}{2} * L * I_L^2$

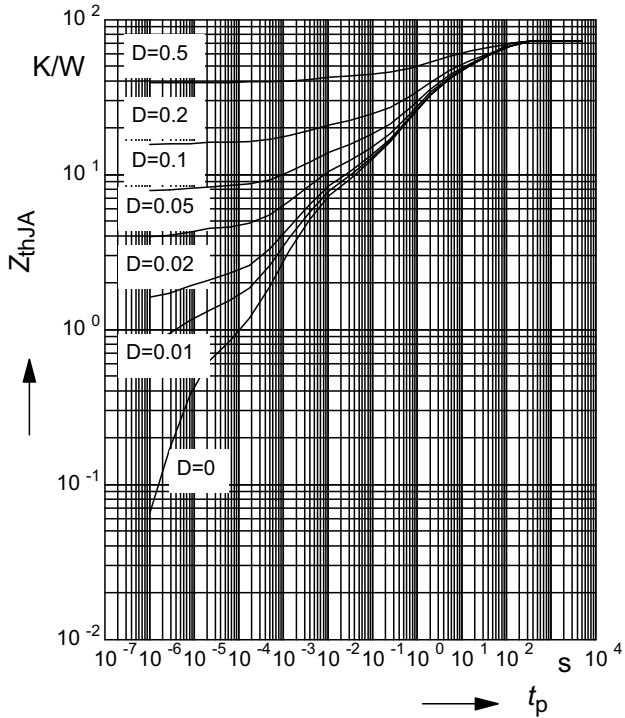
While demagnetizing load inductance, the energy dissipated in PROFET is  $E_{AS} = E_{bb} + E_L - E_R = V_{ON(CL)} * I_L(t) dt$ , with an approximate solution for  $R_L > 0\Omega$ :

$$E_{AS} = \frac{I_L * L}{2 * R_L} * (V_{bb} + |V_{OUT(CL)}|) * \ln\left(1 + \frac{I_L * R_L}{|V_{OUT(CL)}|}\right)$$

**Typ. transient thermal impedance**

$Z_{thJA} = f(t_p)$  @ 6cm<sup>2</sup> heatsink area

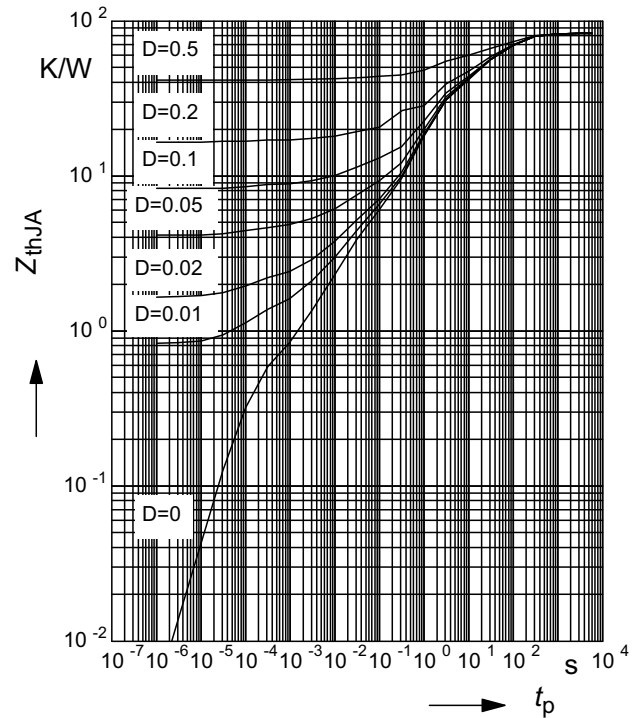
Parameter:  $D = t_p / T$



**Typ. transient thermal impedance**

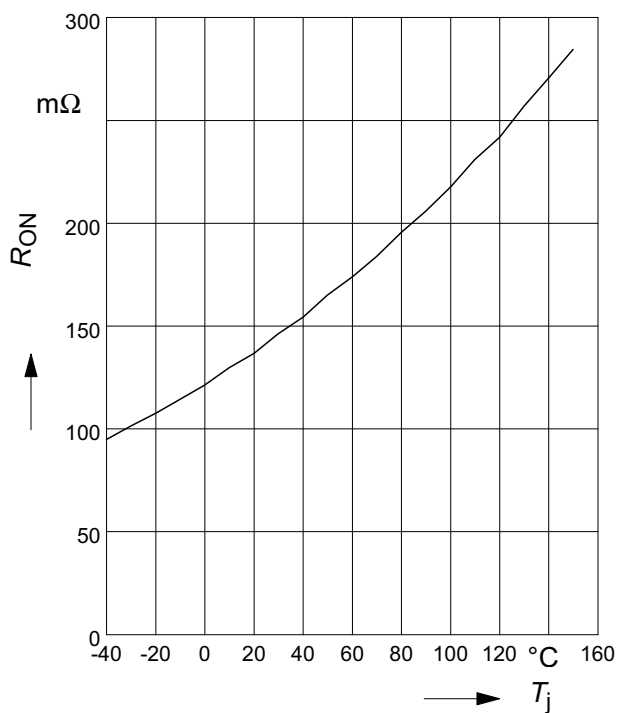
$Z_{thJA} = f(t_p)$  @ min. footprint

Parameter:  $D = t_p / T$



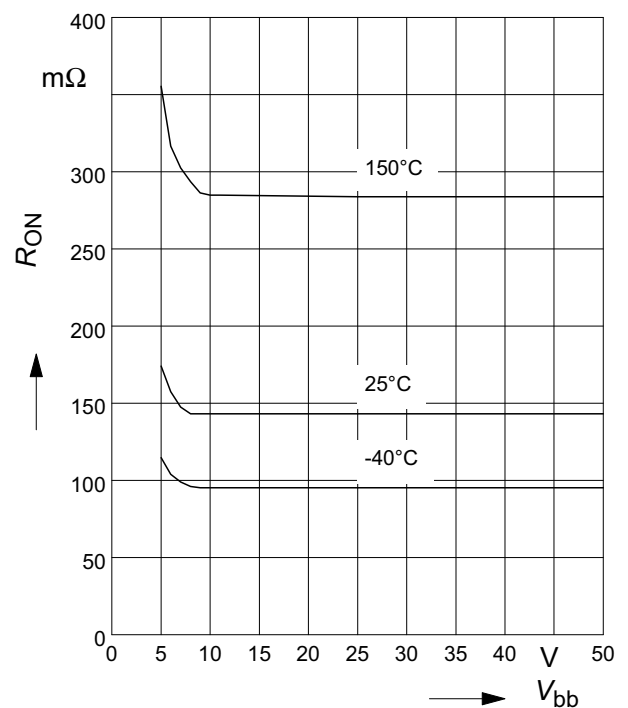
**Typ. on-state resistance**

$R_{ON} = f(T_j)$ ;  $V_{bb} = 13,5V$ ;  $V_{in} = \text{high}$



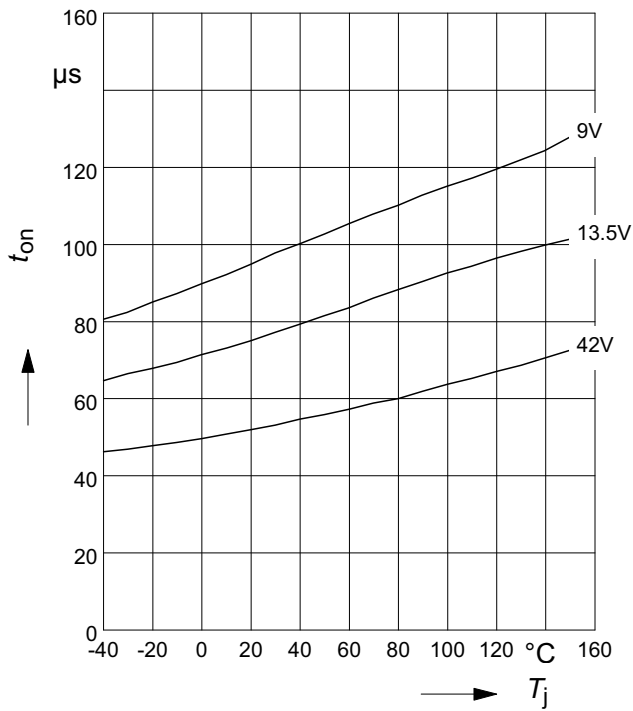
**Typ. on-state resistance**

$R_{ON} = f(V_{bb})$ ;  $I_L = 1 A$ ;  $V_{in} = \text{high}$



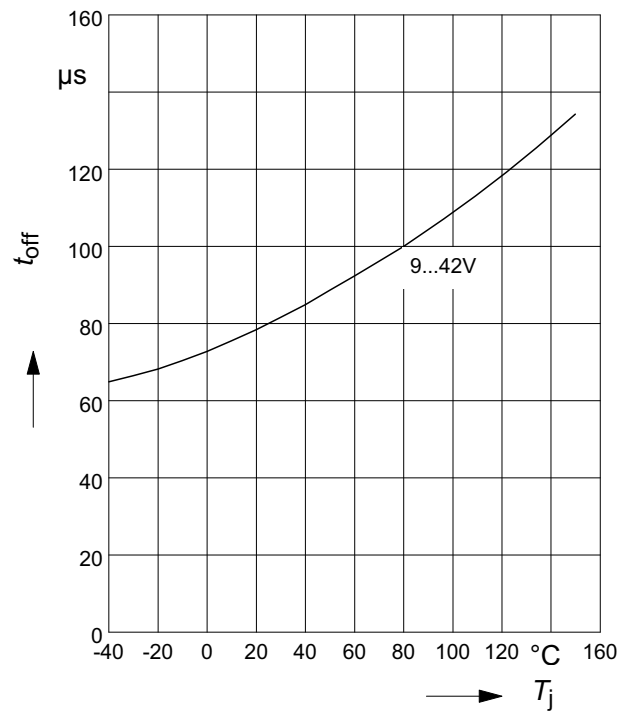
**Typ. turn on time**

$t_{on} = f(T_j); R_L = 47\Omega$



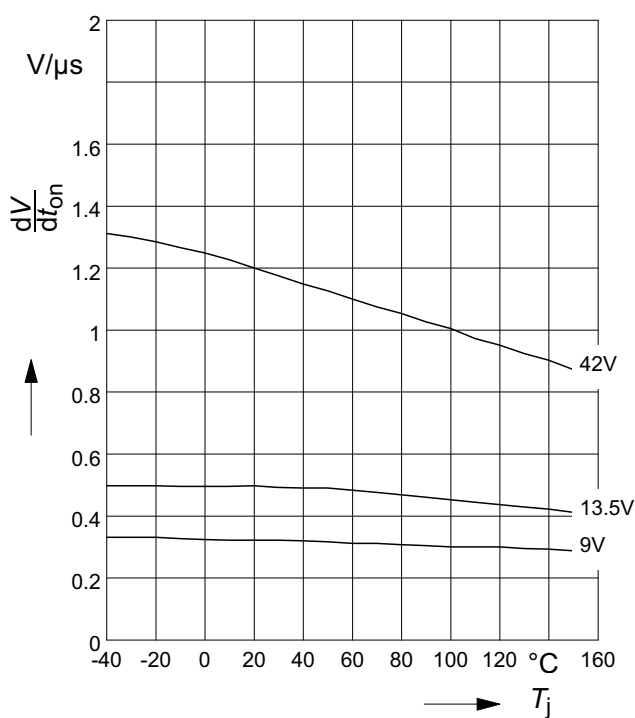
**Typ. turn off time**

$t_{off} = f(T_j); R_L = 47\Omega$



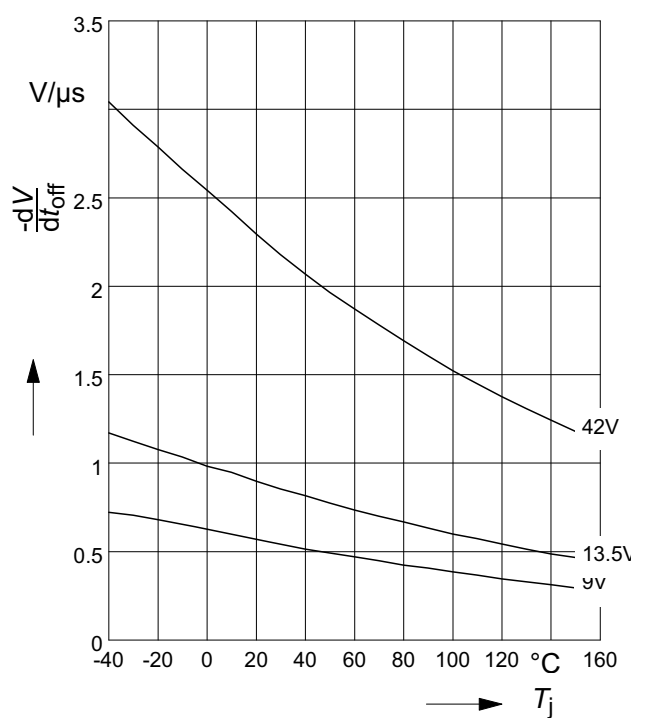
**Typ. slew rate on**

$dV/dt_{on} = f(T_j); R_L = 47\Omega$



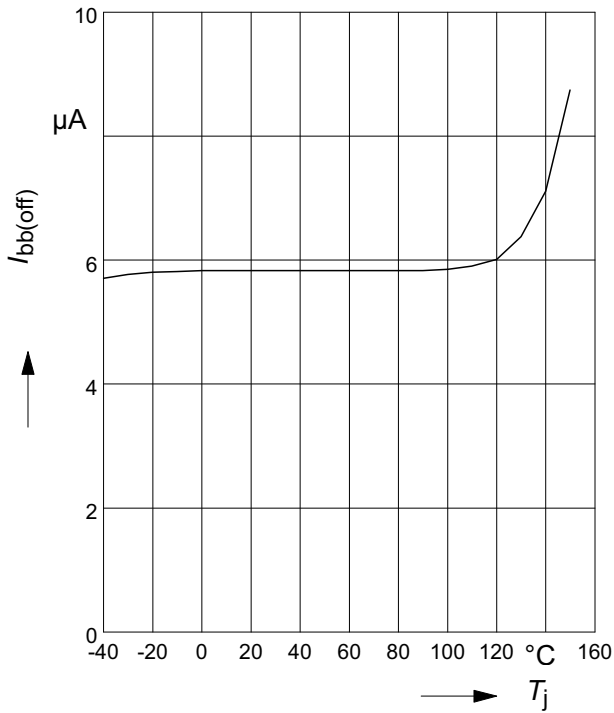
**Typ. slew rate off**

$dV/dt_{off} = f(T_j); R_L = 47\Omega$



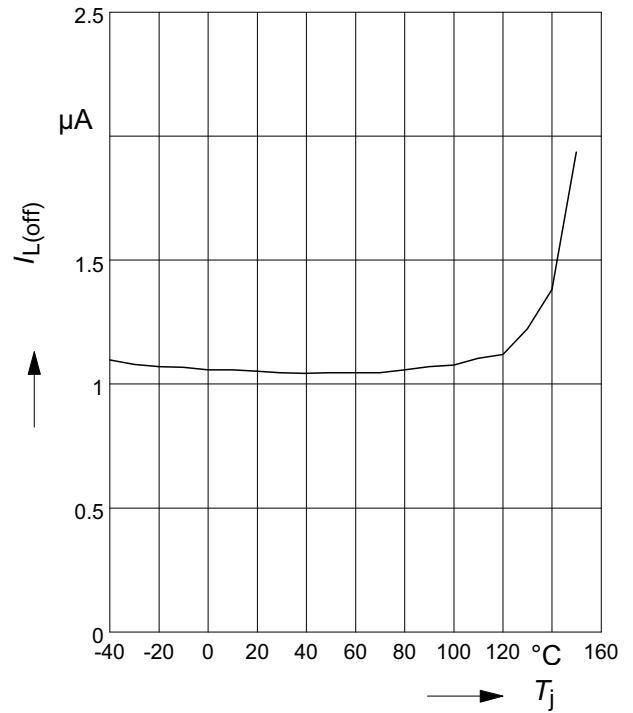
**Typ. standby current**

$I_{bb(off)} = f(T_j) ; V_{bb} = 42V ; V_{IN} = low$



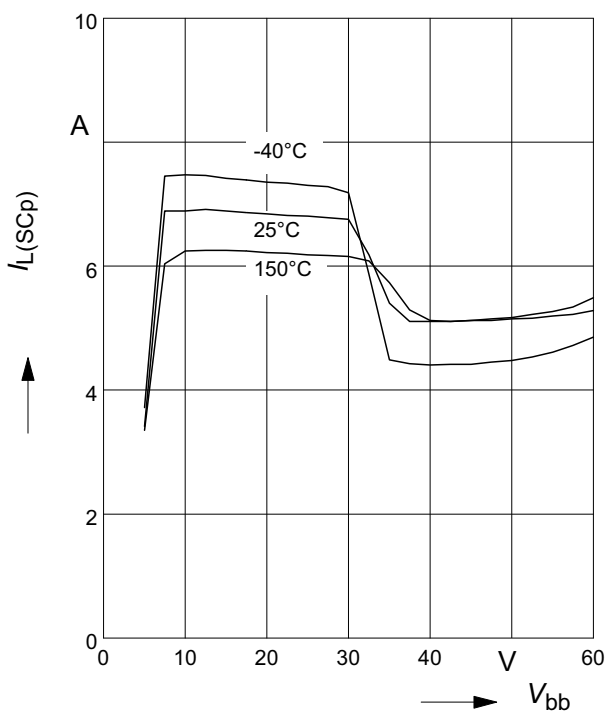
**Typ. leakage current**

$I_{L(off)} = f(T_j) ; V_{bb} = 42V ; V_{IN} = low$



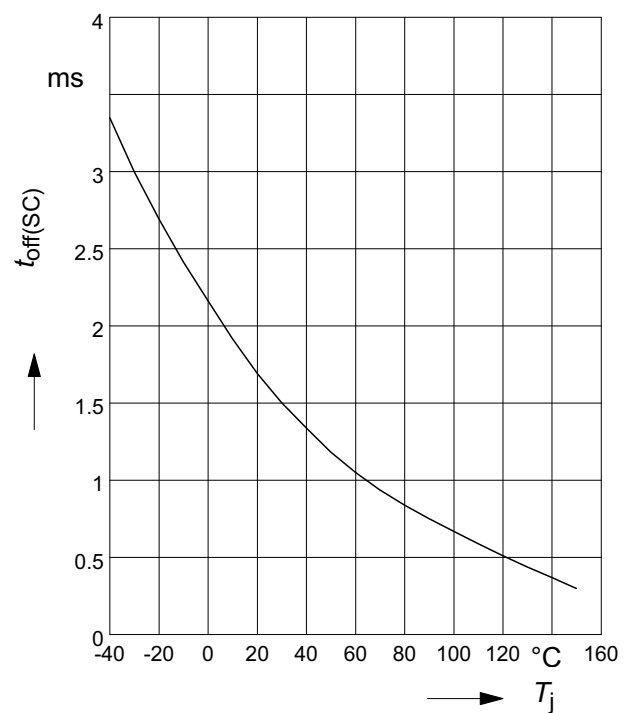
**Typ. initial peak short circuit current limit**

$I_{L(SCp)} = f(V_{bb})$



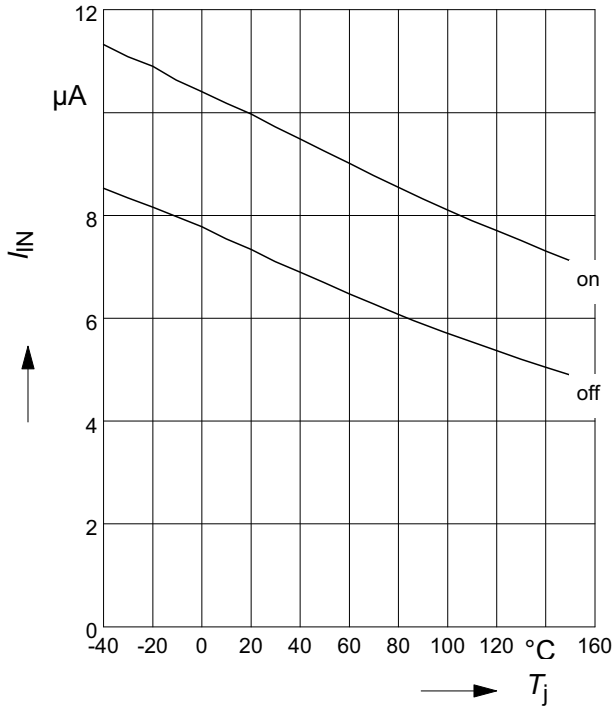
**Typ. initial short circuit shutdown time**

$t_{off(SC)} = f(T_{j,start}) ; V_{bb} = 20V$



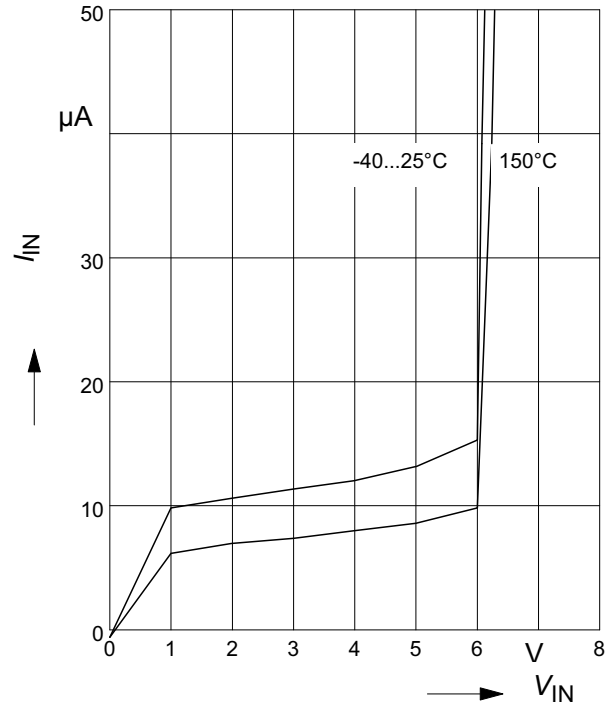
**Typ. input current**

$I_{IN(on/off)} = f(T_j)$ ;  $V_{bb} = 13,5V$ ;  $V_{IN} = \text{low/high}$   
 $V_{INlow} \leq 0,7V$ ;  $V_{INhigh} = 5V$



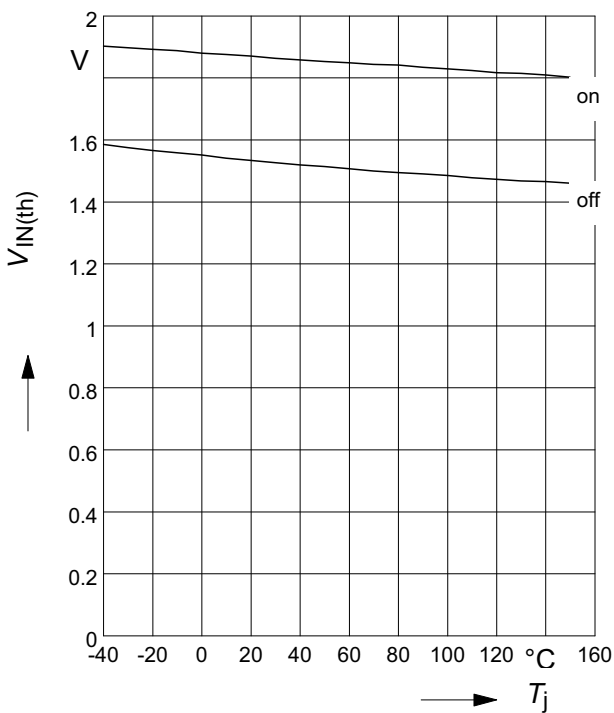
**Typ. input current**

$I_{IN} = f(V_{IN})$ ;  $V_{bb} = 13.5V$



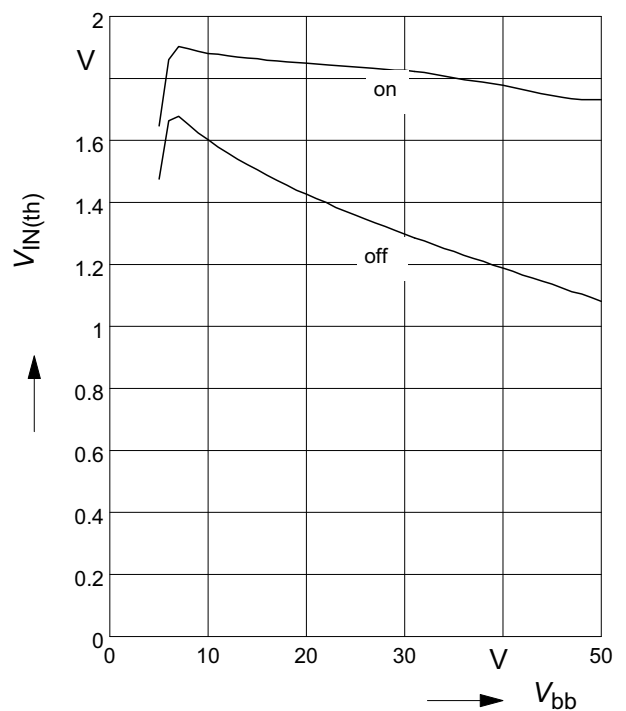
**Typ. input threshold voltage**

$V_{IN(th)} = f(T_j)$ ;  $V_{bb} = 13,5V$



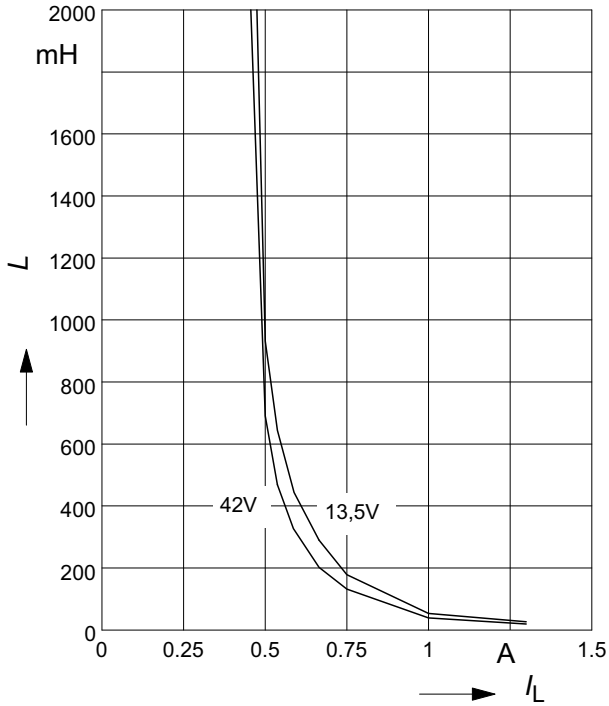
**Typ. input threshold voltage**

$V_{IN(th)} = f(V_{bb})$ ;  $T_j = 25^{\circ}C$



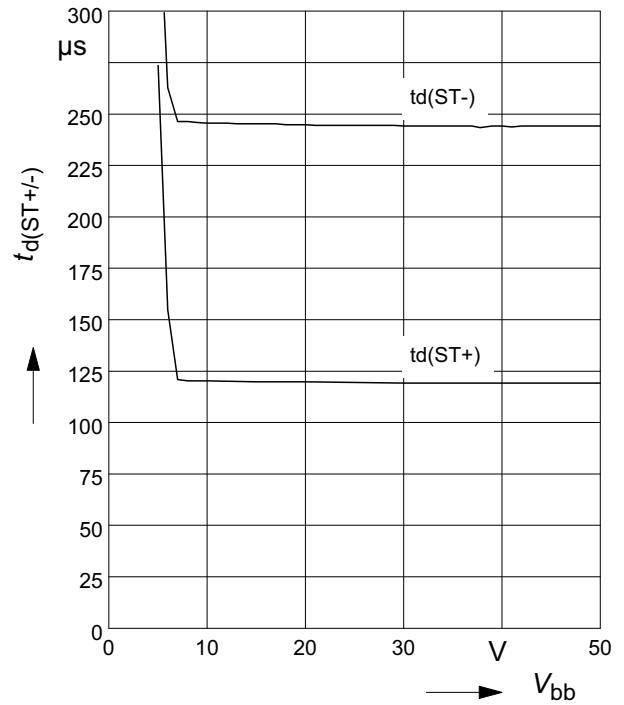
**Maximum allowable load inductance for a single switch off**

$L = f(I_L); T_{jstart}=150^{\circ}\text{C}, R_L=0\Omega$



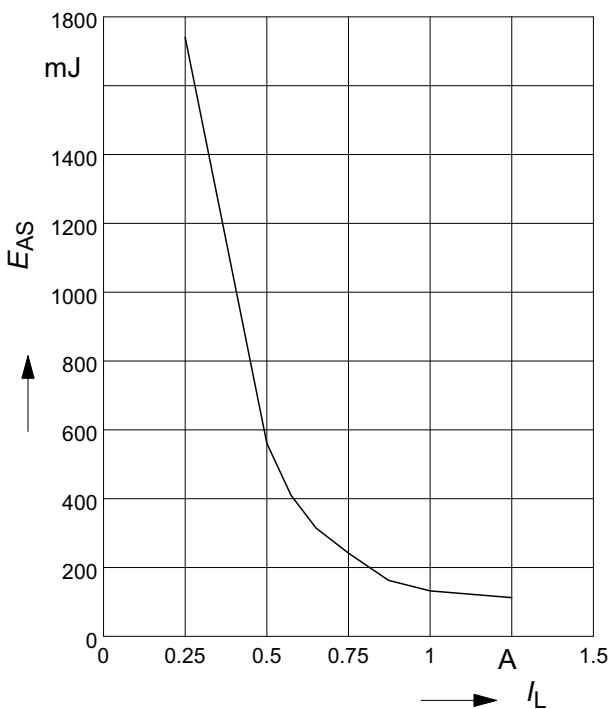
**Typ. status delay time**

$t_{d(ST)} = f(V_{bb}); T_j = 25^{\circ}\text{C}$



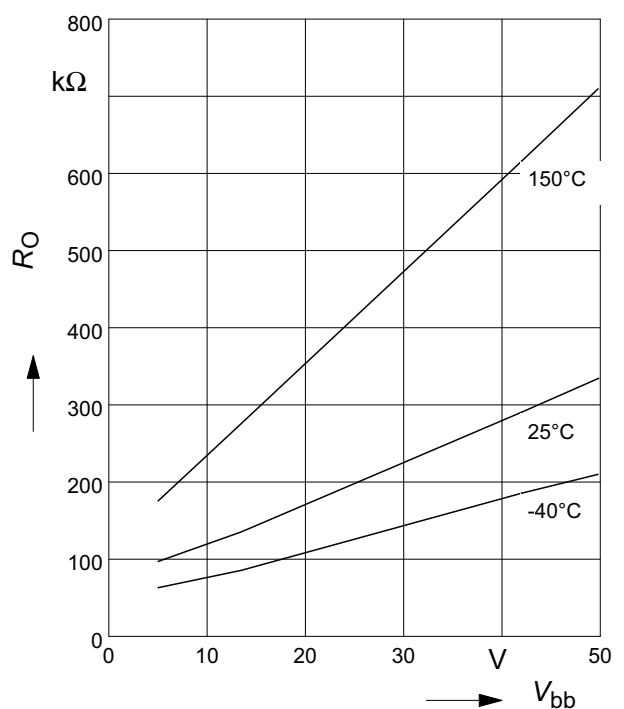
**Maximum allowable inductive switch-off energy, single pulse**

$E_{AS} = f(I_L); T_{jstart} = 150^{\circ}\text{C}, V_{bb} = 13,5\text{V}$



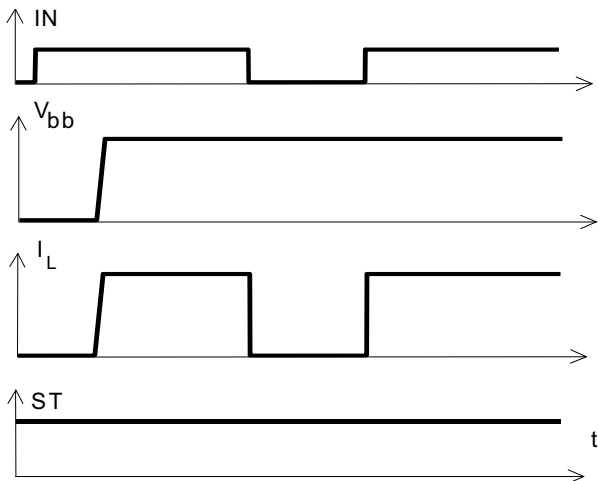
**Typ. internal output pull down**

$R_O = f(V_{bb})$

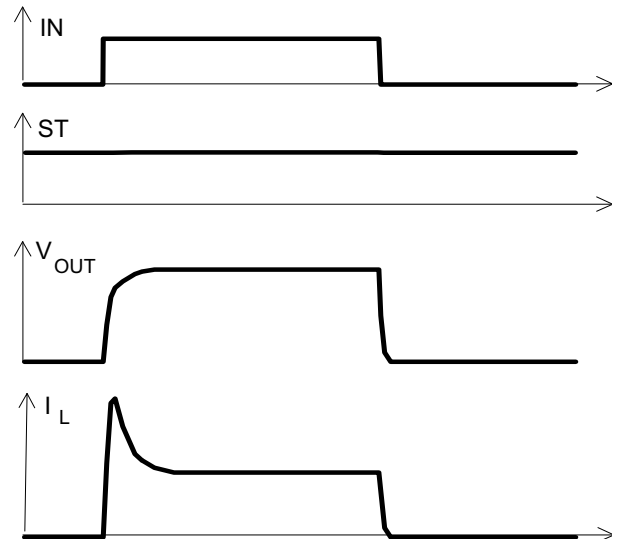


## Timing diagrams

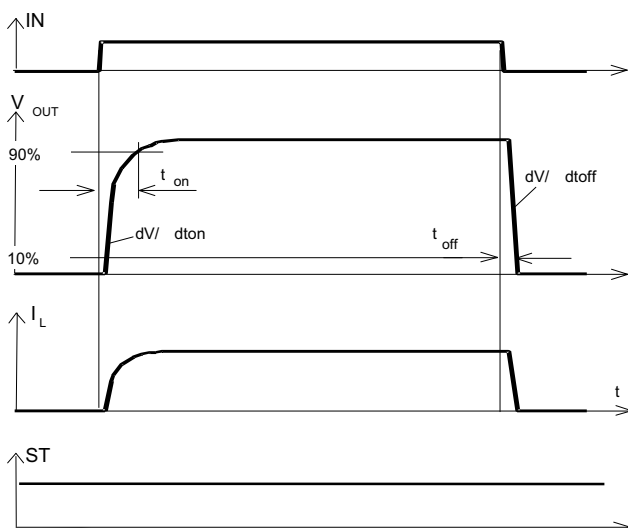
**Figure 1a:** V<sub>bb</sub> turn on:



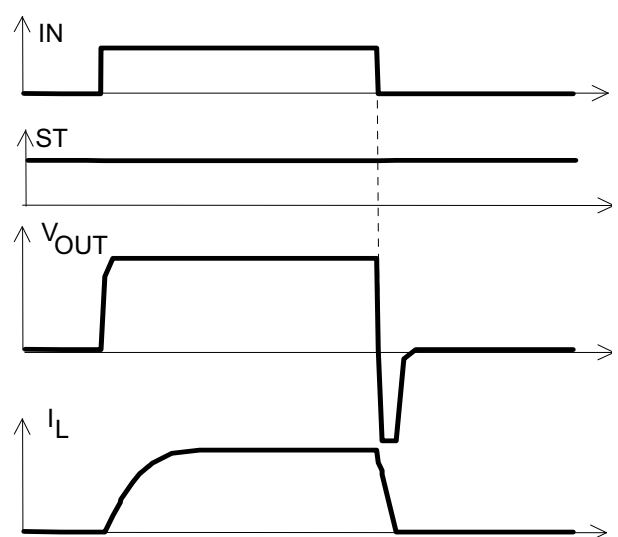
**Figure 2b:** Switching a lamp,



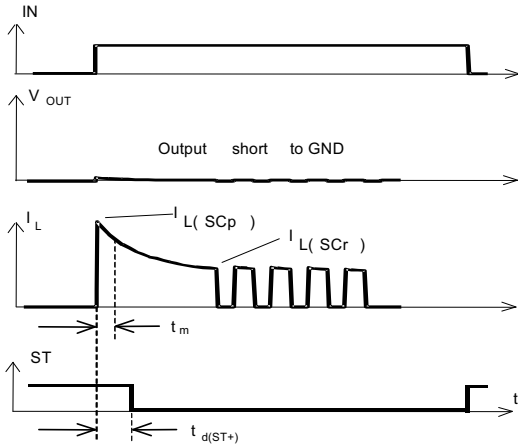
**Figure 2a:** Switching a resistive load, turn-on/off time and slew rate definition



**Figure 2c:** Switching an inductive load

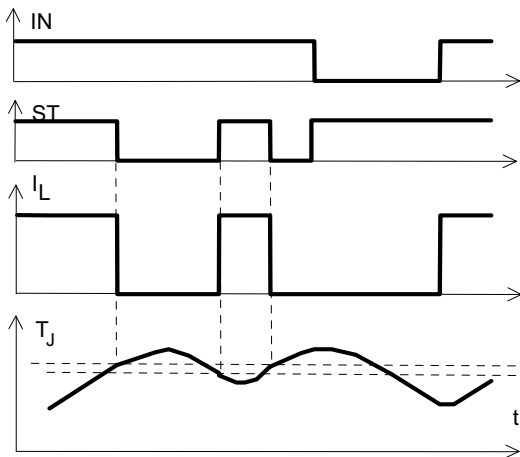


**Figure 3a:** Turn on into short circuit, shut down by overtemperature, restart by cooling

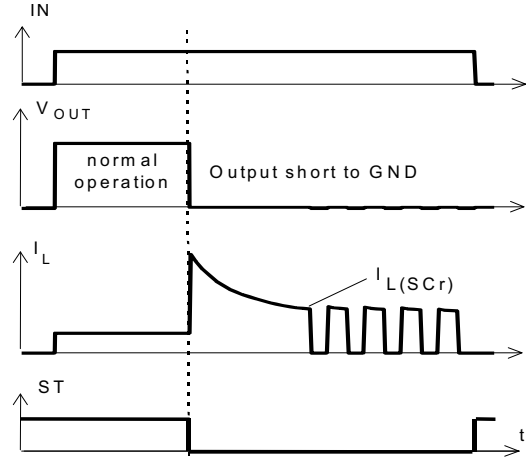


Heating up of the chip may require several milliseconds, depending on external conditions.

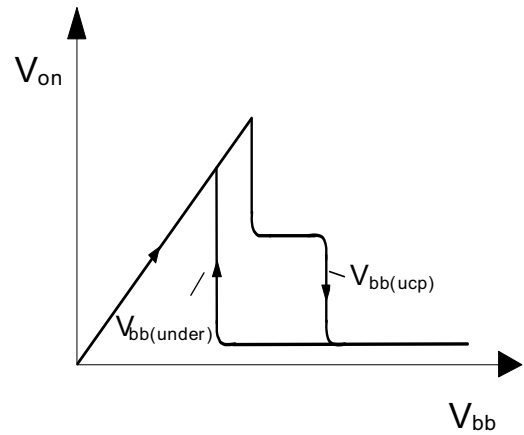
**Figure 4:** Overtemperature: Reset if  $T_j < T_{jt}$



**Figure 3b:** Short circuit in on-state shut down by overtemperature, restart by cooling

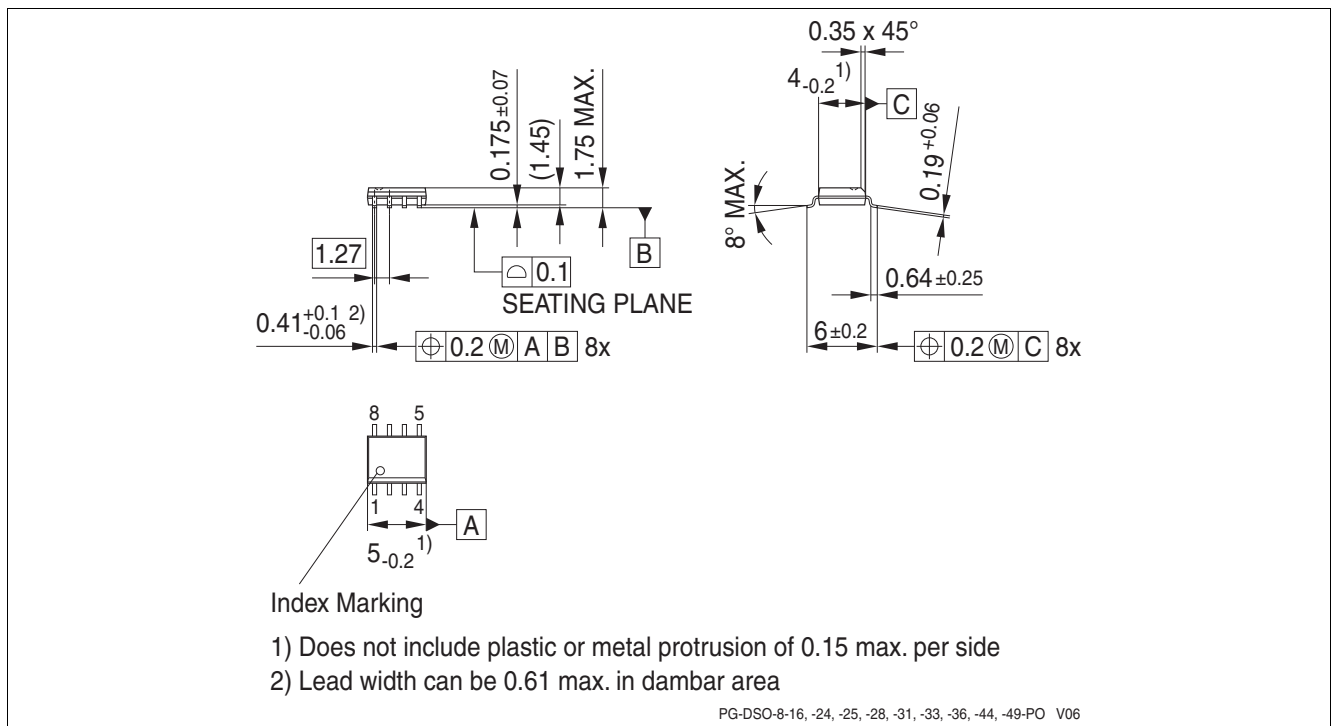


**Figure 5:** Undervoltage restart of charge pump





## Package Outlines



**Figure 1** PG-DSO-8-24 (Plastic Dual Small Outline Package) (RoHS-compliant)

To meet the world-wide customer requirements for environmentally friendly products and to be compliant with government regulations the device is available as a green product. Green products are RoHS-Compliant (i.e Pb-free finish on leads and suitable for Pb-free soldering according to IPC/JEDEC J-STD-020).

## Revision History

| Version | Date       | Changes  |
|---------|------------|--|
| V1.2    | 2016-02-22 | Update to latest template<br>Updated Package drawing<br>Added page 14  |
| V1.1    | 2007-05-29 | Creation of the green datasheet.<br>First page :<br>Adding the green logo and the AEC qualified<br>Adding the bullet AEC qualified and the RoHS compliant features<br>Package page<br>Modification of the package to be green. |

#### Trademarks of Infineon Technologies AG

$\mu$ HVIC™,  $\mu$ IPM™,  $\mu$ PFC™, AU-ConvertIR™, AURIX™, C166™, CanPAK™, CIPOS™, CIPURSE™, CoolDP™, CoolGaN™, COOLiR™, CoolMOS™, CoolSET™, CoolSiC™, DAVE™, DI-POL™, DirectFET™, DrBlade™, EasyPIM™, EconoBRIDGE™, EconoDUAL™, EconoPACK™, EconoPIM™, EiceDRIVER™, eupec™, FCOS™, GaNpowIR™, HEXFET™, HITFET™, HybridPACK™, iMOTION™, IRAM™, ISOFACE™, IsoPACK™, LEDriviR™, LITIX™, MIPAQ™, ModSTACK™, my-d™, NovalithIC™, OPTIGA™, OptiMOS™, ORIGA™, PowIRaudio™, PowIRstage™, PrimePACK™, PrimeSTACK™, PROFET™, PRO-SIL™, RASIC™, REAL3™, SmartLEWIS™, SOLID FLASH™, SPOC™, StrongIRFET™, SupIRBuck™, TEMPFET™, TRENCHSTOP™, TriCore™, UHVIC™, XHP™, XMC™.

Trademarks updated November 2015

#### Other Trademarks

All referenced product or service names and trademarks are the property of their respective owners.

**Edition 2016-02-22**

**Published by**

**Infineon Technologies AG**

**81726 Munich, Germany**

**© 2/23/16 Infineon Technologies AG.**

**All Rights Reserved.**

**Do you have a question about any aspect of this document?**

**Email: [erratum@infineon.com](mailto:erratum@infineon.com)**

#### IMPORTANT NOTICE

The information given in this document shall in no event be regarded as a guarantee of conditions or characteristics ("Beschaffenheitsgarantie").

With respect to any examples, hints or any typical values stated herein and/or any information regarding the application of the product, Infineon Technologies hereby disclaims any and all warranties and liabilities of any kind, including without limitation warranties of non-infringement of intellectual property rights of any third party.

In addition, any information given in this document is subject to customer's compliance with its obligations stated in this document and any applicable legal requirements, norms and standards concerning customer's products and any use of the product of Infineon Technologies in customer's applications.

The data contained in this document is exclusively intended for technically trained staff. It is the responsibility of customer's technical departments to evaluate the suitability of the product for the intended application and the completeness of the product information given in this document with respect to such application.

For further information on technology, delivery terms and conditions and prices, please contact the nearest Infineon Technologies Office ([www.infineon.com](http://www.infineon.com)).

#### WARNINGS

Due to technical requirements products may contain dangerous substances. For information on the types in question please contact your nearest Infineon Technologies office.

Except as otherwise explicitly approved by Infineon Technologies in a written document signed by authorized representatives of Infineon Technologies, Infineon Technologies' products may not be used in any applications where a failure of the product or any consequences of the use thereof can reasonably be expected to result in personal injury.

单击下面可查看定价，库存，交付和生命周期等信息

[>>Infineon\(英飞凌\)](#)