

# Infineon 1400 W DC-DC ZVS Full-bridge solution for server and industrial SMPS systems

EVAL\_1K4W\_ZVS\_FB\_CFD7

Di Domenico Francesco (IFAT PMM ACDC AE GTMS)  
Zechner Florian (IFAT PMM ACDC AE)

Downloaded From [Oneyac.com](https://www.oneyac.com)



# Table of contents

1

General description

2

Test results

3

Design concept

# Table of contents

1

General description

2

Test results

3

Design concept

# Evaluation board with 600 V CoolMOS™ CFD7 superjunction MOSFET



EVAL\_1K4W\_ZVS\_FB\_CFD7

Technical & order details

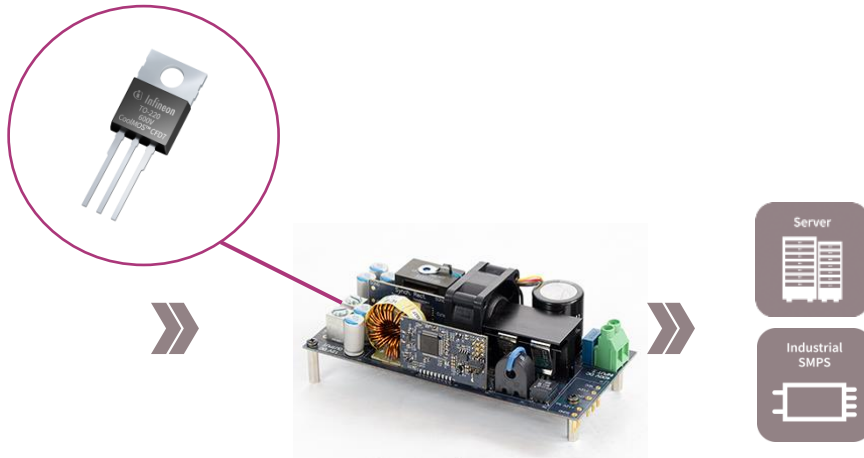

Parameter	Value
Input voltage	350 V <sub>DC</sub> ~ 410 V <sub>DC</sub>
Output voltage	11.8 V <sub>DC</sub> ~ 12.2 V <sub>DC</sub>
Max output current	117 A
Output Power	1400 W
Peak Efficiency @50% load	>96.5%

Learn more	
Sales name	EVAL_1K4W ZVS FB CFD7
SAP Mat number	SP001783674
Infineon Order Code	EVAL1K4WZVSFBCFD7TOBO1

## Features

- › Full digital control, with both peak current mode and voltage mode options implemented
- › Fast body diode device for high reliability even in critical operations
- › Innovative stacked planar transformer concept
- › Graphical User Interface (GUI)

## Benefits

- › High Efficiency in the whole load range
- › High Power density
- › Safe operation in all conditions
- › Easy interaction and fine tuning with GUI

Following additional expert kits are available

- › KIT\_6W\_12V\_BIAS\_ICE3 DC-DC Bias board
- › KIT\_6W\_12V\_BIAS\_ICE5 DC-DC Bias board

# General

This is a high-performance evaluation board example with a complete Infineon solution, including high voltage and low voltage power MOSFETs, controllers and drivers. This board demonstrates a very effective way to design the high voltage DC-DC stage of a server or industrial SMPS fulfilling the highest standard of efficiency and reliability. The overall best-in-class performance is achieved because of a mix of proper control techniques and best-in-class power device selection. Key Infineon products used to achieve this performance level include, [600V CoolMOS™ CFD7](#) SJ MOSFET ([IPP60R170CFD7](#)), EiceDRIVER™ [2EDN](#) advanced dual-channel gate driver IC ([2EDN7524F](#)), [OptiMOS™ 5 80V](#) synchronous rectification MOSFETs ([BSC026N08NS5](#)), [XMC™](#) microcontroller ([XMC4200-F64K256 BA](#)) and an auxiliary supply solution featuring off-line SMPS current mode controller IC ([ICE5QSAG](#)) with an integrated 800 V CoolMOS™ device.

## Summary of features:

- › Input voltage: 350–410 V<sub>DC</sub> (nom. 400 V<sub>DC</sub>)
- › Output voltage: 12 V±4%
- › Max. output current/power: 117 A/1400 W
- › Switching Frequency: 100 KHz

## The following variant is available:

- › EVAL\_1K4W\_ZVS\_FB\_CFD7



# 1400 W DC-DC ZVS full-bridge solution for server and industrial SMPS systems

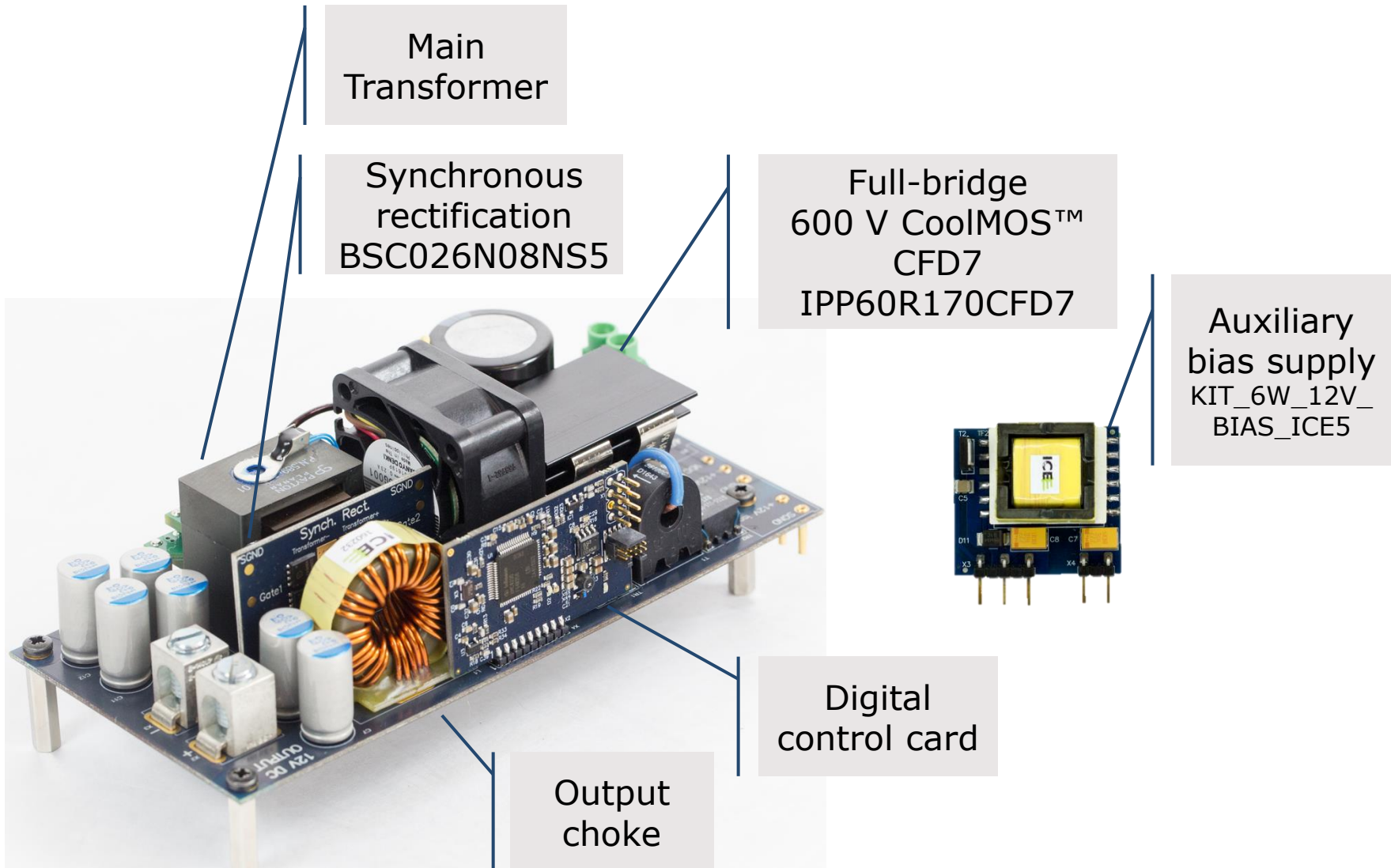

# Principle of operation I

- > The ZVS PSFB topology principle of operation is already described in [1]. For the reader's convenience, Figures 2 and 3 recap the fundamental steps.

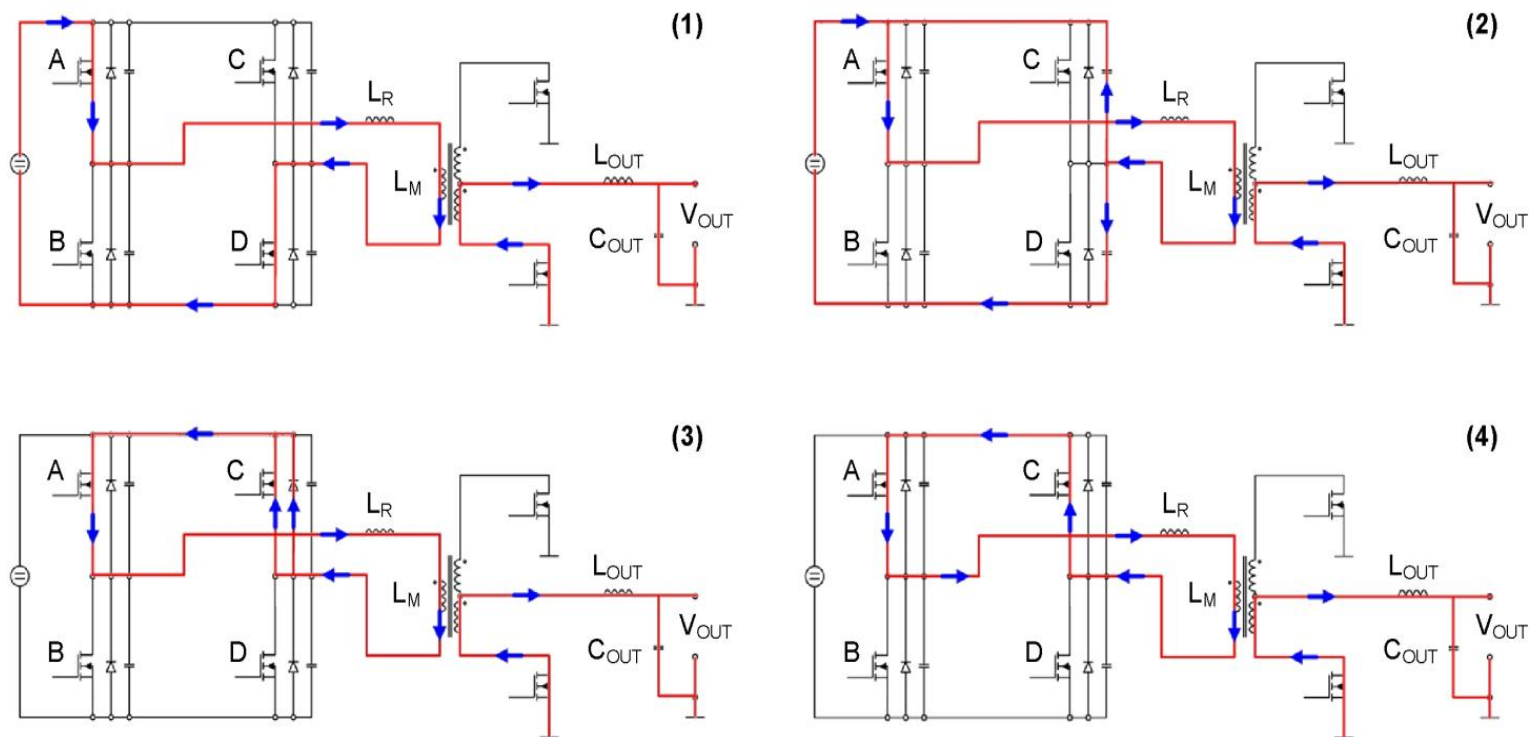

# Principle of operation II

- › Power transfer phase: MOSFETs A and D are turned on and the current flows as shown in the diagram. During this phase the primary current is rising according to the value of the total primary inductance.
- › The second phase is responsible for the zero-voltage switching of MOSFET C. In order to reach a zero-voltage turn-on, the energy stored in the resonant inductance is used to discharge the output capacitance of MOSFET C and charge the output capacitance of MOSFET D.
- › After the output capacitance of MOSFET C is discharged, the current is commutating to the body-diode of MOSFET C.
- › MOSFET C is actively turned on and the current is flowing through the channel and not through the body-diode anymore. This phase is also called the "freewheeling phase".

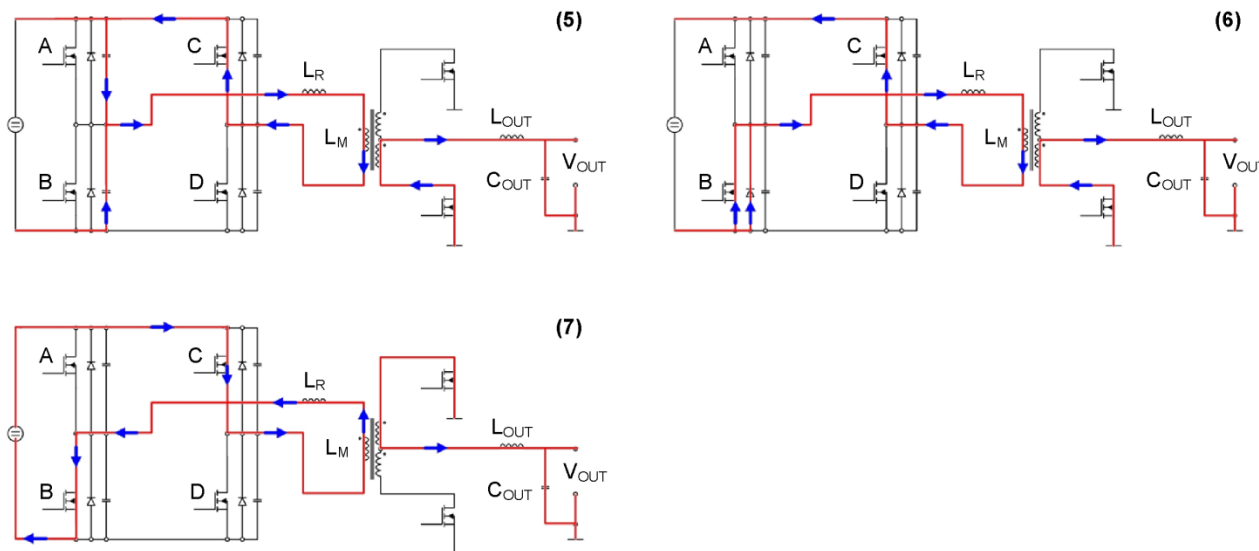



# Principle of operation III

- › In order to start a new power transfer phase MOSFET B is turned on. This phase is achieved in the same way as phase 2 by turning off MOSFET A. The output capacitance of MOSFET A is charged and the output capacitance of MOSFET B is discharged before actively switching on the MOSFET.
- › The body-diode conduction time of MOSFET B, which is visible in this phase, should also be reduced to a minimum as in phase 3.
- › MOSFET B is actively turned on, the current changes its direction and the next power transfer phase starts.
- › Figure 4 shows the control signals applied to the four MOSFETs of the bridge.
- › (1) and (7) are power transfer phases, whose duration defines the total effective on-time (and thus the duty cycle), which is given by the overlapping conducting period of the MOSFET on the same diagonal (A–D and B–C). The time intervals (2)–(3) and (5)–(6) are also called dead times: they represent the time between the turn-off and turn-on of the MOSFETs on the same leg. They must be set long enough in order to achieve the Zero Voltage Switching (ZVS) turn-on.

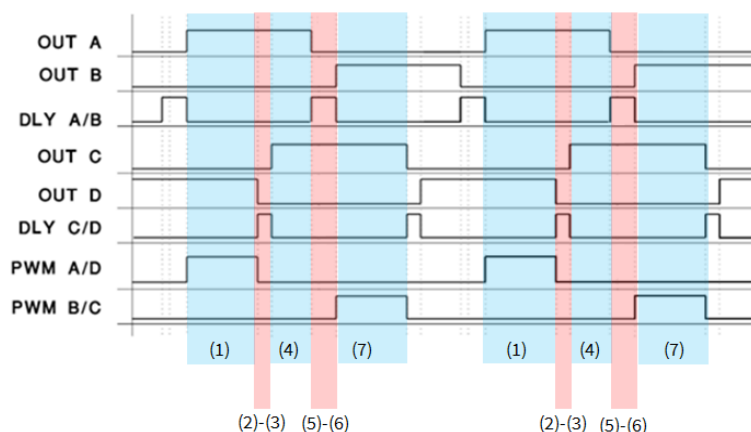

# Principle of operation IV

- › It can be observed that the duration of these two times is not equal: the one applied to the C–D leg is lower compared to the one applied to the A–B leg. This is because C–D starts a ZVS transition after a power transfer phase, so with more resonant energy available compared to A–B, which starts the transition before the power transfer.
- › For this reason C–D is commonly called the “lagging leg” and A–B the “leading leg”.
- › Thus, assuming the same MOSFETs ( $C_{oss}$ ) are used in the two legs, the time needed to discharge the output capacitance is obviously lower for the lagging leg compared to the leading leg.
- › Further and more detailed explanations of the ZVS PSFB topology operation and control, including the secondary synchronous rectification, are reported in section 4 of this document.

# Board schematics

## Main converter - Primary side

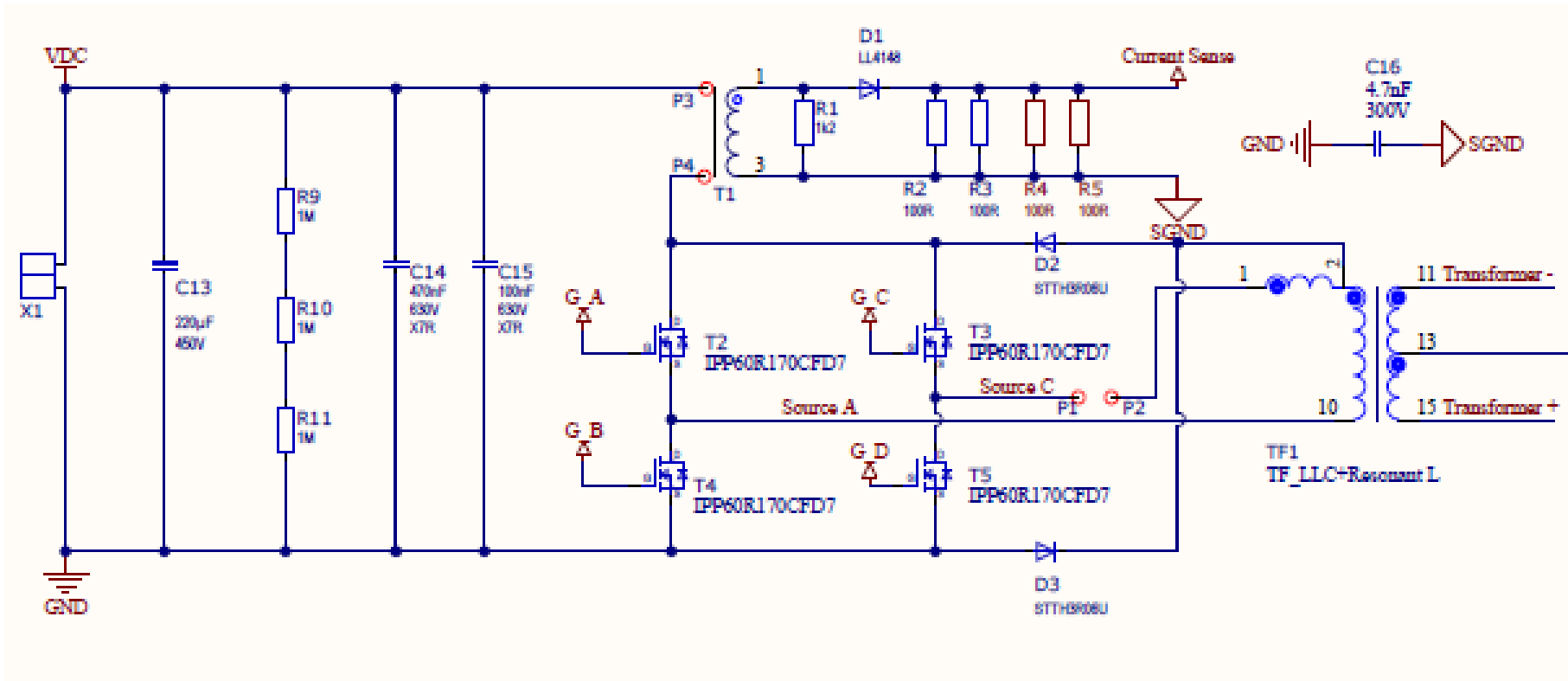

# Board schematics

## Main converter - Secondary side

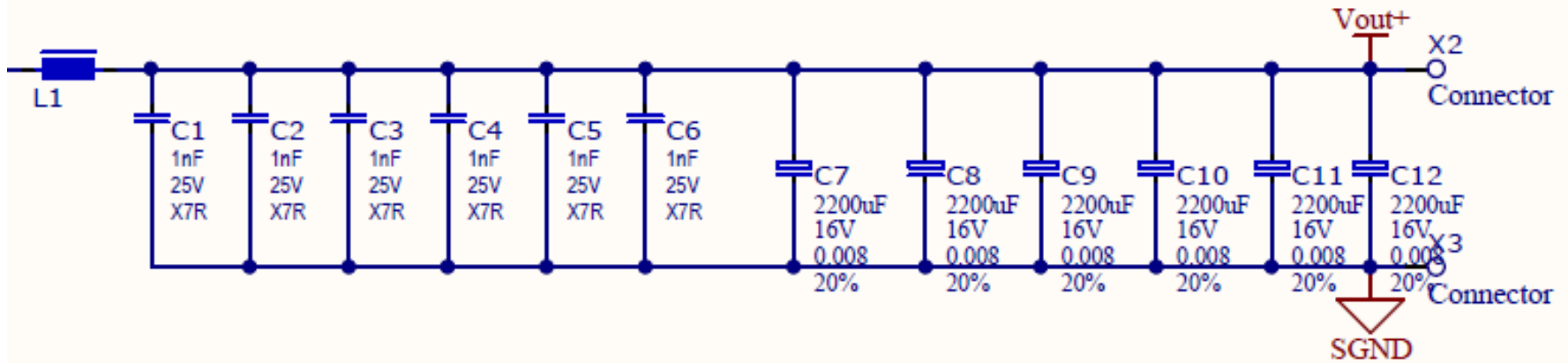

# Board schematics

## Main converter - Gate driver

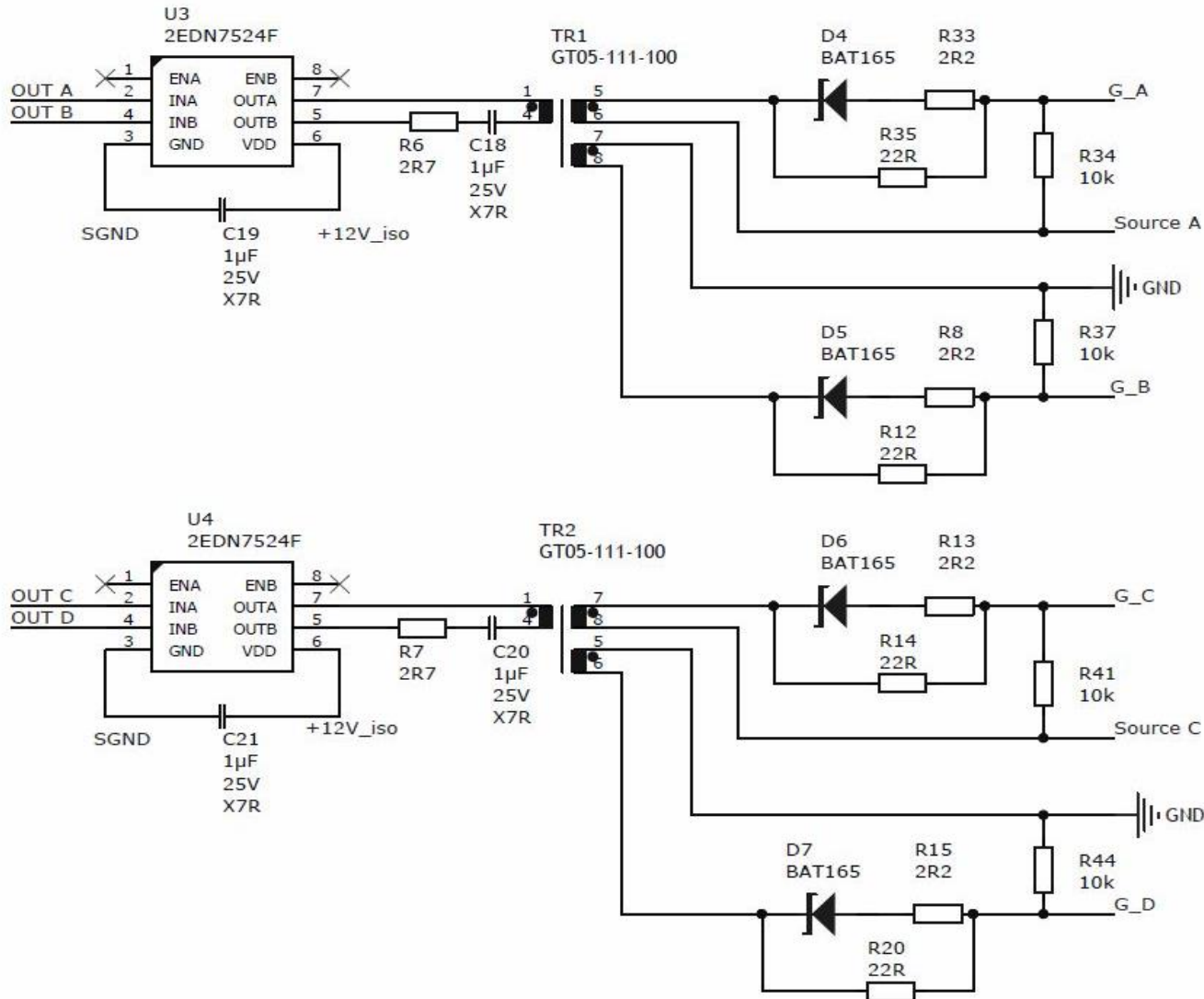



# Board schematics

## Control board - Microcontroller pin-out

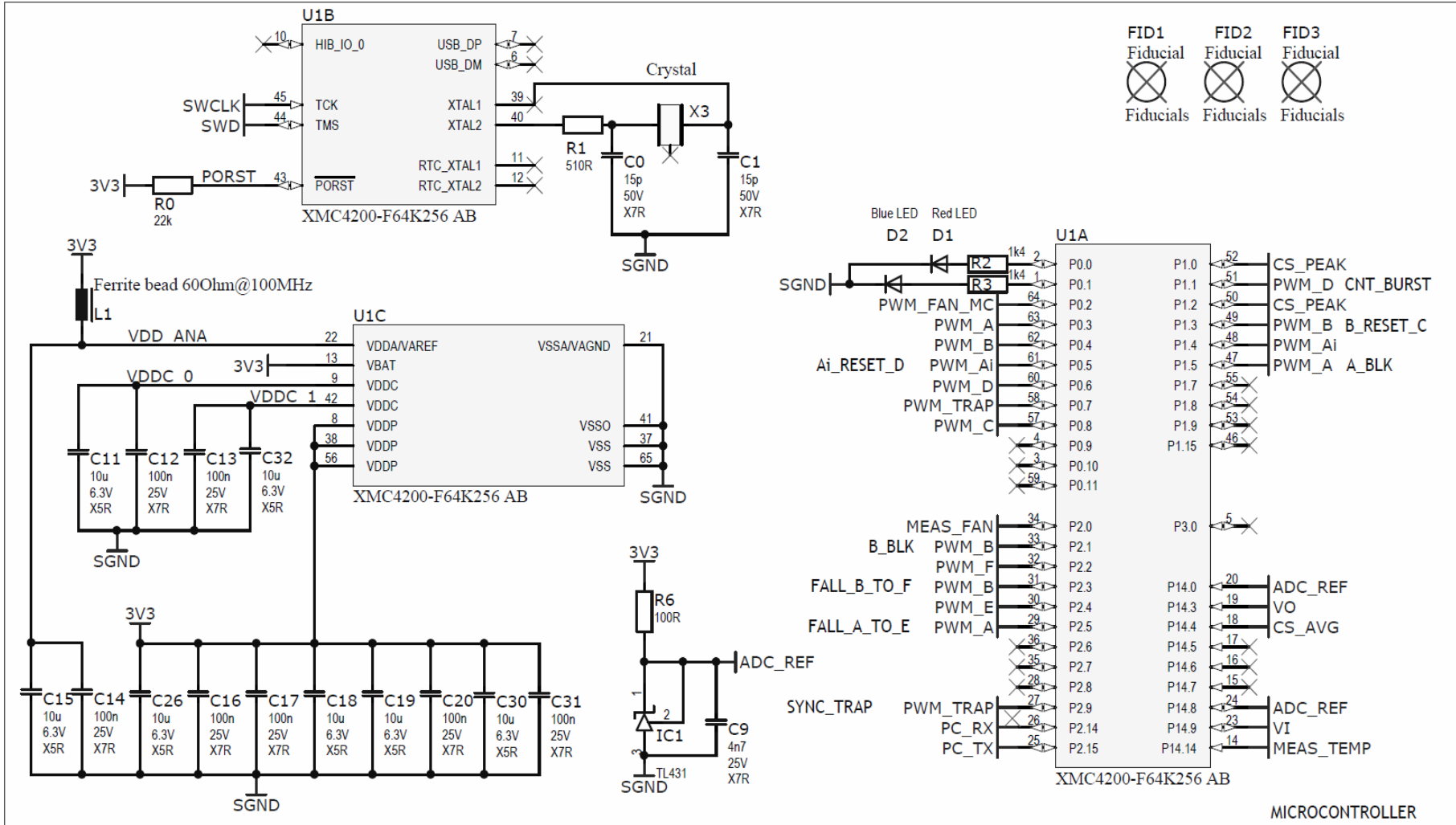

# Description

## KIT\_6W\_12V\_ICE5 (one bias board included)



**Ordering code:**  
**KIT\_6W\_12V\_ICE5**

Auxiliary supply solution featuring off-line SMPS current mode controller IC with an 800 V CoolMOS™

### Board components

- › QR flyback PWM controller 5th generation ([ICE5QSAG](#))
- › 800 V CoolMOS™ P7 SJ MOSFET ([IPU80R4K5P7](#))

### Board specifications

- › Input voltage: 90 V<sub>DC</sub> - 400 V<sub>DC</sub>
- › Output voltage: 12 V<sub>DC</sub> (prim. and sec. side)
- › Output power max.: 6 W (prim. + sec. side)

### To be used with the following boards

- › [EVAL\\_800W\\_ZVS\\_FB\\_CFD7](#)
- › [EVAL\\_1K4W\\_ZVS\\_FB\\_CFD7](#)
- › [EVAL\\_2KW\\_ZVS\\_FB\\_CFD2](#)
- › [EVAL\\_2KW\\_ZVS\\_FB\\_CFD7](#)
- › [EVAL\\_2.5KW\\_CCM\\_4PIN](#)
- › [EVAL\\_2K5W\\_CCM\\_4P](#)



# Bias board

## KIT\_6W\_12V\_ICE5 (one bias board included)

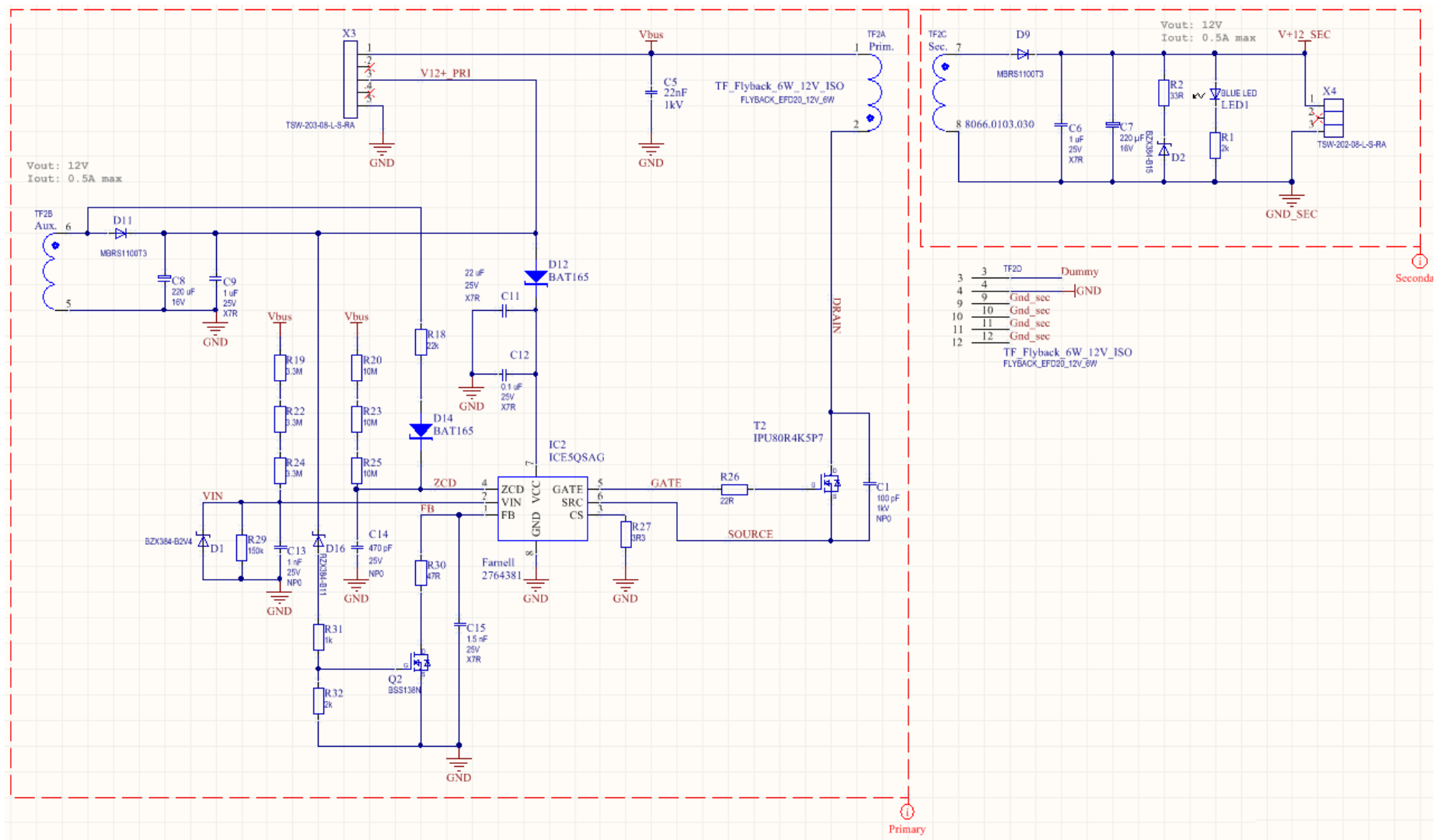

# Magnetic Main transformer

Measurement	Terminal	Specification
Magnetizing inductance	2-10	2.1 mH +/- 20% @ 100 kHz, 0.5 Vrms
Leakage inductance	2-10 (11-15 shorted)	4.3 μH nominal @ 100 kHz, 0.5 Vrms
Inductor inductance	1-2	21 μH +/- 15% @ 100 kHz, 0.5 Vrms
DCR	1-10	280 mΩ max.
	11-15	0.6 mΩ max.
TR	2-10:11-13	22
	2-10:13-15	22
Hi-pot	Pri. to sec.	4.0 kV AC, 6 mm creepage
Hi-pot	Pri. to core	2.5 kV AC
Hi-pot	Sec. to core	0.5 kV DC

Electrical specifications at 25°C ±5°C:

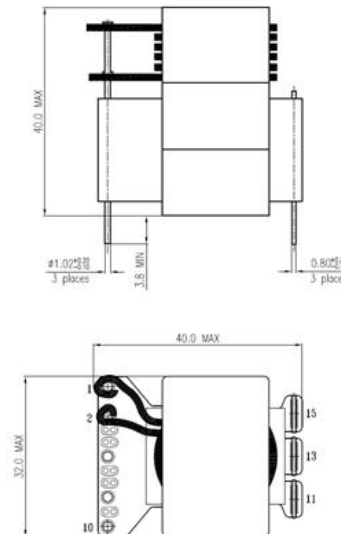

# Magnetic Bias transformer



Electrical diagram.

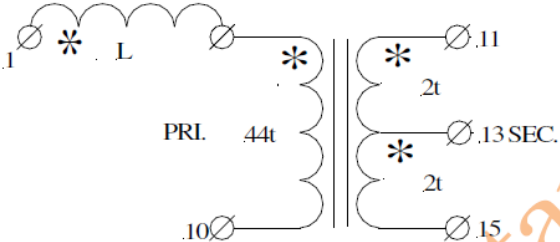

Terminals layout sketch (preliminary; top view; not to scale)

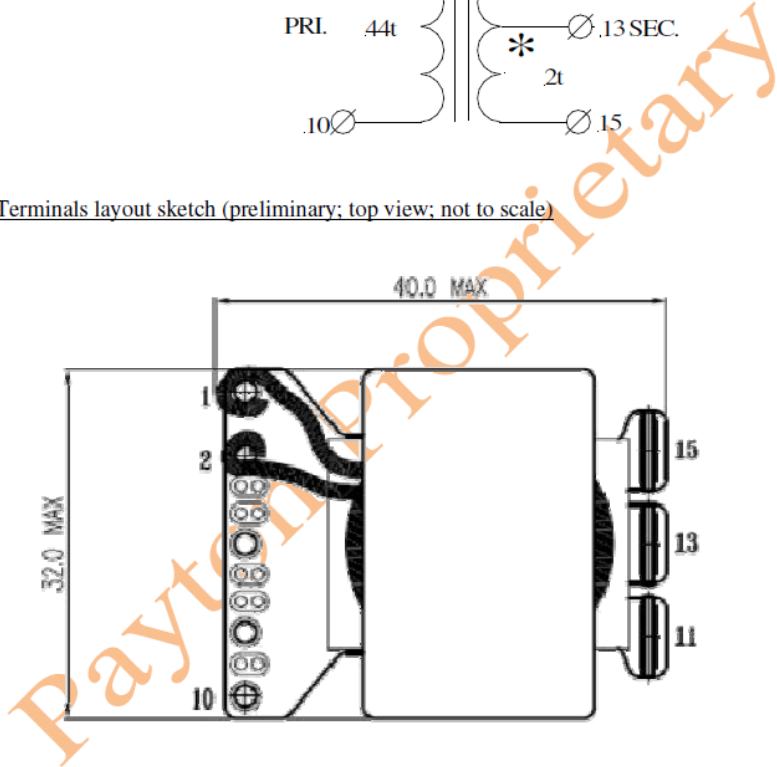

Note Terminations made of through hole pins.

# Magnetic Output choke

## 800W ZVS Phase Shift Full Bridge Output Choke Design\_ F. Di Domenico

<b>Core Part Number:</b>	Magnetics 58930-A2 or CSC CH270125 or equivalent
<b>Permeability:</b>	125
<b>Inductance Factor:</b>	157 mH/1000 Turns
<b>Core Area:</b>	0.661 sq cm
<b>Path Length:</b>	6.54 cm
<b>Turns:</b>	6
<b>Wire Size:</b>	3 strands of #12 AWG or 5 strands diam. 1.25mm
<b>DC Resistance:</b>	0.001 Ohms
<b>Header P/N:</b>	TV-H4916-4A
<b>Wound Core Dimensions:</b>	TDB
<b>Inductance (full load):</b>	2.05 $\mu$ H
<b>Inductance (no load):</b>	5.65 $\mu$ H
<b>Core Losses:</b>	811.2 mW
<b>Copper Losses:</b>	4894.0 mW
<b>Total Losses:</b>	5705.2 mW
<b>Temp. Rise:</b>	63.0 degrees C



# Table of contents

1

General description

2

Test results

3

Design concept

# Efficiency plots

- > The efficiency plots reported here are measured with a fully automated set-up and following the typical procedures prescribed by the 80+ standard.

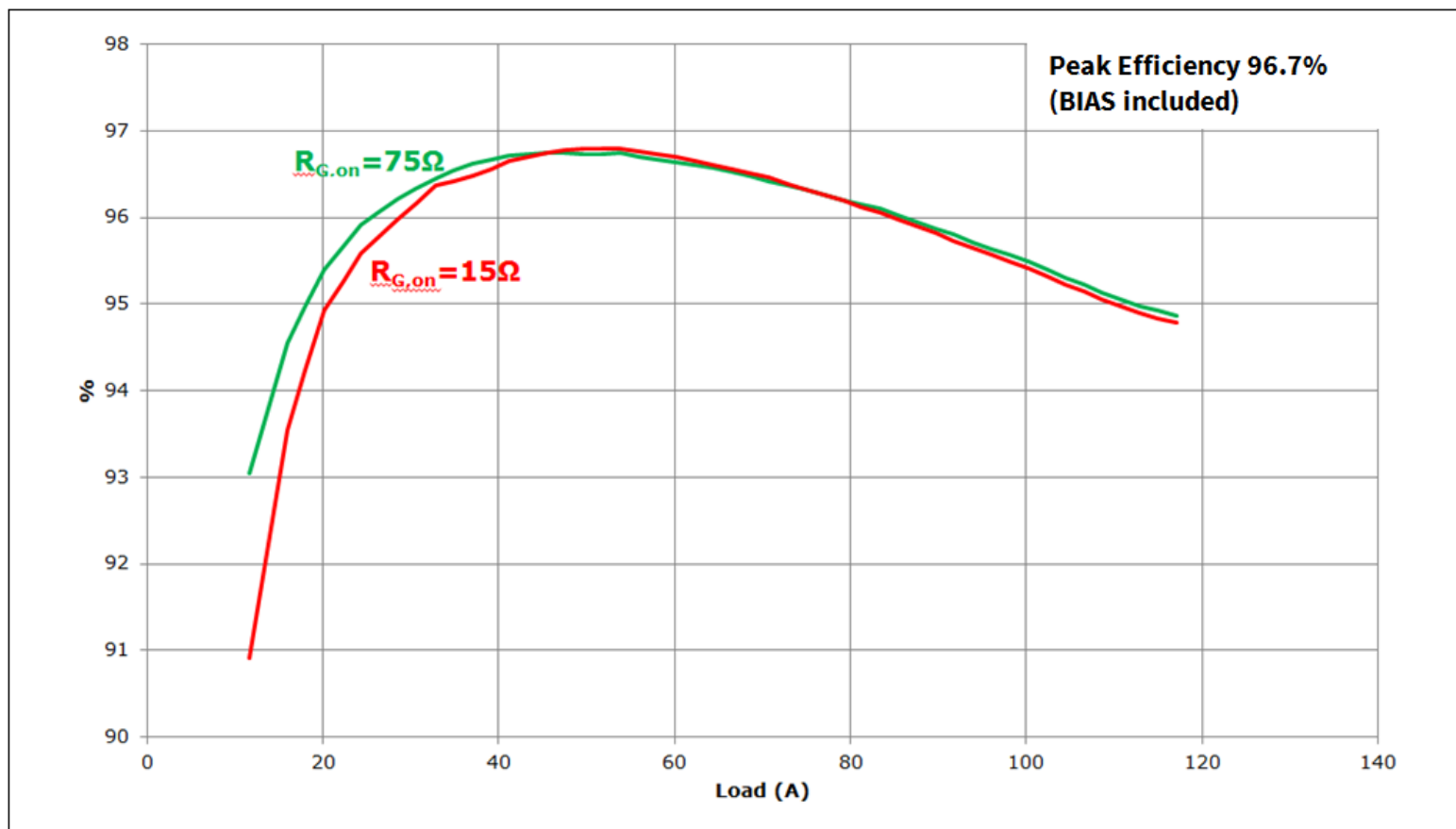

Effect of different vales of  $R_{G,on}$  on IPP60R170CFD7 efficiency plot in 1400W demo board

# Table of contents

1

General description

2

Test results

3

Design concept

# Design concept

This general description provides an overview of the Infineon 1400 W ZVS PSFB demo board based on the new CoolMOS™ CFD7 technology, for extended information please refer to the related application note.

- › The design concept and the performance evaluation are described in the Application Note with special focus on the key contribution of the CFD7 technology to enable high efficiency combined with reliable operation across the whole load range, including the typical critical modes of this topology. In fact the demo board design is optimized for the 170 mΩ 600 V CoolMOS™ CFD7 JS MOSFET device, namely IPP60R170CFD7.
- › An important contribution to the final excellent results also comes out of the applied digital control by Infineon XMC4200. Two possible options, peak current mode and voltage mode, are offered to users for the converter control: these two are in fact the most popular in SMPS application of the PSFB topology. The applied control paths, on both the primary and secondary MOSFETs, with optimized delay time setting, enable an efficiency plot targeting the HV DC-DC stage of a 80+ Platinum level server power supply. A GUI has been designed to help the user interact with the demo board: it enables real-time reading of some key electrical parameters, along with the possibility of designing fine-tuning and protection monitoring.
- › The planar main transformer with stacked resonant choke helps achieve the high power density of the demo board and minimizes AC and core losses, resulting in high efficiency across the entire load range, along with a perfect heat spread.
- › The final result is a robust and high-performance design able to fulfill all the general requirements for the HV DC-DC isolated stage of a server or industrial SMPS.



# Design concept

- › This paper demonstrates that the ZVS PSFB topology is a valuable alternative to the LLC topology in addressing the 80+ Platinum standard. A proper power devices selection, both in the primary and secondary side, and an appropriate control enable a good balance of performance, cost and reliability, avoiding all the pitfalls of a fully resonant approach, as in the LLC topology.
- › Further developments of the present design are already planned at Infineon:
  - › The gate-driving concept used for the HV MOSFETs on the primary side is going to be improved thanks to the upcoming Infineon 2EDS family of driver ICs with reinforced isolation: this will enable replacement of the gate drive transformers and will provide a reliable and efficient solution with even smaller form factor.



## Technical Material

- > Application Notes
- > Simulation Models
- > Datasheets
- > PCB Design Data

- > [EVAL\\_1K4W\\_ZVS\\_FB\\_CFD7](#)
- > [EVAL\\_800W\\_ZVS\\_FB\\_CFD7](#)
- > [EVAL\\_2KW\\_ZVS\\_FB\\_CFD2](#)
- > [EVAL\\_2KW\\_ZVS\\_FB\\_CFD7](#)
- > [EVAL\\_2K5W\\_CCM\\_4P](#)

## Evaluation Boards

- > Evaluation Boards
- > Demoboards
- > Reference Designs

- > [www.infineon.com/evaluationboards](http://www.infineon.com/evaluationboards)

## Videos

- > Technical Videos
- > Product Information Videos

- > [www.infineon.com/mediacenter](http://www.infineon.com/mediacenter)

# Support

## Online tools and services



The screenshot shows the Infineon website header with the following elements:

- Infineon logo
- Navigation menu: Products, Applications, **Tools** (highlighted with a red box and number 3), About Infineon, Careers
- Utility links: **Newsletter** (highlighted with a red box and number 1), Contact, **Where to Buy** (highlighted with a red box and number 2), English, Login
- Search bar with a magnifying glass icon

The main content area features a large image of a city skyline at night. Overlaid on the right side of the image is a teal box with the following text:

### Lighting

New LED controller enables low-wattage luminaire designs  
August 26th 17:00 CEST

[Register Now!](#)

- 1 **Subscribe to Newsletter**
- 2 **Where to Buy**
- 3 **Tools, Finders and Selectors**
- 4 **Support**

- **Products**
  - Applications
  - **Tools**
  - **Support** (highlighted with a red box and number 4)
  - Technology
- **Power**
  - Automotive System IC
  - ESD & EMI
  - Microcontroller
  - RF & Wireless Control
  - Security IC
  - Sensor
  - Smart Card IC
  - Interface
  - Transistor & Diode
- **Power Overview**
  - Power MOSFET
  - IGBT
  - Smart Low-Side & High-Side Switches
  - Linear Voltage Regulator
  - DC-DC Converter
  - LED Driver | Lighting ICs
  - Silicon Carbide (SiC)
  - High Power Thyristors & Diodes
  - Motor Control & Gate Driver
  - AC-DC Supply

News & Tweets



Part of your life. Part of tomorrow.



单击下面可查看定价，库存，交付和生命周期等信息

[>>Infineon\(英飞凌\)](#)