

EVAL-M1-2ED2106S User Manual

2ED2106S06F Evaluation board for BLDC motor drives

About this document

Scope and purpose

This application note provides an overview of the evaluation board EVAL-M1-2ED2106S concerning its main features, hardware description, thermal performance and typical waveforms, etc.

The EVAL-M1-2ED2106S board is a power drive board including driver ICs, IGBTs, a power connector and signal interface. The board is intended to drive a brushless direct current (BLDC) motor by connecting to an external controller board such as EVAL-M1-101T.

The board aims to boost Infineon's newly promoted 650 V high and low side gate driver [2ED2106S06F](#) using the silicon-on-isolator (SOI) technology.

Intended audience

This application note is intended for all technical specialists likely to evaluate the 650 V SOI gate drivers for general applications.

Table of contents







About this document	1
Table of contents	1
1 Safety precautions	2
2 Introduction	3
3 Main features of EVAL-M1-2ED2106S	4
3.1 Board specifications of EVAL-M1-2ED2106S.....	4
3.2 Pin assignment.....	6
4 Key components in the EVAL-M1-2ED2106S	8
4.1 650 V SOI gate driver	8
4.2 TrenchStop™ IGBT6 IKB10N65ET6	9
5 Test result of the EVAL-M1-2ED2106S driving BLDC motor	10
5.1 System setup	10
5.2 Waveforms.....	11
6 Thermal analysis of the EVAL-M1-2ED2106S	13
7 Circuit diagram of the EVAL-M1-2ED2106S	14
7.1 Schematic overview	14
7.2 Main power circuit.....	15
7.3 OCP circuit	15
7.4 Auxiliary power supply circuit.....	18
8 PCB layout of the EVAL-M1-2ED2106S	19
9 Bill of material	24
10 Reference	27
Revision history	28

Safety precautions

1 Safety precautions

Please read carefully the following statements in Table 1 regarding hazards associated with the evaluation board and the testing system, and the safety precautions listed in the manual.

Table 1 Safety precautions

	Caution: <i>The ground potential of the EVAL-M1-2ED2106S board is biased to a negative DC bus voltage potential. When measuring voltage waveform by oscilloscope, the ground of the device needs to be isolated. Failure to do so may result in personal injury or death, and equipment damage.</i>
	Caution: <i>Only personnel familiar with the drive and associated machinery should plan or implement the installation, start-up and subsequent maintenance of the system. Failure to comply may result in personal injury and/or equipment damage.</i>
	Caution: <i>The surfaces of the drive may become hot, which may cause injury.</i>
	Caution: <i>The EVAL-M1-2ED2106S board contains parts and assemblies sensitive to electrostatic discharge (ESD). Electrostatic control precautions are required when installing, testing, servicing or repairing this assembly. Component damage may result if ESD control procedures are not followed. If you are not familiar with electrostatic control procedures, refer to applicable ESD protection handbooks and guidelines.</i>
	Caution: <i>An incorrectly applied or installed drive can result in component damage or reduction in product lifetime. Wiring or application errors such as undersized motor, incorrect or inadequate DC supply, or excessive ambient temperatures may result in system malfunction.</i>
	Caution: <i>Remove or connect the control board from, or to, the power drive. Wait three minutes after removing power from the power drive to discharge the bus capacitors. Do not attempt to service the drive until the bus capacitors have discharged to zero. Failure to do so may result in personal injury or death.</i>

Introduction

2 Introduction

Note: Evaluation boards are not subject to the same procedures as regular products regarding Returned Material Analysis (RMA), Process Change Notification (PCN) and Product Discontinuation (PD). Evaluation boards are intended to be used under laboratory conditions and by trained specialists only.

The power stage of the evaluation board EVAL-M1-2ED2106S consists of a three-phase inverter with a single-shunt configuration, which is widely used for the BLDC motor drive in home appliances.

The 650 V SOI gate driver 2ED2106S06F is highlighted in the board. Different from traditional drivers with junction isolated (JI) technology, the SOI gate driver shows the benefits of a simpler design by integrating the boot strap diode, and there is higher tolerance of the negative V_s due to the SOI technology inherently.

The IGBTs with Infineon TrenchStop™ IGBT6 technology have been adopted in the board. Thanks to the high performance of the IGBT6 with the optimized conduction loss and switching loss, under natural cooling the board can run up to 300 W, which is common for refrigerator products.

The board is intended to work together with the controller board EVAL-M1-101T to deliver a total Infineon solution with low cost and high robustness for the home appliance applications.

The board is available via regular Infineon distribution partners as well as on Infineon's website. The features of this board are described in Chapter 3 of this document. The remaining sections provide information to enable customers to copy, modify and qualify the design for production according to their own specific requirements.

Environmental conditions were considered in the design of the EVAL-M1-2ED2106S. However, the board has not been qualified in terms of safety requirements, manufacturing and operation over the entire operating temperature range or lifetime. The boards provided by Infineon are subject to functional testing only.

Figure 1 depicts the block diagram of the EVAL-M1-2ED2106S.

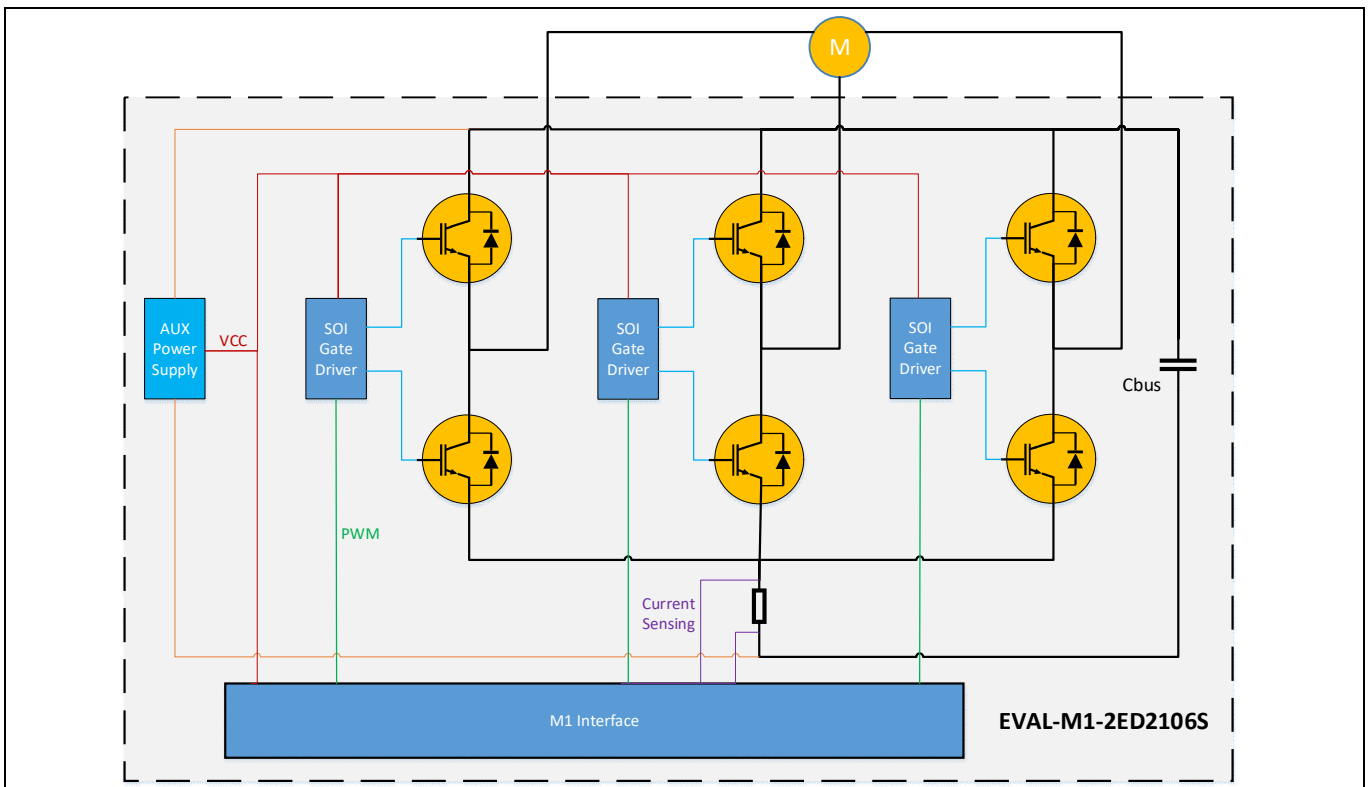

Figure 1 Block diagram of the EVAL-M1-2ED2106S

Main features of EVAL-M1-2ED2106S

3 Main features of EVAL-M1-2ED2106S

The main features of the evaluation board EVAL-M1-2ED2106S include:

- Three-phase inverter with single-shunt configuration, suitable for home appliance applications
- DC voltage input that can come directly from the rectified DC voltage of single-phase 230 V_{AC} input
- 650 V SOI gate driver 2ED2106S06F with large negative V_s tolerance
- 10 A/650 V rated IGBT6 IKB10N65ET6 with a better thermal performance
- The board can run a BLDC motor by connecting to an external control board EVAL-M1-101T
- Auxiliary power supply is included in the board
- Natural cooling with a heatsink is installed on bottom side

3.1 Board specifications of EVAL-M1-2ED2106S

The detailed specifications of the EVAL-M1-2ED2106S are described in Table 2.

Table 2 EVAL-M1-2ED2106S board specifications

Parameters	Typical	maximum	Conditions / comments
Input			
Voltage (V _{DC})	310	380	DC+ to GND
Current (A _{RMS})	0.97		310 V _{DC} input, 300 W input power
Output			
Phase current (A _{RMS})	1.6		310 V _{DC} input, 300 W input power
Switching frequency			
Inverter frequency (kHz)	15		
Current feedback			
Current sampling shunt	100 mΩ		single-shunt configuration
Aux power supply			
Supply voltage (V _{CC})	15		on-board aux power supply
System environment			
Ambient temperature	0~50 °C		natural ventilation, maximum RH of 95 %
PCB characteristics			
Dimensions	Length*Width=126x84 mm ² , 2 layers, PCB thickness=1.6 mm, copper thickness=1 oZ		
Material	FR-4, RoHS-compliant		

The top and bottom view of the EVAL-M1-2ED2106S are shown in Figure 2 and Figure 3, respectively.

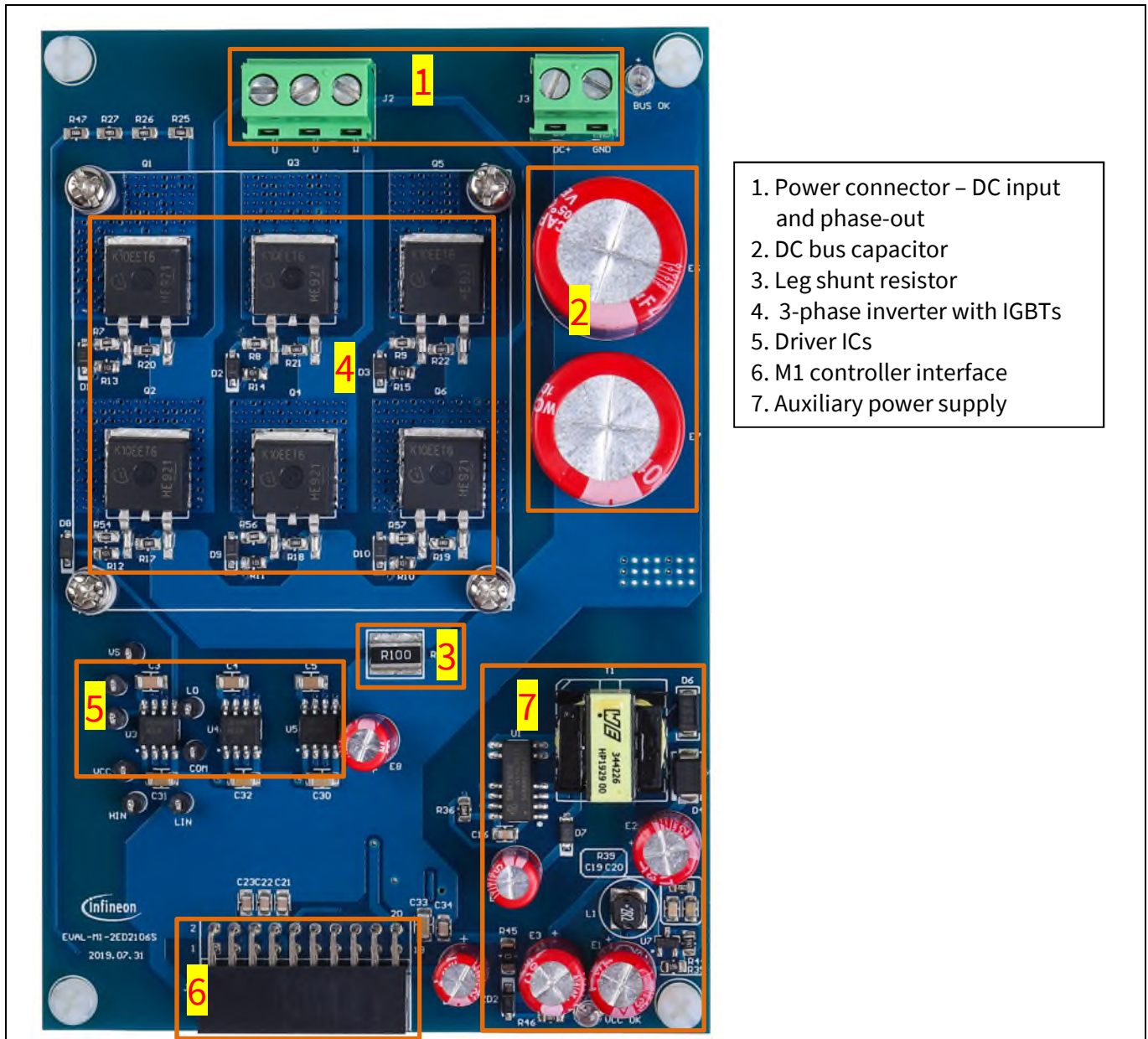

1. Power connector – DC input and phase-out
2. DC bus capacitor
3. Leg shunt resistor
4. 3-phase inverter with IGBTs
5. Driver ICs
6. M1 controller interface
7. Auxiliary power supply

Figure 2 Top view of the EVAL-M1-2ED2106S

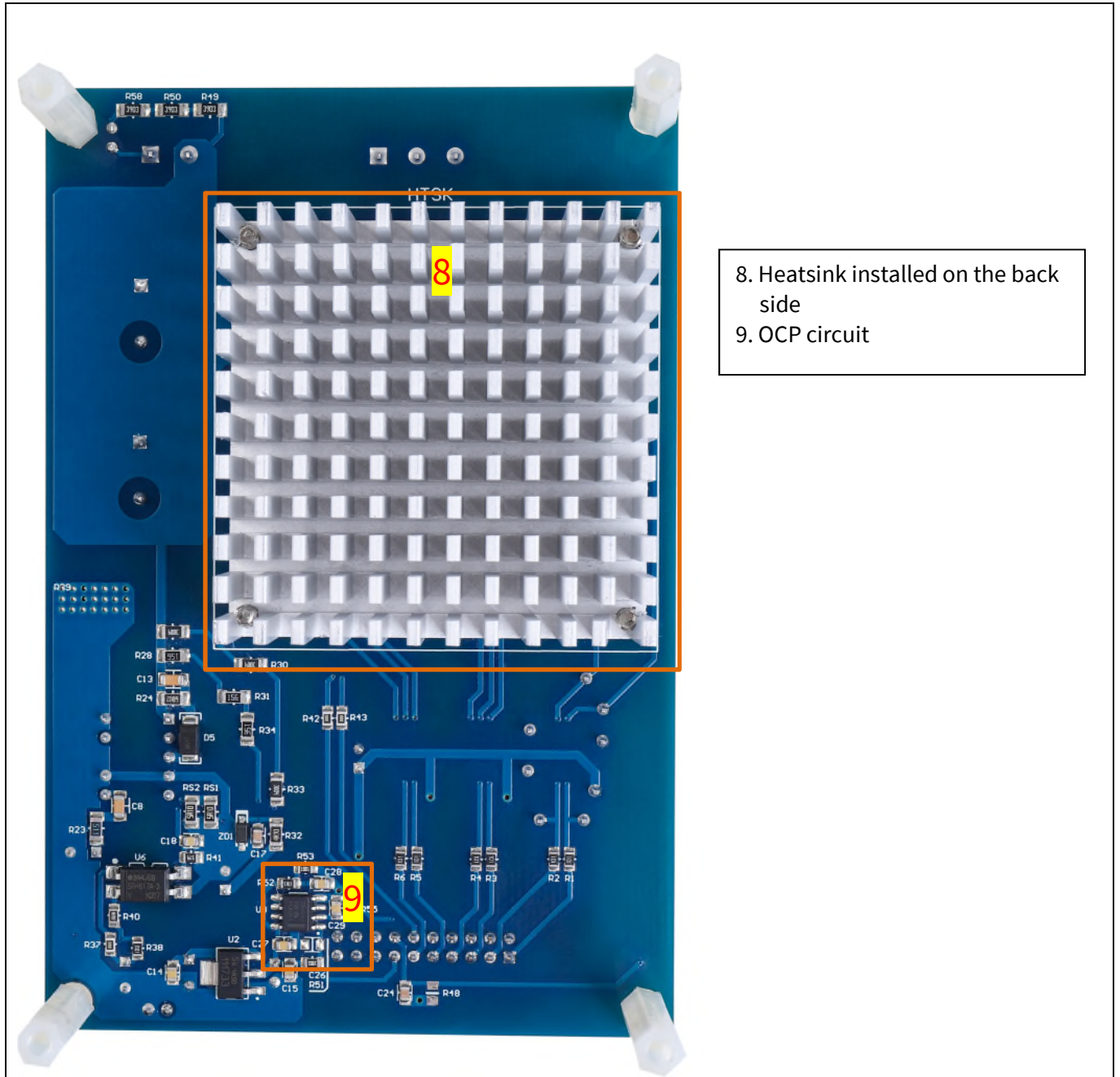

8. Heatsink installed on the back side
 9. OCP circuit

Figure 3 Bottom view of the EVAL-M1-2ED2106S

3.2 Pin assignment

The pin assignment of the phase-out connector and DC input connector are listed in Table 3 and Table 4, respectively. The pin names are also marked on the PCB.

Table 3 J2 – Phase-out connector

S. No.	Pin name	Details
	U	U – Phase-out wiring terminal
	V	V – Phase-out wiring terminal
	W	W – Phase-out wiring terminal

Main features of EVAL-M1-2ED2106S

Table 4 J3 – DC input connector

S. No.	Pin name	Details
	DC+	DC bus positive input
	GND	DC bus return

The controller interface is M1 that pin-to-pin matches with the EVAL-M1-101T. The pin assignment is listed in Table 5.

Table 5 CN2 – Controller interface

S. No.	Pin name	Details
1	UH	U-phase high side PWM input
2	GND	signal reference ground
3	UL	U-phase low side PWM input
4	GND	signal reference ground
5	VH	V-phase high side PWM input
6	+3.3 V	+3.3 V power supply
7	VL	V-phase low side PWM input
8	+3.3 V	+3.3 V power supply
9	WH	W-phase high side PWM input
10	I_U+	positive of the single-shunt current sensing
11	WL	W-phase low side PWM input
12	I_U-	negative of the single-shunt current sensing
13	GK	Gate kill signal output
14	DCB	DC bus voltage sensing output
15	NC	Not connected
16	NC	
17	NC	
18	NC	
19	NC	
20	VCC	VCC (+15 V) to the controller board

Key components in the EVAL-M1-2ED2106S

4 Key components in the EVAL-M1-2ED2106S

4.1 650 V SOI gate driver

The 2ED2106S06F is a newly developed high and low-side gate driver using SOI technology, which has many advantages compared with the commonly used JI parts:

- 650 V offset voltage and +290/-700 mA drive current are suited for general motor driving applications with universal AC input voltage
- Unique Infineon thin-film, SOI technology
- Integrated ultra-fast, low-resistance bootstrap diode
- Logic is operational up to -11 V on VS pin
- Tolerant to negative transient voltage up to -100 V provided by SOI technology
- Negative voltage tolerance on inputs of -5 V
- dV/dt immune ± 50 V
- Maximum supply voltage of 25 V
- Undervoltage lockout for both channels
- 3.3 V, 5 V, 15 V input logic-compatible
- Pin-pin replacement of the JI parts IR2106S/IRS2106S
- -40~125 °C operating range
- RoHS-compliant

The features of 2ED2106S06F and the pin-pin replaced JI parts – IR2106S/IRS2106S are compared in Table 6.

Table 6 Features' comparison of the 2ED2106S06F, IR2106S and IRS2106S

Part	2ED2106S06F	IR2106S	IRS2106S
Input logic	HIN, LIN	HIN, LIN	HIN, LIN
Max. V_B (V)	675	625	625
Min. V_{IN} (V)	-5	-0.3	-0.3
V_{CC} UVLO (V), typical	9.1/8.2	8.9/8.2	8.9/8.2
V_{BS} UVLO (V), typical	8.2/7.2	8.9/8.2	8.9/8.2
t_{ON}/t_{OFF} (nS), typical	200/200	220/200	220/200
Min. V_S (V) for logic operation	-11	-5	-5
Min. V_S (V) for transient operation	-100 V	NA	NA
Dead time (nS)	No		
Max. delay matching time MT (nS)	35	30	30
I_{O+}/I_{O-} (mA)	290/700	200/350	290/600
Integrated boot diode	Yes	No	No

4.2 TrenchStop™ IGBT6 IKB10N65ET6

- N-channel
- $V_{CE}=650\text{ V}$, $I_C=16\text{ A @ }100\text{ °C}$
- D²PAK package
- Low $V_{CE(sat)} = 1.5\text{ V @ }8.5\text{ A}$
- Optimized the gate charge Q_g for smaller switching loss
- 3 uS short-circuit capability
- Max 175 °C junction temperature
- RoHS-compliant and halogen-free

5 Test result of the EVAL-M1-2ED2106S driving BLDC motor

5.1 System setup

The board can run a BLDC motor by connecting to an external controller board. The system setup is shown in Figure 4. The following notes should be taken into consideration:

- The input voltage should be from a DC source or rectified DC voltage from a 230 V_{AC} source. In the test herein, a 310 V_{DC} / 1.5 A DC source is used.

Note: there should be a protection circuit containing the NTC and fuse to limit the inrush current during the power ON.

- A high voltage BLDC motor could run with up to 300 W load. A GK6040-6AC31-WE motor is used here for test purposes only.
- The VB, HO and VS should be measured by high-voltage, isolated differential probes, whereas the HIN, LIN, VCC and LO should be measured by low-voltage differential probes.

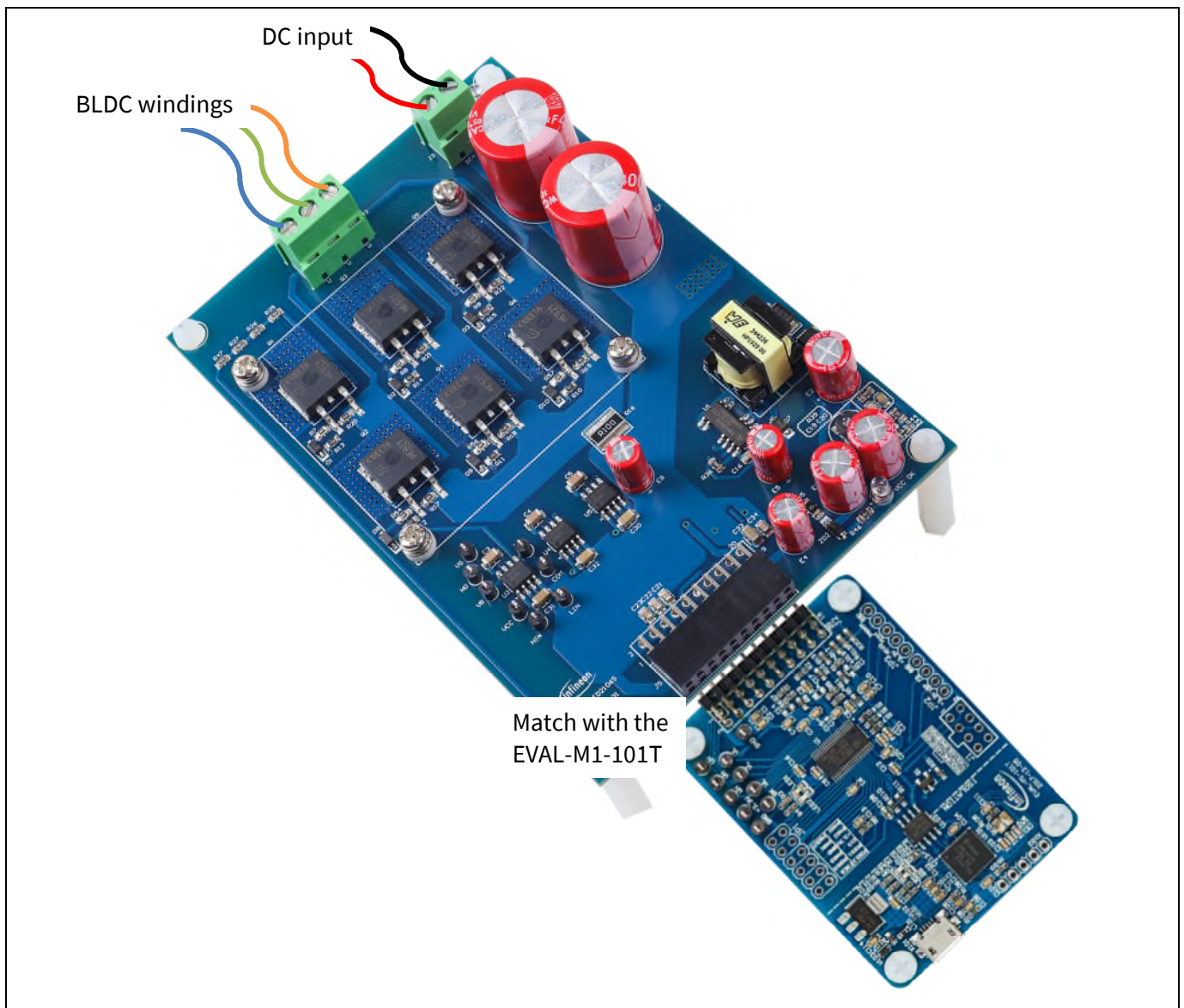

Figure 4 Test setup for running a BLDC motor

5.2 Waveforms

Before running the motor, please double check:

- Correct wiring before powering on the DC+ and GND
- The correct selection and scaling of probes
- The LED named ‘BUS OK’ lights up to indicate a successful DC bus power-up
- The LED named ‘VCC OK’ lights up to indicate a successful +15 V auxiliary power supply

When running the system at 310 V_{DC} input voltage and up to 300 W input power, the typical waveforms are depicted in Figure 5 and Figure 6.

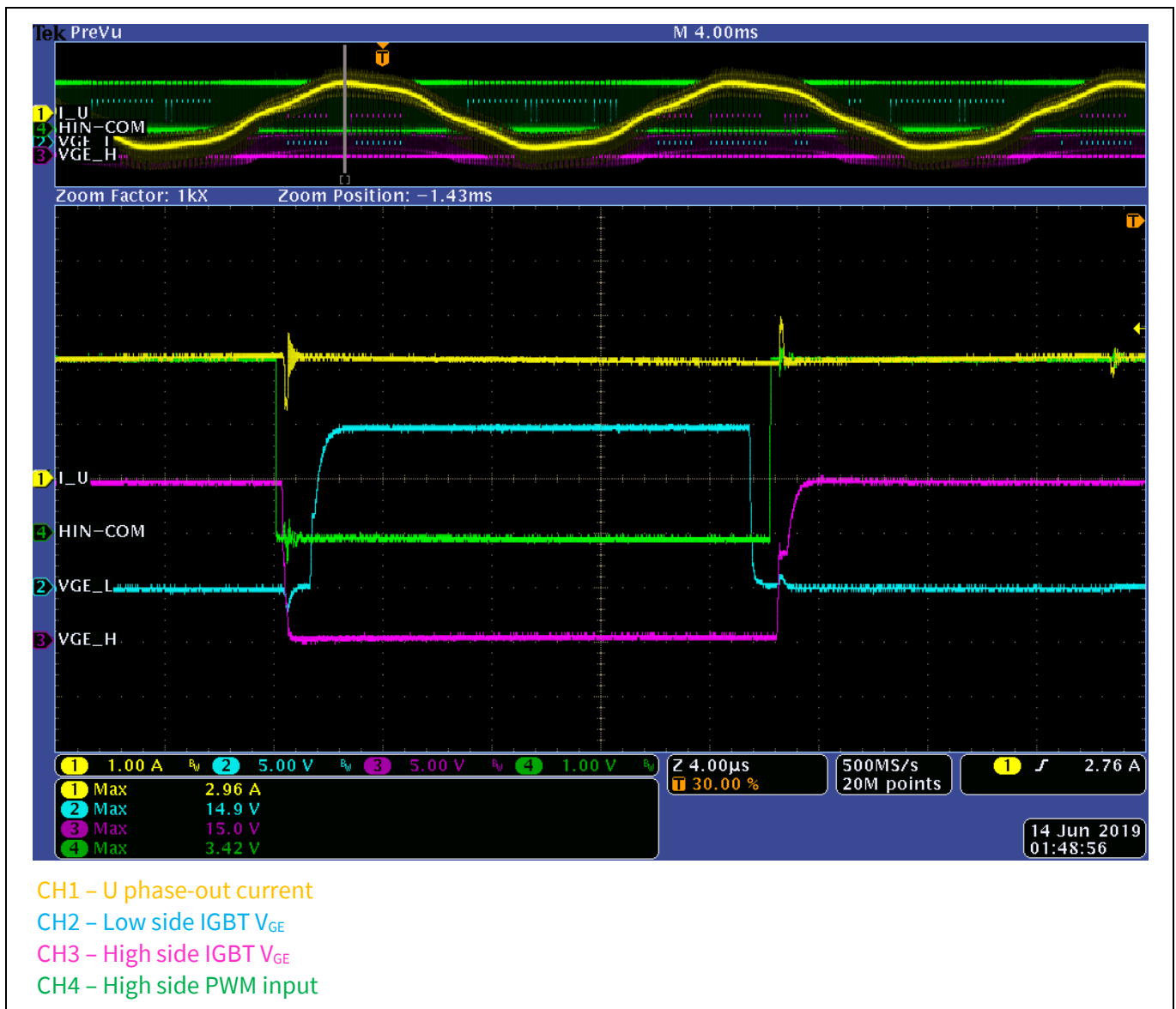

Figure 5 Test result – PWM input and gate drive output

Test result of the EVAL-M1-2ED2106S driving BLDC motor

From Figure 6, the minimum VS-COM probed at the driver IC pin is -14 V during normal operation. Owing to the much larger tolerance of the transient negative V_s (-100 V), the SOI gate driver 2ED2106S06F can work under less favorable conditions.

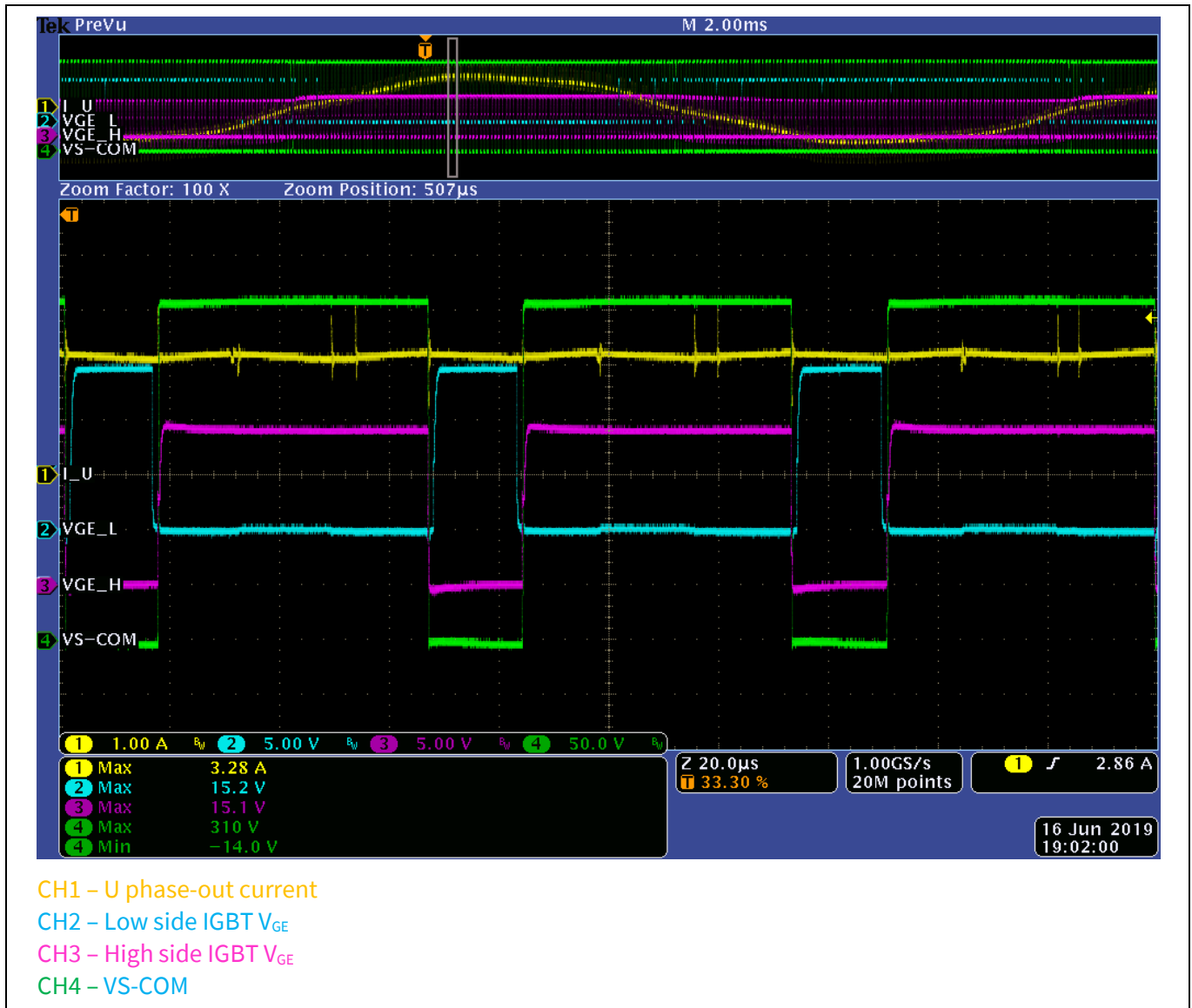

Figure 6 Test result - negative V_s

6 Thermal analysis of the EVAL-M1-2ED2106S

The thermal performance is evaluated at 310 V_{DC} input voltage and 300 W input power with 15 kHz switching frequency at 26.2 °C ambient temperature. The thermal data are recorded in Figure 7.

The key component temperatures are all in the normal range:

- IGBT: The maximum case temperature is 86 °C. The junction temperature is less than 100 °C calculated by the Infineon IPOSIM online simulation tool.
- Shunt resistor: The shunt resistor is rated 3 W @ 70 °C in the operating temperature range of -55~155 °C. The maximum shunt temperature is 63.8 °C with a large margin.
- Gate driver IC: The maximum junction temperature of the 2ED2106S06F is 150 °C. The case temperature is 50.1 °C. The gate driver IC power loss consists of two major parts, the internal level-shift switching loss and the driving loss. For driving the IKB10N65ET6 under 15 kHz switching frequency, the calculated total power loss of the gate driver is around 0.06 W, thus the junction temperature is estimated at $50.1\text{ °C} + 0.06\text{ W} \cdot 60\text{ °C/W} = 53.7\text{ °C}$.

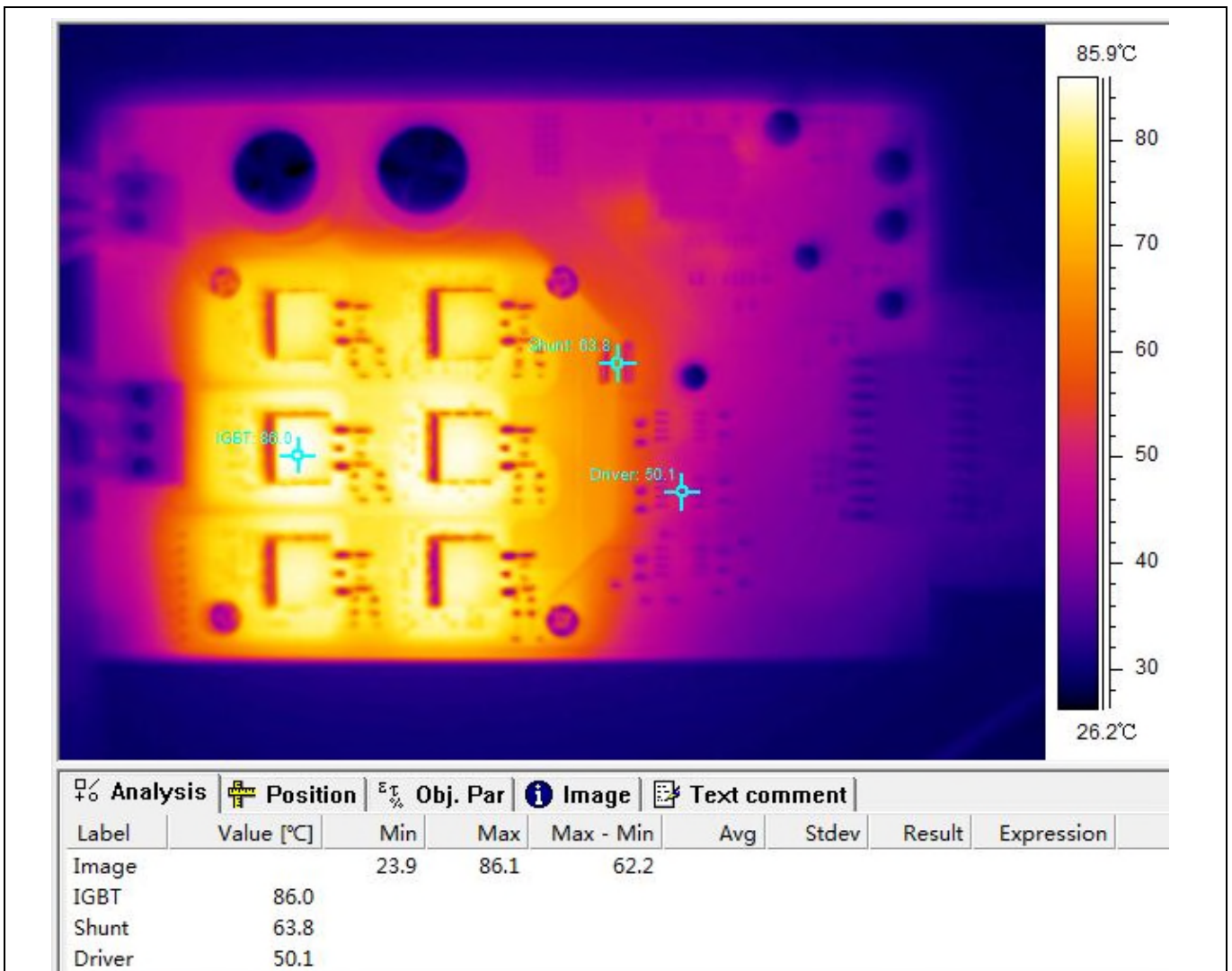

Figure 7 Thermal breakdown at 300 W input power

7 Circuit diagram of the EVAL-M1-2ED2106S

7.1 Schematic overview

The schematic overview is depicted in Figure 8.

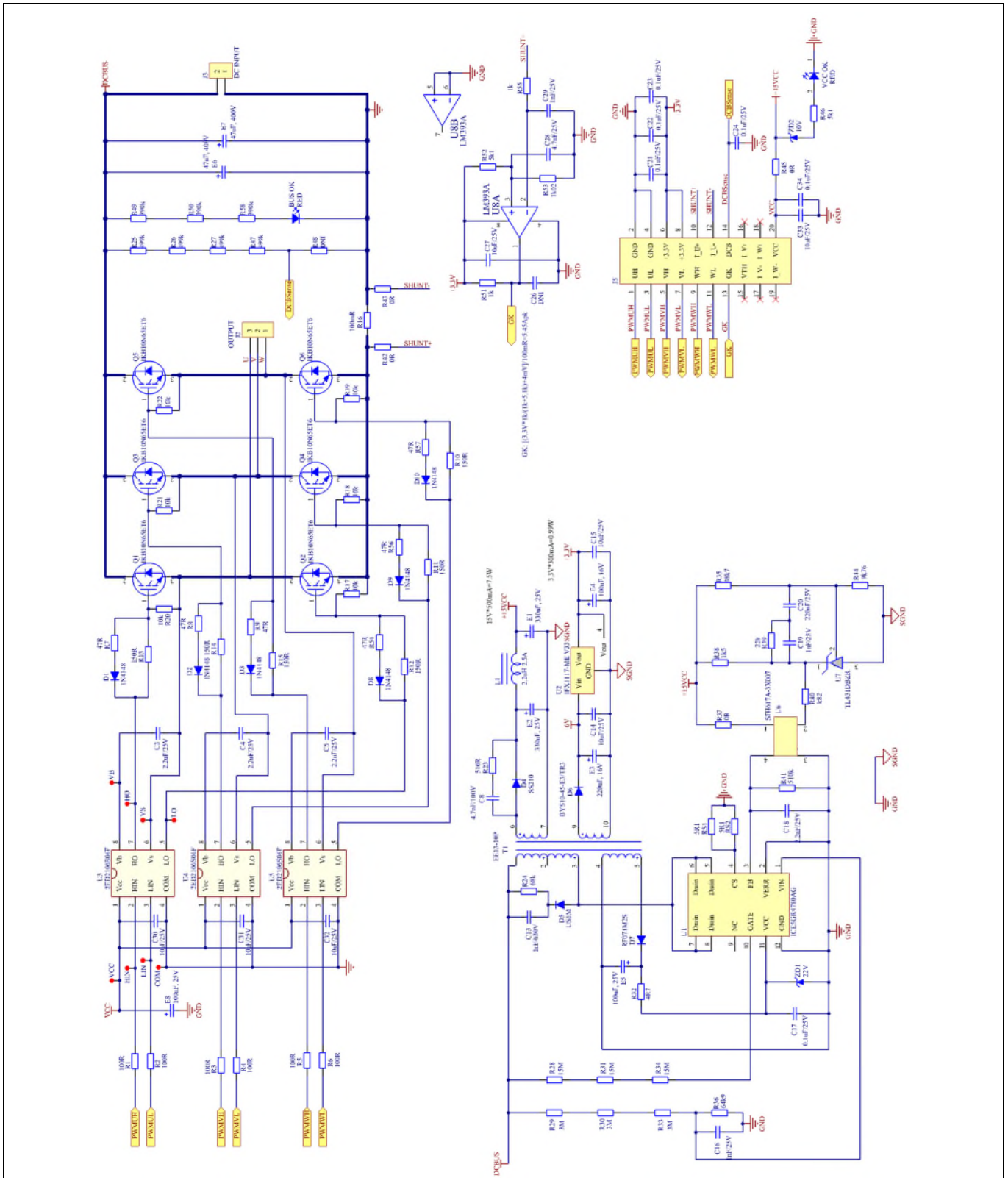

Figure 8 Schematic overview of the EVAL-M1-2ED2106S

EVAL-M1-2ED2106S User Manual
2ED2106S06F drive board for BLDC motor
Circuit diagram of the EVAL-M1-2ED2106S

7.2 Main power circuit

The gate drivers and IGBTs is designed as Figure 9. Each PWM signal to the gate driver's input involves a resistor in series to suppress the noise induced from the ground bouncing while the IGBT switching. The ON and OFF gate resistors are separated for an optimized tradeoff between the IGBT switching loss and system EMI performance.

The DC bus status is sampled by a resistor divider.

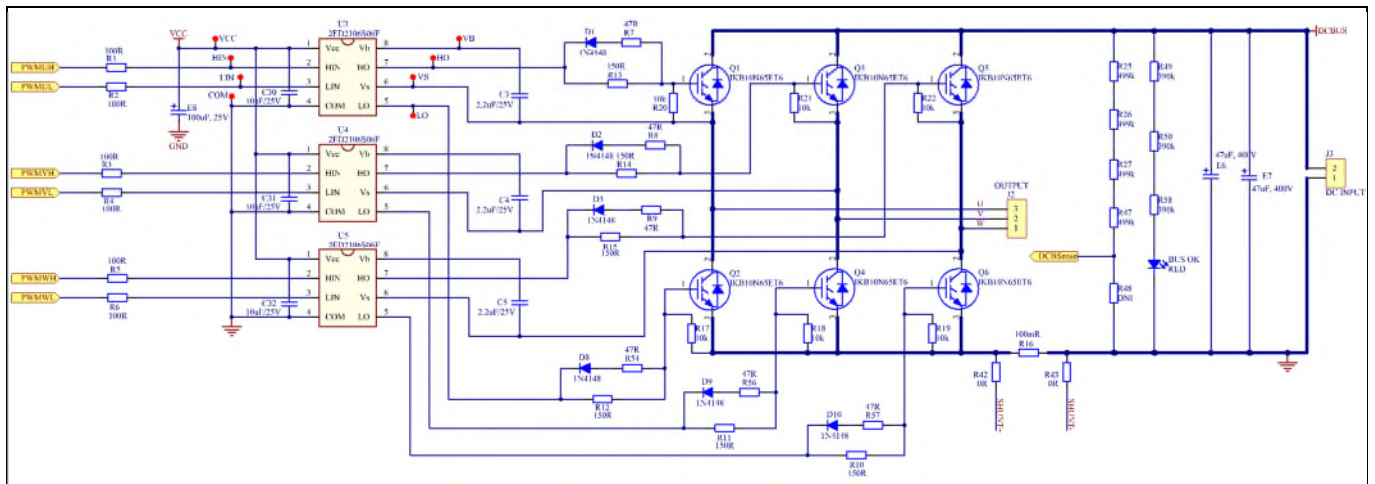

Figure 9 Main power circuit

7.3 OCP circuit

The overcurrent protection (OCP) function is necessary for motor drive applications. As configured in Figure 10, the output of the comparator LM393A shall flip-flop low when the single-shunt current is over 5.45 A. The generated gate kill (GK) signal is sent to the controller IC disabling all the gate driver PWM inputs to turn off the IGBTs.

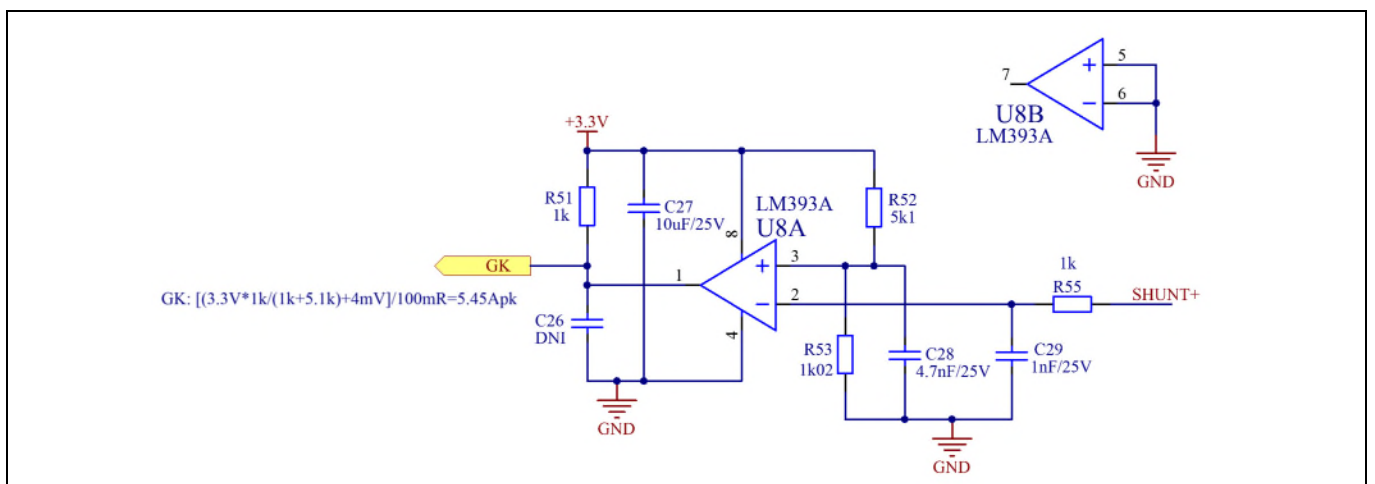

Figure 10 OCP circuit

The typical OCP waveform is captured in Figure 11. The gate drive signals are terminated immediately after the overcurrent event occurs.

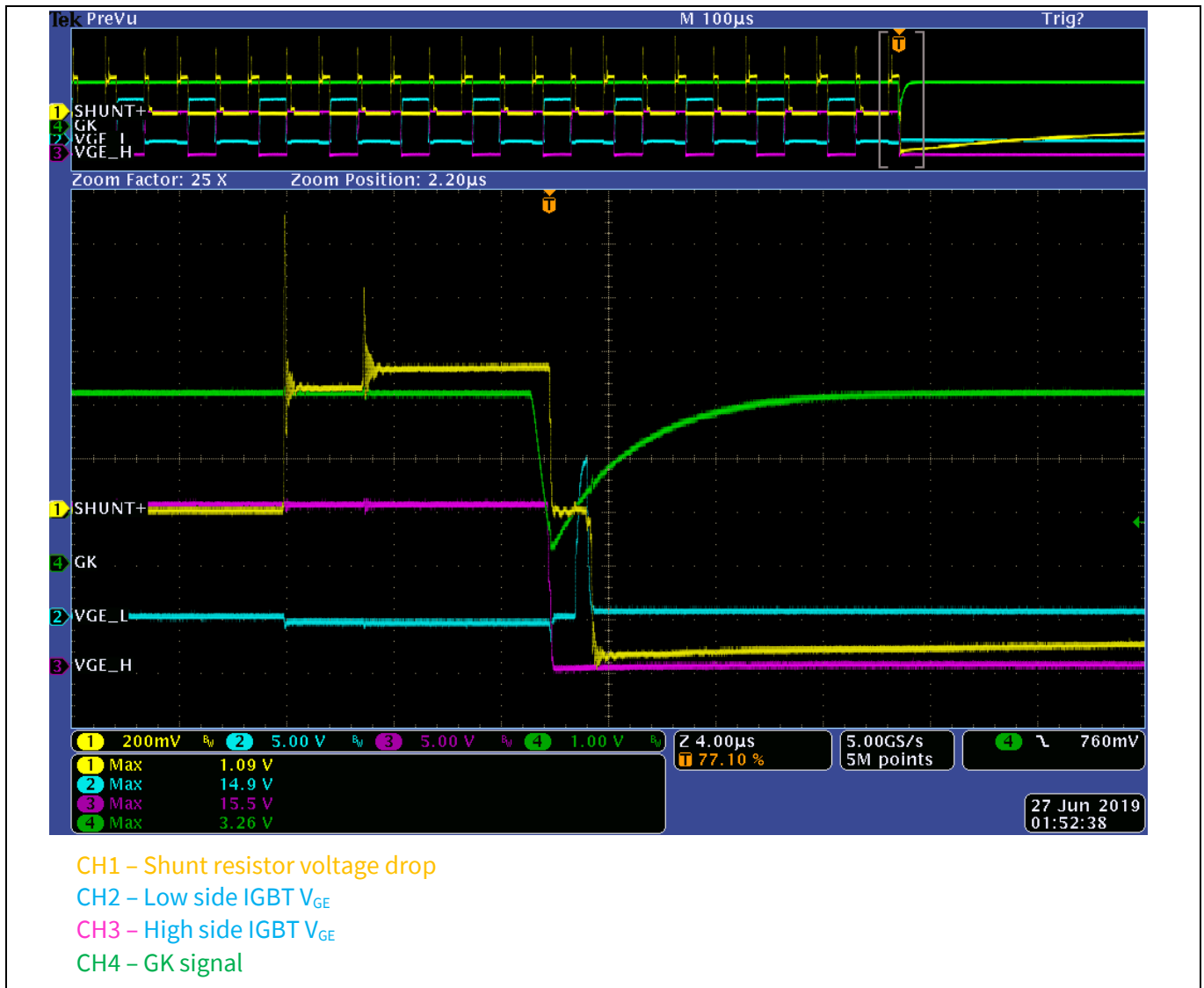

Figure 11 Test result - OCP

The IGBT6 short-circuit capability is only 3 μ s. Therefore in case of a short circuit, the IGBTs must be shut down within the withstand time limitation. The total short-circuit protection (SCP) delay time is the sum of the cascaded time intervals as below:

- Current sampling input filter time, which is set up by R55 and C29 with a time constant of 1 μ s.
- Comparator response time from the input step to the output GK flip-flop. Typical is 300 ns in this design.
- MCU delay time from receiving the GK signal to disable the PWMs. Typical is 1.3 μ s of the controller IMC101T (t_{GK} , defined in data sheet).
- Gate driver’s turn-off propagation delay time (t_{OFF}). Maximum is 300 ns of the 2ED2106S06F.
- The IGBT turn-off time, including the turn-off delay time $t_{d(off)}$ and fall time t_f , which is related to the turn-off gate resistor R_{goff} and the gate charge Q_G of the IGBT. It is less than 200 ns on this board.

The worst-case test of the short circuit was done by linking the high-side IGBT collector and emitter in advance of the system run. The short circuit would be triggered once the low-side IGBT turns on. In the bench test, the total SCP delay time of the board was around 2.5 μs (see Figure 12), which meets the IGBT short-circuit capability.

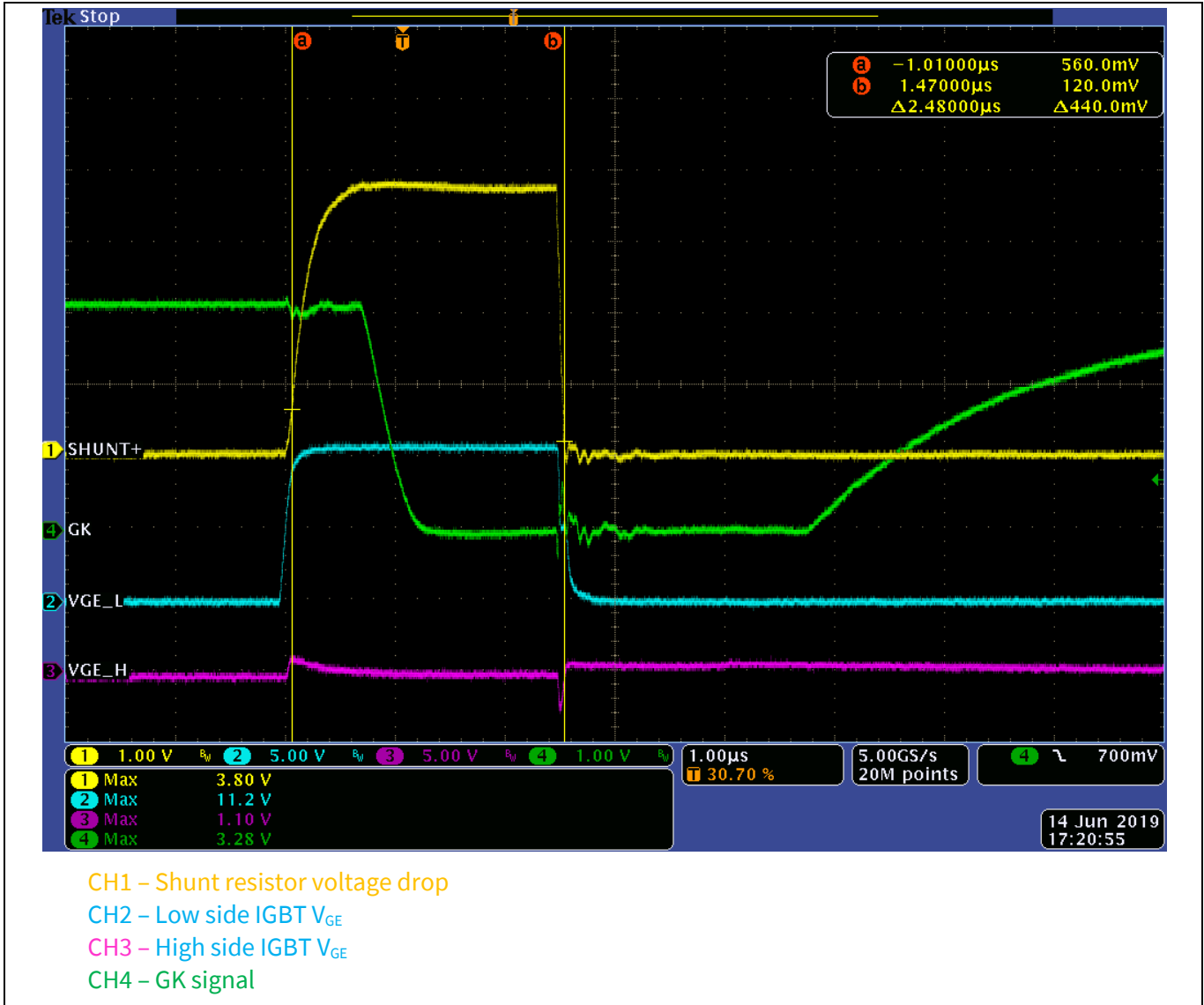

Figure 12 Test result - SCP

7.4 Auxiliary power supply circuit

As Figure 13 shows, the gate drivers' supply +15 V is generated from a flyback circuit with the CoolSET™ power controller ICE5GR4780AG. The +3.3 V for the external control board is regulated by the Infineon LDO IFX1117-ME from another winding of the transformer.

Although the auxiliary power supply adopts a flyback transformer and an opto-coupler, the primary and secondary side on this board are not isolated.

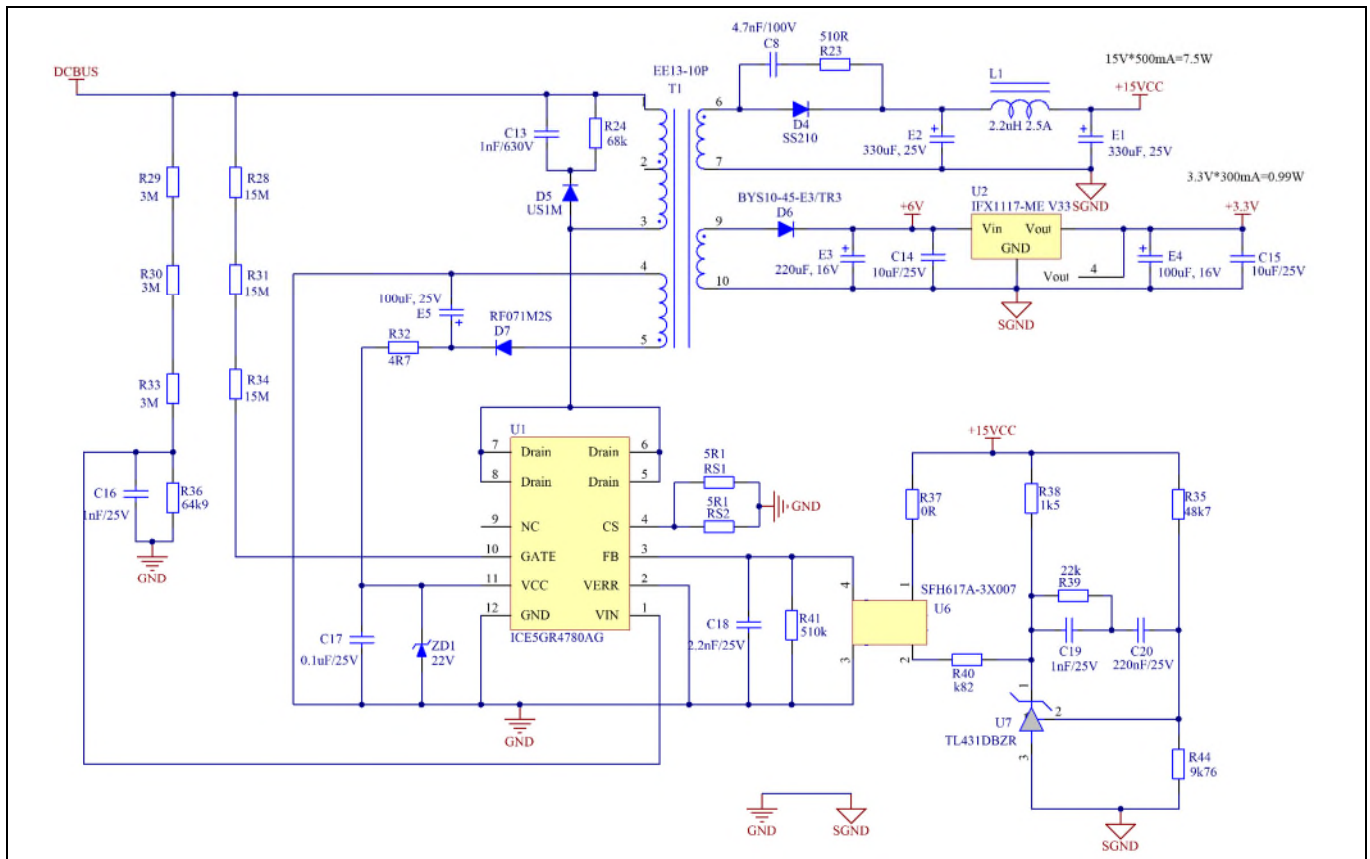

Figure 13 Auxiliary power supply circuit

8 PCB layout of the EVAL-M1-2ED2106S

The layout details of the EVAL-M1-2ED2106S can be seen in Figure 14, Figure 15, Figure 16 and Figure 17, respectively.

Some layout tips are indicated on this board:

- The power conductor paths such as DC+, GND, phase-out, etc. should be as thick as possible for a lower temperature rise and lower parasitic inductances.
- The shunt resistor is SMD-preferred with the lowest parasitic inductance for a smaller negative V_s during switching.
- The shunt resistor should be located where the LO-COM drive loop is as small as possible.
- The link conductor path of the high-side IGBT-E and low-side IGBT-C should be as thick and short as possible for a smaller parasitic inductance.
- The power ground and controller ground should be individually copper-filled (in the production process) and then shorted at the return of the shunt resistor. In this way the LO-COM drive loop parasitic inductance and the HIN/LIN-COM input signal loop parasitic inductance are both as small as possible (see Figure 15 and Figure 17).
- The V_{CC} and V_{BS} bypass capacitors should be close to the IC.
- Current sensing should be connected directly at the shunt-resistor terminals and sent to the controller interface as a differential pair.

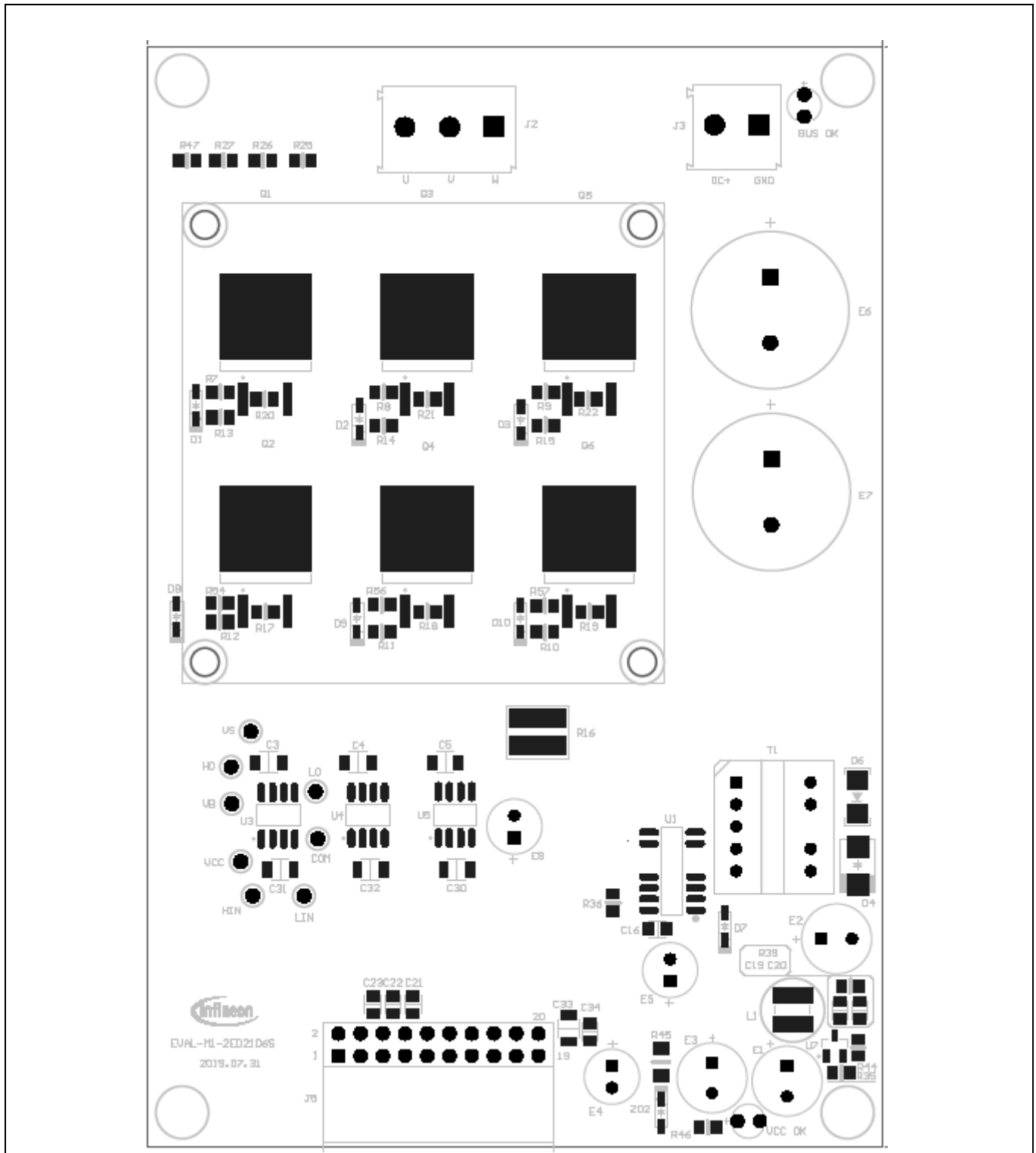

Figure 14 Top assembly drawing

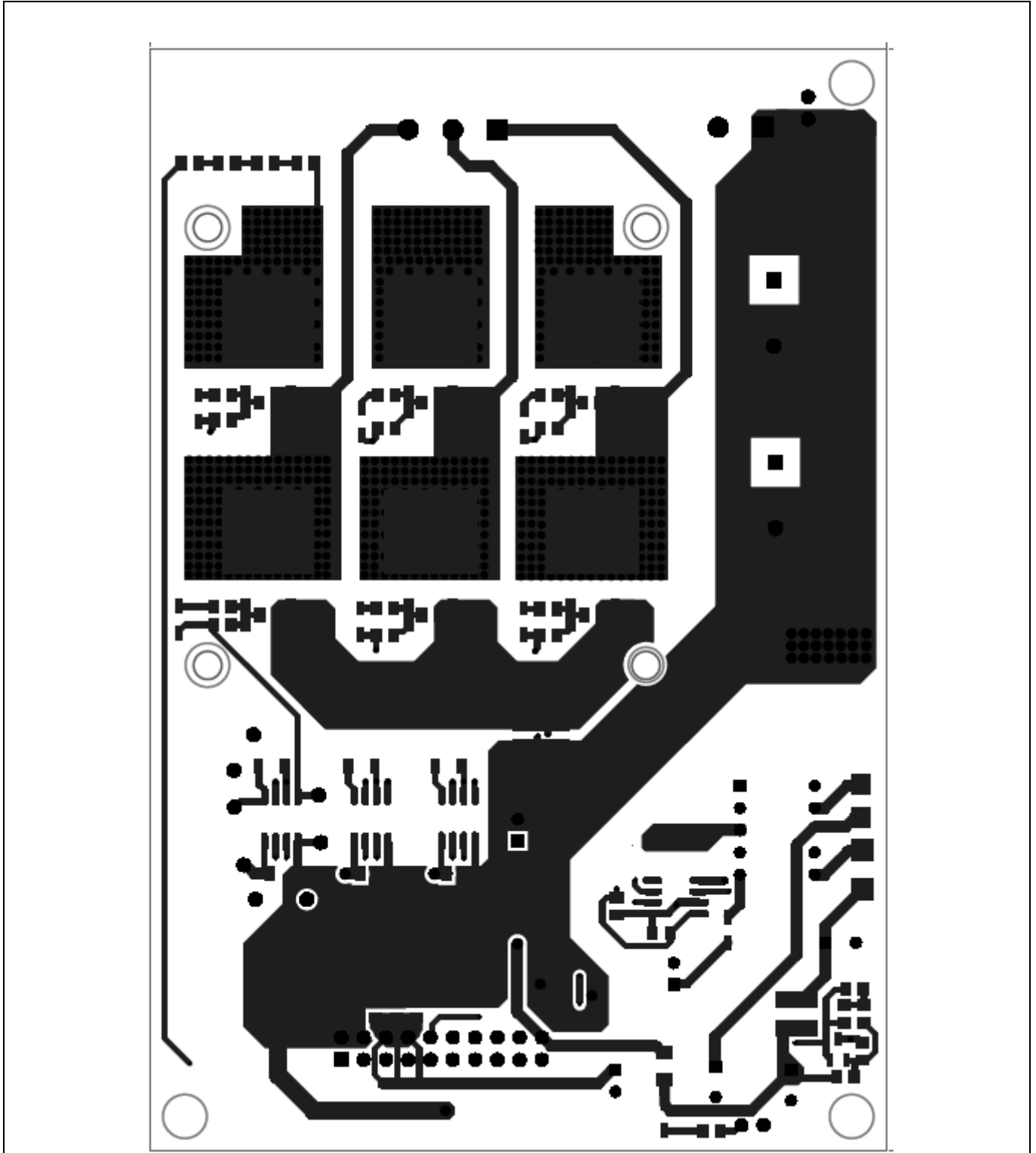

Figure 15 Top layer routing

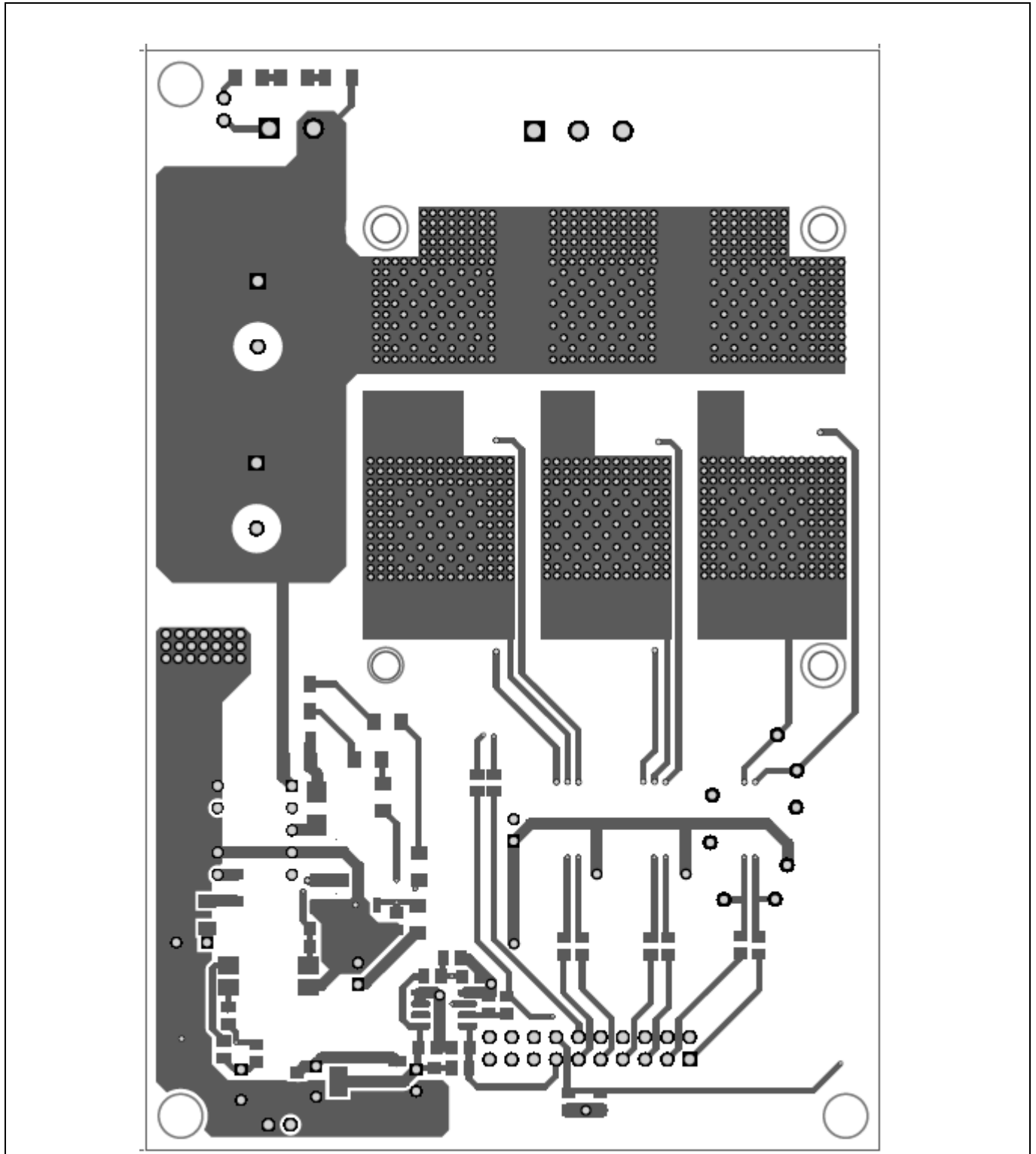

Figure 17 Bottom layer routing

Bill of material

9 Bill of material

All the components of the EVAL-M1-2ED2106S board are listed in Table 7.

Table 7 Bill of material

Designator	Description	Footprint	Vendor	Part number	Quantity
BUS OK, VCC OK	LED RED CLEAR ROUND T/H Diameter 3 mm P=2.54 mm		Würth Electronics	151034RS03000	2
C3, C4, C5	MLCC 2.2 uF 25 V X7R M	1206	Würth Electronics	885012208066	3
C8	MLCC 4.7 nF 100 V X7R M	1206	Würth Electronics	885012208110	1
C13	MLCC 1 nF 630 V X5R M	1206	Würth Electronics	885342208011	1
C14, C15, C27	MLCC 10 uF 16 V X5R M	0805	Würth Electronics	885012107014	3
C16, C19, C29	MLCC 1 nF 25 V X7R M	0805	Würth Electronics	885012207060	3
C17, C21, C22, C23, C24, C34	MLCC 0.1 uF 25 V X7R M	0805	Würth Electronics	885012207072	6
C18	MLCC 2.2 nF 25 V X7R M	0805	Würth Electronics	885012207062	1
C20	MLCC 220 nF 25 V X7R M	0805	Würth Electronics	885012207074	1
C26	DNI	0805			1
C28	MLCC 4.7 nF 25 V X5R M	0805	Würth Electronics	885012207064	1
C30, C31, C32, C33	MLCC 10 uF 25 V X5R M	1206	Würth Electronics	885012208069	4
COM, HIN, HO, LIN, LO, VB, VCC, VS	Test Point – Miniature White Diameter 2.54 mm		Keystone Electronics	5002	8
D1, D2, D3, D8, D9, D10	Small Signal Fast Switching Diode 150 mA 75 V	SOD-123	Vishay	1N4148W-G	6
D4	Schottky Diode 1.5 A 100 V	SMB	Vishay	SS210	1
D5	Ultra Fast Diode 1 A 1000 V	SMA	Vishay	US1M	1
D6	Schottky Diode 1.5 A 45 V	SMA	Vishay	BYS10-45	1
D7	Super Fast Diode 700 mA 200 V 25 nS	SOD-123	ROHM	RF071MM2S	1
E1, E2	ECAP AL LD 330 uF 25 V M	8*11.5 mm P3.5 mm	Würth Electronics	860020474013	2
E3	ECAP AL LD 220 uF 16 V M	8*11.5 mm P3.5 mm	Würth Electronics	860010374011	1

EVAL-M1-2ED2106S User Manual

2ED2106S06F drive board for BLDC motor



Bill of material

Designator	Description	Footprint	Vendor	Part number	Quantity
E4	ECAP AL LD 100 uF 16 V M	8*11.5 mm P3.5 mm	Würth Electronics	860240374004	1
E5, E8	ECAP AL 100 uF 25 V M	6.3*11 mm P2.5 mm	Würth Electronics	860020473008	2
E6, E7	ECAP AL 47 uF 400 V M	18*21 mm P7.5 mm	Würth Electronics	860241381005	2
HTSK	Heatsink 55x55 mm				1
J2	Horizontal Cable Entry with Rising Cage Clamp	3-way 5.08 mm	Würth Electronics	691216510003S	1
J3	Horizontal Cable Entry with Rising Cage Clamp	2-way 5.08 mm	Würth Electronics	691216510002S	1
J5	Angled Dual Socket Header	20-pin 2.54 mm	Würth Electronics	613020243121	1
L1	SMD Power Inductor 2.2 uH +/-20% 2.5 A	SMD	Würth Electronics	744773022	1
Q1, Q2, Q3, Q4, Q5, Q6	10 A 650 V IGBT6	D2PAK	Infineon	IKB10N65ET6	6
R1, R2, R3, R4, R5, R6,	RES SMD 100 Ω 5%	0805	Yageo	RC0805JR-07100RL	6
R10, R11, R12, R13, R14, R15	RES SMD 150 Ω 5%	0805	Yageo	RC0805JR-07150RL	6
R7, R8, R9, R54, R56, R57	RES SMD 47 Ω 5%	0805	Yageo	RC0805JR-0747RL	6
R16	RES SMD 100 mΩ 3 W 1%	1225	Viking	CS25FTE100	1
R17, R18, R19, R20, R21, R22	RES SMD 10 kΩ 5%	0805	Yageo	RC0805JR-0710KL	6
R23	RES SMD 510 Ω 5%	1206	Yageo	RC1206JR-07510RL	1
R24	RES SMD 68 kΩ 5%	1206	Yageo	RC1206JR-0768KL	1
R25, R26, R27, R47	RES SMD 499 kΩ 1%	0805	Yageo	RC0805FR-07499KL	4
R28, R31, R34	RES SMD 15 MΩ 5%	1206	Yageo	RC1206JR-0715ML	3
R29, R30, R33	RES SMD 3 MΩ 5%	1206	Yageo	RC1206JR-073ML	3
R32	RES SMD 4.7 Ω 5%	1206	Yageo	RC1206JR-074R7L	1
R35	RES SMD 48.7 kΩ 1%	0805	Yageo	RC0805FR-0748K7L	1
R36	RES SMD 64.9 kΩ 1%	0805	Yageo	RC0805FR-0764K9L	1
R37, R42, R43, R45	RES SMD 0 Ω 5%	0805	Yageo	RC0805JR-070RL	4
R38	RES SMD 1.5 kΩ 1%	0805	Yageo	RC0805FR-071K5L	1

EVAL-M1-2ED2106S User Manual
2ED2106S06F drive board for BLDC motor



Bill of material

Designator	Description	Footprint	Vendor	Part number	Quantity
R39	RES SMD 22 kΩ 1%	0805	Yageo	RC0805FR-0722KL	1
R40	RES SMD 820 Ω 1%	0805	Yageo	RC0805FR-07820RL	1
R41	RES SMD 510 kΩ 5%	0805	Yageo	RC0805JR-07510KL	1
R44	RES SMD 9.76 kΩ 1%	0805	Yageo	RC0805FR-079K76L	1
R46, R52	RES SMD 5.1 kΩ 1%	0805	Yageo	RC0805FR-075K1L	2
R48	DNI				1
R49, R50, R58	RES SMD 390 kΩ 5%	1206	Yageo	RC1206JR-07390KL	3
R51, R55	RES SMD 1 kΩ 5%	0805	Yageo	RC0805JR-071KL	2
R53	RES SMD 1.02 kΩ 1%	0805	Yageo	RC0805FR-071K02L	1
RS1, RS2	RES SMD 5.1 Ω 1%	1206	Yageo	RC1206FR-075R1L	2
T1	Flyback Transformer EE13 3.5 mH	EE13-10P	Würth Electronics	--	1
U1	CoolSET™ power controller	DSO-12	Infineon Technologies	ICE5GR4780AG	1
U2	LDO output 3.3 V	SOT-223-4	Infineon Technologies	IFX1117ME V33HTMA1	1
U3, U4, U5	650 V SOI high side and low side gate driver	DSO-8	Infineon Technologies	2ED2106S06F	3
U6	OptoCoupler 60 mA 70 V CTR 100%-200%	SMD-4, option 7	Vishay	SFH617A-3X007	1
U7	Precision Programmable Reference	SOT-23	Texas Instruments	TL431DBZR	1
U8	Dual Differential Comparator	SO-8	Texas Instruments	LM393ADR	1
ZD1	Zener Diode 22 V 500 mW	SOD-123	Vishay	MMSZ5251B	1
ZD2	Zener Diode 10 V 500 mW	SOD-123	Vishay	MMSZ5240B	1
Sil-pad	60*60 mm, thickness 0.23mm			SP900S	1

Reference

10 Reference

- [1] Data sheet of Infineon Technologies 2ED2106S06F
- [2] Data sheet of Infineon Technologies IR2106S
- [3] Data sheet of Infineon Technologies IRS2106S
- [4] Data sheet of Infineon Technologies IMC101T
- [5] Data sheet of Texas Instruments LM393A
- [6] Application Note AN2018-01 EVAL-M1-101T User's Manual

Note: All listed data sheets and application notes of Infineon parts are available for downloading from Infineon's website www.infineon.com/.



Revision history

Revision history

Document version	Date of release	Description of changes
1.0	2019-09-18	First release

Trademarks

All referenced product or service names and trademarks are the property of their respective owners.

Edition 2019-09-18

Published by

Infineon Technologies AG

81726 Munich, Germany

© 2019 Infineon Technologies AG.

All Rights Reserved.

Do you have a question about this document?

Email: erratum@infineon.com

Document reference

AN2019-19

IMPORTANT NOTICE

The information contained in this application note is given as a hint for the implementation of the product only and shall in no event be regarded as a description or warranty of a certain functionality, condition or quality of the product. Before implementation of the product, the recipient of this application note must verify any function and other technical information given herein in the real application. Infineon Technologies hereby disclaims any and all warranties and liabilities of any kind (including without limitation warranties of non-infringement of intellectual property rights of any third party) with respect to any and all information given in this application note.

The data contained in this document is exclusively intended for technically trained staff. It is the responsibility of customer's technical departments to evaluate the suitability of the product for the intended application and the completeness of the product information given in this document with respect to such application.

For further information on the product, technology delivery terms and conditions and prices please contact your nearest Infineon Technologies office (www.infineon.com).

WARNINGS

Due to technical requirements products may contain dangerous substances. For information on the types in question please contact your nearest Infineon Technologies office.

Except as otherwise explicitly approved by Infineon Technologies in a written document signed by authorized representatives of Infineon Technologies, Infineon Technologies' products may not be used in any applications where a failure of the product or any consequences of the use thereof can reasonably be expected to result in personal injury.

单击下面可查看定价，库存，交付和生命周期等信息

[>>Infineon\(英飞凌\)](#)