

# TVS Diode

Transient Voltage Suppressor Diodes

## ESD208-B1-02 Series

Ultra Low Clamping ESD / Transient Protection Diode

ESD208-B1-02EL  
ESD208-B1-02ELS

## Data Sheet

Revision 1.2, 2013-11-29  
Final

Power Management & Multimarket

**Revision History Revision 1.1, 2013-11-26**

Page or Item	Subjects (major changes since previous revision)
--------------	--

**Revision 1.2, 2013-11-29**

5	Update of Table 2-2)

**Trademarks of Infineon Technologies AG**

AURIX™, BlueMoon™, C166™, CanPAK™, CIPOS™, CIPURSE™, COMNEON™, EconoPACK™, CoolMOS™, CoolSET™, CORECONTROL™, CROSSAVE™, DAVE™, EasyPIM™, EconoBRIDGE™, EconoDUAL™, EconoPIM™, EiceDRIVER™, eupec™, FCOS™, HITFET™, HybridPACK™, I<sup>2</sup>RF™, ISOFACE™, IsoPACK™, MIPAQ™, ModSTACK™, my-d™, NovalithIC™, OmniTune™, OptiMOS™, ORIGA™, PRIMARION™, PrimePACK™, PrimeSTACK™, PRO-SIL™, PROFET™, RASIC™, ReverSave™, SatRIC™, SIEGET™, SINDRION™, SIPMOS™, SMARTi™, SmartLEWIS™, SOLID FLASH™, TEMPFET™, thinQ!™, TRENCHSTOP™, TriCore™, X-GOLD™, X-PMU™, XMM™, XPOSYS™.

**Other Trademarks**

Advance Design System™ (ADS) of Agilent Technologies, AMBA™, ARM™, MULTI-ICE™, KEIL™, PRIMECELL™, REALVIEW™, THUMB™, μVision™ of ARM Limited, UK. AUTOSAR™ is licensed by AUTOSAR development partnership. Bluetooth™ of Bluetooth SIG Inc. CAT-iq™ of DECT Forum. COLOSSUS™, FirstGPS™ of Trimble Navigation Ltd. EMV™ of EMVCo, LLC (Visa Holdings Inc.). EPCOS™ of Epcos AG. FLEXGO™ of Microsoft Corporation. FlexRay™ is licensed by FlexRay Consortium. HYPERTERMINAL™ of Hilgraeve Incorporated. IEC™ of Commission Electrotechnique Internationale. IrDA™ of Infrared Data Association Corporation. ISO™ of INTERNATIONAL ORGANIZATION FOR STANDARDIZATION. MATLAB™ of MathWorks, Inc. MAXIM™ of Maxim Integrated Products, Inc. MICROTEC™, NUCLEUS™ of Mentor Graphics Corporation. Mifare™ of NXP. MIPI™ of MIPI Alliance, Inc. MIPS™ of MIPS Technologies, Inc., USA. muRata™ of MURATA MANUFACTURING CO., MICROWAVE OFFICE™ (MWO) of Applied Wave Research Inc., OmniVision™ of OmniVision Technologies, Inc. Openwave™ Openwave Systems Inc. RED HAT™ Red Hat, Inc. RFMD™ RF Micro Devices, Inc. SIRIUS™ of Sirius Satellite Radio Inc. SOLARIS™ of Sun Microsystems, Inc. SPANSION™ of Spansion LLC Ltd. Symbian™ of Symbian Software Limited. TAIYO YUDEN™ of Taiyo Yuden Co. TEAKLITE™ of CEVA, Inc. TEKTRONIX™ of Tektronix Inc. TOKO™ of TOKO KABUSHIKI KAISHA TA. UNIX™ of X/Open Company Limited. VERILOG™, PALLADIUM™ of Cadence Design Systems, Inc. VLYNQ™ of Texas Instruments Incorporated. VXWORKS™, WIND RIVER™ of WIND RIVER SYSTEMS, INC. ZETEX™ of Diodes Zetex Limited.

Last Trademarks Update 2010-10-26

# 1 Ultra Low Clamping ESD / Transient Protection Diode

## 1.1 Features

- ESD / transient protection of signal lines in low voltage applications according to:
  - IEC61000-4-2 (ESD):  $\pm 30$  kV air discharge,  $\pm 25$  kV contact discharge
  - IEC61000-4-4 (EFT):  $\pm 80$  A /  $\pm 4$  kV (5/50 ns)
  - IEC61000-4-5 (Surge):  $\pm 4$  A (8/20  $\mu$ s)
- Bi-directional, symmetrical working voltage up to  $V_{RWM} = \pm 3.3$  V
- Low capacitance:  $C_L = 6$  pF (typical)
- Very low clamping voltage due to extremely low dynamic resistance down to:  $R_{DYN} = 0.2 \Omega$  (typical)
- Pb-free (RoHS compliant) and halogen free package, very small form factor down to: 0.62 x 0.32 x 0.31 mm<sup>3</sup>



## 1.2 Application Examples

- Keypad, touchpad, buttons, convenience keys
- LCD displays, Camera, audio lines, mobile communication, Consumer products (E-Book, MP3, DVD, DSC...)
- Notebooks tablets and desktop computers and their peripherals

## 1.3 Product Description

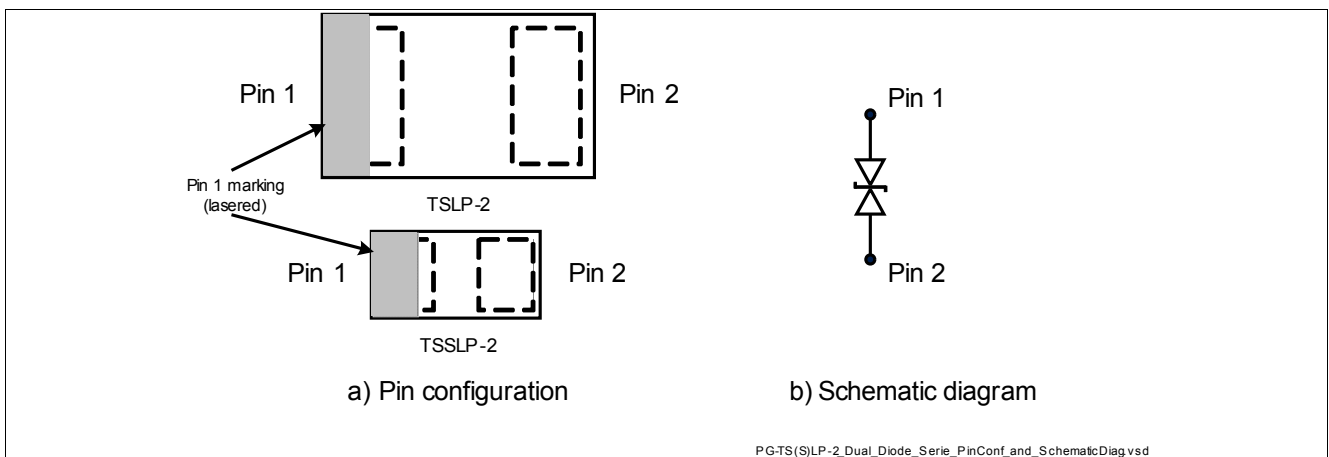

Figure 1-1 Pin Configuration and Schematic Diagram

Table 1-1 Ordering Information

Type	Package	Configuration	Marking code
ESD208-B1-02EL	TSLP-2-19	1 line, bi-directional	C
ESD208-B1-02ELS	TSSLP-2-3	1 line, bi-directional	<u>C</u>

## 2 Characteristics

**Table 2-1 Maximum Ratings at  $T_A = 25\text{ }^\circ\text{C}$ , unless otherwise specified <sup>1)</sup>**

Parameter	Symbol	Values			Unit
		Min.	Typ.	Max.	
ESD discharge <sup>2)</sup> air contact	$V_{ESD}$	–	–	30 25	kV
Peak pulse current ( $t_p = 8/20\text{ }\mu\text{s}$ ) <sup>3)</sup>	$I_{PP}$	–	–	4	A
Peak pulse power ( $t_p = 8/20\text{ }\mu\text{s}$ ) <sup>3)</sup>	$P_{PK}$	–	–	30	W
Operating temperature range	$T_{OP}$	-55	–	125	$^\circ\text{C}$
Storage temperature	$T_{stg}$	-65	–	150	$^\circ\text{C}$

- 1) Device is electrically symmetrical
- 2)  $V_{ESD}$  according to IEC61000-4-2 ( $R = 330\text{ }\Omega$ ,  $C = 150\text{ pF}$ )
- 3)  $I_{PP}$  according to IEC61000-4-5 ( $t_p = 8/20\text{ }\mu\text{s}$ )

**Attention: Stresses above the max. values listed here may cause permanent damage to the device. Exposure to absolute maximum rating conditions for extended periods may affect device reliability. Maximum ratings are absolute ratings; exceeding only one of these values may cause irreversible damage to the integrated circuit.**

### 2.1 Electrical Characteristics at $T_A = 25\text{ }^\circ\text{C}$ , unless otherwise specified

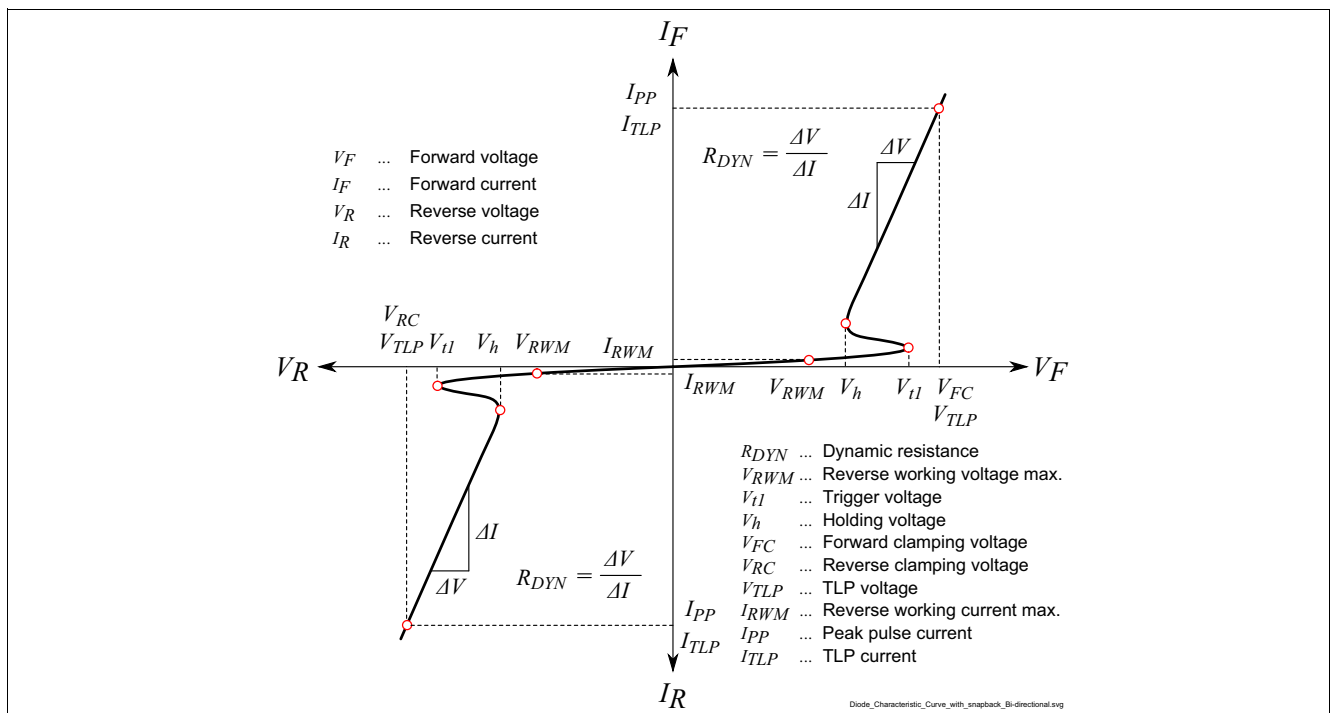

**Figure 2-1 Definitions of electrical characteristics**

**Table 2-2 DC Characteristics at  $T_A = 25\text{ }^\circ\text{C}$ , unless otherwise specified <sup>1)</sup>**

Parameter	Symbol	Values			Unit	Note / Test Condition
		Min.	Typ.	Max.		
Reverse working voltage	$V_{RWM}$	–	–	3.3	V	
Reverse current	$I_R$	–	<10	50	nA	$V_R = 3.3\text{ V}$
Trigger voltage	$V_{t1}$	3.65	–	–	V	
Holding voltage	$V_h$	3.65	4	–	V	$I_R = 10\text{ mA}$

1) Device is electrically symmetrical

**Table 2-3 AC Characteristics at  $T_A = 25\text{ }^\circ\text{C}$ , unless otherwise specified**

Parameter	Symbol	Values			Unit	Note / Test Condition
		Min.	Typ.	Max.		
Line capacitance	$C_L$	–	6	9	pF	$V_R = 0\text{ V}, f = 1\text{ MHz}$
			6	9		$V_R = 0\text{ V}, f = 1\text{ GHz}$

**Table 2-4 ESD and Surge Characteristics at  $T_A = 25\text{ }^\circ\text{C}$ , unless otherwise specified <sup>1)</sup>**

Parameter	Symbol	Values			Unit	Note / Test Condition
		Min.	Typ.	Max.		
Clamping voltage <sup>2)</sup>	$V_{CL}$	–	8	9.5	V	$I_{TLP} = 16\text{ A}, t_p = 100\text{ ns}$
		–	11	12.5		$I_{TLP} = 30\text{ A}, t_p = 100\text{ ns}$
Clamping voltage <sup>3)</sup>		–	4.8	6.3		$I_{PP} = 1\text{ A}, t_p = 8/20\text{ }\mu\text{s}$
		–	5.8	7.3		$I_{PP} = 3\text{ A}, t_p = 8/20\text{ }\mu\text{s}$
		–	6.6	8.1		$I_{PP} = 4\text{ A}, t_p = 8/20\text{ }\mu\text{s}$
Dynamic resistance <sup>2)</sup>	$R_{DYN}$	–	0.20	0.25	$\Omega$	$t_p = 100\text{ ns}$

1) Device is electrically symmetrical

2) Please refer to Application Note AN210 [1] TLP parameters:  $Z_0 = 50\text{ }\Omega$ ,  $t_p = 100\text{ ns}$ ,  $t_r = 0.6\text{ ns}$ , averaging window:  $t_1 = 30\text{ ns}$  to  $t_2 = 60\text{ ns}$ , extraction of dynamic resistance using least squares fit of TLP characteristics between  $I_{TLP1} = 10\text{ A}$  and  $I_{TLP2} = 40\text{ A}$ .

3)  $I_{PP}$  according to IEC61000-4-5 ( $t_p = 8/20\text{ }\mu\text{s}$ )

Typical Characteristics at  $T_A = 25\text{ }^\circ\text{C}$ , unless otherwise specified

### 3 Typical Characteristics at $T_A = 25\text{ }^\circ\text{C}$ , unless otherwise specified

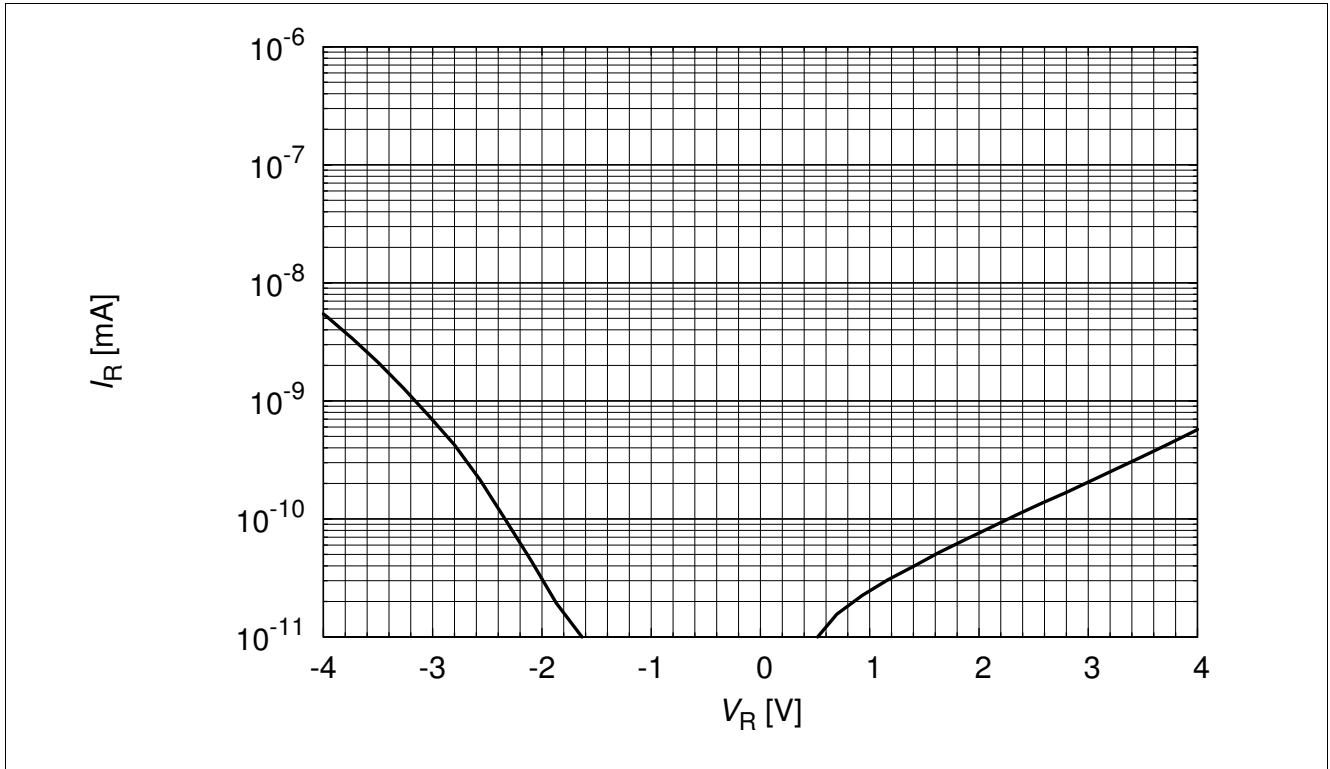

Figure 3-1 Reverse current:  $I_R = f(V_R)$

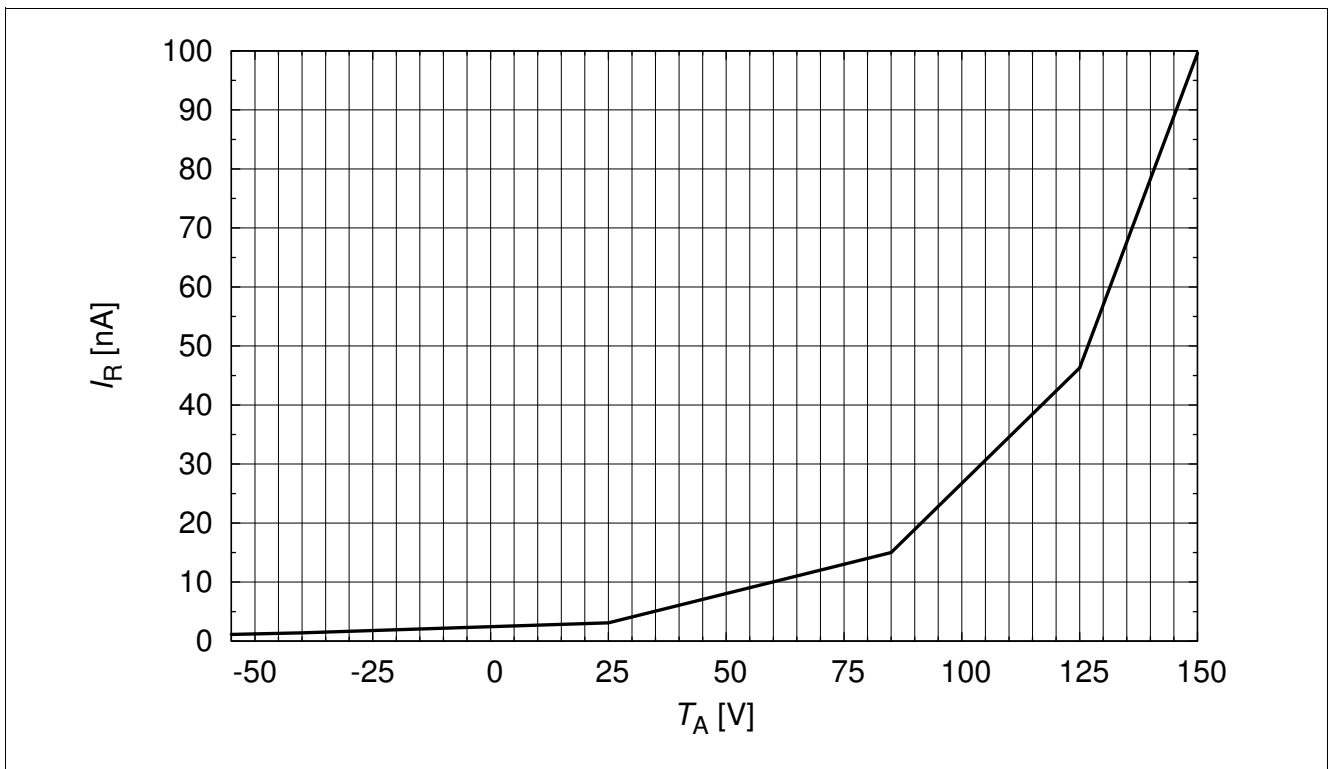

Figure 3-2 Reverse current:  $I_R = f(T_A)$ ,  $V_R = 3.3\text{ V}$

Typical Characteristics at  $T_A = 25\text{ }^\circ\text{C}$ , unless otherwise specified

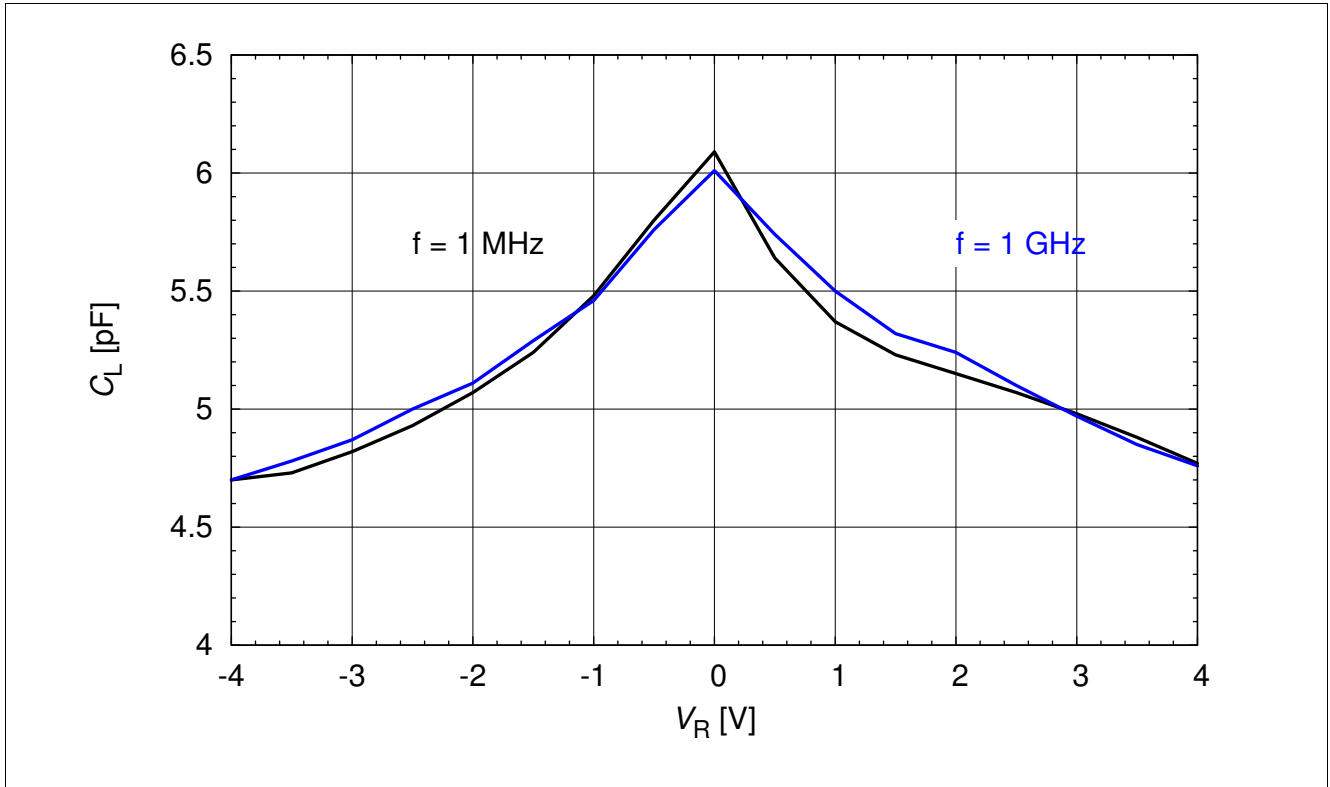

Figure 3-3 Line capacitance:  $C_L = f(V_R)$

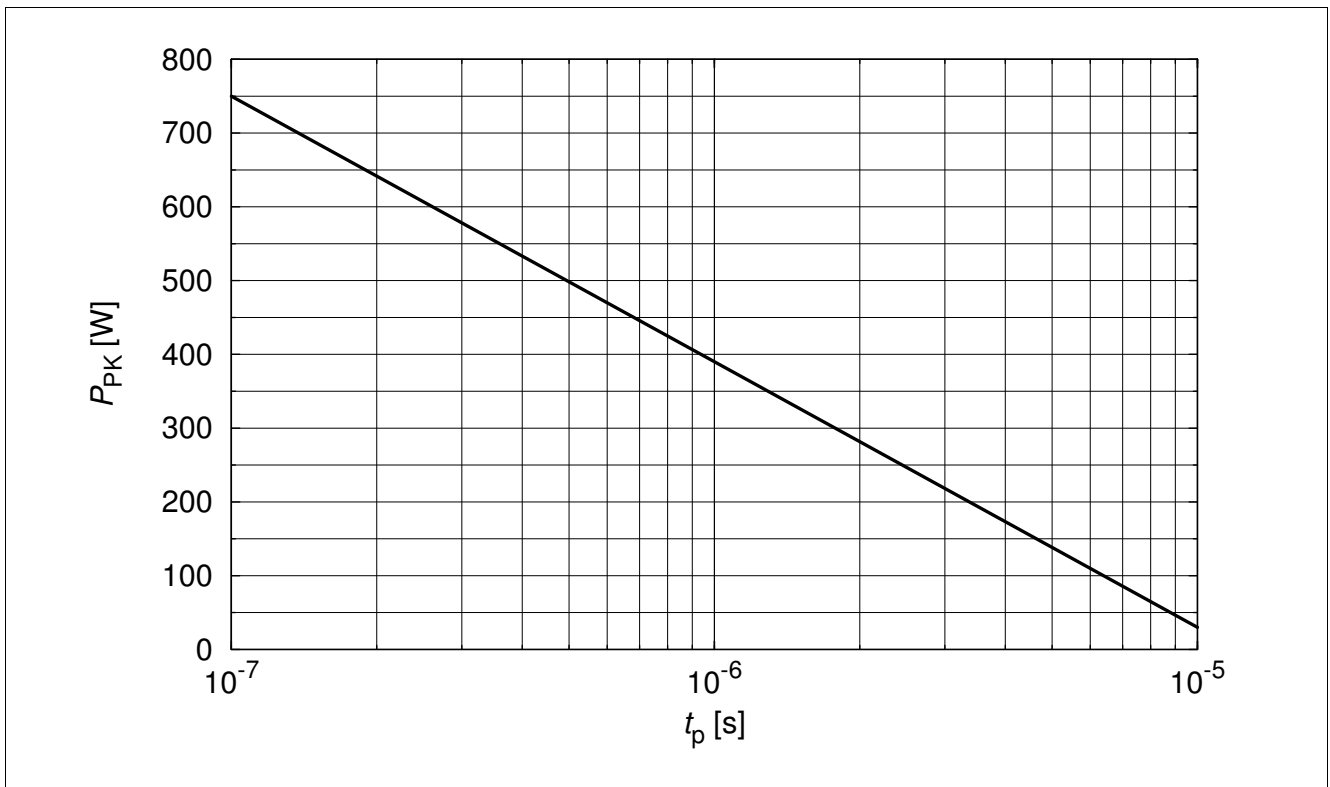
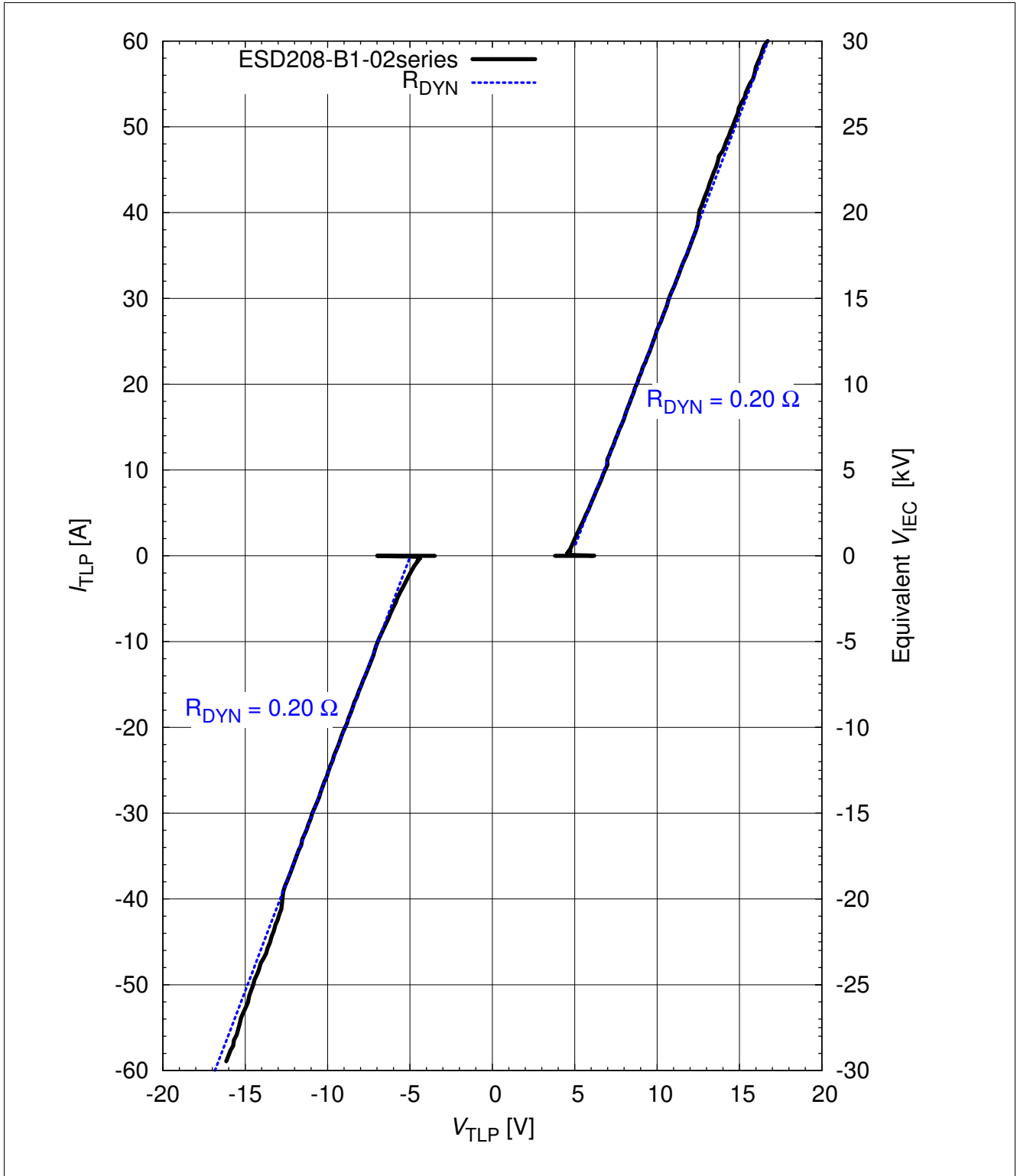

Figure 3-4 Peak pulse power:  $P_{PK} = f(t_p)$

Typical Characteristics at  $T_A = 25\text{ }^\circ\text{C}$ , unless otherwise specified



**Figure 3-5 Clamping voltage (TLP):  $I_{TLP} = f(V_{TLP})$  according ANSI/ESD STM5.5.1 - Electrostatic Discharge Sensitivity Testing using Transmission Line Pulse (TLP) Model. TLP conditions:  $Z_0 = 50\ \Omega$ ,  $t_p = 100\text{ ns}$ ,  $t_r = 0.6\text{ ns}$ ,  $I_{TLP}$  and  $V_{TLP}$  averaging window:  $t_1 = 30\text{ ns}$  to  $t_2 = 60\text{ ns}$ , extraction of dynamic resistance using squares fit to TLP characteristics between  $I_{TLP1} = 10\text{ A}$  and  $I_{TLP2} = 40\text{ A}$ . Please refer to Application Note AN210 [1]**



Typical Characteristics at  $T_A = 25\text{ }^\circ\text{C}$ , unless otherwise specified

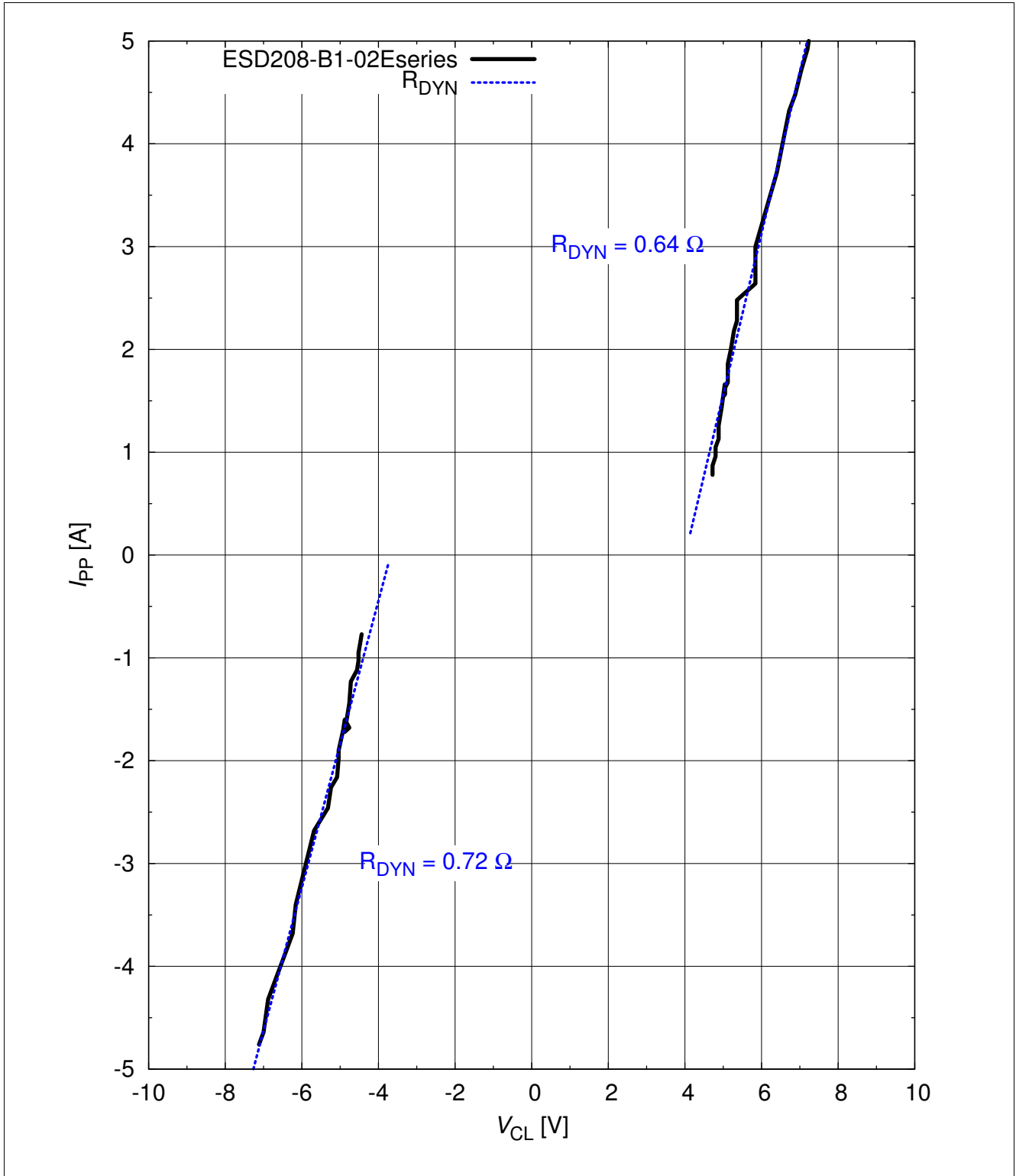

Figure 3-6 Pulse current (IEC61000-4-5) versus clamping voltage:  $I_{PP} = f(V_{CL})$

Typical Characteristics at  $T_A = 25\text{ }^\circ\text{C}$ , unless otherwise specified

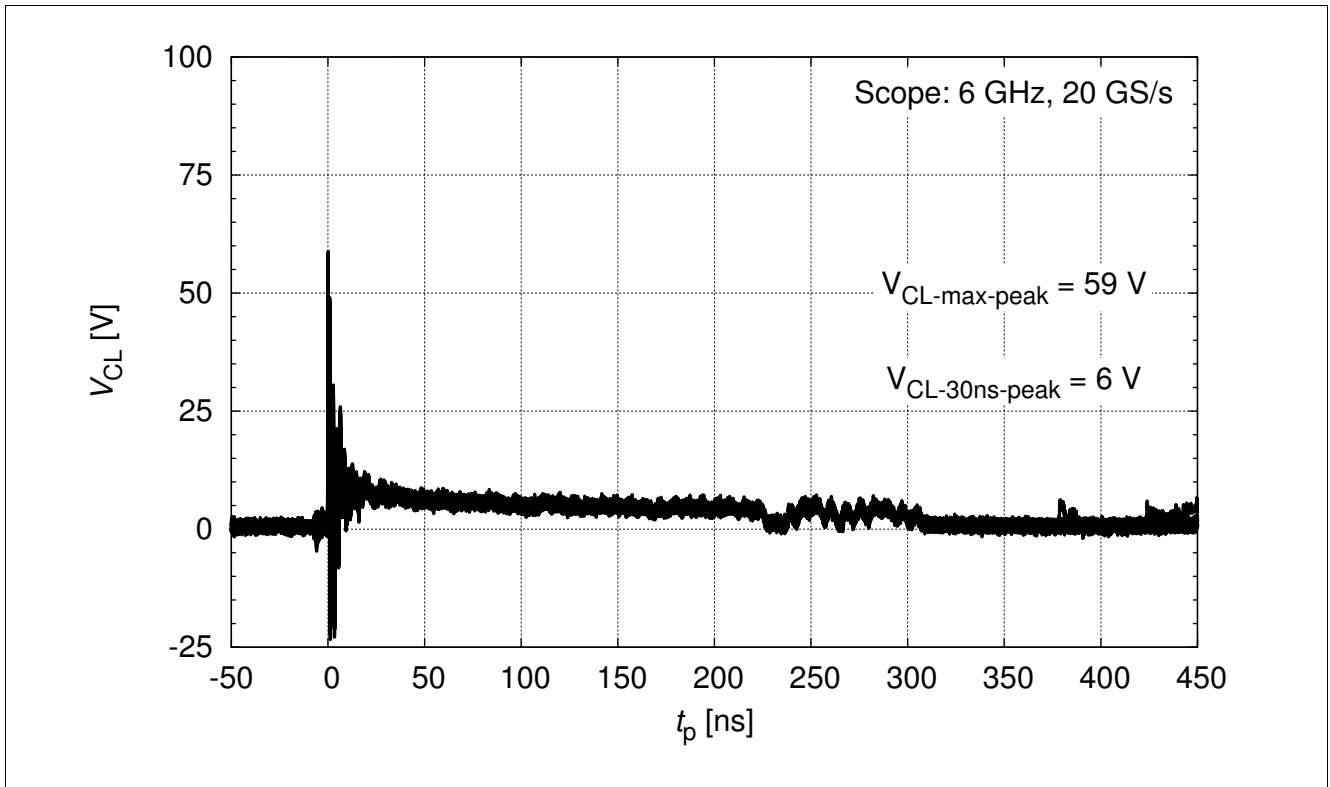

Figure 3-7 IEC61000-4-2 :  $V_{CL} = f(t)$ , 8 kV positive pulse from pin 1 to pin 2

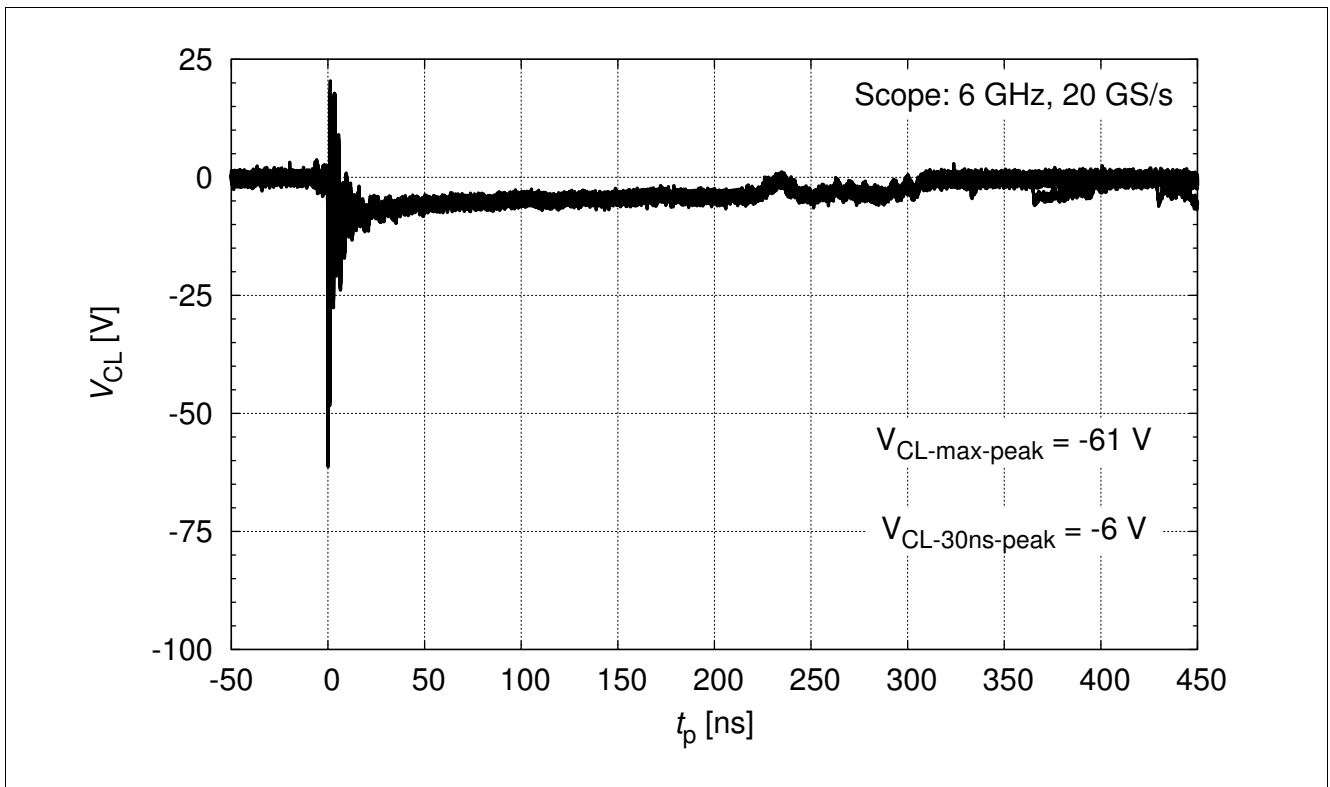

Figure 3-8 IEC61000-4-2 :  $V_{CL} = f(t)$ , 8 kV negative pulse from pin 1 to pin 2

Typical Characteristics at  $T_A = 25\text{ }^\circ\text{C}$ , unless otherwise specified

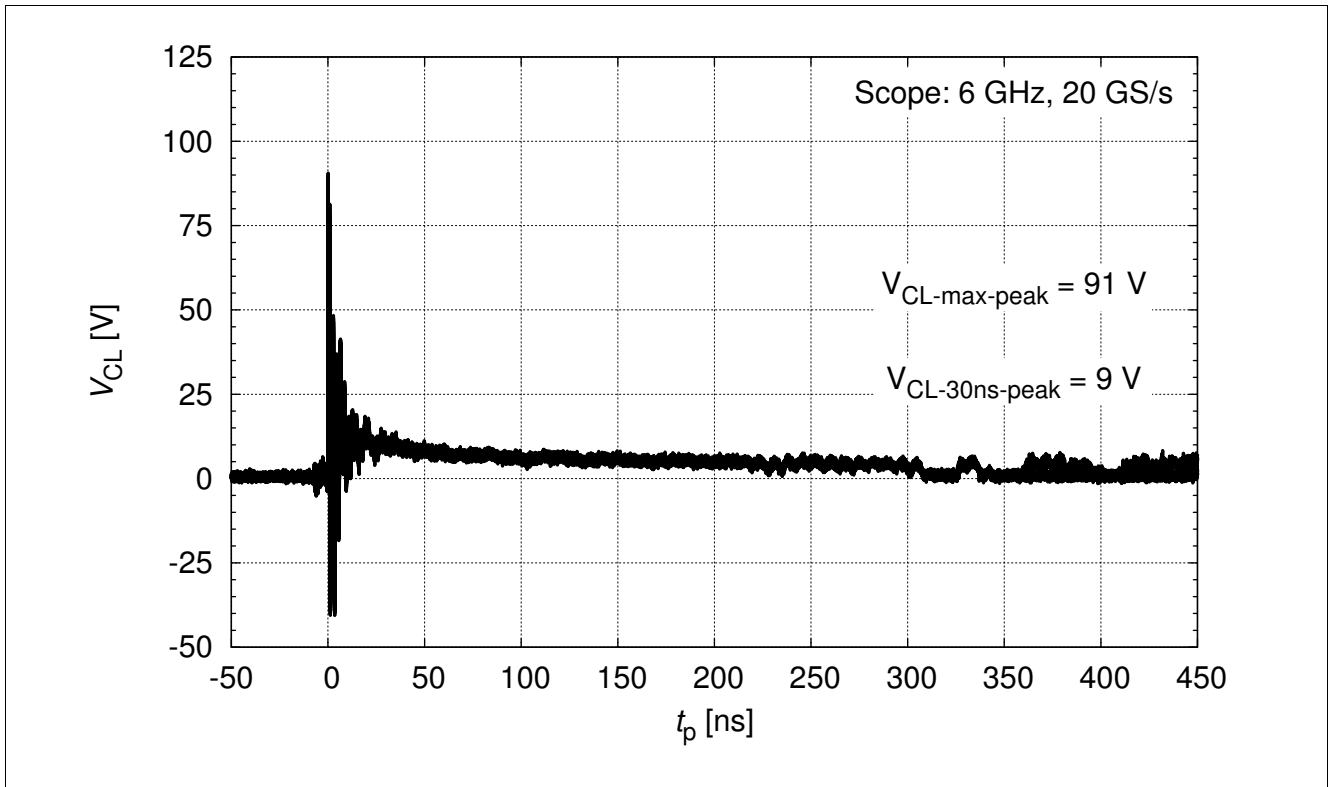

Figure 3-9 IEC61000-4-2 :  $V_{CL} = f(t)$ , 15 kV positive pulse from pin 1 to pin 2

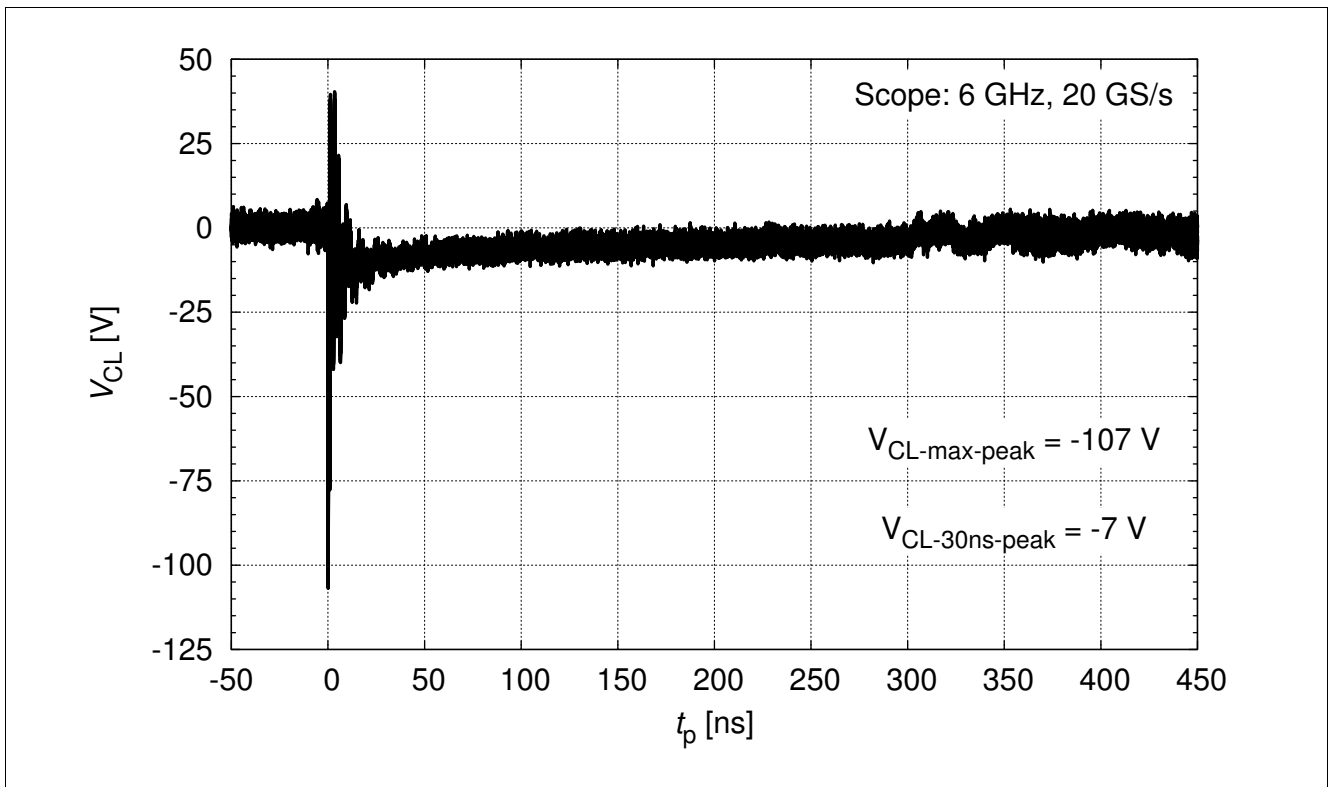

Figure 3-10 IEC61000-4-2 :  $V_{CL} = f(t)$ , 15 kV negative pulse from pin 1 to pin 2

## 4 Application Information

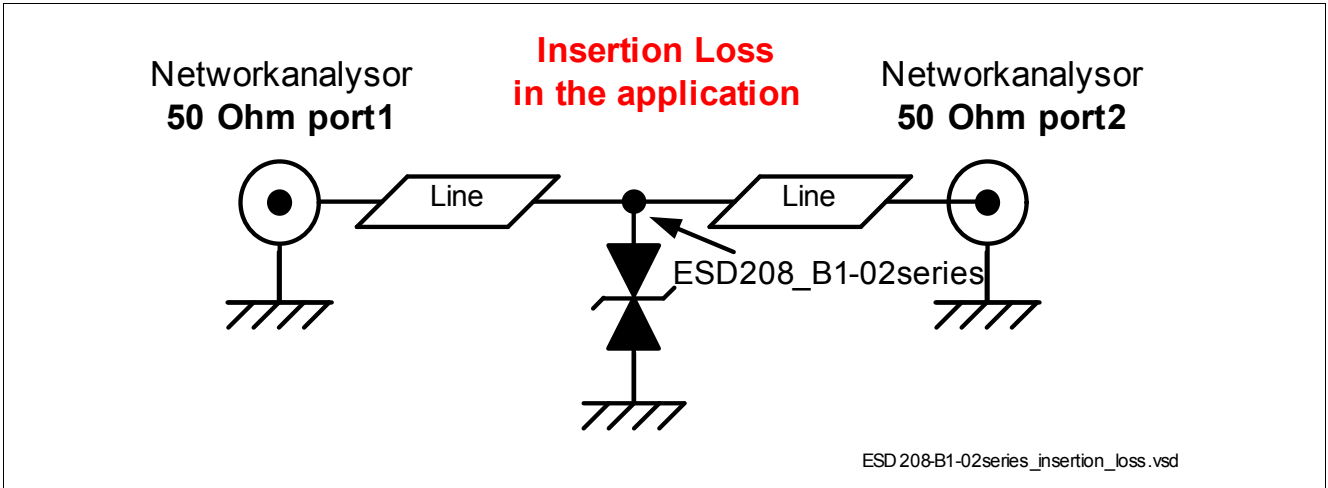

Figure 4-1 Insertion loss measured in 50 Ω environment

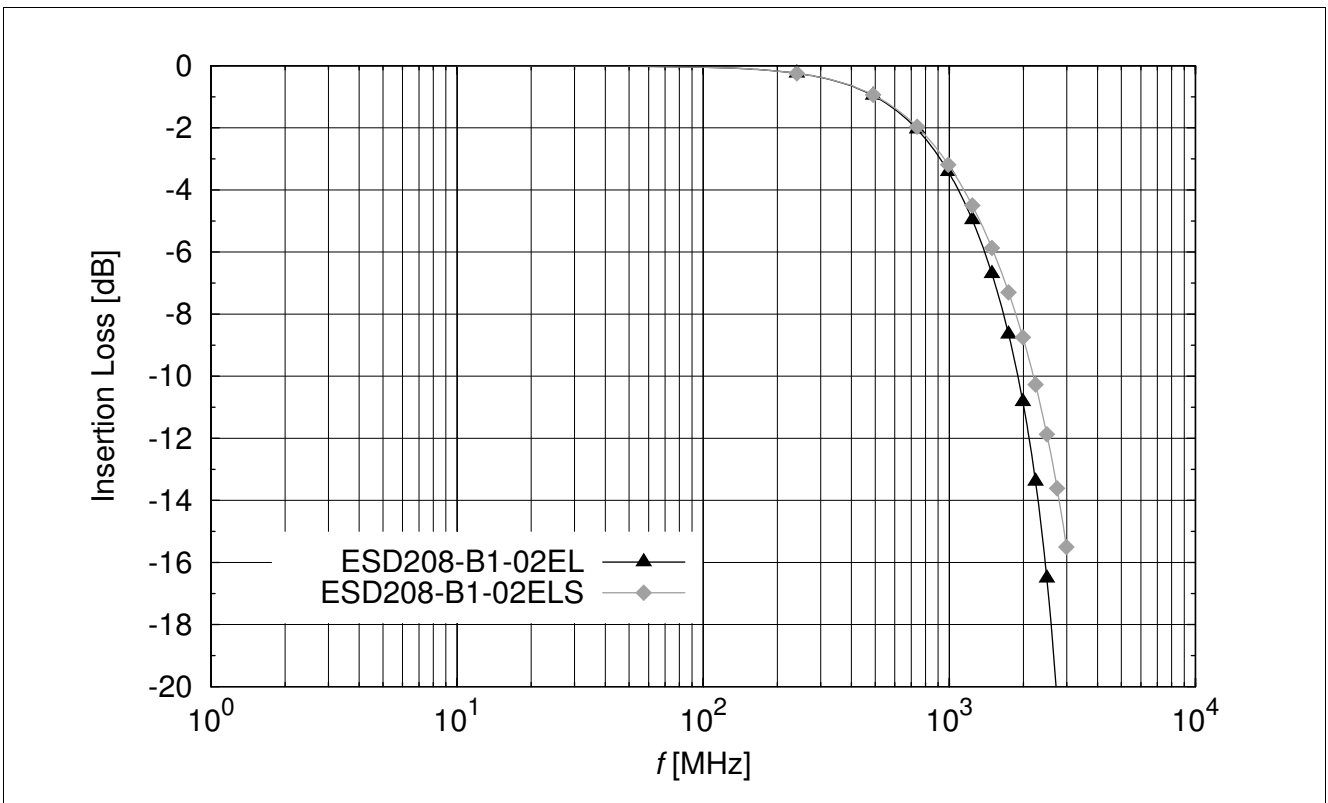

Figure 4-2 Insertion loss vs. frequency of ESD208-B1-02xx in a 50 Ω system

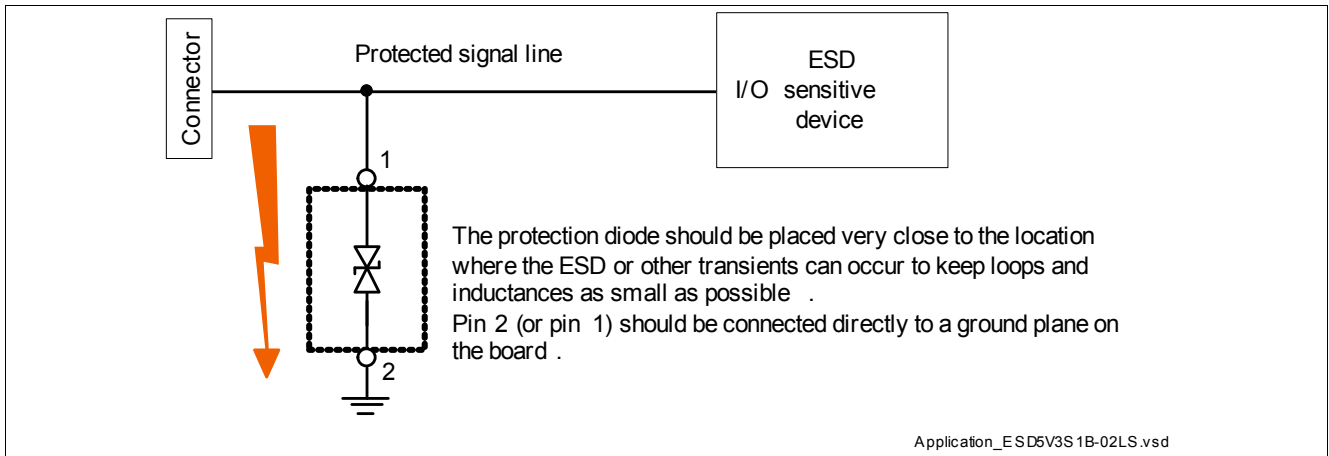

Figure 4-3 Single line, bi-directional ESD / Transient protection

## 5 Package Information

### 5.1 TSLP-2-19

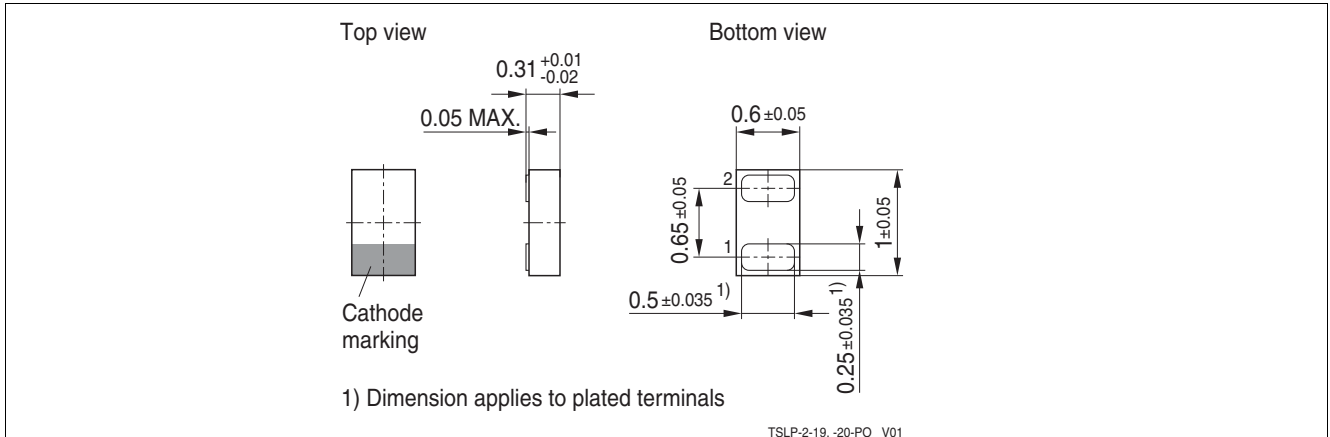

Figure 5-1 TSLP-2-19: Package overview (dimension in mm)

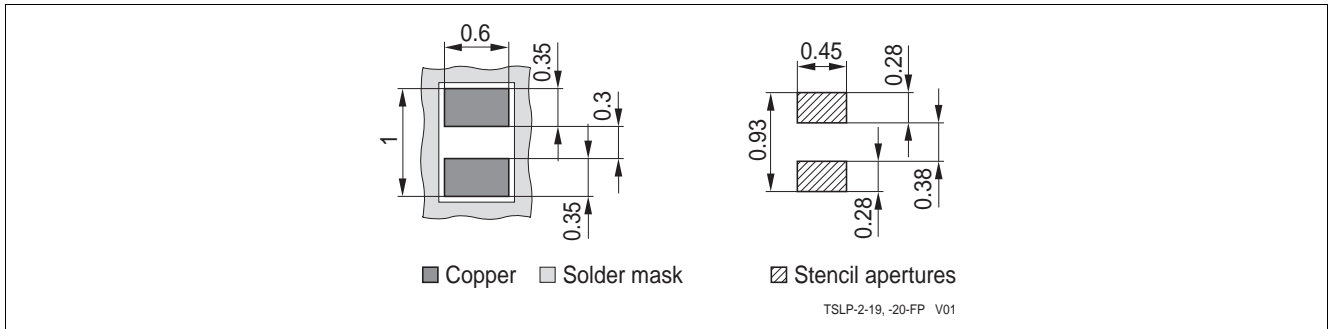

Figure 5-2 TSLP-2-19: Footprint (dimension in mm)

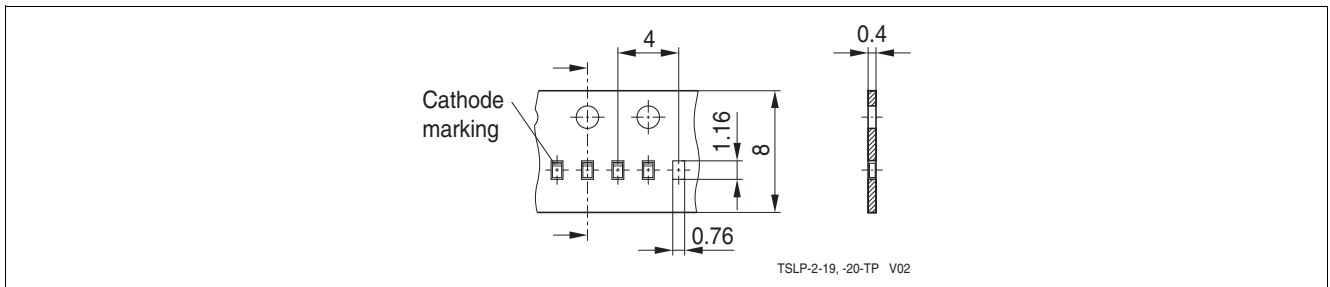

Figure 5-3 TSLP-2-19: Tape information (dimension in mm)

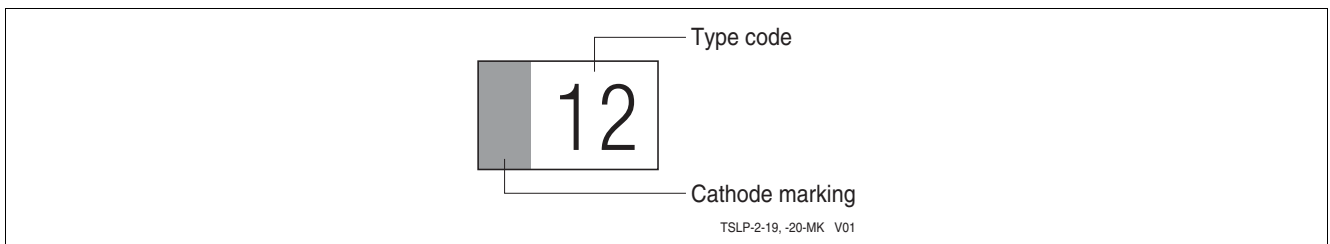

Figure 5-4 TSLP-2-19: Marking (example)

5.2 TSSLP-2-3

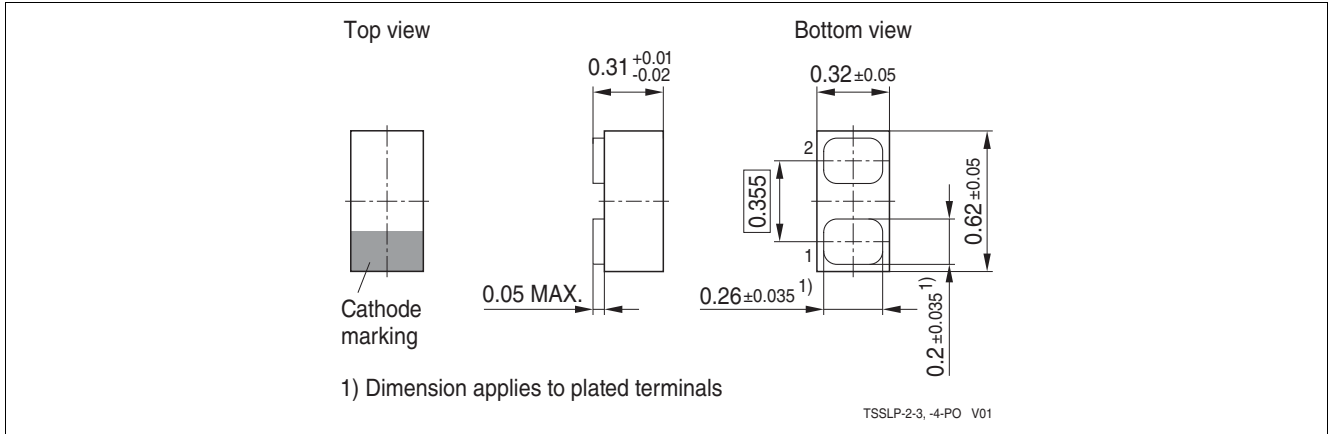

Figure 5-5 TSSLP-2-3: Package outline(dimension in mm)

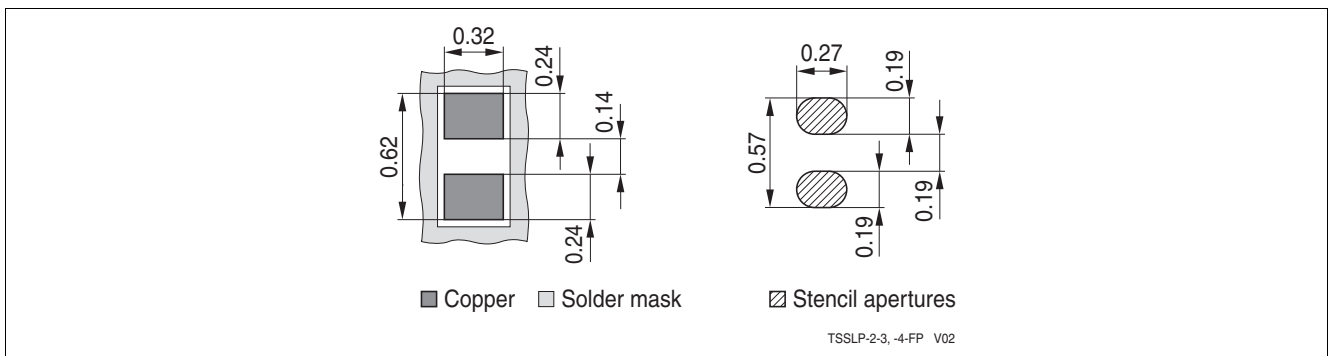

Figure 5-6 TSSLP-2-3: Footprint (dimension in mm)

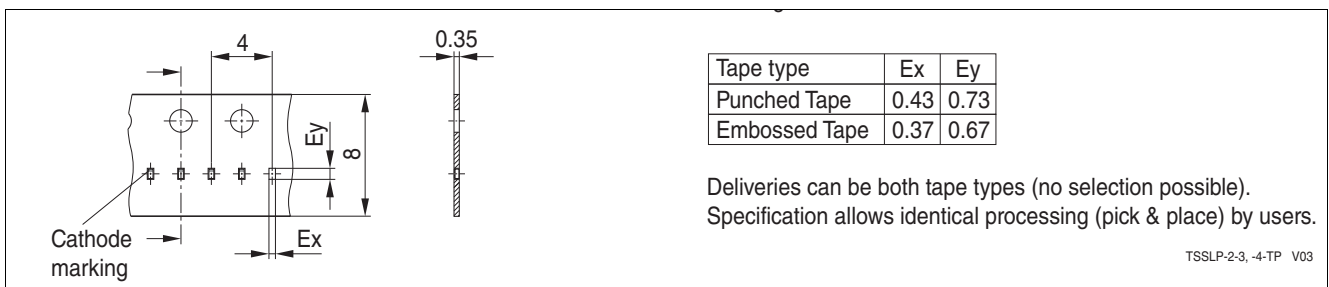

Figure 5-7 TSSLP-2-3: Tape information (dimension in mm)

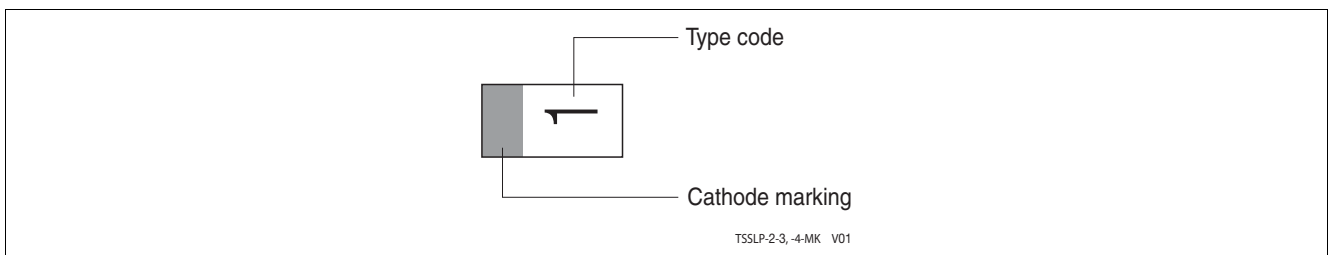

Figure 5-8 TSSLP-2-3: Marking (example)

**References**

- [1] Infineon AG - **Application Note AN210**: Effective ESD Protection design at System Level Using VF-TLP Characterization Methodology
- [2] Infineon AG - Recommendations for PCB Assembly of Infineon TSLP and TSSLP Packages



www.infineon.com

Published by Infineon Technologies AG

Downloaded From [Oneyac.com](https://www.oneyac.com)

单击下面可查看定价，库存，交付和生命周期等信息

[>>Infineon\(英飞凌\)](#)