

EiceDRIVER™ SENSE

High Voltage IGBT Driver for Automotive Applications

1EDI2010AS

Single Channel Isolated Driver

Data Sheet

Hardware Description
Rev 2.0, 2017-06-19

ATV PTS HVD

Edition 2017-06-19

**Published by
Infineon Technologies AG
81726 Munich, Germany**

**© 2017 Infineon Technologies AG
All Rights Reserved.**

Legal Disclaimer

The information given in this document shall in no event be regarded as a guarantee of conditions or characteristics. With respect to any examples or hints given herein, any typical values stated herein and/or any information regarding the application of the device, Infineon Technologies hereby disclaims any and all warranties and liabilities of any kind, including without limitation, warranties of non-infringement of intellectual property rights of any third party.

Information

For further information on technology, delivery terms and conditions and prices, please contact the nearest Infineon Technologies Office (www.infineon.com).

Warnings

Due to technical requirements, components may contain dangerous substances. For information on the types in question, please contact the nearest Infineon Technologies Office.

Infineon Technologies components may be used in life-support devices or systems only with the express written approval of Infineon Technologies, if a failure of such components can reasonably be expected to cause the failure of that life-support device or system or to affect the safety or effectiveness of that device or system. Life support devices or systems are intended to be implanted in the human body or to support and/or maintain and sustain and/or protect human life. If they fail, it is reasonable to assume that the health of the user or other persons may be endangered.

Revision History

Page or Item	Subjects (major changes since previous revision)
Rev 1.3.3, 2017-01-27	
Page 49	New chapter with Failure behavior 2.4.9.4 (former reset events)
Page 50	Reset Events Summary table updated due to new chapter 2.4.9.4 Table 2-15
Page 22	Updated figure 2-7.
Page 124	GATE pin characteristics merged in Table 5-11 with TON/TOFF characteristics.
Page 124	Added test conditions in Table 5-11 for TON/TOFF & GATE pin.
Page 124	Merged V_{PCLPG} and V_{PCLP} in Table 5-11 due to test conditions. Same for I_{PCLP} .
Page 124	Removed unprecise footnote in Table 5-11 .
Page 113	Updated values for weak pull down in Table 5-12 .
Page 128	Moved DESAT input voltage range to DESAT characteristics in Table 5-16 .
Page 39	Updated Links of Registers in Chapter 2.4.6.1 and 2.4.6.2.

Trademarks of Infineon Technologies AG

AURIX™, C166™, CanPAK™, CIPOS™, CIPURSE™, EconoPACK™, CoolMOS™, CoolSET™, CORECONTROL™, CROSSAVE™, DAVE™, EasyPIM™, EconoBRIDGE™, EconoDUAL™, EconoPIM™, EiceDRIVER™, eupec™, FCOS™, HITFET™, HybridPACK™, I²RF™, ISOFACE™, IsoPACK™, MIPAQ™, ModSTACK™, my-d™, NovalithIC™, OptiMOS™, ORIGA™, PRIMARION™, PrimePACK™, PrimeSTACK™, PRO-SIL™, PROFET™, RASIC™, ReverSave™, SatRIC™, SIEGET™, SINDRION™, SIPMOS™, SmartLEWIS™, SOLID FLASH™, TEMPFET™, thinQ!™, TRENCHSTOP™, TriCore™.

Other Trademarks

Advance Design System™ (ADS) of Agilent Technologies, AMBA™, ARM™, MULTI-ICE™, KEIL™, PRIMECELL™, REALVIEW™, THUMB™, μ Vision™ of ARM Limited, UK. AUTOSAR™ is licensed by AUTOSAR development partnership. Bluetooth™ of Bluetooth SIG Inc. CAT-iq™ of DECT Forum. COLOSSUS™, FirstGPS™ of Trimble Navigation Ltd. EMV™ of EMVCo, LLC (Visa Holdings Inc.). EPCOS™ of Epcos AG. FLEXGO™ of Microsoft Corporation. FlexRay™ is licensed by FlexRay Consortium. HYPERTERMINAL™ of Hilgraeve Incorporated. IEC™ of Commission Electrotechnique Internationale. IrDA™ of Infrared Data Association Corporation. ISO™ of INTERNATIONAL ORGANIZATION FOR STANDARDIZATION. MATLAB™ of MathWorks, Inc. MAXIM™ of Maxim Integrated Products, Inc. MICROTEC™, NUCLEUS™ of Mentor Graphics Corporation. Mifare™ of NXP. MIPI™ of MIPI Alliance, Inc. MIPS™ of MIPS Technologies, Inc., USA. muRata™ of MURATA MANUFACTURING CO., MICROWAVE OFFICE™ (MWO) of Applied Wave Research Inc., OmniVision™ of OmniVision Technologies, Inc. Openwave™ Openwave Systems Inc. RED HAT™ Red Hat, Inc. RFMD™ RF Micro Devices, Inc. SIRIUS™ of Sirius Satellite Radio Inc. SOLARIS™ of Sun Microsystems, Inc. SPANSION™ of Spansion LLC Ltd. Symbian™ of Symbian Software Limited. TAIYO YUDEN™ of Taiyo Yuden Co. TEAKLITE™ of CEVA, Inc. TEKTRONIX™ of Tektronix Inc. TOKO™ of TOKO KABUSHIKI KAISHA TA. UNIX™ of X/Open Company Limited. VERILOG™, PALLADIUM™ of Cadence Design Systems, Inc. VLYNQ™ of Texas Instruments Incorporated. VXWORKS™, WIND RIVER™ of WIND RIVER SYSTEMS, INC. ZETEX™ of Diodes Zetex Limited.

Last Trademarks Update 2011-02-24

Table of Contents

	Table of Contents	4
	List of Figures	7
	List of Tables	8
1	Product Definition	10
1.1	Overview	10
1.2	Feature Overview	10
1.3	Target Applications	11
2	Functional Description	12
2.1	Introduction	12
2.2	Pin Configuration and Functionality	13
2.2.1	Pin Configuration	13
2.2.2	Pin Functionality	15
2.2.2.1	Primary Side	15
2.2.2.2	Secondary Side	16
2.2.2.3	Pull Devices	17
2.3	Block Diagram	19
2.4	Functional Block Description	20
2.4.1	Power Supplies	20
2.4.2	Clock Domains	20
2.4.3	PWM Input Stage	21
2.4.4	SPI Interface	23
2.4.4.1	Overview	23
2.4.4.2	General Operation	24
2.4.4.3	Definitions	26
2.4.4.4	SPI Data Integrity Support	28
2.4.4.4.1	Parity Bit	28
2.4.4.4.2	SPI Error	28
2.4.4.5	Protocol Description	29
2.4.4.5.1	Command Catalog	29
2.4.4.5.2	Word Convention	29
2.4.4.5.3	ENTER_CMODE Command	30
2.4.4.5.4	ENTER_VMODE Command	30
2.4.4.5.5	EXIT_CMODE Command	30
2.4.4.5.6	NOP Command	31
2.4.4.5.7	READ Command	31
2.4.4.5.8	WRITEH	31
2.4.4.5.9	WRITEL	32
2.4.5	Operating Modes	33
2.4.5.1	General Operation	33
2.4.5.2	Definitions	34
2.4.5.2.1	Events and State Transitions	34
2.4.5.2.2	Emergency Turn-Off Sequence	35
2.4.5.2.3	Ready, Disabled, Enabled and Active State	35
2.4.5.3	Operation Modes Description	36
2.4.5.4	Activating the device after reset	37
2.4.5.5	Activating the device after an Event Class A or B	37
2.4.5.6	Debug Mode	38

2.4.6	Driver Functionality	39
2.4.6.1	Overview	39
2.4.6.2	Switching Sequence Description	44
2.4.6.3	Passive Clamping	46
2.4.7	Fault Notifications	46
2.4.8	EN Signal Pin	47
2.4.9	Internal Supervision	48
2.4.9.1	Lifesign watchdog	48
2.4.9.2	Oscillator Monitoring	48
2.4.9.3	Memory Supervision	48
2.4.9.4	Hardware Failure Behavior	49
2.4.10	Reset Events	50
2.4.11	Operation in Configuration Mode	51
2.4.11.1	Static Configuration Parameters	51
2.4.11.1.1	Configuration of the SPI Parity Check	51
2.4.11.1.2	Configuration of NFLTA and NFLTB clear mode	51
2.4.11.1.3	Configuration of NFLTA activation in case of Boundary Check event	51
2.4.11.1.4	Configuration of pin ADCT	51
2.4.11.1.5	Configuration of the STP Minimum Dead Time	52
2.4.11.1.6	Configuration of the Digital Channel	52
2.4.11.1.7	Configuration of the V_{BE} Compensation	52
2.4.11.1.8	Clamping of DESAT pin	52
2.4.11.1.9	Activation of the Pulse Suppressor	52
2.4.11.1.10	Configuration of the Verification Mode Time Out Duration	52
2.4.11.1.11	DESAT Threshold Level Configuration	52
2.4.11.1.12	UVLO2 Threshold Level Configuration	52
2.4.11.1.13	DACLP Operating Mode Configuration	52
2.4.11.1.14	Configuration of the ADC	52
2.4.11.1.15	Configuration of the DESAT Blanking Time	53
2.4.11.1.16	Configuration of the OCP Function	53
2.4.11.1.17	Configuration of the TTOFF sequences	53
2.4.11.1.18	Configuration of the TTON Delay TO Update	53
2.4.11.2	Dynamic Configuration	53
2.4.11.3	Delay Calibration	54
2.4.12	Low Latency Digital Channel	54
2.4.13	Analog Digital Converter	56
2.4.13.1	Overview	56
2.4.13.2	General Operation	58
2.4.13.3	Boundary Check	59
3	Protection and Diagnostics	60
3.1	Supervision Overview	60
3.2	Protection Functions: Category A	61
3.2.1	Desaturation Protection	61
3.2.2	Overcurrent Protection	63
3.2.3	External Enable	64
3.3	Protection Functions: Category B	65
3.3.1	Power Supply Voltage Monitoring	65
3.4	Protection Functions: Category C	66
3.4.1	Shoot Through Protection function	66
3.4.2	SPI Error Detection	67
3.5	Protection Functions: Category D	68

3.5.1	Operation in Verification Mode and Weak Active Mode	68
3.5.2	Weak Turn On	68
3.5.3	Internal Clock Supervision	70
4	Register Description	71
4.1	Primary Register Description	73
4.2	Secondary Registers Description	90
4.3	Read / Write Address Ranges	111
5	Specification	115
5.1	Typical Application Circuit	115
5.2	Absolute Maximum Ratings	118
5.3	Operating range	119
5.4	Thermal Characteristics	119
5.5	Electrical Characteristics	120
5.5.1	Power Supply	120
5.5.2	Internal Oscillators	121
5.5.3	Primary I/O Electrical Characteristics	122
5.5.4	Secondary I/O Electrical Characteristics	124
5.5.5	Switching Characteristics	126
5.5.6	Desaturation Protection	128
5.5.7	Overcurrent Protection	129
5.5.8	Low Latency Digital Channel	129
5.5.9	Error Detection Timing	130
5.5.10	SPI Interface	131
5.5.11	ADC	132
5.5.12	Insulation Characteristics	133
6	Package Information	134

List of Figures

Figure 2-1	EiceSENSE Pin Configuration	13
Figure 2-2	Block Diagram	19
Figure 2-3	PWM Input Stage	21
Figure 2-4	STP: Inhibition Time Definition	22
Figure 2-5	STP: Example of Operation	22
Figure 2-6	SPI Regular Bus Topology	24
Figure 2-7	SPI Daisy Chain Bus Topology	25
Figure 2-8	Response Answer Principle - Daisy Chain Topology	27
Figure 2-9	Response Answer Principle - Regular Topology	27
Figure 2-10	SPI Commands Overview	29
Figure 2-11	Operating Modes State Diagram	33
Figure 2-12	Output Stage Diagram of Principle	39
Figure 2-13	TTOFF: Principle of Operation	41
Figure 2-14	TTON: Principle of Operation	42
Figure 2-15	TTOFF: pulse suppressor aborting a turn-on sequence	43
Figure 2-16	Idealized Switching Sequence	45
Figure 2-17	Low Latency Digital Channel	55
Figure 2-18	Application Example NTC Measurement	56
Figure 2-19	Application Example: Diode Measurement	57
Figure 2-20	Application Example: V_{DCLINK} Measurement	57
Figure 3-1	DESAT Function: Diagram of Principle	61
Figure 3-2	DESAT Operation	62
Figure 3-3	DESAT Operation with DESAT clamping enabled	62
Figure 3-4	OCP Function: Principle of Operation	63
Figure 3-5	Shoot Through Protection: Principle of Operation	66
Figure 3-6	Idealized Weak Turn-On Sequence	69
Figure 5-1	Typical Application Example	117
Figure 5-2	SPI Interface Timing	131
Figure 6-1	Package Dimensions	134
Figure 6-2	Recommended Footprint	134

List of Tables

Table 2-1	Pin Configuration	13
Table 2-2	Internal pull devices	17
Table 2-3	SPI Command Catalog	29
Table 2-4	Word Convention	29
Table 2-5	ENTER_CMODE request and answer messages	30
Table 2-6	ENTER_VMODE request and answer messages	30
Table 2-7	EXIT_CMODE request and answer messages	30
Table 2-8	NOP request and answer messages	31
Table 2-9	READ request and answer messages	31
Table 2-10	WRITEH request and answer messages	31
Table 2-11	WRITEL request and answer messages	32
Table 2-12	Failure Notification Clearing	47
Table 2-13	System Supervision Overview	48
Table 2-14	Failure Events Summary	49
Table 2-15	Reset Events Summary	50
Table 2-16	Pin behavior (primary side) in case of reset condition	50
Table 2-17	Pin behavior (secondary side) in case of reset condition	50
Table 3-1	Safety Related Functions	60
Table 3-2	DESAT Protection Overview	61
Table 3-3	OCP Function Overview	63
Table 3-4	External Enable Function Overview	64
Table 3-5	Power Supply Voltage Monitoring Overview	65
Table 3-6	STP Overview	66
Table 3-7	SPI Error Detection Overview	67
Table 3-8	Primary Clock Supervision Overview	70
Table 4-1	Register Address Space	71
Table 4-2	Register Overview	71
Table 4-3	Bit Access Terminology	72
Table 4-4	Read Access Validity	111
Table 4-5	Write Access Validity	113
Table 5-1	Component Values	115
Table 5-2	Absolute Maximum Ratings	118
Table 5-3	Operating Conditions	119
Table 5-4	Thermal Characteristics	119
Table 5-5	Power Supplies Characteristics	120
Table 5-6	Internal Oscillators	121
Table 5-7	Electrical Characteristics for Pins: INP, INSTP, EN	122
Table 5-8	Electrical Characteristics for Pins: NRST/RDY, SCLK, SDI, NCS, DIO1 (input), ADCT	122
Table 5-9	Electrical Characteristics for Pins: SDO, DIO1 (output)	123
Table 5-10	Electrical Characteristics for Pins: NFLTA, NFLTB	123
Table 5-11	Electrical Characteristics for Pins: TON, TOFF & GATE	124
Table 5-12	Electrical Characteristics for Pins: DEBUG, DIO2 (input)	124
Table 5-13	Electrical Characteristics for Pins: DIO2, DACLP (Output)	124
Table 5-14	Electrical Characteristics for Pin: AIP	125
Table 5-15	Switching Characteristics	126
Table 5-16	DESAT characteristics	128
Table 5-17	OCP characteristics	129
Table 5-18	Digital channel characteristics	129
Table 5-19	Error Detection Timing	130

List of Tables

Table 5-20	SPI Interface Characteristics	131
Table 5-21	ADC parameter	132
Table 5-22	Isolation Characteristics referring to IEC 60747-5-2 (VDE 0884 - 10):2006-12	133
Table 5-23	Isolation Characteristics referring to UL 1577	133

1EDI2010AS

1 Product Definition

This color corresponds to the EiceSENSE.

1.1 Overview

The 1EDI2010AS is a high-voltage IGBT gate driver designed for motor drives above 5 kW. The 1EDI2010AS is based on Infineon's Coreless Transformer (CLT) technology, providing galvanic insulation between low voltage and high voltage domains. The device has been designed to support IGBT technologies up to 1200 V.

The 1EDI2010AS can be connected on the low voltage side ("primary" side) to 5 V logic. A standard SPI interface allows the logic to configure and to control the advanced functions implemented in the driver.

On the high voltage side ("secondary" side), the 1EDI2010AS is dimensioned to drive an external booster stage. Short propagation delays and controlled internal tolerances lead to minimal distortion of the PWM signal.

The 1EDI2010AS supports advanced functions (such as two level turn-on, two level turn-off, etc.), that can be controlled and configured via a standard SPI interface.

The internal 8-bit ADC (SAR) with programmable gain and offset enables the sensing of either the DC-link voltage, the phase voltage or of the temperature sensor located on the power module (such as NTC, Temperature Diode, etc.). The digitalized value can be read via the SPI interface on the primary side. The ADC allows thus to save significant costs on system level, since it removes the need for discrete isolation ICs.

The 1EDI2010AS can be used optimally with Infineon's 1EBN100XAE "EiceDRIVER™ Boost" booster stage family.



1.2 Feature Overview

The following features are supported by the 1EDI2010AS:

Functional Features

- Single Channel IGBT Driver.
- On-chip galvanic insulation (basic insulation as per DIN EN 60747-5-2).
- Support of existing IGBT technologies up to 1200V.
- Low propagation delay and minimal PWM distortion.
- Support of 5 V logic levels (primary side).
- Supports both negative and zero Volt V_{EE2} supply voltage.
- 16-bit Standard SPI interface (up to 2 Mbaud) with daisy chain support (primary side).

Product Name	Ordering Code	Package
1EDI2010AS	SP001299836	PG-DSO-36

- Enable input pin (primary side).
- Pseudo-differential inputs for critical signals (primary side).
- Power-On Reset pin (primary side).
- Debug mode.
- Internal Pulse Suppressor.
- Fully Programmable Active Clamping Inhibit signal (secondary side).
- Fully programmable Two-Level Turn On (TTON).
- Fully programmable Two-Level Turn Off (TTOFF).
- 8-bit ADC with programmable offset and gain and flexible trigger mechanism.
- Emulated digital channel.
- Programmable Desaturation monitoring.
- Overcurrent protection with programmable threshold.
- Automatic Emergency Turn-Off in failure case.
- Undervoltage supervision of 5V and 15V supplies.
- Programmable UVLO2 and DESAT thresholds for MOSFET usage.
- Safe internal state machine.
- Internal liveness watchdog.
- Weak turn-on.
- NFLTA and NFLTB notification pins for fast system response time (primary side).
- Individual error and status flags readable via SPI.
- Compatible to EiceBoost family.
- 36-pin PG-DSO-36 green package.
- Automotive qualified (as per AEC Q100).

1.3 Target Applications

- Inverters for automotive Hybrid Electric Vehicles (HEV) and Electric Vehicles (EV).
- High Voltage DC/DC converter.
- Industrial Drive.

2 Functional Description

2.1 Introduction

The 1EDI2010AS is an advanced single channel IGBT driver that can also be used for driving power MOS devices. The device has been developed in order to optimize the design of high performance automotive inverters.

The device is based on Infineon's Coreless Transformer Technology and consist of two chips separated by a galvanic isolation. The low voltage (primary) side can be connected to a standard 5 V logic. The high voltage (secondary) side is in the DC-link voltage domain.

Internally, the data transfers are ensured by two independent communication channels. One channel is dedicated to transferring the ON and OFF information of the PWM input signal only. This channel is unidirectional (from primary to secondary). Because this channel is dedicated to the PWM information, latency time and PWM distortion are minimized. The second channel is bidirectional and is used for all the other data transfers (e.g. status information, etc).

The 1EDI2010AS supports advanced functions, such as Two Level Turn-On and Two Level Turn-Off, in order to optimize the switching behavior of the IGBT. Furthermore, it supports several protection functions such as DESAT, Overcurrent protection, etc.

2.2 Pin Configuration and Functionality

2.2.1 Pin Configuration

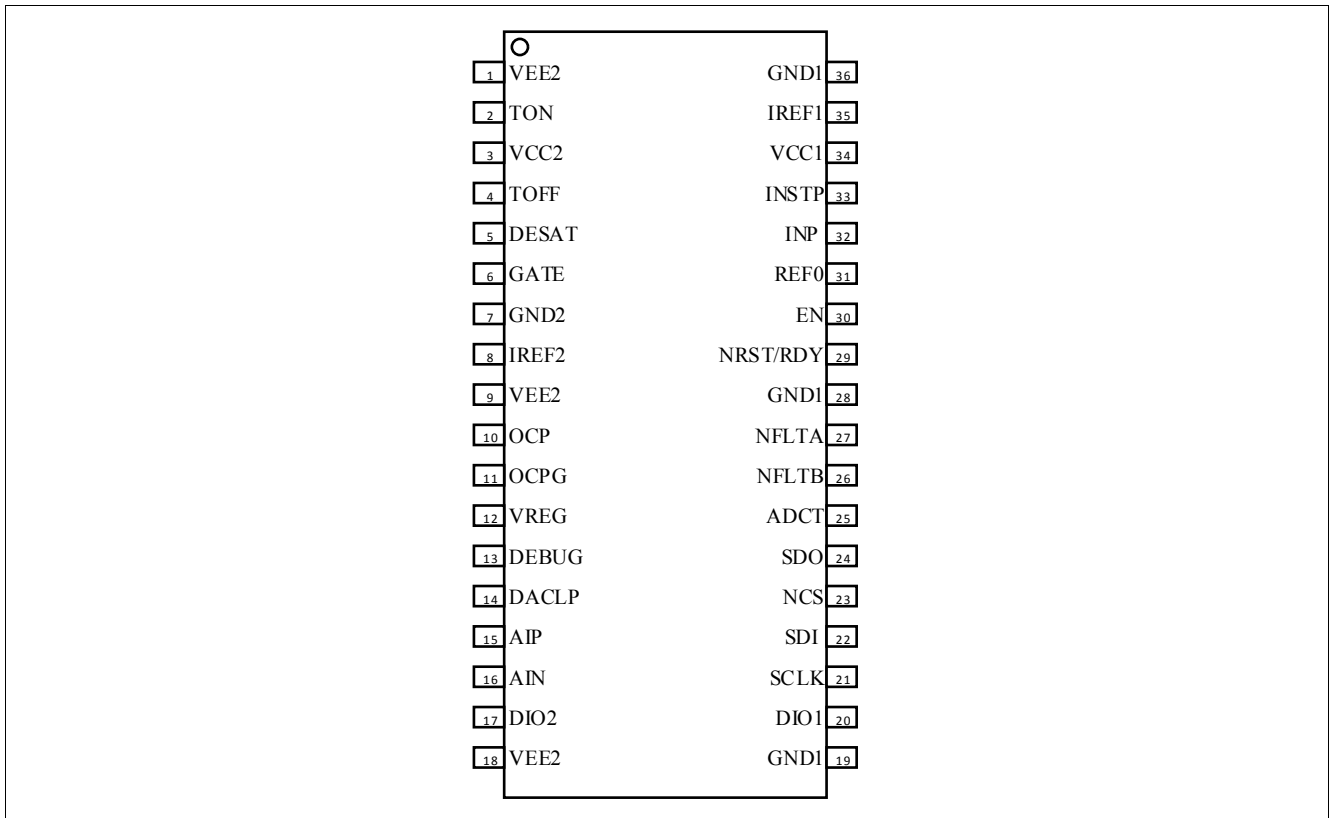

Figure 2-1 EiceSENSE Pin Configuration

Table 2-1 Pin Configuration

Pin Number	Symbol	I/O	Voltage Class	Function
1,9,18	VEE2	Supply	Supply	Negative Power Supply ¹⁾ .
2	TON	Output	15V Secondary	Turn-On Output.
3	VCC2	Supply	Supply	Positive Power Supply.
4	TOFF	Output	15V Secondary	Turn-Off Output.
5	DESAT	Input	15V Secondary	Desaturation Protection Input.
6	GATE	Input	15V Secondary	Gate Monitoring Input.
7	GND2	Ground	Ground	Ground.
8	IREF2	Input	5V Secondary	External Reference Input.
10	OCP	Input	5V Secondary	Over Current Protection.
11	OCPG	Ground	Ground	Ground for the OCP function,
12	VREG	Output	5V Secondary	Reference Output Voltage.
13	DEBUG	Input	5V Secondary	Debug Input.

Table 2-1 Pin Configuration (cont'd)

Pin Number	Symbol	I/O	Voltage Class	Function
14	DACLP	Output	5V Secondary	Active Clamping Disable Output.
15	AIP	Input	5V Analog Secondary	ADC Positive Analog Input
16	AIN	Input	5V Analog Secondary	ADC Negative Analog Input
17	DIO2	Input / Output	5V Secondary	Digital I/O.
19, 28, 36	GND1	Ground	Ground	Ground ²⁾ .
20	DIO1	Input / Output	5V Primary	Digital I/O.
21	SCLK	Input	5V Primary	SPI Serial Clock Input.
22	SDI	Input	5V Primary	SPI Serial Data Input.
23	NCS	Input	5V Primary	SPI Chip Select Input (low active).
24	SDO	Output	5V Primary	SPI Serial Data Output.
25	ADCT	Input	5V Primary	ADC Trigger Input.
26	NFLTB	Output	5V Primary	Fault B Output (low active, open drain).
27	NFLTA	Output	5V Primary	Fault A Output (low active, open drain).
29	NRST/RDY	Input/Output	5V Primary	Reset Input (low active, open drain). This signal notifies that the device is "ready".
30	EN	Input	5V Primary	Enable Input.
31	REF0	Ref. Ground	Ground	Reference Ground for signals INP , INSTP , EN .
32	INP	Input	5V Primary	Positive PWM Input.
33	INSTP	Input	5V Primary	Monitoring PWM Input.
34	VCC1	Supply Input	Supply	Positive Power Supply.
35	IREF1	Input	5V Primary	External Reference Input.

1) All **VEE2** pins must be connected together.

2) All **GND1** pins must be connected together.

2.2.2 Pin Functionality

2.2.2.1 Primary Side

GND1

Ground connection for the primary side.

VCC1

5V power supply for the primary side (referring to GND1).

INP

Non-inverting PWM input of the driver. The internal structure of the pad makes the IC robust against glitches. An internal weak pull-down resistor to V_{REF0} drives this input to Low state in case the pin is floating.

INSTP

Monitoring PWM input for shoot through protection. The internal structure of the pad makes the IC robust against glitches. An internal weak pull-down resistor to V_{REF0} drives this input to Low state in case the pin is floating.

REF0

Reference Ground signal for the signals **INP**, **INSTP**, **EN**. This pin should be connected to the ground signal of the logic issuing those signals.

EN

Enable Input Signal. This signal allows the logic on the primary side to turn-off and deactivate the device. An internal weak pull-down resistor to V_{REF0} drives this input to Low state in case the pin is floating.

NFLTA

Open-Drain Output signal used to report major failure events (Event Class A). In case of an error event, **NFLTA** is driven to Low state. This pin shall be connected externally to V_{CC1} with a pull-up resistance.

NFLTB

Open-Drain Output signal used to report major failure events (Event Class B). In case of an error event, **NFLTB** is driven to Low state. This pin shall be connected externally to V_{CC1} with a pull-up resistance.

SCLK

Serial Clock Input for the SPI interface. An internal weak pull-up device to V_{CC1} drives this input to high state in case the pin is floating.

SDO

Serial Data Output (push-pull) or the SPI interface.

SDI

Serial Data Input for the SPI interface. An internal weak pull-up device to V_{CC1} drives this input to high state in case the pin is floating.

NCS

Chip Select input for the SPI interface. This signal is low active. An internal weak pull-up device to V_{CC1} drives this input to High state in case the pin is floating.

IREF1

Reference input of the primary chip. This pin shall be connected to V_{GND1} via an external resistor.

NRST/RDY

Open drain reset input. This signal is low-active. When a valid signal is received on this pin, the device is brought in its default state. This signal is also used as a “ready notification”. A high level on this pin indicates that the primary chip is functional.

DIO1

I/O for the digital channel. Depending of the chosen configuration of the device, this pin can be an input or an output (push-pull). An internal weak pull-down resistor to V_{GND1} drives this input to Low state in case the pin is floating.

ADCT

ADC Trigger Input. An internal weak pull-down device to V_{GND1} drives this input to Low state in case the pin is floating.

2.2.2.2 Secondary Side**VEE2**

Negative power supply for the secondary side, referring to V_{GND2} .

VCC2

Positive power supply for the secondary side, referring to V_{GND2} .

GND2

Reference ground for the secondary side.

DESAT

Desaturation Protection input pin. The function associated with this pin monitors the V_{CE} voltage of the IGBT. The detection threshold is programmable. An internal pull-up resistor to V_{CC2} drives this signal to High level in case it is floating.

OCP

Over Current Protection input pin. The function associated with this pin monitors the voltage across a sensing resistance located on the auxiliary path of a Current Sense IGBT. An internal weak pull-up resistor to the internal 5V reference drives this input to High state in case the pin is floating.

OCPG

Over Current Protection Ground.

TON

Output pin for turning on the IGBT.

TOFF

Output pin for turning off the IGBT.

GATE

Input pin used to monitor the IGBT gate voltage.

DEBUG

Debug input pin. This pin is latched at power-up. When a High level is detected on this pin, the device enters a special mode where it can be operated without SPI interface. This feature is for development purpose only. This pin should normally be tied to V_{GND2} . An internal weak pull-down resistor to V_{GND2} drives this input to Low state in case the pin is floating.

IREF2

Reference input of the secondary chip. This pin shall be connected to V_{GND2} via an external resistor.

VREG

Reference Output voltage. This pin shall be connected to an external capacitance to V_{GND2} .

DACLP

Output pin used to disable the active clamping function of the booster.

DIO2

I/O for the digital channel. Depending of the chosen configuration of the device, this pin can be an input or an output (push-pull). An internal weak pull-down resistor to V_{GND2} drives this input to Low state in case the pin is floating.

AIP

ADC positive analog input.

AIN

ADC negative analog input.

2.2.2.3 Pull Devices

Some of the pins are connected internally to pull-up or pull-down devices. This is summarized in [Table 2-2](#).

Table 2-2 Internal pull devices

Signal	Device
INP	Weak pull down to V_{REF0}
INSTP	Weak pull down to V_{REF0}
EN	Weak pull down to V_{REF0}
SCLK	Weak pull up to V_{CC1}

Table 2-2 Internal pull devices

Signal	Device
SDI	Weak pull up to V_{CC1}
NCS	Weak pull up to V_{CC1}
ADCT	Weak pull down to V_{GND1}
DIO1	Weak pull down to V_{GND1}
DESAT	Weak pull up to V_{CC2}
DIO2	Weak pull down to V_{GND2}
OCP	Weak pull up to 5V internal reference
DEBUG	Weak pull down to V_{GND2}

2.3 Block Diagram

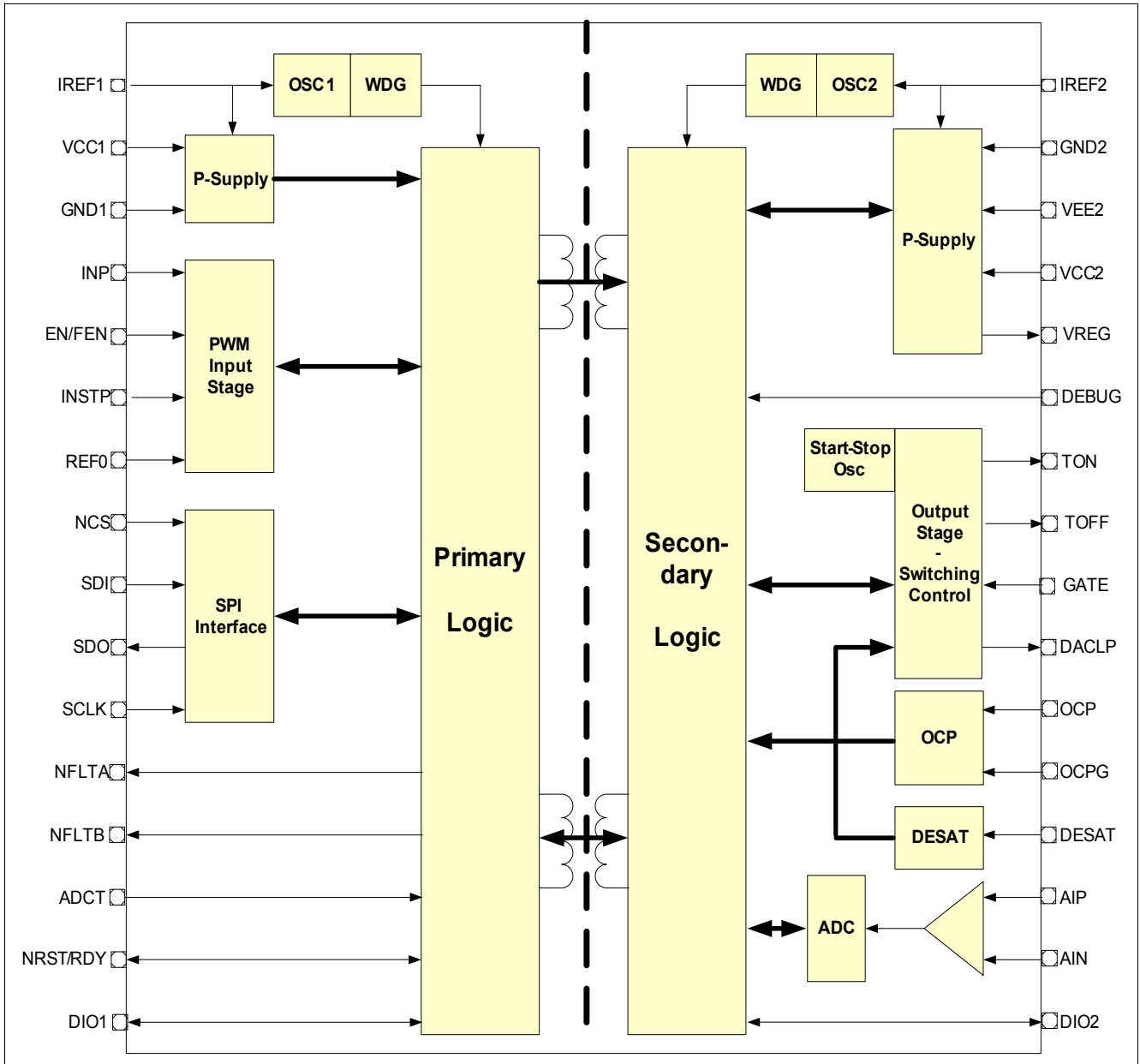

Figure 2-2 Block Diagram

2.4 Functional Block Description

2.4.1 Power Supplies

On the primary side, the 1EDI2010AS needs a single 5 V supply source V_{CC1} for proper operation. This makes the device compatible to most of the microcontrollers available for automotive applications.

On the secondary side, the 1EDI2010AS needs two power supplies for proper operation:

- The positive power supply V_{CC2} is typically set to 15 V (referring to V_{GND2}).
- Optionally, a negative supply V_{EE2} (typically set to -8 V referring to V_{GND2}) can be used. In case a negative supply is not needed, V_{EE2} shall be connected to V_{GND2} .

Undervoltage monitoring on V_{CC1} and V_{CC2} is performed continuously during operation of the device (see [Chapter 3.3.1](#)).

A 5V supply for the digital domain on the secondary side is generated internally (present at pin **VREG**).

2.4.2 Clock Domains

The clock system of the 1EDI2010AS is based on three oscillators defining each a clock domain:

- One RC oscillator (OSC1) for the primary chip.
- One RC oscillator (OSC2) for the secondary chip excepting the output stage.
- One Start-Stop oscillator (SSOSC2) for the output stage on the secondary side.

The two RC oscillators are running constantly. They are also monitored constantly, and large deviations from the nominal frequency are identified as a system failure (Event Class B, see [Chapter 2.4.9.2](#)).

The Start Stop oscillator is controlled by the PWM command.

2.4.3 PWM Input Stage

The PWM input stage generates from the external signals **INP**, **INSTP** and **EN** the turn-on and turn-off commands to the secondary side. The general structure of the PWM input block is shown **Figure 2-3**.

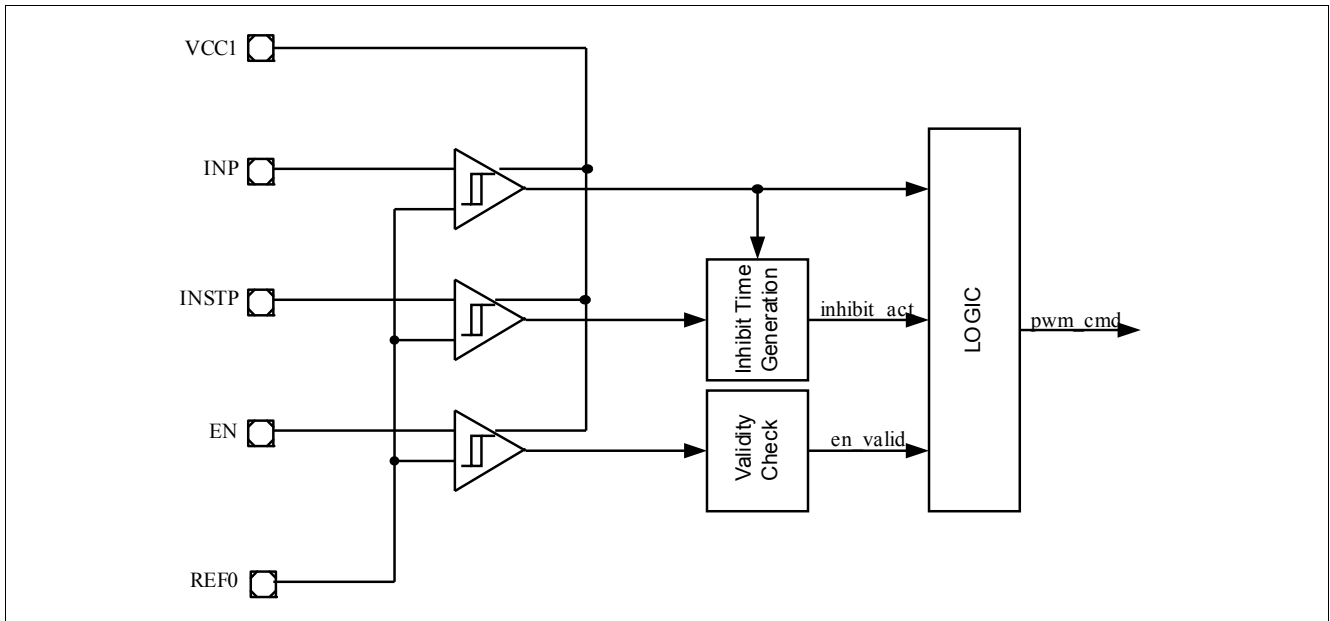

Figure 2-3 PWM Input Stage

Signals **INP**, **INSTP** and **EN** are pseudo-differential, in the sense that they are not referenced to the common ground **GND1** but to signal **REF0**. This is intended to make the device more robust against ground bouncing effects.

*Note: Glitches shorter than t_{INPR1} occurring at signal **INP** are filtered internally.*

*Note: Pulses at **INP** below t_{INPPD} might be distorted or suppressed.*

The 1EDI2010AS supports non-inverted PWM signals only. When a High level on pin **INP** is detected while signals **INSTP** and **EN** are valid, a turn-on command is issued to the secondary chip. A Low level at pin **INP** issues a turn-off command to the secondary chip.

Signal **EN** can inhibit turn-on commands received at pin **INP**. A valid signal **EN** is required in order to have turn-on commands issued to the secondary chip. If an invalid signal is provided, the PWM input stage issues constantly turn-off commands to the secondary chip. The functionality of signal **EN** is detailed in **Chapter 2.4.8**.

*Note: After an invalid-to valid-transition of signal **EN**, a minimum delay of t_{INPEN} should be inserted before turning **INP** on.*

As shown in **Figure 2-4**, signal **INSTP** provides a Shoot-Through Protection (STP) to the system. When signal at pin **INSTP** is at High level, the internal signal `inhibit_act` is activated. The inhibition time is defined as the pulse duration of signal `inhibit_act`. It corresponds to the pulse duration of signal **INSTP** to which a minimum dead time is added. During the inhibition time, rising edges of signal **INP** are inhibited. Bit **PSTAT2.STP** is set for the duration of the inhibition time.

The deadtime is programmable with bit field **PCFG2.STPDEL**.

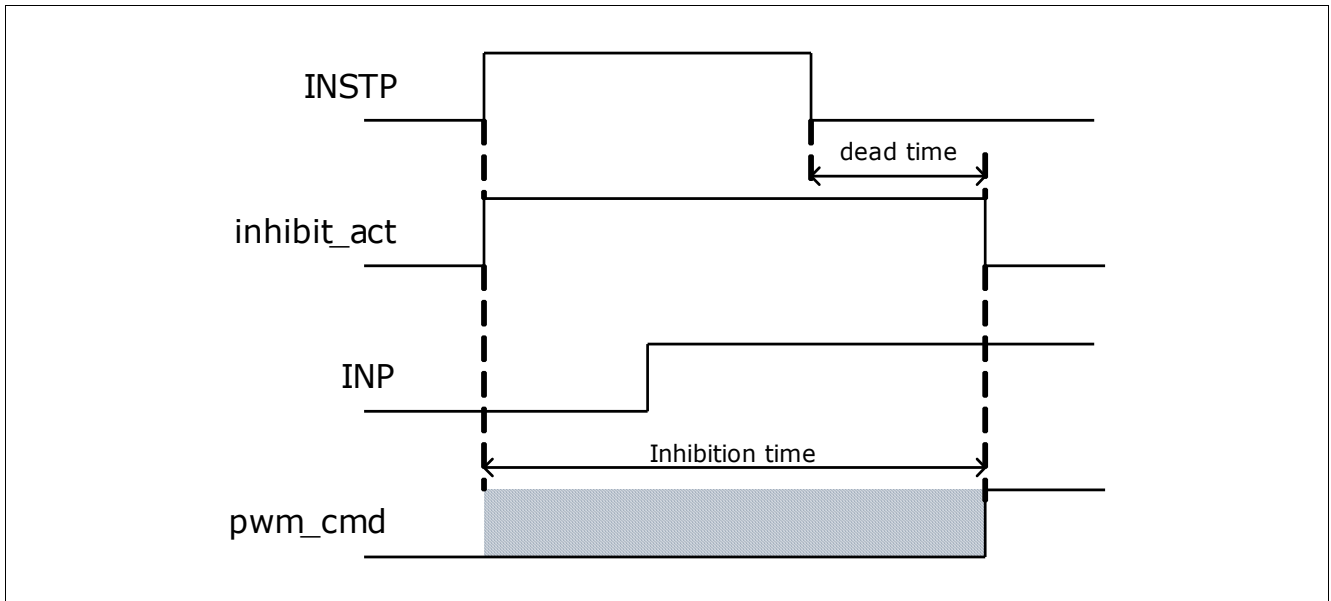

Figure 2-4 STP: Inhibition Time Definition

It shall be noted that during the inhibition time, signal `pwm_cmd` is not forced to Low. It means that if the device is already turned-on when `INSTP` is High, it stays turned-on until the signal at pin `INP` goes Low. This is depicted in [Figure 2-5](#).

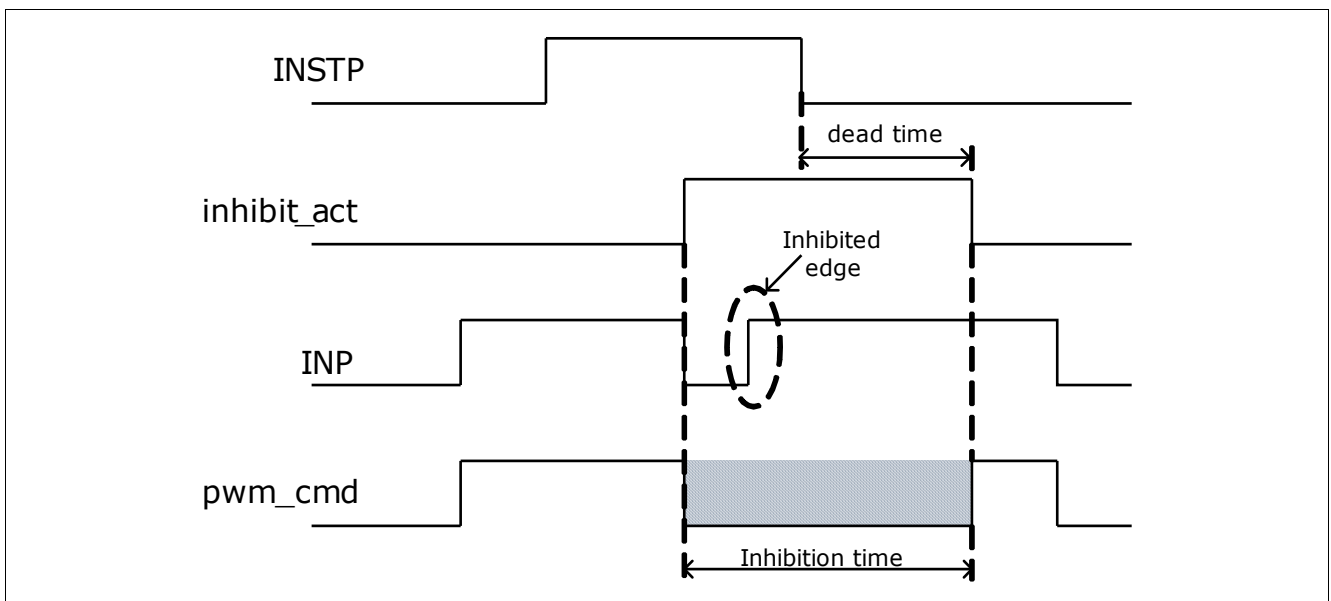

Figure 2-5 STP: Example of Operation

When a condition occurs where a rising edge of signal `INP` is inhibited, an error notification is issued. See [Chapter 3.4.1](#) for more details.

Note: The failure notification via bit `PER.STPER` is filtered internally for timings shorter than 1 `OSC1` clock cycle. There will be no notification but may lead to a delay of signal `INP`.

2.4.4 SPI Interface

This chapter describes the functionality of the SPI block.

2.4.4.1 Overview

The standard SPI interface implemented on the 1EDI2010AS is compatible with most of the microcontrollers available for automotive and industrial applications. The following features are supported by the SPI interface:

- Full-duplex bidirectional communication link.
- SPI Slave mode (only).
- 16-bit frame format.
- Daisy chain capability.
- MSB first.
- Parity Check (optional) and Parity Bit generation (LSB).

The SPI interface of the 1EDI2010AS provides a standardized bidirectional communication interface to the main microcontroller. From the architectural point of view, it fulfills the following functions:

- Initialization of the device.
- Configuration of the device (static and runtime).
- Reading of the status of the device (static and runtime).
- Operation of the verification modes of the device.

The purpose of the SPI interface is to exchange data which have relaxed timing constraints compared to the PWM signals (from the point of view of the motor control algorithm). The IGBT switching behavior is for example controlled directly by the PWM input. Similarly, critical application failures requiring fast reaction are notified on the primary side via the feedback signals **NFLTA**, **NFLTb** and **NRST/RDY**.

In order to minimize the complexity of the end-application and to optimize the microcontroller's resources, the implemented interface has daisy chain capability. Several (typically 6) 1EDI2010AS devices can be combined into a single SPI bus.

2.4.4.2 General Operation

The SPI interface of the 1EDI2010AS supports full duplex operation. The interface relies on four communication signals:

- **NCS:** (Not) Chip Select.
- **SCLK:** Serial Clock.
- **SDI:** Serial Data In.
- **SDO:** Serial Data Out.

The SPI interface of the 1EDI2010AS supports slave operation only. An SPI master (typically, the main microcontroller) is connected to one or several 1EDI2010AS devices, forming an SPI bus. Several bus topologies are supported.

A regular SPI bus topology can be used where each of the slaves is controlled by an individual chip select signal ([Figure 2-6](#)). In this case, the number of slaves on the bus is only limited by the application's constraints.

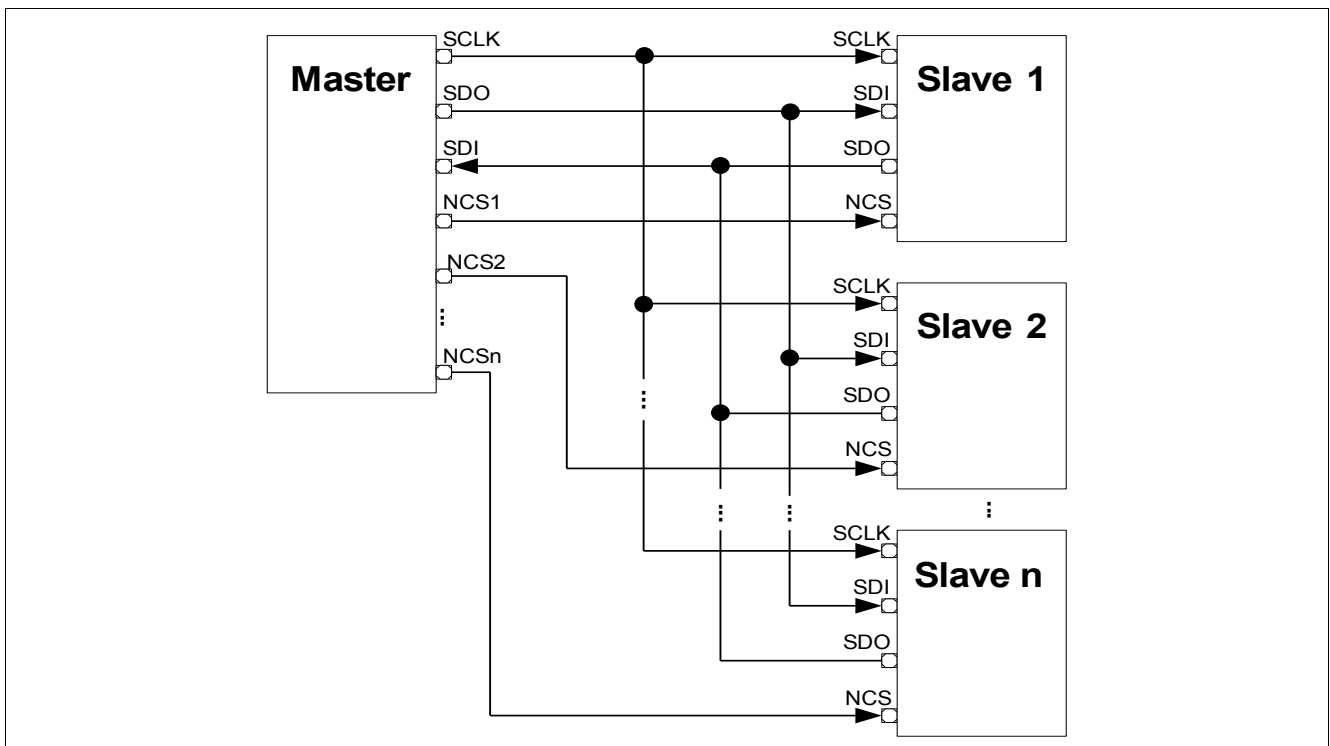

Figure 2-6 SPI Regular Bus Topology

In order to simplify the layout of the PCB and to reduce the number of pins used on the microcontroller's side, a daisy chain topology can also be used. The chain's depth is not limited by the 1EDI2010AS itself. A possible topology is shown [Figure 2-7](#).

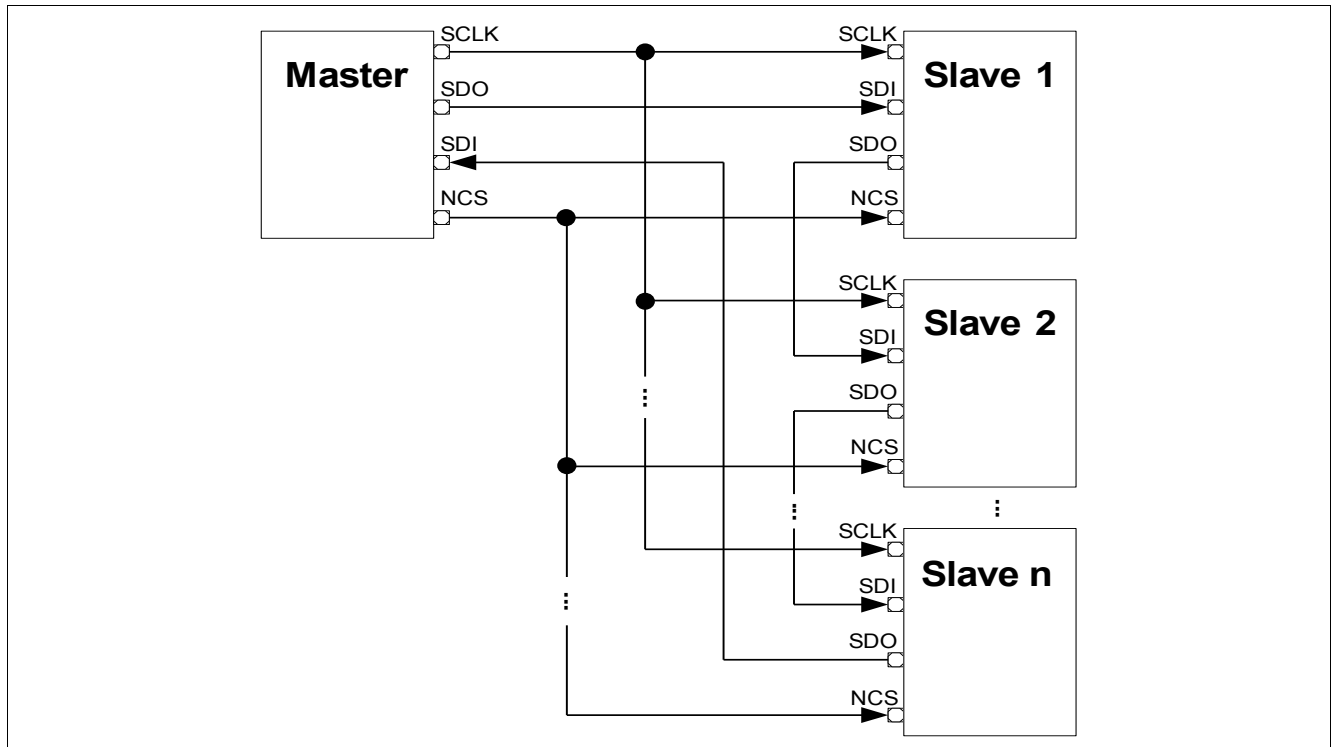

Figure 2-7 SPI Daisy Chain Bus Topology

Physical Layer

The SPI interface relies on two shift registers:

- A shift output register, reacting on the rising edges of **SCLK**.
- A shift input register, reacting on the falling edges of **SCLK**.

When signal **NCS** is inactive, the signals at pins **SCLK** and **SDI** are ignored. The output **SDO** is in tristate.

When **NCS** is activated, the shift output register is updated internally with the value requested by the previous SPI access.

At each rising edge of the **SCLK** signal (while **NCS** is active), the shift output register is serially shifted out by one bit on the **SDO** pin (MSB first). At each falling edge of the clock pulse, the data bit available at the input **SDI** is latched and serially shifted into the shift input register.

At the deactivation of **NCS**, the SPI logic checks how many rising and falling edges of the **SCLK** signal have been received. In case both counts differ and / or are not a multiple of 16, an SPI Error is generated. The SPI block then checks the validity of the received 16-bit word. In case of a non valid data, an SPI error is generated. In case no error is detected, the data is decoded by the internal logic.

The **NCS** signal is active low.

Input Debouncing Filters

The input stages of signals **SDI**, **SCLK**, and **NCS** include each a Debouncing Filter. The input signals are that way filtered from glitches and noise.

The input signals **SDI** and **SCLK** are analyzed at each edge of the internal clock derived from OSC1. If the same external signal value is sampled three times consecutively, the signal is considered as valid and is processed by the SPI logic. Otherwise, the transition is considered as a glitch and is discarded.

The input signal **NCS** is sampled at a rate corresponding to the period of the internal clock derived from OSC1. If the same external signal value is sampled two times consecutively, the signal is considered as valid and is processed by the SPI logic. Otherwise, the transition is considered as a glitch and is discarded.

2.4.4.3 Definitions

Command

A command is a high-level command issued by the SPI master which aims at generating a specific reaction in the addressed slave. The command is physically translated into a Request Message by the SPI master. The correct reception of the Request Message by the SPI slave leads to a specific action inside the slave and to the emission of an Answer Message by the slave.

Example: the READ command leads to the transfer of the value of the specified register from the device to the SPI master.

Word

A word is a 16-bit sequence of shifted data bits.

Transfer

A transfer is defined as the SPI data transfers (in both directions) occurring between a falling edge of **NCS** and the next consecutive rising edge of **NCS**.

Request Message

A request message is a word issued by the SPI master and addressing a single slave. A request message relates to a specific command.

Answer Message

An answer message is a well-defined word issued by a single SPI slave as a response to a request message.

Transmit Frame

A transmit frame is a sequence of one or several words sent by the SPI Master within one SPI transfer. In regular SPI topologies, a transmit frame is in practice identical to a data word. In daisy chain topologies, a transmit frame is a sequence of data words belonging to different request messages.

Receive Frame

A receive frame is a sequence of one or several words received by the SPI Master within one SPI transfer. In regular SPI topologies, a receive frame is in practice identical to a data word. In daisy chain topologies, a receive frame is a sequence of data words belonging to different Answer Messages.

The SPI protocol supported by the 1EDI2010AS is based on the Request / Answer principle. The master sends a defined request message to which the slave answers with the corresponding answer message (**Figure 2-8, Figure 2-9**). Due to the nature of the SPI interface, the Answer Message is shifted, compared to the Request Message, by one SPI transfer. It means, for example, that the last word of answer message n is transmitted by the slave while the master sends the first word of request message $n+1$.

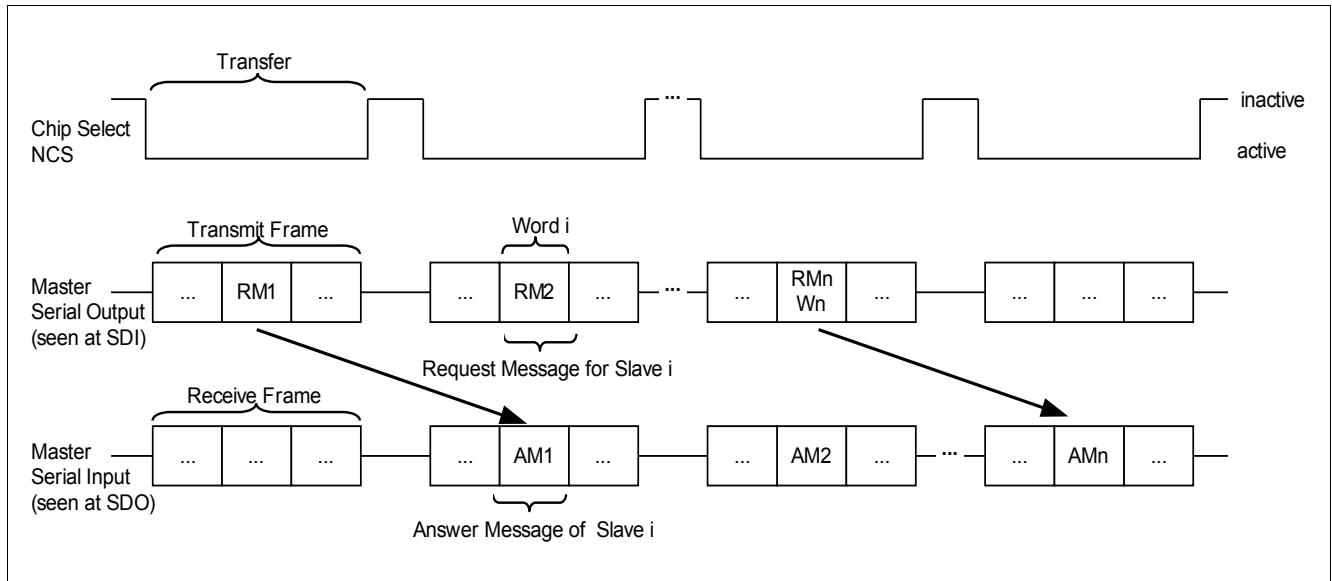

Figure 2-8 Response Answer Principle - Daisy Chain Topology

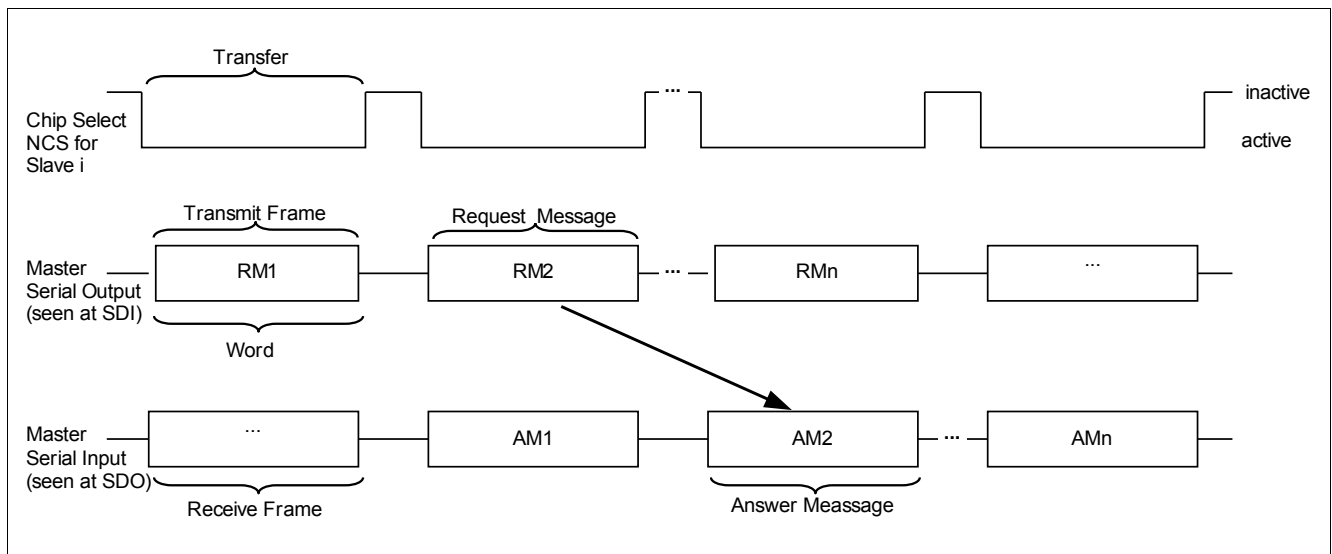

Figure 2-9 Response Answer Principle - Regular Topology

The first word transmitted by the device after power-up is the content of register **PSTAT**.

2.4.4.4 SPI Data Integrity Support

2.4.4.4.1 Parity Bit

By default, the SPI link relies on an odd parity protection scheme for each transmitted or received 16-bit word of the SPI message. The parity bit corresponds to the LSB of the 16-bit word. Therefore, the effective payload of a 16-bit word is 15 data bit (plus one parity bit). The parity bit check (on the received data) can be disabled by clearing bit **PCFG.PAREN**. In this case, the parity bit is considered as “don’t care”. The generation of the parity bit by the driver for transmitted words can not be disabled (but can be considered as “don’t care” by the SPI master).

Note: For fixed value commands (ENTER_CMODE, ENTER_VMODE, EXIT_CMODE, NOP), it has to be ensured that the value of the parity bit is correct even if parity check is disabled. Otherwise, an SPI error will be generated.

2.4.4.4.2 SPI Error

When the device is not able to process an incoming request message, an SPI error is generated: the received message is discarded by the driver, bit **PER.SPIER** is set and the erroneous message is answered with an error notification (bit **LMI** set).

Several failures generate an SPI error:

- A parity error is detected on the received word.
- An invalid data word format is received (e.g. not a 16 bit word).
- A word is received, which does not corresponding to a valid Request Message.
- A command is received which can not be processed. For example, the driver receives in Active Mode a command which is only valid in other operating modes. Another typical example is a read access to the secondary while the previous read access is not yet completed (device “busy”).
- An SPI access to an invalid address.

2.4.4.5 Protocol Description

2.4.4.5.1 Command Catalog

Table 2-3 gives an overview of the command catalog supported by the device. The full description of the commands and of the corresponding request and answer messages is provided in the following sections.

Table 2-3 SPI Command Catalog

Acronym	Short Description	Valid in Mode
ENTER_CMODE	Enters into Configuration Mode.	OPM0, OPM1
ENTER_VMODE	Enters into Verification Mode.	OPM2
EXIT_CMODE	Leaves Configuration Mode to enter into Configured Mode.	OPM2
READ	Reads the register value at the specified address.	All
NOP	Triggers no action in the device (equivalent to a “nop”).	All
WRITEH	Update the most significant byte of the internal write buffer.	All
WRITEL	Updates the least significant byte of the internal write buffer, and copies the contents of the complete buffer into the addressed register. The write buffer is cleared afterwards.	All (with restrictions)

An overview of the commands is given **Figure 2-10**.

Message	Command				Data												P	
ENTER_CMODE	0	0	0	1	1	0	0	0	1	0	0	0	0	0	0	0	0	0
ENTER_VMODE	0	0	0	1	0	0	0	1	0	1	0	0	0	0	0	0	0	0
EXIT_CMODE	0	0	0	1	0	0	1	0	0	0	1	0	0	0	0	0	0	0
NOP	0	0	0	1	0	1	0	0	0	0	0	1	0	0	0	0	0	0
READ	0	0	0	0	A4	A3	A2	A1	A0	0	1	0	1	0	1	0	X	X
WRITEH	0	1	0	0	0	1	0	D15	D14	D13	D12	D11	D10	D9	D8	0	X	X
WRITEL	1	0	1	0	A4	A3	A2	A1	A0	D7	D6	D5	D4	D3	D2	0	X	X

Figure 2-10 SPI Commands Overview

2.4.4.5.2 Word Convention

In order to simplify the description of the SPI commands, the following conventions are used (**Table 2-4**).

Table 2-4 Word Convention

Acronym	Value
Va(REGISTER)	Value of register REGISTER
P _B	Parity Bit

Table 2-4 Word Convention (cont'd)

Acronym	Value
<<n	Left shift operation of n bits.
x _H y _H	Result of the operation: x _H OR y _H

2.4.4.5.3 ENTER_CMODE Command

The goal of this function is to set the device into Configuration Mode. After reception of a valid ENTER_CMODE command, mode OPM2 is active. This command is only valid in Default Mode (OPM0 and OPM1). In case the request message is received while OPM1 is not active, the complete command is discarded and an SPI error occurs.

Table 2-5 describes the request message and the corresponding answer message.

Table 2-5 ENTER_CMODE request and answer messages

	Transfer 1	Transfer 2
Request message	1880 _H	N.a.
Answer message	N.a.	Va(PSTAT)

2.4.4.5.4 ENTER_VMODE Command

The goal of this function is to set the device into Verification Mode. After reception of a valid ENTER_VMODE command, mode OPM5 is active. This command is only valid in Configuration Mode (OPM2). In case the request message is received while OPM2 is not active, the complete command is discarded and an SPI error occurs.

Table 2-6 describes the request message and the corresponding answer message.

Table 2-6 ENTER_VMODE request and answer messages

	Transfer 1	Transfer 2
Request message	1140 _H	N.a.
Answer message	N.a.	Va(PSTAT)

2.4.4.5.5 EXIT_CMODE Command

When a valid EXIT_CMODE is received by the device, the Configuration Mode is left to Configured Mode (Mode OPM3 active). This command is only valid in Configuration Mode (OPM2). In case the request message is received while OPM2 is not active, the complete command is discarded and an SPI error occurs.

Table 2-7 describes the request message and the corresponding answer message.

Table 2-7 EXIT_CMODE request and answer messages

	Transfer 1	Transfer 2
Request message	1220 _H	N.a.
Answer message	N.a.	Va(PSTAT)

2.4.4.5.6 NOP Command

This command triggers no specific action in the driver (equivalent to a “nop”). However, the mechanisms verifying the validity of the word are active. This command is valid in all operating modes.

[Table 2-8](#) describes the request message and the corresponding answer message.

Table 2-8 NOP request and answer messages

	Transfer 1	Transfer 2
Request message	1410 _H	N.a.
Answer message	N.a.	Va(PSTAT)

2.4.4.5.7 READ Command

This command aims at reading the value of the register whose address is specified in the request message. This command is valid in all operating modes. However, in OPM4 and OPM6, the use of the READ command is restricted (see [Table 4-4](#)). If an access outside the allowed address range is performed, the access is discarded as invalid and an SPI error occurs.

[Table 2-9](#) describes the request message and the corresponding answer message.

Table 2-9 READ request and answer messages

	Transfer 1	Transfer 2
Request message	See below	N.a.
Answer message	N.a.	Va(Register)

Request message words

Word 1: (ADDRESS_5BIT << 7) | 002A_H | P_B.

Answer message words

Word 1: Value of REGISTER.

2.4.4.5.8 WRITEH

This command aims at writing the upper byte of the internal write buffer with the specified value. This command has no other effect on the functionality of the device. This command is valid in all operating modes.

[Table 2-10](#) describes the request message and the corresponding answer message.

Table 2-10 WRITEH request and answer messages

	Transfer 1	Transfer 2
Request message	See below	N.a.
Answer message	N.a.	Va(PSTAT)

Request message words

Word 1: 4400_H | (DATA_8BIT << 1) | P_B

2.4.4.5.9 WRITEL

This command aims at updating the value of the register whose address is specified in the request message. This command is valid in all operating modes. However, depending on the active operating mode, this command is restricted to a given address range or specific registers (see [Table 4-5](#)). If an access outside the allowed address range is performed, the access is discarded as invalid and an SPI error occurs.

At the reception of this command, the least significant byte of the internal buffer is written with the specified value, the contents of the buffer is copied to the register at the specified address and the complete write buffer is cleared.

[Table 2-11](#) describes the request message and the corresponding answer message.

Table 2-11 WRITEL request and answer messages

	Transfer 1	Transfer 2
Request message	See below	N.a.
Answer message	N.a.	Va(PSTAT)

Request message words

Word 1: $A000_H | (ADDRESS_5BIT \ll 7) | (DATA_6BIT \ll 1) | P_B$.

2.4.5 Operating Modes

2.4.5.1 General Operation

At any time, the driver can be in one out of seven possible operating modes:

- OPM0: Default Mode (default after reset, device is disabled).
- OPM1: Error Mode (reached after Event Class B, device is disabled).
- OPM2: Configuration Mode (device is disabled, configuration of the device can be modified).
- OPM3: Configured Mode (device is configured and disabled).
- OPM4: Active Mode (normal operation).
- OPM5: Verification mode (intrusive diagnostic functions can be triggered).
- OPM6: Weak active mode (the device can be turned on but with restrictions)

The current active mode of the device is given by bit field **SSTAT.OPMS**.

The concept of the device is based on the following general ideas:

- The driver can only switch the IGBT on when OPM4 mode is active (exception: weak-turn on in OPM6).
- Starting from Mode OPM0 or OPM1, the Active Mode OPM4 can only be activated through a dedicated SPI command sequence and the activation of the hardware signal **EN**. As a result, the probability that the device goes to OPM4 mode due to random signals is negligible.
- Differentiations of errors: different classes of errors are defined, leading to different behavior of the device.

The state diagram for the operating modes is given in **Figure 2-11**:

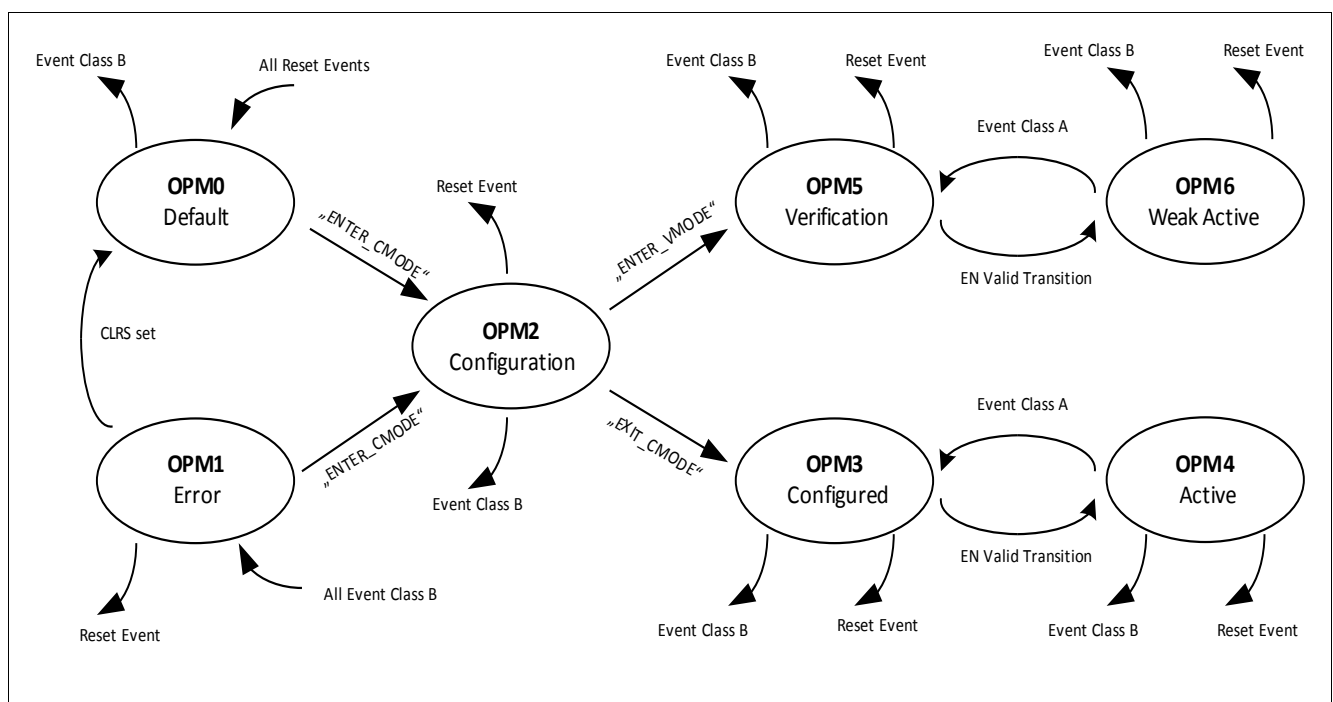

Figure 2-11 Operating Modes State Diagram

2.4.5.2 Definitions

2.4.5.2.1 Events and State Transitions

The transitions from one state to the other are based on “events” and / or SPI commands. The following classification is chosen for defining the events.

Events Class A

The following (exhaustive) list of events are defined as Events Class A:

- Occurrence of a DESAT event (leads to a safe turn-off sequence).
- Occurrence of an OCP event (leads to a safe turn-off sequence).
- Valid to Invalid transition on **EN** signal (leads to a regular turn-off sequence).
- ADC Boundary Check Violation Event (optional, can be disabled).

When an Event Class A occurs, the output stage either initiates either a safe turn-off sequence (DESAT, OCP) or a regular turn-off sequence (all other events). The event is notified via an error bit in the corresponding register.

Note: Contrarily to a reset event, an Event Class A does not affect the contents of the configuration registers.

When an Event Class A occurs, the device may change its operating mode depending on which mode is active when the event occurs:

- If it was in OPM4, it goes in OPM3.
- If it was in OPM6, it goes in OPM5.

In all other cases, the OPM is unaffected. A state transition due to an Event Class A leads to the activation of signal **NFLTA**. If no state transition occurs (if for example the device was not in OPM4 or OPM6), **NFLTA** is not activated (exception: ADC Boundary Check event - see [Chapter 2.4.7](#) for more details on failure notifications).

Events Class B

The following (exhaustive) list of events are defined as Events Class B:

- Occurrence of a UVLO2 event.
- Verification Mode Time Out Error

When an Event Class B occurs, the output stage initiates a regular turn-off sequence. The event is notified via an error bit in the corresponding register and (possibly) via the signal **NFLTB**.

Note: Events Class B may affect the contents of the configuration registers.

When an Event Class B occurs, the device may change its operating mode depending on which mode is active when the event occurs: if it was not in OPM1, it goes to OPM1. It is unaffected otherwise

A state transition due to an Event Class B leads to the activation of signal **NFLTB**. If no state transition occurs (if for example the device was already in OPM1), **NFLTB** is not activated. See [Chapter 2.4.7](#) for more details on failure notifications.

Events Class C

Generally speaking, Events Class C are error events that do not lead to a change of the operating mode of the device. The following (non-exhaustive) list of events is comprised within the Event Class C:

- SPI Error.
- Shoot Through Protection error.
- Etc.

SPI Commands

The following SPI commands have an impact on the device's operating mode. The SPI commands are described in [Chapter 2.4.4.5](#).

- ENTER_CMODE.
- ENTER_VMODE.
- EXIT_CMODE.
- Setting of bit **SCTRL.CLRS** (by writing register **PCTRL**)

Reset Events

A reset sets the device (or part of the device) in its default state. Reset events are described in [Chapter 2.4.10](#). Internal Supervision Error are leading to a reset event, for example.

2.4.5.2.2 Emergency Turn-Off Sequence

The denomination "Emergency Turn-Off Sequence" (ETO) is used to describe the sequence of actions executed by the output stage of the device when an Event Class A, Class B or a Reset Event is detected.

An ETO sequence is described by the following set of actions:

- A Turn-Off sequence is initiated. In case of DESAT or OCP event, a safe turn-off sequence is initiated. For the other events, a regular turn-off sequence is initiated.
- The device enters the corresponding OPM mode. As a consequence, the device is disabled.

Once an ETO has been initiated, the device can not be reenabled for a maximum duration consisting of 256 OSC2 clock cycles. Consequently, the user shall wait for this duration before reenabling the device and sending PWM turn-on command.

2.4.5.2.3 Ready, Disabled, Enabled and Active State

The device is said to be in Ready state in case no reset event is active on the primary chip. When the device is Ready, signal **NRST/RDY** is at High level.

When the device is in Disabled State, the PWM turn-on commands are ignored. This means that whatever the input signal **INP** is, the output stage (if not tristated) delivers a constant turn-off signal to the IGBT. Unless otherwise stated, all other functions of the device work normally.

When the device is not in Disabled State, it is said to be in Enabled State. In this case, the PWM signal command is processed normally (if the output stage is not tristated). Practically, the device is in Enabled State when either Mode OPM4 or Mode OPM6 is active.

Active State corresponds to the normal operating state of the device. Practically, the device is in Active State when Mode OPM4 is active.

Note: When the device is in Active State, it implicates it is in Enabled state.

2.4.5.3 Operation Modes Description

Default Mode (OPM0)

Mode OPM0 is the default operating mode of the device after power up or after a rest event. In OPM0, the device is in Disabled State.

The following exhaustive list of events bring the device in OPM0 Mode:

- Occurrence of a Reset Event.
- Bit **SCTRL.CLRS** set while the device was in OPM1.

Error Mode (OPM1)

Mode OPM1 is the operating mode of the device after an Event Class B.

The following exhaustive list of events bring the device in OPM1 Mode:

- Occurrence of an Event Class B.

In OPM1, when bit **SCTRL.CLRS** is set via the corresponding SPI command, the device shall normally jump to OPM0. However, in case the conditions for an Event Class B are met at that moment, no state transition occurs and the device stays in OPM1. The operation of bit **SCTRL.CLRS** on the secondary sticky bits works normally.

In OPM1, when a valid ENTER_CMODE command is received, the device shall normally jump to OPM2. However, in case the conditions for an Event Class B are met at that moment, no state transition occurs and the device stays in OPM1 for the duration of the event. The state transition to OPM2 is executed as soon as the conditions leading to the Event Class B disappear. It shall be noted that no LMI error notification is issued.

Configuration Mode (OPM2)

Configuration Mode is the mode where the configuration of the device can be modified. When OPM2 is active, the device is in Disabled State.

The following exhaustive list of events bring the device in Configuration Mode:

- Reception of a valid ENTER_CMODE command **while** Mode OPM0 or OPM1 active.

Configured Mode (OPM3)

Configured Mode is the mode where the device is ready to be enabled. When OPM3 is active, the device is in Disabled State.

The following exhaustive list of events bring the device in Mode OPM3:

- Reception of a valid EXIT_CMODE command **while** Mode OPM2 active.
- Event Class A **while** Mode OPM4 active.

Active Mode (OPM4)

The Active Mode corresponds to the normal operating mode of the device. When OPM4 is active, the device is in Active State. The following exhaustive list of event bring the device in Active Mode:

- Invalid to Valid Transition on signal **EN** **while** Mode OPM3 active.

Verification Mode (OPM5)

Verification Mode is the mode where intrusive verification functions can be started. When OPM5 is active, the device is in disabled state.

The following exhaustive list of event bring the device in Verification Mode:

- Reception of a valid ENTER_VMODE command **while** Mode OPM2 active.
- Occurrence of an Event Class A **while** Mode OPM6 active.

After a transition from Mode OPM2 to OPM5, an internal watchdog timer is started. If after time t_{VMTO} , the device has not left both modes OPM5 or OPM6, a time-out event occurs and an Event Class B is generated.

Weak Active Mode (OPM6)

Weak Active Mode is the mode where the device can be activated to run diagnosis tests at system level. When OPM6 is active, the device is in Enabled State. A PWM turn-on command issues a Weak Turn-On on the secondary side.

The following exhaustive list of event bring the device in Weak Active Mode:

- Invalid to Valid Transition on signal **EN** **while** Mode OPM5 active.

The watchdog counter started when entering Mode OPM5 is not reset when entering OPM6.

Implementation Notes related to State Transitions

- An Event Class A or Class B detected on the secondary side lead to an immediate reaction of the device's output stage. Due to the latency of the inter-chip communication, the notification on the primary side is slightly delayed.
- The activation of signal **NFLTA** or **NFLTB** is simultaneous to the corresponding state transition on the primary side.
- It is possible to change the operating mode while a failure condition is present. This may however lead to a new immediate error notification and state transition.

2.4.5.4 Activating the device after reset

After a reset event, the device is in Mode OPM0 and disabled. In order to be active, the device needs to enter Configuration Mode with the ENTER_CMODE command. Once all the configurations have been performed, the Configuration Mode has to be exited with an EXIT_CMODE command. Once this is done, the device can enter the Active Mode when Invalid to Valid transition on pin **EN** is detected.

2.4.5.5 Activating the device after an Event Class A or B

If during operation, an Event Class A occurs, the device enters the OPM3 (or OPM5). Bit field **SSTAT.OPMS** is updated accordingly. In order to reactivate the device, an invalid-to-valid transition has to be applied to signal **EN**. It means for example in EN Mode, that a Low-level and then a High level is applied to **EN**. If no Event Class A event is active, the device will enter OPM4 (respectively OPM6).

If during operation, an Event Class B occurs, the device enters the Default Mode OPM1. Bit field **SSTAT.OPMS** is updated accordingly. In order to reactivate the device, the steps defined in [Chapter 2.4.5.4](#) need to be performed.

2.4.5.6 Debug Mode

The **DEBUG** pin gives the possibility to operate the device in the so-called Debug Mode. The goal of the Debug Mode is to operate the device without SPI interface. This mode should be used for development purpose only and is not intended to be used in final applications.

At V_{CC2} power-on, the level at pin **DEBUG** is latched. In case a High level is detected, the device enters the Debug Mode. Bit **SSTAT.DBG** is then set.

In Debug Mode, the regular operation of the internal state machine is modified, so that the device can only enter OPM3 or OPM4. As a result Modes OPM0, OPM1, OPM2, OPM5 and OPM6 are completely bypassed. In case of a Reset event, the device goes to OPM3 (instead of OPM0). Besides, in Debug Mode, events leading normally to an Event Class B are replaced an Event Class A, resulting in the activation of signal **NFLTA**. Event Class B are therefore not generated by the device in Debug Mode (and signal **NFLT B** shall not be used).

It should be noted that the configuration of the device in Debug Mode corresponds to the default settings and can not be changed.

In Debug Mode, the operation of the device is otherwise similar to regular operation. It means in particular that the signal **EN** has to be managed properly: when the device is in OPM3, a Low to High level transition has to be applied to the device in order to enter OPM4 (Active Mode).

*Note: Once it has been latched at power-on, the level on the pin **DEBUG** has no impact on the device until the next power-on event on the secondary side.*

2.4.6 Driver Functionality

The structure of the output stage and its associated external booster of the device is depicted [Figure 2-12](#):

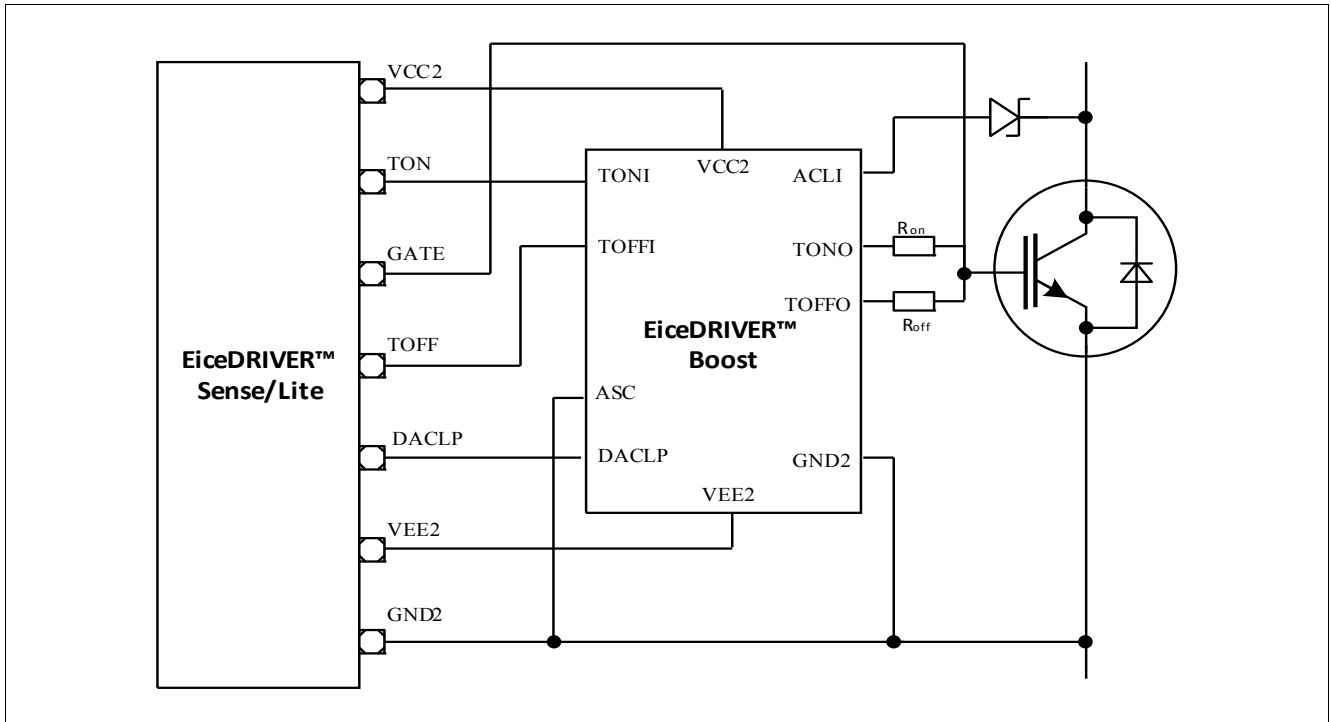

Figure 2-12 Output Stage Diagram of Principle

2.4.6.1 Overview

Two turn-off behaviors are supported by the device, depending on the event causing the turn-off action.

- Regular Turn-Off.
- Safe Turn-Off.

A Safe Turn-Off sequence uses the timing and plateau level parameters defined in register [SSTOF](#). It is triggered by a DESAT or an OCP event only. A turn-off sequence which is not “Safe” is then “Regular”. A Regular Turn-Off sequence uses the timing parameters defined in register [SRTTOF](#) and the plateau level defined by [PCTRL2.GPOF](#).

Two Level Turn-Off (TTOFF)

Because a hard turn-off may generate a critical overvoltage on the IGBT leading eventually to its destruction, the 1EDI2010AS supports the Two Level Turn-Off functionality (TTOFF). The TTOFF function consists in switching the IGBT off in three steps in such a way that:

1. The IGBT gate voltage is first decreased with a reduced slew rate until a specific (and programmable) voltage is reached by the [TOFF](#) signal.
2. [TOFF](#) (and [TON](#)) voltage is stabilized at this level. The IGBT Gate voltage forms thus a plateau.
3. Finally, the switch-off sequence is resumed using hard commutation.

The TTOFF delays and plateau voltage are fully programmable using the corresponding SPI commands. For a Regular Turn-Off sequence, the TTOFF delay is defined by bit field [SRTTOF.RTVAL](#). Setting this field to 00_H completely disables the TTOFF function for all Regular Turn-Off sequences (but this has no effect on Safe Turn-Off sequences). The plateau level is defined by [PCTRL2.GPOF](#). If this function is to be activated, a minimum value

for the delay time has to be programmed. Too small delays will not be visible as plateau on the output signal, may changes just the slew rate from V_{CC2} to plateau.

For a Safe Turn-Off sequence, the TTOFF delay is defined by bit field **SSTOF.STVAL**. Setting this field to 00_H completely disables the TTOFF function for all Safe Turn-Off sequences (but this has no effect on Regular Turn-Off sequences). If this function is to be activated, a minimum value for the delay time has to be programmed. The plateau level is defined by **SSTOF.GPS**.

The timing of a Safe Turn-Off event is in the clock domain of the main secondary oscillator (OSC2). The timing of a Regular Turn-Off event is in the clock domain of the Start-Stop Oscillator (SSOSC2), leading to high accuracy and low PWM distortion

When using the TTOFF function (with a non-zero delay), the PWM command is received on pin **INP** is delayed by the programmed delay time (**Figure 2-13**). For pulses larger than the TTOFF delay ($t_{PULSE} > t_{TTOFF} + \text{two SSOSC cycles}$), the output pulse width is kept identical to the input pulse width. For smaller pulses ($t_{PULSE} < t_{TTOFF} + 2$ two SSOSC cycles), the output pulse is identical to the programmed delay. The minimum pulse width delivered by the device to the IGBT is therefore the programmed delay time extended by two SSOSC cycles.

The device allows for external booster voltage compensation at the IGBT gate. When bit **SCFG.VBEC** is cleared, the voltage at **TOFF** at the plateau corresponds to the programmed value. When bit **SCFG.VBEC** is set, an additional V_{BE} (base emitter junction voltage of an internal pn diode) is subtracted to the programmed voltage at **TOFF** in order to compensate for the V_{BE} of an external booster.

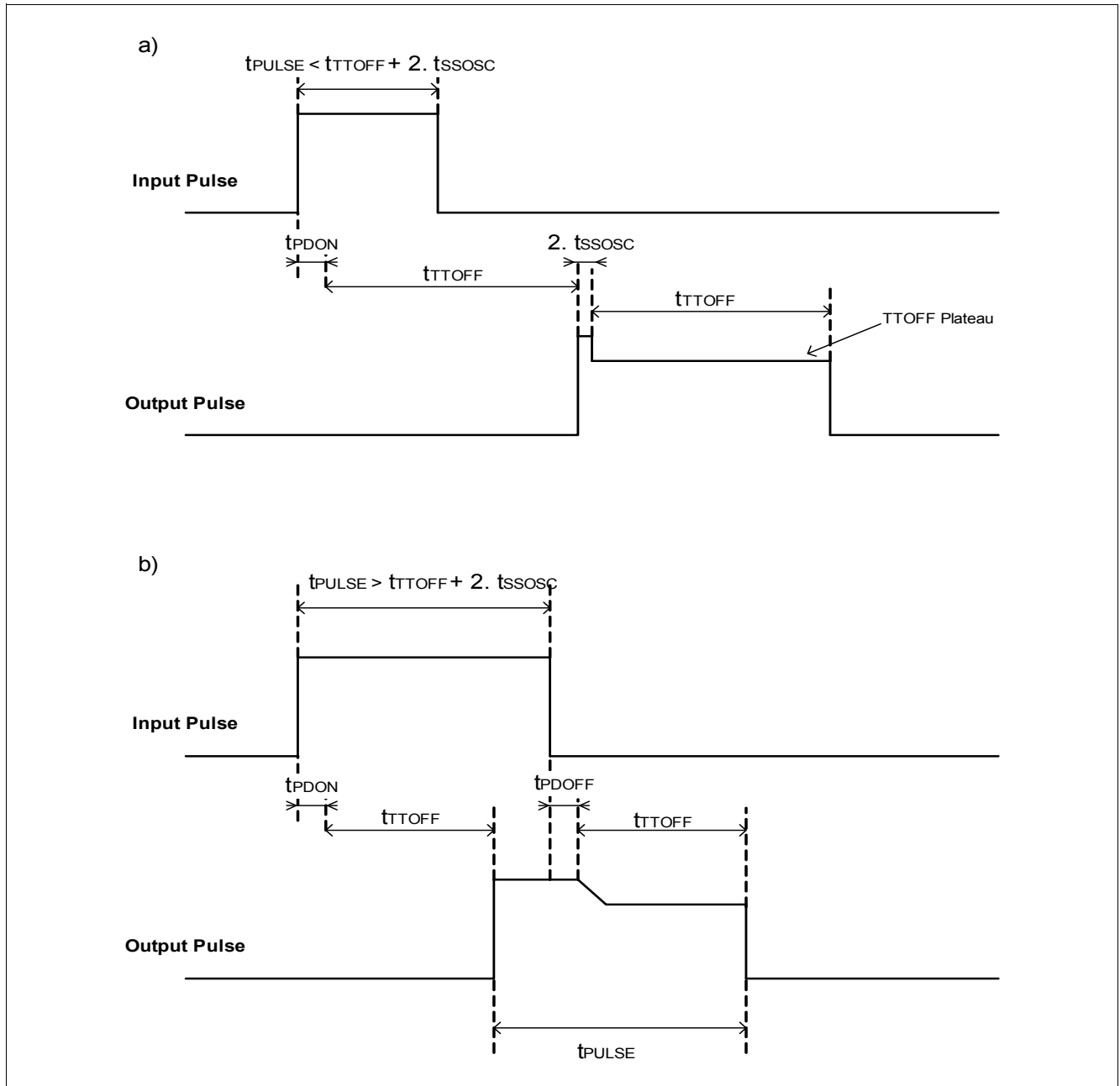

Figure 2-13 TTOFF: Principle of Operation

Two Level Turn-On (TTON)

In order to increase EM compatibility and the efficiency of the whole system, the 1EDI2010AS supports the Two Level Turn-On functionality (TTON). The TTON function consists in switching the IGBT on in three steps in such a way that:

1. The IGBT gate voltage is first increased until a specific (and programmable) voltage is reached by the **TON** signal.
2. **TON** (and **TOFF**) voltage is stabilized at this level. The IGBT Gate voltage forms thus a plateau.
3. Finally, the switch-on sequence is resumed up to the maximum output voltage.

The TTON feature needs to be activated by configuring the delay with bit field **STTON.TTONVAL**.

The plateau voltage level can be configured during run time by updating bit field **PCTRL.GPON**. This bit field can also be programmed to a value generating a hard turn-on.

When using the TTON function (with a non-zero delay), the PWM command is received on pin **INP** is **not** delayed by the programmed TTON delay time (**Figure 2-14**). However, the minimum pulse width that can be generated corresponds to the programmed TTON delay. Thus, for input pulses smaller than the TTON delay ($t_{PULSE} < t_{TTON}$), the output pulse width is extended.

The device allows for external booster voltage compensation at the IGBT gate. When bit **SCFG.VBEC** is cleared, the voltage at **TON** at the plateau corresponds to the programmed value. When bit **SCFG.VBEC** is set, an additional V_{BE} (base emitter junction voltage of an internal pn diode) is **added** to the programmed voltage at **TON** in order to compensate for the V_{BE} of an external booster.

The TON and TTOFF functions can be used simultaneously.

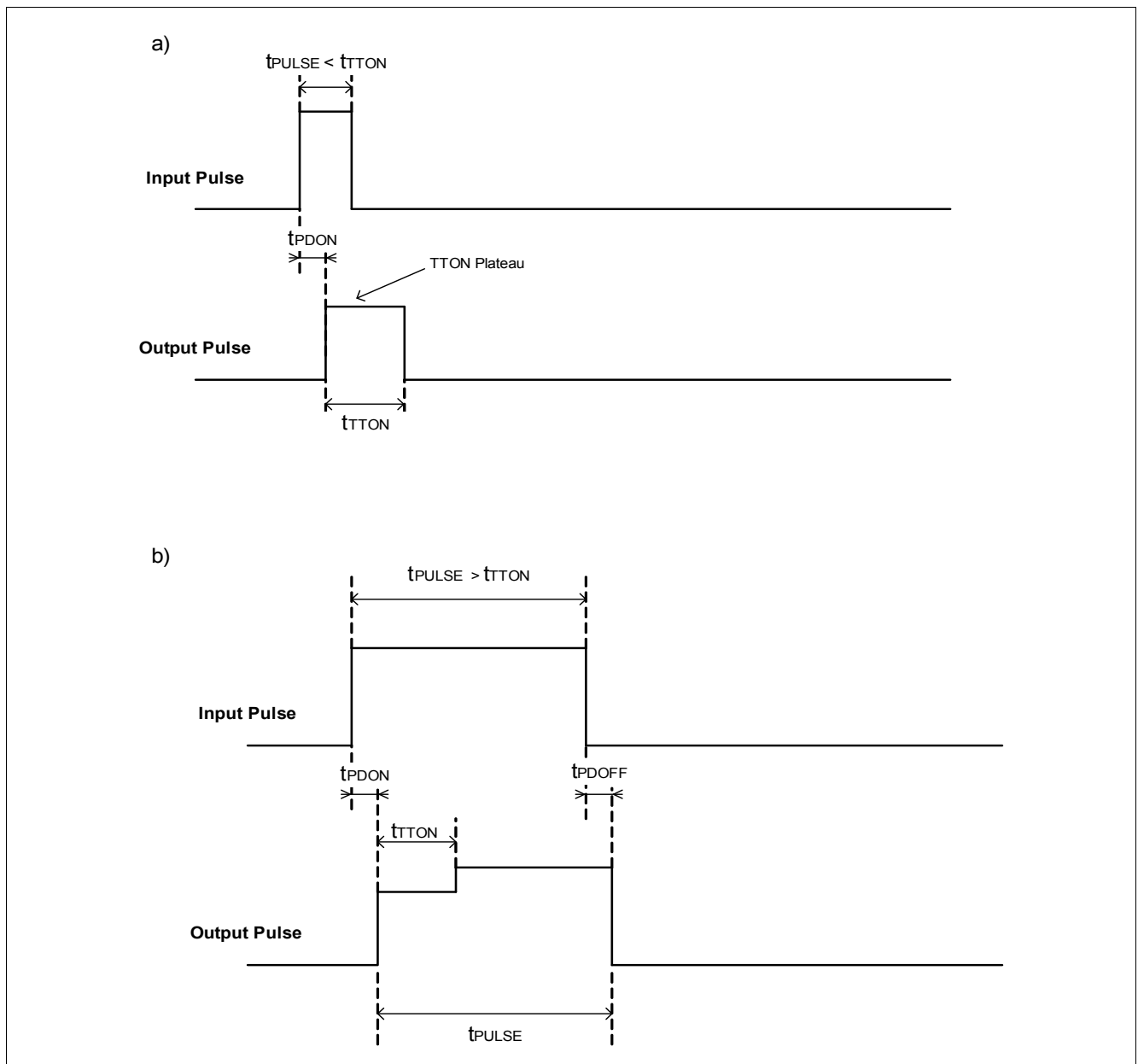

Figure 2-14 TTON: Principle of Operation

Pulse Suppressor

In order to increase the device's robustness against external disturbances, a pulse suppressor can be enabled by setting bit **SCFG.PSEN**. Register **SRTTOF** shall also be programmed with a value higher than 2_{H_1} . When a PWM turn-on sequence occurs, the activation of the output stage is delayed by the programmed TTOFF number of cycles, as for a normal TTOFF sequence. However, the PWM command received by the secondary chip signal is internally sampled at every SSOSC cycle before the actual turn-on command is executed by the output stage. If at least one of the sampling points does not detect a high level, the turn-on sequence is aborted and the device is not switched on.

In case a valid PWM ON command is detected by the secondary side after the decision point the previous sequence has been aborted, a new turn-on sequence is initiated.

One of the consequences of activating the pulse suppressor is that all PWM pulses shorter than the programmed TTOFF plateau time are filtered out (**Figure 2-15**).

Note: The Pulse Suppressor only acts on turn-on pulses, not on turn-off pulses.

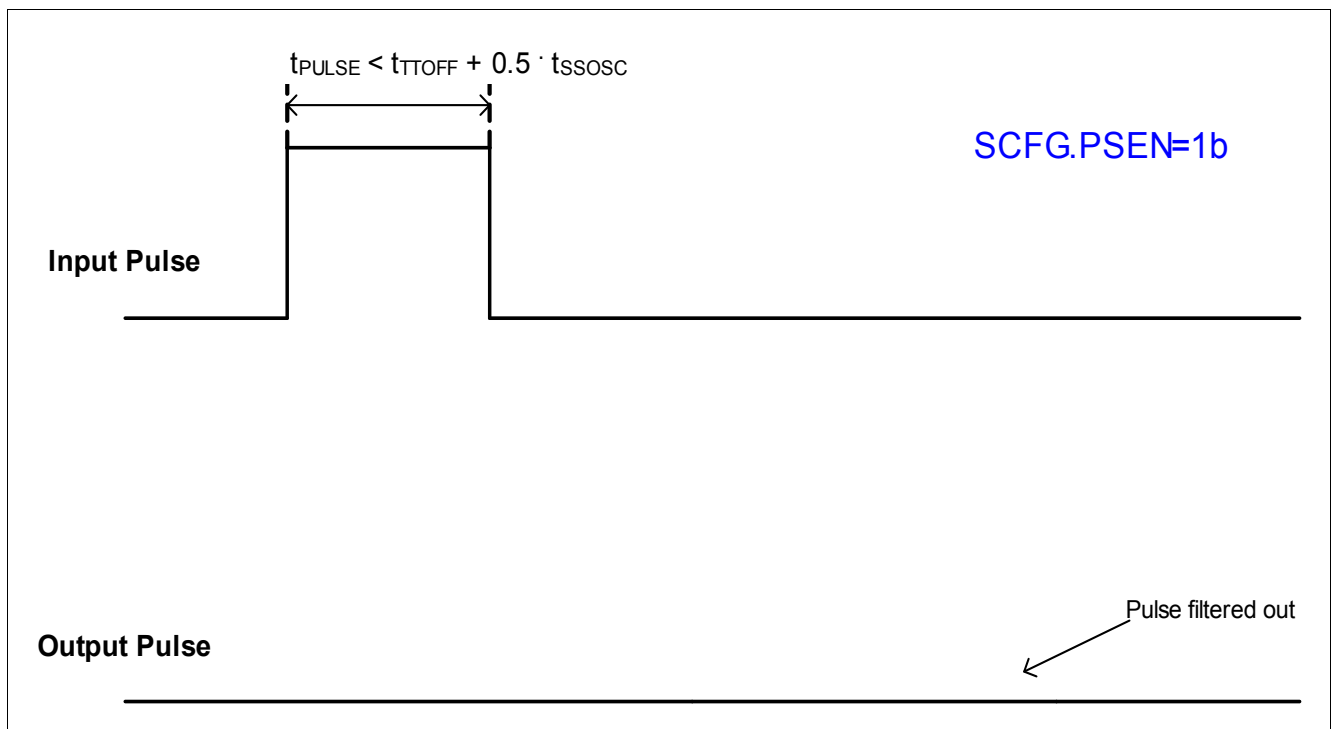

Figure 2-15 TTOFF: pulse suppressor aborting a turn-on sequence

2.4.6.2 Switching Sequence Description

Figure 2-16 shows an idealized switching sequence. When a valid turn-on command is detected, a certain propagation time t_{PDON} is needed by the logic to transfer the PWM command to the secondary side. At this point the TTOFF delay time t_{TTOFF} defined by bit field **SRTTOF.RTVAL** is added before the turn-on command is executed. Signal **TON** is then activated, while signal **TOFF** is deactivated.

In case the two level turn-on function is active, signal **TON** is increased up to the plateau voltage defined by bit field **PCTRL.GPON**. The duration t_{TTON} between the beginning of the turn-on sequence and the moment where the switching sequence is resumed is defined by bit field **STTON.TTONVAL**.

When a valid turn-off command is detected, a certain propagation time t_{DOFF} is needed by the command to be processed by the logic on the secondary side. This propagation time depends on the event having generated the turn-off action (non exhaustive list):

- In case of a PWM turn-off command at pin **INP**, $t_{DOFF}=t_{PDOFF}$.
- In case of a DESAT Event, $t_{DOFF}=t_{OFFDESAT2}$.
- In case of an OCP event, $t_{DOFF}=t_{OFFOCP2}$.
- In case of an Event Class A on the primary side: $t_{DOFF}=t_{OFFCLA}$.
- In case of an Event Class B on the secondary side: $t_{DOFF}=t_{OFFCLB2}$.

When the turn-off command is processed by the logic, signals **TON** and **TOFF** are decreased with the slew rate t_{SLEW} fixed by hardware. Once the voltage at pin **TOFF** has reached the value defined by bit field **PCTRL2.GPOF** (or **SSTTOF.GPS** in the case of a safe turn-off), the turn-off sequence is interrupted. Time t_{TTOFF} is defined as the moment when the device starts turning off signal **TOFF**, and the moment where the turn-off sequence is resumed. Depending on the event that triggered the turn-off sequence, t_{TTOFF} is given by either bit field **SRTTOF.RTVAL** or **SSTTOF.STVAL**. Once the TTOFF time has elapsed, a hard commutation takes place, and signals **TON** and **TOFF** are driven to V_{EE2} .

Note: Once a turn-off sequence is started, it is completed to the end with the same delay parameters.

Signal **DACLP** can be activated by configuring bit field **SCFG.DACL**. At the moment when the hard commutation takes place, signal **DACLP** remains deactivated for time t_{ACL} fixed by hardware. When this time is elapsed, signal **DACLP** is reactivated (i.e. active clamping is disabled). The voltage level at pin **DACLP** can be read at bit **SSTAT2.DACL**

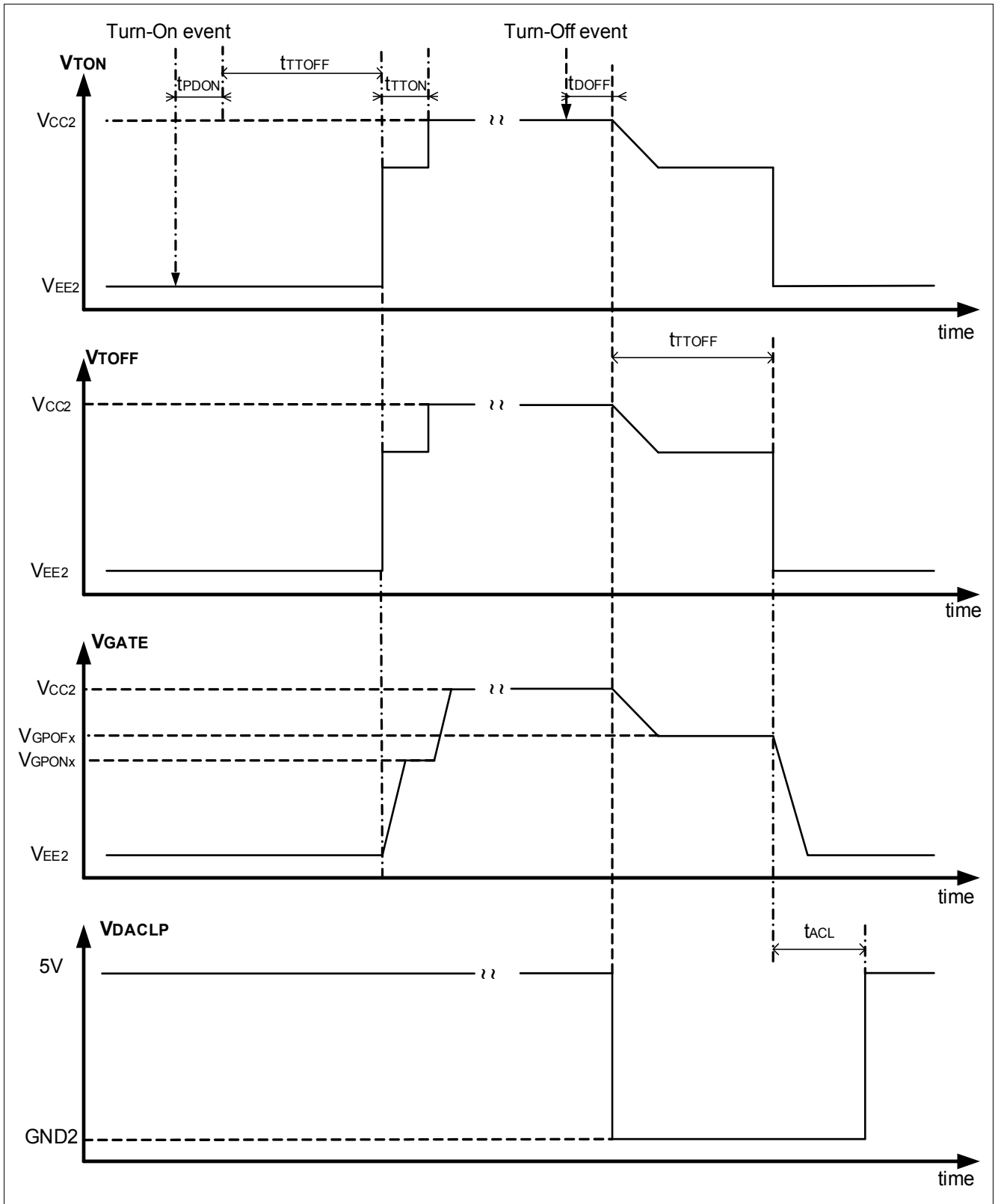

Figure 2-16 Idealized Switching Sequence

2.4.6.3 Passive Clamping

When the secondary chip is not supplied, signals **TOFF**, **TON** and **GATE** are clamped to V_{EE2} . The **GATE** pin is the sensing pin for this clamping and should be not overstressed. See “Electrical Characteristic” section for the electrical capability of this feature.

2.4.7 Fault Notifications

The device provides two kinds of fault notification mechanisms:

- Pins **NFLTA**, **NFLTB** and **NRST/RDY** allow for fast error notification to the main microcontroller. All signals are active low.
- Error bits can be read by SPI.

The activation of signal **NRST/RDY** is associated with Reset Events (see [Chapter 2.4.10](#)). The activation of signal **NFLTA** is associated with Class A Events. The activation of signal **NFLTB** is associated with Class B Events. In general the activation of signal **NFLTA** or **NFLTB** is linked to a state transition of the state machine.

Handling Events Class A and B

If an Event Class A occurs that leads to a state transition (from OPM4 to OPM3 or OPM6 to OPM5), signal **NFLTA** is activated. In case an Event Class A occurs that does not lead to a state transition, **NFLTA** is not activated (exception: ADC boundary check events). However, the corresponding error bit in register **PER** or **SER** is set.

ADC Boundary Check events are handled in a special way. In case bit **SCFG2.ACAEN** is set, an ADC Boundary Check event leads to an Event Class A: an Emergency (regular) turn-off sequence is issued, and possibly a transition of the state machine and the activation of **NFLTA**. Bit **SSTAT.FLTAS** (and resultingly bit **PSTAT2.FLTAP**) is set as long as bits **SADC.AOVS** or **SADC.AUVS** is set.

In case bit **SCFG2.ACAEN** is cleared, an ADC Boundary Check event does not lead to a transition of the state machine (**NFLTA** is not activated). Besides, no Emergency Turn-Off sequence is initiated. However, bit **SER.AUVER** and / or **SER.AOVER** is set. Therefore, when bit **SCFG2.ACAEN** is cleared, the ADC Boundary Check mechanism behaves like an Event Class C.

Additionally, signal **NFLTA** can be activated directly by the status bits related to boundary check on the primary side. This allows to have signal **NFLTA** activated in any OPM mode in case of ADC Boundary Check Events. If bit **PCFG.ADAEN** is set, **NFLTA** is activated at the transition of bit **PSTAT2.AXVP** from 0_B to 1_B .

If an Event Class B occurs that leads to a state transition (to OPM1), signal **NFLTB** is activated. In case an Event Class B occurs that does not lead to a state transition, **NFLTB** is not activated. However, the corresponding error bit in register **PER** or **SER** is set.

The level issued by the device on pins **NFLTA** and **NFLTB** is given by bits **PSTAT2.FLTA** and **PSTAT2.FLTB**. The levels read by the device at those pins is given by bits **PPIN.NFLTAL** and **PPIN.NFLTBL**. In case a condition leading to an Event Class A is detected by the device, bit **PSTAT2.FLTAP** is set. In case a condition leading to an Event Class B is detected by the device, bit **PSTAT2.FLTBP** is set.

*Note: In case of short events (e.g. Desat or OCP event), it might not be possible to observe a change of the state of bits **PSTAT2.FLTAP** or **FLTBP**.*

Clearing Fault Notifications

Table 2-12 summarizes how fault notifications are cleared:

Table 2-12 Failure Notification Clearing

	NFLTA / B signals	Primary Sticky Bits	Secondary Sticky Bits
PCTRL.CLRP set	De-assertion	Cleared	-
PCTRL.CLRS set ¹⁾	-	-	Cleared
EN Invalid to Valid transition	De-assertion ²⁾	-	-

1) If the device is in OPM1, setting bit **SCTRL.CLRS** leads to a transition to OPM0

2) Only in OPM3 and OPM5. In other Operating Modes, no de-assertion is done.

A CLRCP command (i.e. setting bit **PCTRL.CLRP**) clears all sticky bits on the primary side. A CLRS command (i.e. setting bit **PCTRL.CLRS**) clears all sticky bits on the secondary side.

Signals **NFLTA** and **NFLT B** are de-asserted with an invalid to valid transition of signal **EN**. Besides, they can be de-asserted by a CLRCP command, depending on the device' status.

s
•

2.4.8 EN Signal Pin

The **EN** signal allows the logic on the primary side to have a direct control on the state of the device. A valid signal has to be provided on this pin. A valid to invalid transition of the signal on pin **EN** generates an Event Class A.

Pin **EN** should be driven actively by the external circuit. In case this pin is floating, an internal weak pull-down resistor ensures that the signal is low.

*Note: It should be noted that even if the signal at pin **EN** is valid, the device can still be in disabled state. This may happen for example if another error is being detected*

A valid **EN** signal is defined as a digital High level. When **EN** is at Low level, the signal is considered as not valid and the device is in Disabled State. In case of a High-to-Low transition, an Event Class A is generated.

An Invalid to Valid transition of signal **EN** deactivates signals **NFLTA** and **NFLT B** (when the device is in OPM3 or OPM5 only).

The levels read by the device at pin **EN** is given by bits **PPIN.ENL**. The validity status of **EN** signal is given by bit **PSTAT2.ENVAL**.

2.4.9 Internal Supervision

The Internal Supervision functionality is summarized in [Table 2-13](#):

Table 2-13 System Supervision Overview

Parameter	Short Description
Function	Monitoring of the key internal functions of the chip.
Periodicity	Continuous.
Action in case of failure event	See below
Programmability	No.

The primary and secondary chips are equipped with internal verification mechanisms ensuring that the key functions of the device are operating correctly. The internal blocks which are supervised are listed below:

- Lifesign watchdog: mutual verification of the response of both chips (both primary and secondary).
- Oscillators (both primary and secondary, including open / short detection on signals [IREF1](#)).
- Memory error (both primary and secondary).

2.4.9.1 Lifesign watchdog

The primary and the secondary chips monitor each other by the mean of a lifesign signal. The periodicity of the lifesign is typically t_{LS} . Each chip expects a lifesign from its counterpart within a given time window. In case a lifesign error is detected by a chip, a reset event is generated on both sides (lead to OPM0) as well as NFLTB pin is set. Due to the communication loss on both sides both bits [PER.CERP](#) and [SER.CERS](#) are set.

Note: Bits [PER.CERP](#) and [SER.CERS](#) indicate a loss of communication event. The current status of the internal communication is indicated by bit [PSTAT.SRDY](#).

2.4.9.2 Oscillator Monitoring

The main oscillators on the primary and on the secondary side are monitored continuously. Two distinct mechanisms are used for this purpose:

- Lifesign Watchdog allows to detect significant deviations from the nominal frequency (both primary and secondary, see above).
- Open / short detection on pin [IREF1](#).

In case a failure is detected on pin [IREF1](#), the primary chip is kept in reset state for the duration of the failure and signal [NRST/RDY](#) is asserted, This leads to the detection of a lifesign error by the secondary chip, generating thus an reset event.

2.4.9.3 Memory Supervision

The configuration parameters of the device, stored in the registers, are protected with a parity bit protection mechanism. Both primary and secondary chips are protected (refer to [Chapter 4](#)).

In case a failure is detected on the primary chip, it is kept in reset state, and both signal [NRST/RDY](#) and [NFLTB](#) are asserted. The secondary side initiates an Emergency (Regular) Turn-Off sequence.

In case a memory failure is detected by the secondary chip, an Emergency (Regular) Turn-Off sequence is initiated. The secondary chip is kept in reset state for the duration of the failure. This leads to the detection of a lifesign error by the primary chip, generating thus an reset event.

2.4.9.4 Hardware Failure Behavior

The internal supervision function can detect several failures which could lead to primary or secondary chip hold on (stay in reset). Failures which can be detected are mentioned in the table below. The supervision functions described in the chapters before will lead to this behavior.

Table 2-14 Failure Events Summary

Failure Event	Primary	Secondary	Notification (primary)	Notification (secondary)
OSC1 not starting at power-up	Reset	Soft Reset	<ul style="list-style-type: none"> • NRST/RDY Low (driven by device during event). • Bit PER.RSTP set (once OSC1 valid again). • Bit PER.CERP is not set. • NFLT activated at the end of the reset event. 	<ul style="list-style-type: none"> • Bit SER.CERS set (in case of lifesign lost). • Output Stage issues a PWM OFF command.
IREF1 shorted to ground or open	Reset	Soft Reset	<ul style="list-style-type: none"> • NRST/RDY Low (driven by device during event). • Bit PER.RSTP set (once IREF1 valid again). • Bit PER.CERP is not set. • NFLT activated at the end of the reset event. 	<ul style="list-style-type: none"> • Bit SER.CERS set (in case of lifesign lost). • Output Stage issues a PWM OFF command.
Memory error on primary	Reset	Soft Reset	<ul style="list-style-type: none"> • NRST/RDY Low (driven by device during event). • Bit PER.RSTP set (when failure condition is removed). • Bit PER.CERP is not set. • NFLT activated at the end of the reset event. 	<ul style="list-style-type: none"> • Bit SER.CERS set (in case of lifesign lost). • Output Stage issues a PWM OFF command.
OSC2 not starting at power-up	-	Hard Reset	<ul style="list-style-type: none"> • NFLT activated, bit PER.CERP set. • Bit PSTAT.SRDY cleared 	<ul style="list-style-type: none"> • Output Stage issues a PWM OFF command.
OSC2 malfunction during operation	-	Soft Reset	<ul style="list-style-type: none"> • NFLT activated, bit PER.CERP set. • Bit PSTAT.SRDY cleared for the duration of the failure. 	<ul style="list-style-type: none"> • Output Stage issues a PWM OFF command.
VREG shorted to ground	-	Hard Reset	<ul style="list-style-type: none"> • NFLT activated, bit PER.CERP set. • Bit PSTAT.SRDY cleared. 	<ul style="list-style-type: none"> • Output Stage issues a PWM OFF command. • Bit SER.RSTS (once V_{CC2} valid again).
Memory error on secondary	-	Hard Reset	<ul style="list-style-type: none"> • NFLT activated, bit PER.CERP set. • Bit PSTAT.SRDY cleared. 	<ul style="list-style-type: none"> • Output Stage issues a PWM OFF command.

2.4.10 Reset Events

A reset event sets the device and its internal logic in the default configuration. All user-defined settings are overwritten with the default values. The list of reset events and their effect is summarized in [Table 2-15](#).

Table 2-15 Reset Events Summary

Reset Event	Primary	Secondary	Notification (primary)	Notification (secondary)
NRST/RDY input signal active (driven externally)	Reset	Soft Reset	<ul style="list-style-type: none"> • NRST/RDY Low (during event). • Bit PER.RSTEP and PER.RSTP set. • Bit PER.CERP is not set. • NFLT B activated at the end of the reset event. 	<ul style="list-style-type: none"> • Bit SER.CERS set (in case of lifesign lost). • Output Stage issues a PWM OFF command.
UVLO1 Event	Reset	Soft Reset	<ul style="list-style-type: none"> • NRST/RDY Low (driven by device during event). • Bit PER.RSTP set (once V_{CC1} valid again). • Bit PER.CERP is not set. • NFLT B activated at the end of the reset event. 	<ul style="list-style-type: none"> • Bit SER.CERS set (in case of lifesign lost). • Output Stage issues a PWM OFF command.
V_{CC2} reset event (communication loss due to voltage breakdown on V_{CC2})	-	Hard Reset	<ul style="list-style-type: none"> • NFLT B activated, bit PER.CERP set. • Bit PSTAT.SRDY cleared for the duration of the failure. 	<ul style="list-style-type: none"> • Bit SER.RSTS (once V_{CC2} valid again). • Output Stage issues a PWM OFF command.

All reset events set the device in Mode OPM0. In a soft reset, the logic works further, but the registers use the default values.

In case of a reset condition on the primary side, the behavior of the pin of the device is defined in [Table 2-16](#).

Table 2-16 Pin behavior (primary side) in case of reset condition

Pin	Output Level	Comments
SDO	Tristate	
NFLT B	Low	
NFLT A	Low	
NRST/RDY	Low (GND1)	

In case of a hard reset condition on the secondary side, the behavior of the pin of the device is defined in [Table 2-17](#).

Table 2-17 Pin behavior (secondary side) in case of reset condition

Pin	Output Level	Comments
TON	Low (V_{EE2})	Passive Clamping
TOFF	Low (V_{EE2})	Passive Clamping
DESAT	Low (GND2)	Clamped.

Table 2-17 Pin behavior (secondary side) in case of reset condition

Pin	Output Level	Comments
GATE	Low (V_{EE2})	Passive Clamping
DACL	High (5V)	

2.4.11 Operation in Configuration Mode

This section describes the mechanisms to configure the device.

2.4.11.1 Static Configuration Parameters

Static parameters can be configured when the device is in Mode OPM2 by writing the appropriate configuration register.

Once Mode OPM2 is left with the SPI Command EXIT_CM0DE, the configuration parameters are frozen on both primary and secondary chips. This means in particular that write accesses to the corresponding registers are invalidated. This prevents static configurations to be modified during runtime. Besides, the configuration parameters on the primary and secondary side are protected with a memory protection mechanism. In case the values are not consistent, a Reset Event and / or an Event Class B is generated.

2.4.11.1.1 Configuration of the SPI Parity Check

The SPI interface supports by default an odd parity check. The Parity Check mechanism (active at the reception of an SPI word) can be disabled by setting bit **PCFG.PAREN** to 0_B. Setting bit **PAREN** to 1_B enables the Parity Check.

Parity Bit Generation for the transmitter can not be disabled.

2.4.11.1.2 Configuration of NFLTA and NFLTB clear mode

The reaction of signals **NFLTA** and **NFLTB** to a clear primary command is defined by the values of respectively bits **PCFG.CLFAM** and **PCFG.CLFBM**. See [Chapter 2.4.7](#) for more details.

2.4.11.1.3 Configuration of NFLTA activation in case of Boundary Check event

Signal **NFLTA** is normally activated by a state transition of the internal state machine. However, it can also be configured to be activated in relation with bit **PSTAT2.AXVP**. This is configured thanks to bit **PCFG.ADAEN**.

2.4.11.1.4 Configuration of pin ADCT

Signal **ADCT** can be used as a trigger source for the ADC on the secondary side. If **PCFG.ADTEN** is cleared, the voltage read on the pin is ignored by the device. If **PCFG.ADTEN** is set, an ADC conversion is triggered at a rising edge detected at pin **ADCT**.

2.4.11.1.5 Configuration of the STP Minimum Dead Time

The minimum dead time for the Shoot-Through Protection can be programmed by writing bit field **PCFG2.STPDEL**. The value programmed corresponds to a number of OSC1 clock cycles.

2.4.11.1.6 Configuration of the Digital Channel

The direction of pin can be programmed by writing bit field **PCFG2.DIO1**. The direction of pin **DIO2** can be programmed by writing bit field **SCFG.DIO2C**.

2.4.11.1.7 Configuration of the V_{BE} Compensation

The V_{BE} compensation of signal **TON** and **TOFF** can be activated or deactivated by writing bit **SCFG.VBEC**. See **Chapter 2.4.6** for more details.

2.4.11.1.8 Clamping of DESAT pin

By setting bit **SCFG.DSTCEN**, the DESAT signal is clamped to V_{GND2} while the output stage of the device issues a PWM OFF command and during blanking time periods. By clearing bit **SCFG.DSTCEN**, the DESAT clamping is only activated during blanking time periods.

2.4.11.1.9 Activation of the Pulse Suppressor

The pulse suppressor function is associated with the TTOFF function and can be activated by setting bit **SCFG.PSEN**. When activated, **SRTTOF.RTVAL** shall be programmed with a minimum value.

2.4.11.1.10 Configuration of the Verification Mode Time Out Duration

The duration of the time out in verification mode is selectable via bit **SCFG.TOSEN**.

2.4.11.1.11 DESAT Threshold Level Configuration

The detection level of the **DESAT** comparator is selectable via bit **SCFG.DSATLS**.

2.4.11.1.12 UVLO2 Threshold Level Configuration

The detection levels of the UVLO2 comparators are selectable via bit **SCFG.UVLO2S**.

2.4.11.1.13 DACLP Operating Mode Configuration

The operating mode of pin **DACL**P is selectable via bit field **SCFG.DACL**C.

2.4.11.1.14 Configuration of the ADC

The configuration of the ADC is selectable by writing register **SCFG2**. The limits of the boundary checker are selectable by writing register **SBC**.

*Note: Registers **SCFG2** and **SBC** can only be written if bit **SCFG.CFG2** is set to 1_B.*

2.4.11.1.15 Configuration of the DESAT Blanking Time

The blanking time for the DESAT protection can be configured by writing bit field **SDESAT.DSATBT**. A minimum value for the blanking time has to be programmed.

Note: The programmed OCP blanking time shall be smaller than the programmed DESAT blanking time.

2.4.11.1.16 Configuration of the OCP Function

The blanking time for the OCP protection can be configured by writing bit field **SOCP.OCPBT**. Programming 0_H deactivates the blanking time feature. In case a blanking time is required, a minimum value for the delay has to be programmed. The detection level of the OCP comparator is selectable via bit **SCFG.OCPPLS**.

Note: The programmed OCP blanking time shall be smaller than the programmed DESAT blanking time.

2.4.11.1.17 Configuration of the TTOFF sequences

The TTOFF delays for Regular and Safe Turn-Off sequences can be programmed separately by writing registers **SRTTOF** or **SSTTOF**. The delay for Regular Turn-Off can also be configured using the Timing Calibration Feature.

Programming 0_H as a delay value disables the TTOFF for the concerned Turn-Off Sequence. Hard turn-off are performed instead. In case the TTOFF function is wished, a minimum value for the delay has to be programmed. When safe two level turn-off is used (non zero delay) in normal operating mode (OPM4), the programmed safe turn-off delay value shall be higher than the programmed regular two level turn of delay.

The plateau level for safe two level turn off sequences can be programmed with bit field **SSTTOF.GPS**. The plateau level value for safe turn-off sequences shall be lower than the one selected for regular turn-off sequences. The regular TTOFF delay can be calibrated using the TCF feature of the device.

2.4.11.1.18 Configuration of the TTON Delay TO Update

The TTON delay can be configured by writing bit field **STTON.TTONVAL**. Programming 0_H as a delay value disables the TTON for all turn-on sequences. Hard turn-on are performed instead. In case the TTON function is wished, a minimum value for the delay has to be programmed.

The TTON delay can be calibrated using the TCF feature of the device.

2.4.11.2 Dynamic Configuration

The TTOFF (regular turn-off only) plateau level can be modified during runtime by writing bit field **PCTRL2.GPOF**. The value of this bit field is periodically transferred to the secondary side. The last valid received value by the primary side is available at bit field **PSTAT.GPOFP**. The value currently used by the secondary chip is available at bit field **SCTRL.GPOFS**.

Similarly, The WTO and the TTON plateau level can be configured by writing bit field **PCTRL.GPON**. The value of this bit field is periodically transferred to the secondary side. The last valid received value by the primary side is available at bit field **PSTAT.GPONP**. The value currently used by the secondary chip is available at bit field **SCTRL.GPONS**.

The plateau value stored in the device at the beginning of the corresponding switching sequence is latched and active until the upper next switching sequence.

2.4.11.3 Delay Calibration

In order to compensate for timing errors due to part-to-part variations, a dedicated Timing Calibration Feature (TCF) has been implemented. The TCF works in such a way that the PWM input signal is used to start and stop a counter clocked by the Start-Stop Oscillator of the Output Stage. As a result, the following delays and timing can be configured that way:

- TTOFF delay for Regular Turn-Off.
- TTON delay.

The TCF allows to compensate for part to part variations of the frequency of the Start-Stop oscillator. This results in better accuracy for application critical timing. Device specific variations, e.g. temperature related, are not compensated though. The TCF can be activated or deactivated in Configuration Mode by writing bit field **SSCR.VFS2**. The device shall then be set in OPM6 and the PWM signal applied. Details about the TCF operation are given in **Chapter 3.5.3**.

2.4.12 Low Latency Digital Channel

The low latency digital channel aims at providing an alternative to discrete galvanic isolators. Digital signals can be transmitted through pins **DIO1** and **DIO2**. The direction of the channel is given by bit field **PCFG2.DIO1** and **SCFG.DIO2C**. The functionality of the channel is shown **Figure 2-17**.

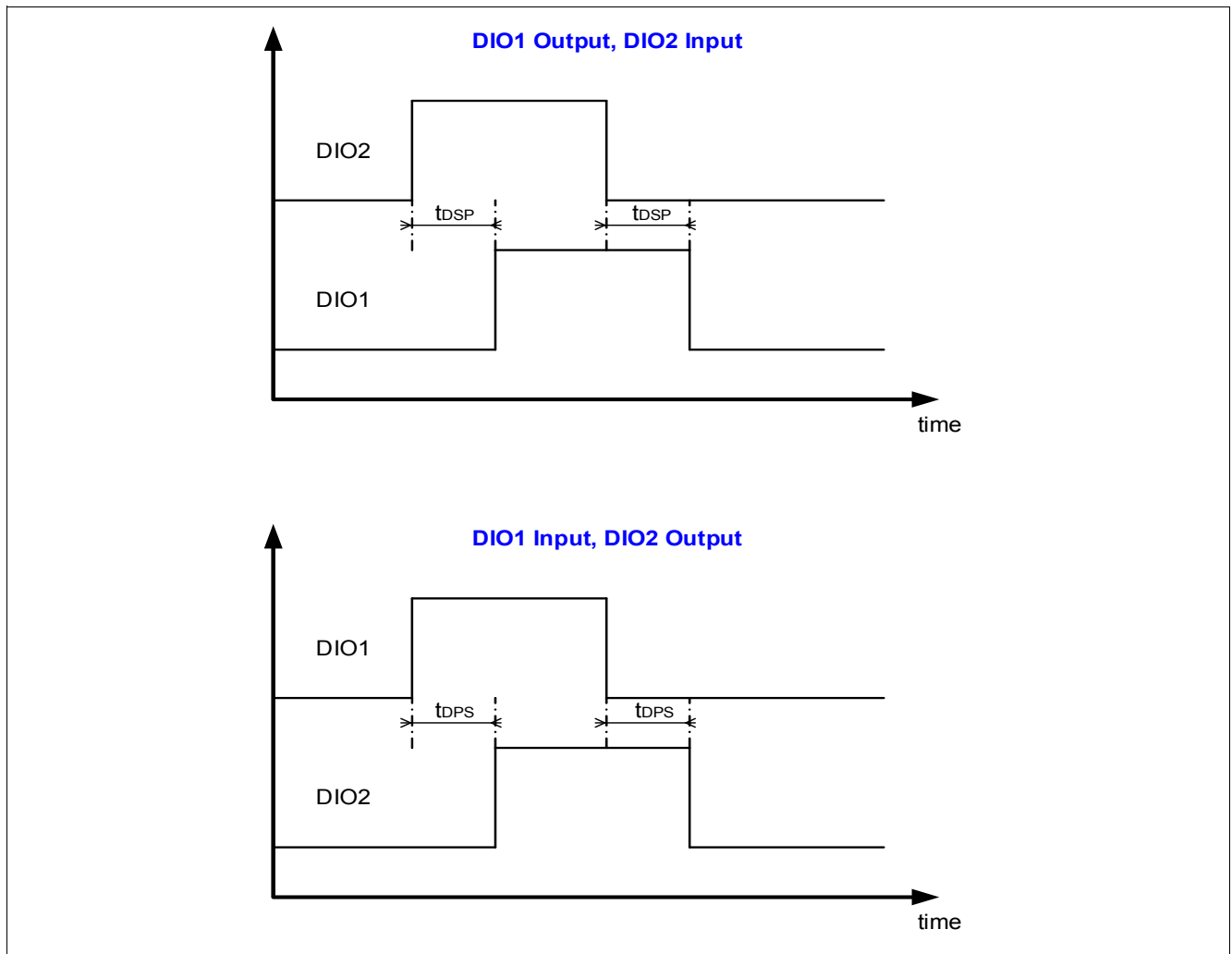

Figure 2-17 Low Latency Digital Channel

The voltage level at pin **DIO1** can be read at bit **PPIN.DIO1L**. The voltage level at pin **DIO2** can be read at bit **SSTAT2.DIO2L**.

The input stages of signals **DIO1** and **DIO2** include each a Debouncing Filter. The input signals are that way filtered from glitches and noise.

2.4.13 Analog Digital Converter

2.4.13.1 Overview

The key properties of the built-in ADC on the secondary side are:

- Successive Approximation method.
- 0V to 5 V input signal (input buffer).
- 8-bit resolution.
- Fast conversion time.
- Preamplifier with programmable gain.
- Selectable offset.

The ADC operates by the method of the successive approximation. The ADC offers a flexible analog measurement capability, which fulfills the following functions (non exhaustive list):

- Measurement of a NTC resistor located on the power module ([Figure 2-18](#)).
- Measurement of a temperature diode integrated into the IGBT ([Figure 2-19](#)).
- Measurement of the high voltage DC-Link or phase voltage ([Figure 2-20](#)).

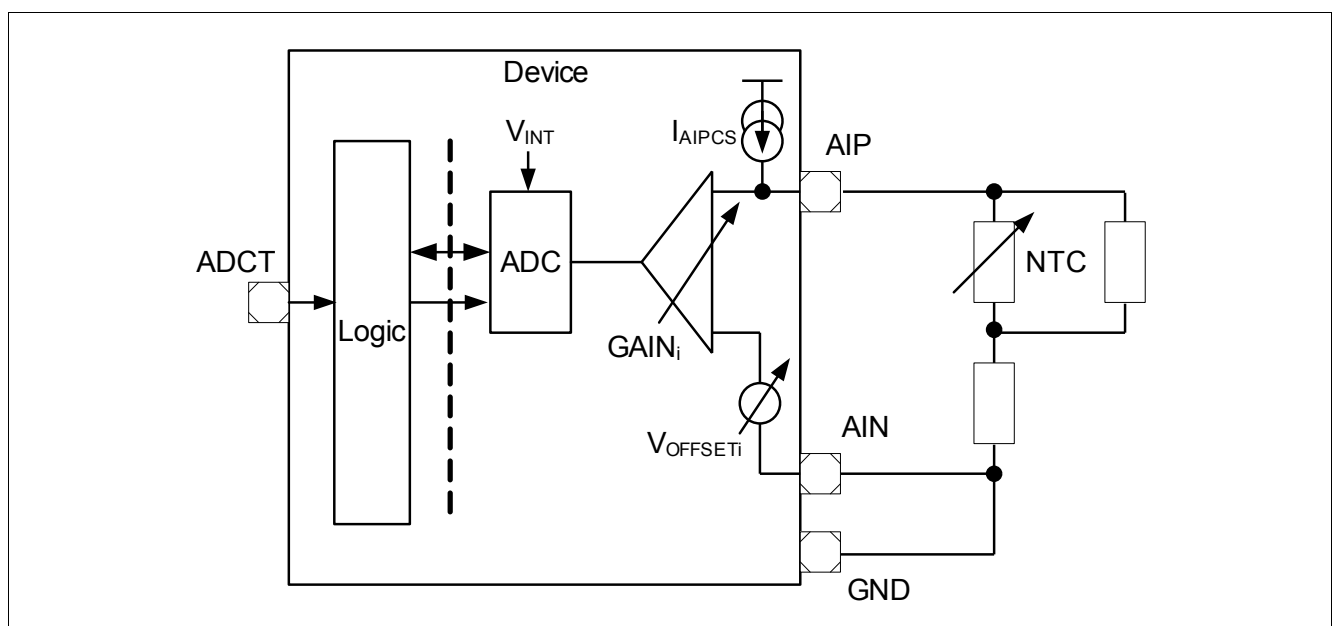

Figure 2-18 Application Example NTC Measurement

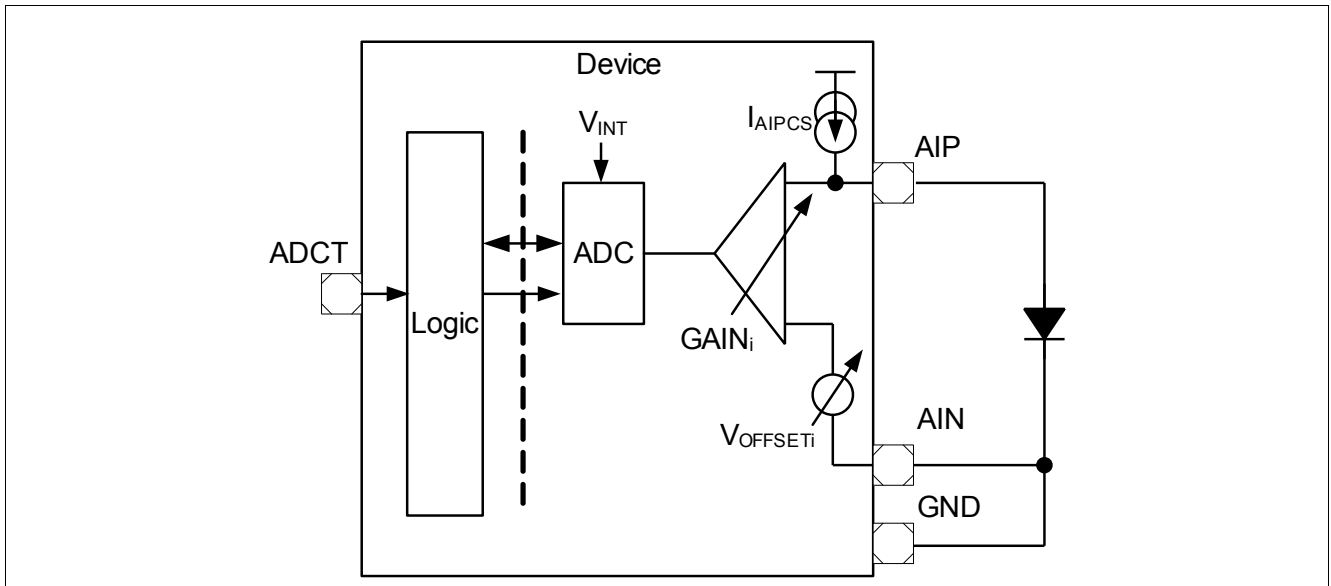

Figure 2-19 Application Example: Diode Measurement

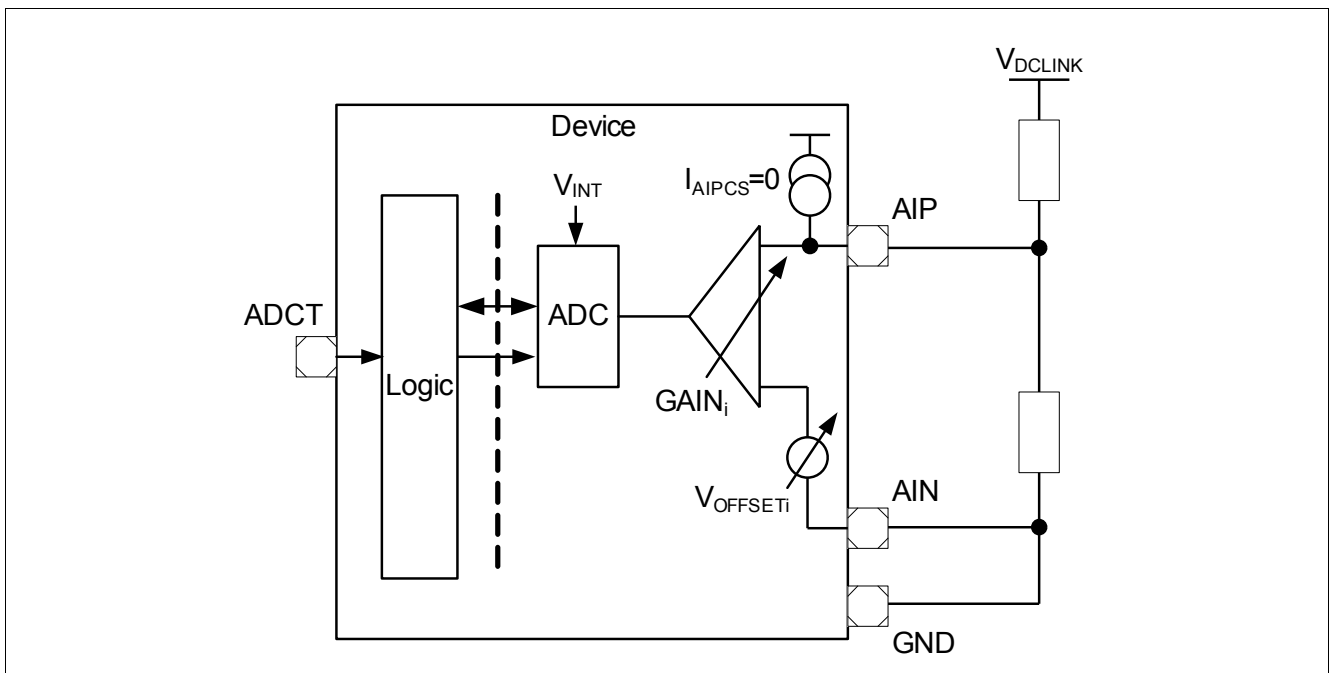

Figure 2-20 Application Example: V_{DCLINK} Measurement

Note: The internal current source can be disabled by writing 0 to bit [SCFG2.ACSS](#).

2.4.13.2 General Operation

When it receives a valid trigger, the ADC samples the voltage provided by the input buffer. The result of the conversion is stored as a 8-bit value.

The input buffer captures the voltage $V_{AIP} - V_{AIN}$. 0V ($V_{AIP} = V_{AIN}$) is converted as digital value 00_H by the ADC. The conversion voltage range depends on the programmed gain of the input buffer. For example, if GAIN = 1 and $V_{OFFi} = 0V$ is programmed, $V_{AIP} - V_{AIN} = 2.75V$ corresponds to digital value FF_H.

Once the conversion is completed, bit field **SADC.ADCVAL** is updated and bit **SADC.AVFS** is set. This Valid Flag can be cleared by SPI by a CLRS command.

In case a trigger is received while a conversion is already in progress, any new conversion request is ignored until the running conversion is completed.

Since the ADC can be assigned (statically) to different functions by the application, several operating modes can be chosen from in order to suit each of those specific roles. The configuration of the operating mode is done via the SPI interface.

Trigger Sources

In order to start a conversion, several trigger sources are available. Primary trigger source enable to trigger a conversion via

- a direct SPI write command
- via pin **ADCT**.

In addition, trigger sources can be activated on the secondary side depending on the configuration of bit field **SCFG2.ATS**:

- Periodic trigger mode: in this mode, conversions are started automatically by the ADC at a periodical rate. The conversion period is fixed internally by design (parameter t_{ATRIG}).
- PWM trigger mode: in this mode, conversions are triggered by a PWM edge (rising or falling selectable). When the corresponding PWM signal is detected on the secondary side, a trigger is generated to the ADC after the delay programmed in bit field **SCFG2.PWMD**. The reference point for which the delay is started is the hard transition (ON or OFF).

Operation Mode

By setting **SCFG2.ACSS**, a current source can be activated that delivers a fixed current to pin **AIP**.

Gain and Offset Configuration

The gain and offset of the differential input buffer is configurable statically with bit fields **SCFG2.AGS** and **SCFG2.AOS**.

Mathematical Model

The following formula can be used to calculate a converted digital value from the voltage at the ADC input pins:

$$VAL_{DIG} = (V_{AIP} - V_{AIN} - V_{OFFi}) * GAIN_i * 255/V_{INT}, \text{ where:} \quad (2.1)$$

V_{INT} is the internal ADC voltage.

VAL_{DIG} is the digital value delivered by the ADC (from 0 to 255).

V_{AIP} is the voltage at pin **AIP**.

V_{AIN} is the voltage at pin **AIN**.

V_{OFFi} is the offset value selected by bit field **SCFG2.AOS**.

$GAIN_i$ is the gain value selected by bit field **SCFG2.AGS**.

2.4.13.3 Boundary Check

The Boundary Check mechanism automatically compares each conversion result to two boundary values. The result of the conversion is compared to the limits specified by bit fields **SBC.LCB1A** (lower limit) and **LCB1B** (upper limit).

When a new conversion result is available, the result is compared with the boundary values stored in register **SBC**. The values used for the comparison are respectively **SBC.LCB1A** extended by the LSBs $0_B 0_B$ (i.e.: $(LCB1A \ll 2) \& FC_H$) and **SBC.LCB1B** extended by the LSBs $1_B 1_B$ (ie: $(LCB1B \ll 2) | 03_H$).

In case the conversion result is below each of the boundaries, error flag **SER.AUVER** is set. In case the conversion result is above each of the boundaries, error flag **SER.AOVER** is set. In case the conversion result is above or equal one boundary and below or equal the other boundary, no flag is set. (If lower and upper limit are programmed in the other way around the device gives wrong limit cross notifications .)

The default limits are chosen such that the flags are never set whatever the conversion result is (equivalent to disabling the limit check).

The failure reaction of the device to a Boundary Check event can be programmed with bit **SCFG2.ADAEN**.

3 Protection and Diagnostics

This section can describes the safety relevant functions implemented in the 1EDI2010AS.

3.1 Supervision Overview

The 1EDI2010AS driver provides extended supervision functions, in order to support safety strategies on system level. **Table 3-1** gives an overview of the implemented functions.

Table 3-1 Safety Related Functions

Protection Feature	Description	Category	Comments
DESAT	Monitoring of the collector-emitter voltage of the IGBT in ON state.	A	See Chapter 3.2.1
OCP	Monitoring of the current on the IGBT's auxiliary emitter path.	A	See Chapter 3.2.2
External Enable	Fast deactivation via an external Enable signal on the primary.	A	See Chapter 3.2.3
ADC Boundary Check	ADC Boundary Check	A	See Chapter 2.4.13.3
Power Supply Monitoring	Under Voltage Lock-Out function on V_{CC1} , V_{CC2} .	B	See Chapter 3.3.1
STP	Shoot Through Protection.	C	See Chapter 3.4.1
SPI Error Detection	SPI Error Detection.	C	See Chapter 3.4.2
WTO	Weak Turn-On Functionality	D	See Chapter 3.5.2
Internal Clock Supervision	Plausibility check of the frequency of the internal oscillator.	D	See Chapter 3.5.3
TTOFF	Two Level Turn-Off	E	See Chapter 2.4.6
SPI Communication	SPI Communication (using register PRW).	E	See Chapter 4.1
Overtoltage robustness	Robustness against transient overvoltage on power supply.	E	See Chapter 5.2

From the conceptual point of view, the protection functions can be clustered into five main categories.

- Category A corresponds to the functions where the device “decides on its own”, after the detection of an Event Class A, to change the state of the output stage and to disable itself. A dedicated action from the user is needed to reactivate the device (fast reactivation).
- Category B corresponds to the functions where the device “decides on its own”, after the detection of an Event Class B, to change the state of the output stage and to disable itself. A complete reinitialization from the user is needed to reactivate the device (slow reactivation).
- Category C corresponds to the functions that only issue a notification in case an error is detected.
- Category D are intrusive supervision functions, aimed at being started when the application is not running.
- Category E corresponds to implemented functions or capabilities supported by the device whose use can enhance the overall safety coverage of the application.

3.2 Protection Functions: Category A

3.2.1 Desaturation Protection

The integrated desaturation (DESAT) functionality is summarized in [Table 3-2](#):

Table 3-2 DESAT Protection Overview

Parameter	Short Description
Function	Monitoring of the V_{CE} voltage of the IGBT.
Periodicity	Continuous while device issues a PWM ON command.
Action in case of failure event	<ol style="list-style-type: none"> 1. Emergency (Safe) Turn-off Sequence. 2. Error Flag SER.DESATER is set. 3. Assertion of signal NFLTA.
Programmability	Yes (blanking time & threshold level).

The DESAT function aims at protecting the IGBT in case of short circuit. The voltage drop V_{CE} over the IGBT is monitored via the **DESAT** pin while the device issues a PWM ON command. The voltage at pin **DESAT** is externally filtered by an external RC filter, and decoupled by an external diode (see [Figure 3-1](#)). The DESAT voltage is compared to an internal reference voltage. The result of this comparison is available by reading bit **SSTAT2.DSATC**.

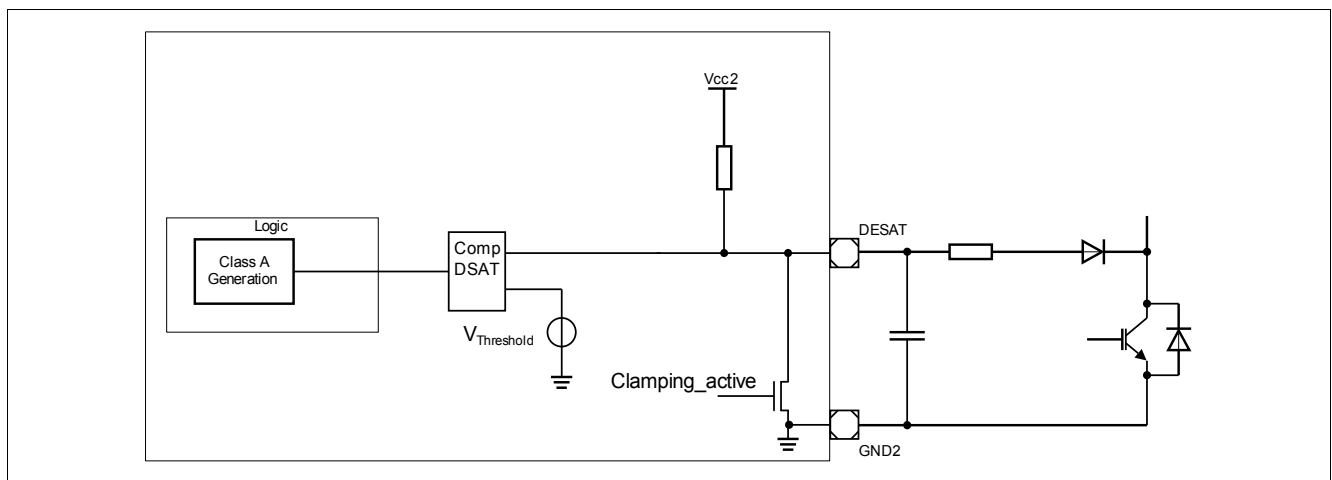

Figure 3-1 DESAT Function: Diagram of Principle

At the beginning of a turn-on sequence, the voltage at pin **DESAT** is forced to Low level for the duration the blanking time defined by register **SDESAT**. Once the blanking time has elapsed, the voltage at pin **DESAT** is released and is compared to an internal reference voltage. Depending on the value of the decoupling capacitance, an additional “analog” blanking time will be added corresponding to the charging of the capacitance through the internal pull-up resistance ([Figure 3-2](#)).

In case the measured voltage is higher than the selected internal threshold, an Emergency (Safe) Turn-Off sequence is initiated, bit **SER.DESATER** is set and a fault notification is issued on pin **NFLTA** (in case of an OPM transition the state machine - see [Chapter 2.4.7](#)). The threshold can be selected in OPM2 during configuration in **SCFG.DSATLS**. Writing 1 to **DSATLS** will select **DESAT Reference Level** V_{DESAT1} otherwise V_{DESAT0} is selected. The DESAT function is not active while the output stage is in PWM OFF state.

The blanking time needs to be chosen carefully, since the DESAT protection may be *de facto* inhibited if the PWM ON-time is too short compared to the chosen blanking time.

At turn-off, the DESAT signal is pulled down for the duration of the TTOFF plateau time, and extended by the blanking time once the hard turn off sequence is initiated.

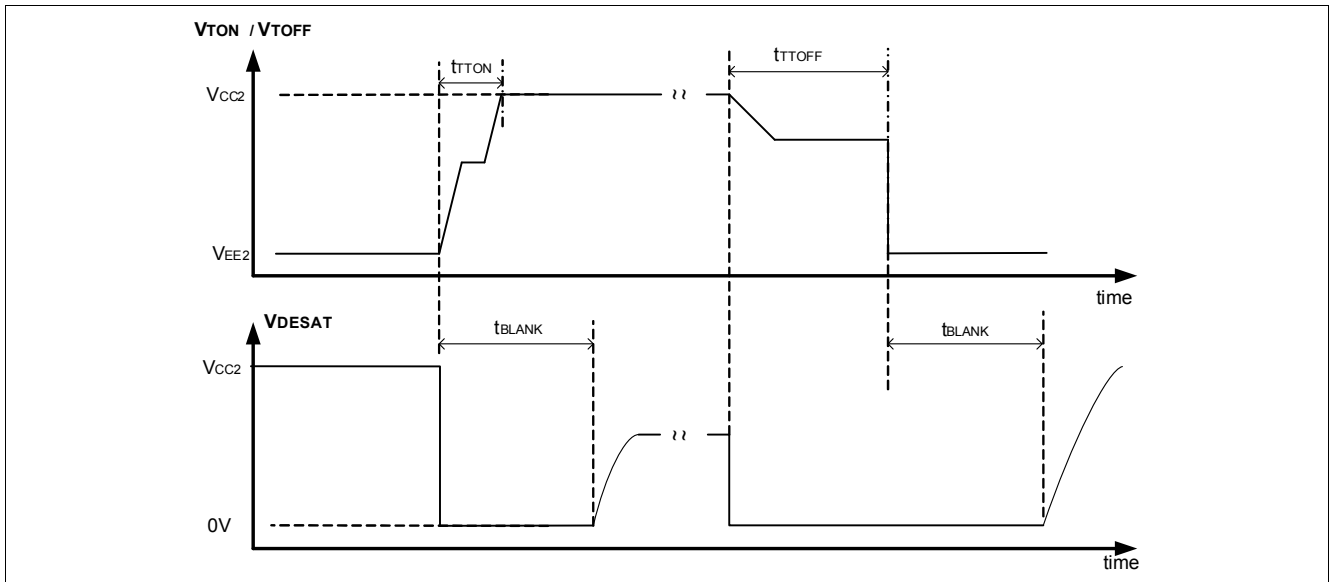

Figure 3-2 DESAT Operation

Note: . In case the **DESAT** pin is open, the pull-up resistance ensures that a DESAT event is generated at the next PWM turn-on command.

DESAT Clamping during turn-off

The internal pull-up resistance may lead to the unwanted charging of the DC-link capacitance via the DESAT pin. In order to overcome this, the DESAT function needs to be activated by clearing bit **SCFG.DSTCEN**. When this bit is set, pin **DESAT** is internally clamped to GND2 when a PWM OFF command is issued by the device.

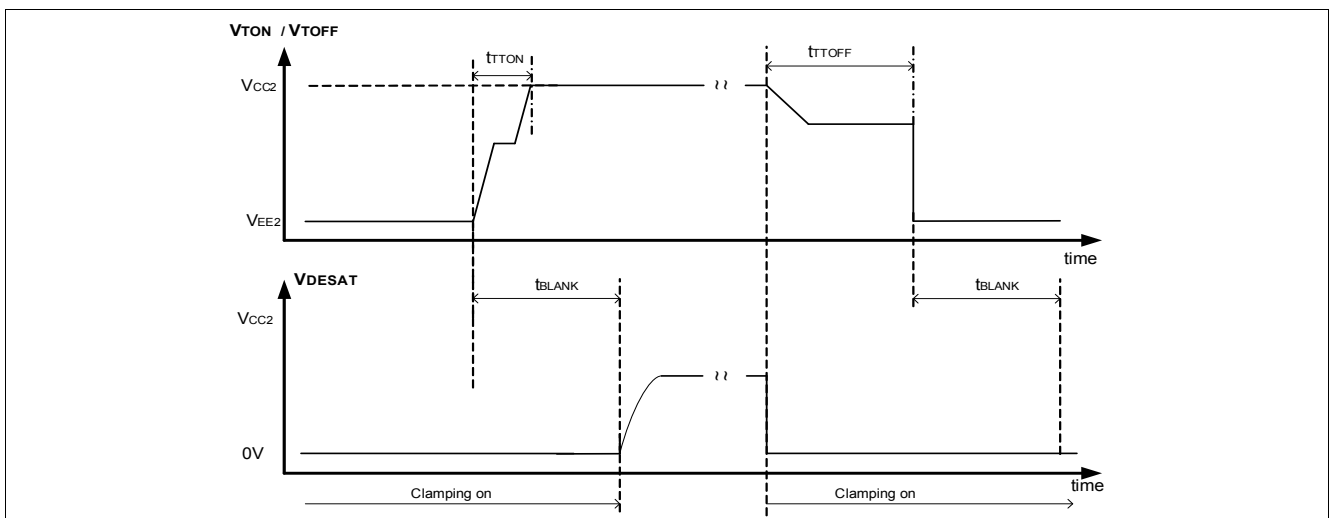

Figure 3-3 DESAT Operation with DESAT clamping enabled

3.2.2 Overcurrent Protection

The integrated Over Current Protection (OCP) functionality is summarized in [Table 3-3](#):

Table 3-3 OCP Function Overview

Parameter	Short Description
Function	Monitoring of the voltage drop over an external resistor located on the auxiliary emitter path of the IGBT.
Periodicity	Continuous while device issues a PWM ON command.
Action in case of failure event	<ol style="list-style-type: none"> 1. Emergency (Safe) Turn-off Sequence. 2. Error Flag SER.OCPER is set. 3. Assertion of signal NFLTA.
Programmability	Yes (blanking time and threshold level).

The integrated Over Current Protection (OCP) function aims at protecting the IGBT in case of overcurrent and short-circuit conditions. The voltage drop over a sense resistor located on the auxiliary emitter path of the IGBT is monitored via the **OCP** while the device issues a PWM ON command. The voltage at pin **OCP** is externally filtered by an (optional) RC filter and compared to the internal reference threshold (see [Figure 3-4](#)). The result of these comparisons is available by reading bits **SSTAT2.OCP**.

*Note: Bit **SSTAT2.OCP** is blanked by the selected blanking time.*

At the beginning of a turn-on sequence, the internal evaluation of the voltage at pin **OCP** is inhibited for the duration the blanking time defined by register **SOCP**. Once the blanking time has elapsed, the voltage at pin **OCP** is compared to an internal reference voltage.

In case the measured voltage at pin **OCP** is higher than the internal threshold V_{OCP} , an Emergency (Safe) Turn-off sequence is initiated, bit **SER.OCPER** is set and a fault notification is issued on pin **NFLTA** (in case of an OPM transition the state machine - see [Chapter 2.4.7](#)). The OCP function is not active while the output stage is in PWM OFF state. The detection threshold can be selected by configuring bit field **SCFG.OCLPS**.

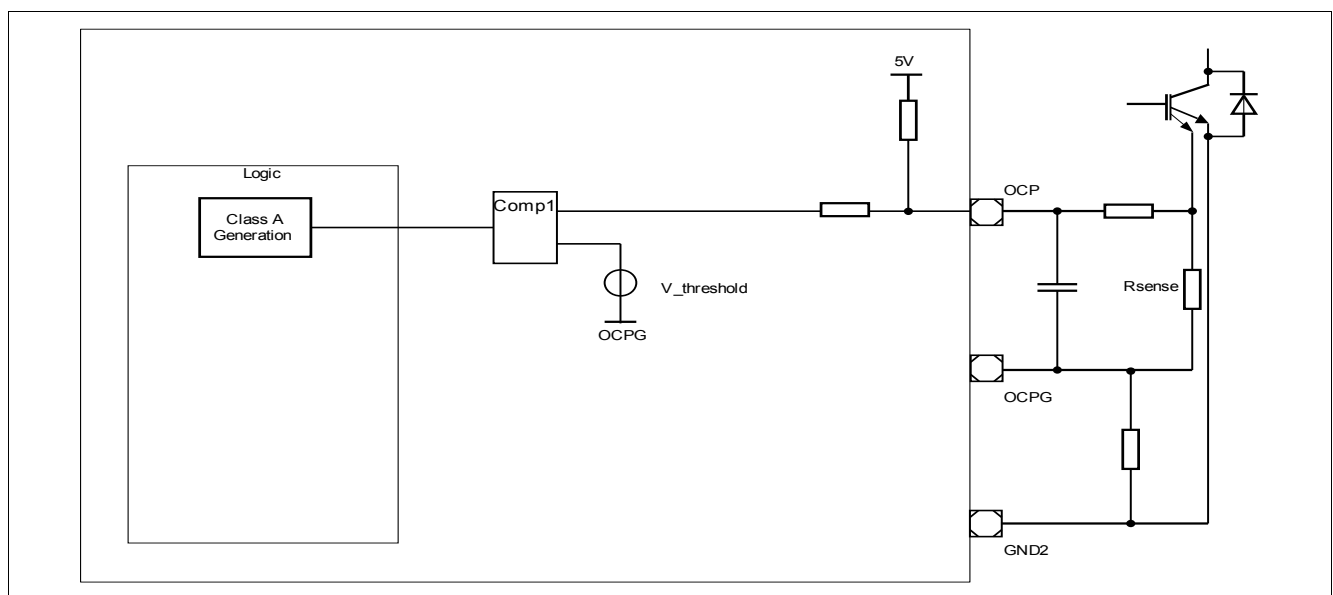

Figure 3-4 OCP Function: Principle of Operation

Note:

1. Both **DESAT** and **OCP** protection mechanisms can be used simultaneously.
2. In case the **OCP** pin is open, the pull-up resistance ensures that an **OCP** event is generated.

3. If *TLTO* or *TLTOFF* times are used, these times should be taken into consideration for the blanking time as well to reach valid voltage levels.

3.2.3 External Enable

The External Enable functionality is summarized in [Table 3-4](#):

Table 3-4 External Enable Function Overview

Parameter	Short Description
Function	External Enable.
Periodicity	Invalid signal on EN pin.
Action in case of failure event	<ol style="list-style-type: none"> 1. Emergency (Regular) Turn-off Sequence. 2. Error Flag PER.ENER is set. 3. Assertion of signal NFLTA.
Programmability	No.

The functionality of the signal at pin **EN** is given in [Chapter 2.4.8](#). In case of a Valid-to-Invalid signal transition, an error is detected. In this case, an Emergency (Regular) turn-off sequence is initiated, bit **PER.ENER** is set and a fault notification is issued on pin **NFLTA** (in case of an OPM transition the state machine - see [Chapter 2.4.7](#)). The current validity state of the signal at pin **EN** can be read on bit **PSTAT2.ENVAL**.

3.3 Protection Functions: Category B

3.3.1 Power Supply Voltage Monitoring

The Power Supply Voltage Monitoring functionality is summarized in [Table 3-5](#):

Table 3-5 Power Supply Voltage Monitoring Overview

Parameter	Short Description
Function	Monitoring of V_{CC1} , V_{CC2} .
Periodicity	Continuous.
Action in case of failure event	<ol style="list-style-type: none"> Emergency (Regular) Turn-off Sequence. Error Flag PER.RSTP (UVLO1) or SER.UVLO2ER (UVLO2). Assertion of signal NRST/RDY (UVLO1) or NFLTB (UVLO2).
Programmability	Yes(UVLO2 threshold level).

In order to ensure a correct switching of the IGBT, the device supports an undervoltage lockout (UVLO) function for V_{CC1} and V_{CC2} .

The V_{CC1} voltage is compared (using an internal voltage comparator) to an internal reference threshold. If the power supply voltage V_{CC1} of the primary chip drops below V_{UVLO1L} , an error is detected. In this case, an emergency (Regular) turn-off sequence is initiated and signal **NRST/RDY** goes low. In case V_{CC1} reaches afterwards a level higher than V_{UVLO1H} , then the error condition is removed and signal **NRST/RDY** is deasserted. Besides, bit **PER.RSTP** is set.

The V_{CC2} voltage is compared (using an internal voltage comparator) to an internal reference threshold. If the power supply voltage V_{CC2} of the secondary chip drops below V_{UVLO2L} , an error is detected. In this case, an emergency (Regular) turn-off sequence is initiated, bit **SER.UVLO2ER** is set and signal **NFLTB** is activated (in case of an OPM transition the state machine - see [Chapter 2.4.7](#)). In case V_{CC2} reaches afterwards a level higher than V_{UVLO2H} , then the error condition is removed and the device can be reenabled. The level of UVLO2 can be adjusted via configuration of **SCFG.UVLO2S** to fit lower supply voltage.

The current status of the error detection of UVLO2 mechanism is available by reading bit **SSTAT2.UVLO2M**.

Note: In case V_{CC2} goes below the voltage V_{RST2} , the secondary chip is kept in reset state.

3.4 Protection Functions: Category C

3.4.1 Shoot Through Protection function

The Shoot Through Protection (STP) functionality is summarized in [Table 3-6](#):

Table 3-6 STP Overview

Parameter	Short Description
Function	Prevents both High-Side and Low-Side Switches to be activated simultaneously.
Periodicity	Continuous.
Action in case of failure event	1. The signal at pin INP is inhibited. 2. Error Flag PER.STPER is set.
Programmability	No.
Programmability	Yes (minimum dead time).

With the implemented STP function, a low-side (resp. high-side) device is able to monitor the status of its high-side (resp. low-side) counterpart. The input pin **INSTP** provides an input for the PWM signal of the driver's counterpart ([Figure 3-5](#)).

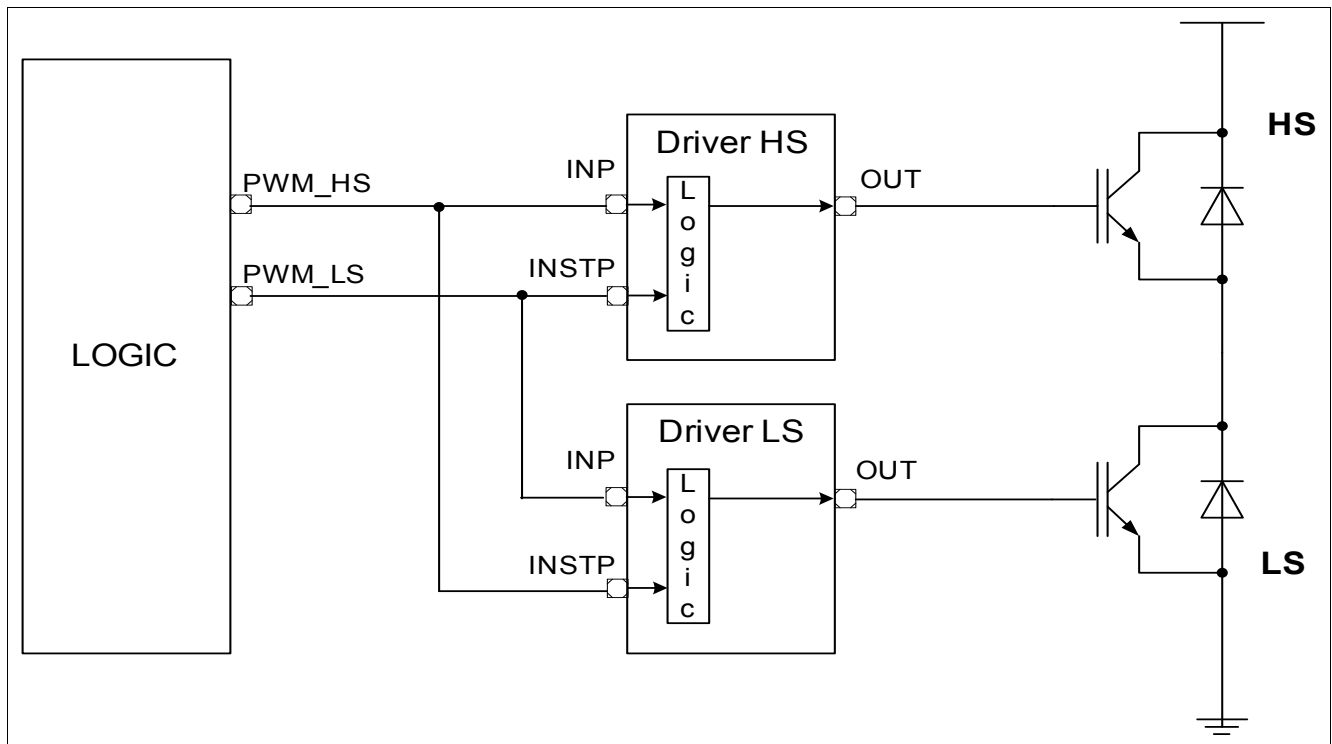

Figure 3-5 Shoot Through Protection: Principle of Operation

In case one of the driver is in ON state, the driver's counterpart PWM input is inhibited, preventing it to turn-on (See [Chapter 2.4.3](#)). A minimum dead time is defined by hardware. This dead time is programmable via bit field **PCFG2.STPDEL**. Conceptually, the STP aims at providing an additional "line of defense" for the system in case erroneous PWM commands are issued by the primary logic. In normal operation, dead time management shall be performed at the microcontroller level.

In case a PWM ON command is received on pin **INP** during the inhibition time, a failure event is detected. In this case, the high level at pin **INP** is ignored and bit **PER.STPER** is set.

Note: Internal filter ensures that STPER is not set for glitches smaller than approximately 50ns.

The STP can be tested by applying non valid INSTP and INP and by checking bit **PSTAT2.STP**.

The STP can not be disabled. However, setting pin **INSTP** to V_{GND1} deactivates de facto the function.

3.4.2 SPI Error Detection

The SPI Error Detection mechanisms are summarized in **Table 3-7**:

Table 3-7 SPI Error Detection Overview

Parameter	Short Description
Function	Non valid SPI command detection and notification.
Periodicity	Continuous.
Action in case of failure event	Flag PER.SPIER is set.
Programmability	Yes (parity can be disabled).

For more details, see **Chapter 2.4.4.4**.

The SPI Error Detection Mechanism can be tested by inserting on purpose a dedicated error and by verifying that the device's reaction is conform to specification.

3.5 Protection Functions: Category D

3.5.1 Operation in Verification Mode and Weak Active Mode

Verification Mode and Weak Active Mode are used to start intrusive test functions on device and system level, in order to verify during life time safety relevant functions. The following functions are supported in Verification and Weak Active Mode:

- Weak Turn-On
- Internal Clock Supervision
- Timing Calibration Feature

Intrusive test functions can only be started once a correct sequence of SPI commands has been received after reset. The implementation of the device ensures that no intrusive function can be started when the device is normally active.

A time-out function ensures that the device quits OPM5 or OPM6 to OPM1 after a hardware defined time.

The verification functions are triggered by setting the corresponding bit fields in registers **PSCR** or **SSCR** in OPM2. The settings are then activated in OPM5. Only one verification function should be activated at the time.

*Note: In OPM5 and OPM6 mode, it is recommended to have bit field **SSTOF.STVAL** programmed to 0_H .*

3.5.2 Weak Turn On

The Weak-Turn On (WTO) corresponds to the operation when Mode OPM6 is active.

The purpose of the Weak Turn-On functionality is to perform a “probe” test of the IGBT, by switching it on with a reduced gate voltage, in order to limit the current through it in case of overcurrent conditions. This allows to avoid high currents when the system has no memory of the previous state.

In Mode OPM6, when the driver initiates a turn-on sequence after the reception of a PWM command, the ON voltage at signal **TON** is defined by bit field **SCTRL.GPONS**. **Figure 3-6** shows an idealized weak turn-on sequence.

The device allows for external booster voltage compensation at the IGBT gate. When bit **SCFG.VBEC** is cleared, the voltage at **TON** at the plateau corresponds to the programmed value. When bit **SCFG.VBEC** is set, an additional V_{BE} (base emitter junction voltage of an internal pn diode) is subtracted to the programmed voltage at **TON** in order to compensate for the V_{BE} of an external booster.

Note: When using WTO, it is recommended to have the selected TTOFF (if active) plateau at a smaller voltage than the WTO voltage.

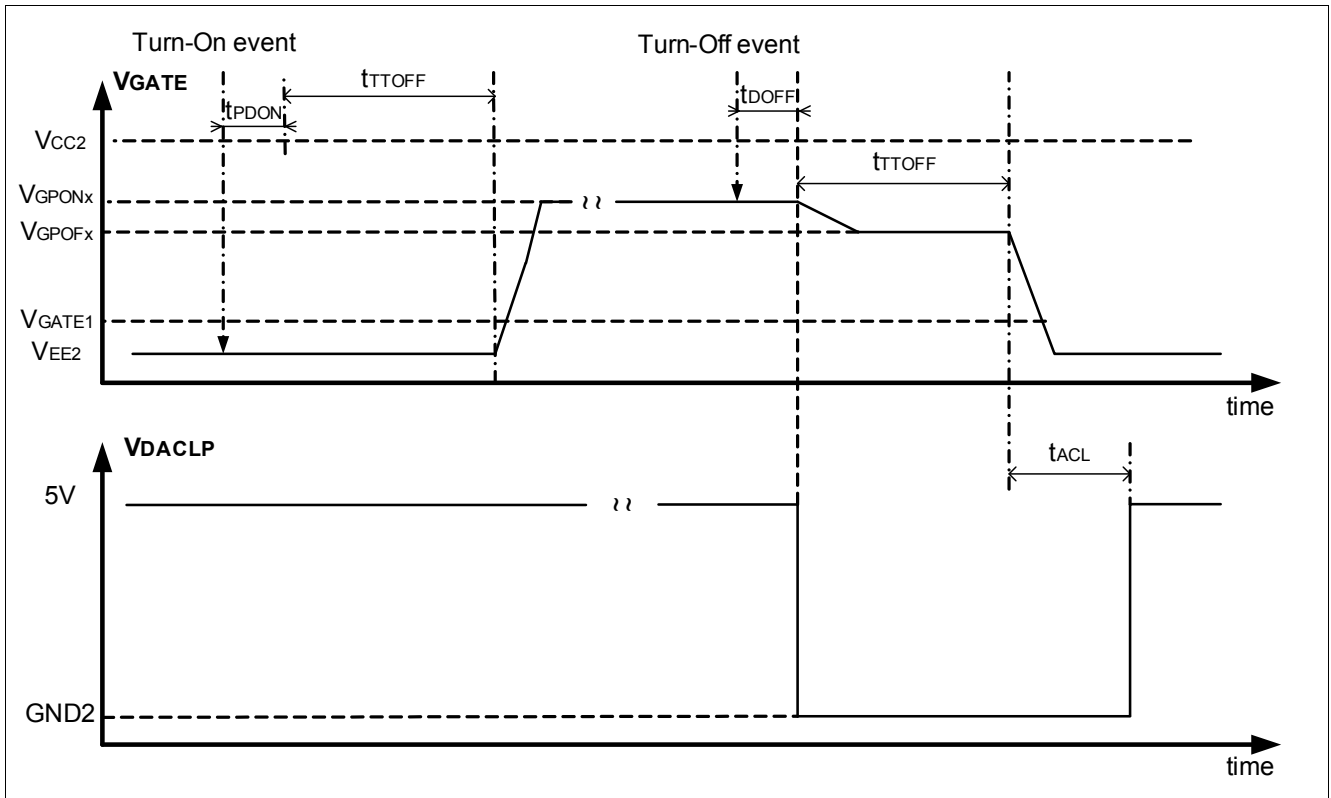

Figure 3-6 Idealized Weak Turn-On Sequence

Note: V_{GPOFx} have to be smaller as V_{GPONx} to get a lower plateau.

3.5.3 Internal Clock Supervision

The Primary Clock Supervision functionality is summarized in [Table 3-8](#):

Table 3-8 Primary Clock Supervision Overview

Parameter	Short Description
Function	Supervision of the frequency of OSC1 and SSOSC2.
Periodicity	On Request.
Action in case of event	N.a.
Programmability	No

The clock supervision function consists on the primary clock supervision and the TCF feature.

Primary Clock Supervision

The purpose of this supervision function is to measure the frequency the oscillator OSC1. This function works in such a way that the PWM input signal is used to start and stop a counter clocked by OSC1. The function is activated when the device is in OPM5 or OPM6. The counter is incremented for the duration of the High level at pin **INP**. At a High-to-Low transition at pin **INP**, the counter is stopped, and its content is transferred to bit field **PCS.CSP**. A plausibility check can therefore be made by the logic. In case of a long **INP** pulse, the counter does not overflow but stays at the maximum value until cleared. **PCS.CSP** is cleared by setting bit **PCTRL.CLRP**.

The **INP** signal is not issued at the output stage.

Note: OSC2 is indirectly monitored by the Life Sign mechanism.

Timing Calibration Feature

The purpose of this function is to measure the frequency of oscillator SSOC2. The PWM input signal is used to start and stop a counter clocked by SSOSC2. The function is activated when the device is in OPM6 (only). The counter is incremented for the duration of the High level at pin **INP**. At a High-to-Low transition at pin **INP**, the counter is stopped, and its content is transferred to bit field **SCS.SCSS**. A plausibility check can therefore be made by the logic. In case of a long **INP** pulse, the counter does not overflow but stays at the maximum value until cleared. **SCS.SCSS** is cleared by a reset event or verification mode time out.

The **INP** signal is not issued at the output stage.

4 Register Description

This chapter describes the internal registers of the device. [Table 4-2](#) provides an overview of the implemented registers. The abbreviations shown in [Table 4-3](#) are used in the whole section.

Table 4-1 Register Address Space

Module	Base Address	End Address	Note
SPI	00 _H	1F _H	

Table 4-2 Register Overview

Register Short Name	Register Long Name	Offset Address	Wakeup Value	Reset Value
Register Description,		Primary Register Description		
PID	Primary ID Register	00 _H	n.a.	4911 _H
PSTAT	Primary Status Register	01 _H	n.a.	0F54 _H
PSTAT2	Primary Second Status Register	02 _H	n.a.	0010 _H
PER	Primary Error Register	03 _H	n.a.	x80x _H
PCFG	Primary Configuration Register	04 _H	n.a.	0004 _H
PCFG2	Primary Second Configuration Register	05 _H	n.a.	0045 _H
PCTRL	Primary Control Register	06 _H	n.a.	001C _H
PCTRL2	Primary Second Control Register	07 _H	n.a.	0015 _H
PSCR	Primary Supervision Function Control Register	08 _H	n.a.	0001 _H
PRW	Primary Read/Write Register	09 _H	n.a.	0001 _H
PPIN	Primary Pin Status Register	0A _H	n.a.	0xxx _H
PCS	Primary Clock Supervision Register	0B _H	n.a.	0001 _H
Register Description,		Secondary Registers Description		
SID	Secondary ID Register	10 _H	n.a.	8921 _H
SSTAT	Secondary Status Register	11 _H	n.a.	0001 _H
SSTAT2	Secondary Second Status Register	12 _H	n.a.	0xxx _H
SER	Secondary Error Register	13 _H	n.a.	xxxx _H
SCFG	Secondary Configuration Register	14 _H	n.a.	C111 _H
SCFG2	Secondary Second Configuration Register	15 _H	n.a.	0800 _H
SSCR	Secondary Supervision Function Control Register	17 _H	n.a.	0001 _H
SDESAT	Secondary DESAT Blanking Time Register	18 _H	n.a.	2000 _H
SOCP	Secondary OCP Blanking Time Register	19 _H	n.a.	0001 _H

Table 4-2 Register Overview (cont'd)

Register Short Name	Register Long Name	Offset Address	Wakeup Value	Reset Value
SRTTOF	Secondary Regular TTOFF Configuration Register	1A _H	n.a.	0001 _H
SSTTOF	Secondary Safe TTOFF Configuration Register	1B _H	n.a.	2081 _H
STTON	Secondary TTON Configuration Register	1C _H	n.a.	0001 _H
SADC	Secondary ADC Result Register	1D _H	n.a.	0001 _H
SBC	Secondary ADC Boundary Register	1E _H	n.a.	FC01 _H
SCS	Secondary Clock Supervision Register	1F _H	n.a.	0001 _H

The registers are addressed wordwise.

Table 4-3 Bit Access Terminology

Mode	Symbol	Description
Basic Access Types		
read/write	rw	This bit or bit field can be written or read.
read	r	This bit or bit field is read only.
write	w	This bit or bit field is write only (read as 0 _H).
read/write hardware affected	rwh	As rw, but bit or bit field can also be modified by hardware.
read hardware affected	rh	As r, but bit or bit field can also be modified by hardware.
sticky	s	Bits with this attribute are “sticky” in one direction. If their reset value is once overwritten they can be switched again into their reset state only by a reset operation. Software and internal logic (except reset-like functions) cannot switch this type of bit into its reset state by writing directly the register. The sticky attribute can be combined to other functions (e.g. ‘rh’).
Reserved / not implemented	0	Bit fields named ‘0’ indicate not implemented functions. They have the following behavior: <ul style="list-style-type: none"> • Reading these bit fields returns 0_H. • Writing these bit fields has no effect. These bit fields are reserved. When writing, software should always set such bit fields to 0 _H in order to preserve compatibility with future products.
Reserved / not defined	Res	Certain bit fields or bit combinations in a bit field can be marked as ‘Reserved’, indicating that the behavior of the device is undefined for that combination of bits. Setting the register to such an undefined value may lead to unpredictable results. When writing, software must always set such bit fields to legal values.

4.1 Primary Register Description

Primary ID Register

This register contains the identification number of the primary chip version.

PID	Offset	Wakeup Value	Reset Value
Primary ID Register	00 _H	n.a.	4911 _H

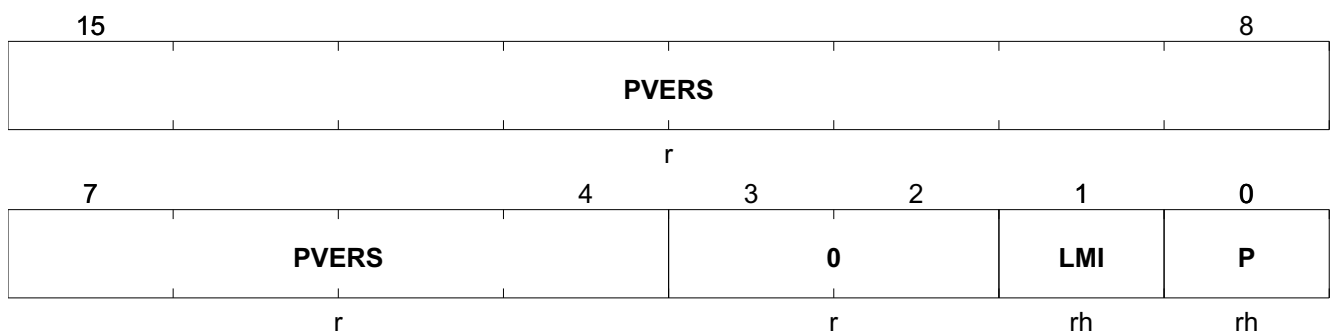

Field	Bits	Type	Description
PVERS	15:4	r	Primary Chip Identification This bit field defines the version of the primary chip. This bit field is hard-wired. 491 _H a11 A11 Step.
0	3:2	r	Reserved Read as 0 _B .
LMI	1	rh	Last Message Invalid Notification This bit indicates if the last received SPI Message was correctly processed by the device. 0 _B Previous Message was processed correctly. 1 _B Previous Message was discarded.
P	0	rh	Parity Bit Odd Parity Bit.

Primary Status Register

This register contains information on the status of the device.

PSTAT	Offset	Wakeup Value	Reset Value
Primary Status Register	01 _H	n.a.	0F54 _H

15	12	11	10	8		
0		ERR	GPONP			
r		rh	rh			
7	6	5	4	2	1	0
ACT	SRDY	AVFP	GPOFP		LMI	P
rh	rh	rh	rh		rh	rh

Field	Bits	Type	Description
0	15:12	r	Reserved Read as 0 _B .
ERR	11	rh	Error Status This bit is the OR combination of all bits of register PER . 0 _B noError No error is detected. 1 _B error An error is detected.
GPONP	10:8	rh	Gate TTON Plateau Level Configuration Status This bit field indicates the latest turn-on plateau level configuration request (WTO, TTON) received by the primary side via the SPI interface. Coding is identical to bit field PCTRL.GPON .
ACT	7	rh	Active State Status This bit indicates if the device is in Active State (OPM4). 0 _B notActive The device is not in Active State. 1 _B active The device is in Active State.
SRDY	6	rh	Secondary Ready Status This bit indicates if the secondary chip is ready for operation. 0 _B notReady Secondary chip is not ready. 1 _B ready Secondary chip is ready.
AVFP	5	rh	ADC Result Valid Flag This bit field indicates if a valid ADC result is available in SADC . <i>Note: This bit field is a mirror of SADC.AVFS</i>

Register Description

Field	Bits	Type	Description
GPOFP	4:2	rh	<p>Gate Regular TTOFF Plateau Level Configuration Status</p> <p>This bit field indicates the latest turn-off plateau level configuration request (regular TTOFF) received by the primary side via the SPI interface. Coding is identical to bit field PCTRL2. GPOF.</p>
LMI	1	rh	<p>Last Message Invalid Notification</p> <p>This bit indicates if the last received SPI Message was correctly processed by the device.</p> <p>0_B Previous Message was processed correctly. 1_B Previous Message was discarded.</p>
P	0	rh	<p>Parity Bit</p> <p>Odd Parity Bit.</p>

Primary Second Status Register

This register contains information on the status of the device.

PSTAT2	Offset	Wakeup Value	Reset Value
Primary Second Status Register	02 _H	n.a.	0010 _H

15	12	11	10	9	8
0		AXVP	STP	FLTBP	FLTAP
r		rh	rh	rh	rh
7	5	4	3	2	1
	OPMP	FLTBP	FLTA	ENVAL	LMI
	rh	rhs	rhs	rh	rh

Field	Bits	Type	Description
0	15:12	r	Reserved Read as 0 _B .
AXVP	11	rh	ADC Under Or Overvoltage Error Status This bit indicates if a boundary condition violation is occurring. <i>Note: This bit is a mirror of the OR combination of bits SADC.AUVS and SADC.AOVS</i> 0 _B noError An error condition is not detected. 1 _B error An error condition is being detected
STP	10	rh	Shoot Through Protection Status This bit is set in case the shoot through protection inhibition time (i.e. would inhibit a PWM rising edge). 0 _B inhibitionNotActive STP inhibition is not active. 1 _B inhibitionActive STP inhibition is active.
FLTBP	9	rh	Event Class B Status This bit indicates if the conditions leading to an event Class B are met. <i>Note: This bit is a mirror of bit SSTAT.FLTBS</i> 0 _B noError No error condition detected. 1 _B error An error condition is detected.
FLTAP	8	rh	Event Class A Status This bit indicates if the conditions leading to an event Class A are met. <i>Note: This bit is a mirror of bit SSTAT.FLTAS</i> 0 _B noError No error condition is detected. 1 _B error An error condition is detected.

Register Description

Field	Bits	Type	Description
OPMP	7:5	rh	<p>Operating Mode This bit field indicates which operating mode is active. <i>Note: This bit field is a mirror of bit field SSTAT.OPMS</i></p> <p>000_B opm0 Mode OPM0 is active . 001_B opm1 Mode OPM1 is active . 010_B opm2 Mode OPM2 is active. 011_B opm3 Mode OPM3 is active. 100_B opm4 Mode OPM4 is active. 101_B opm5 Mode OPM5 is active. 110_B opm6 Mode OPM6 is active. 111_B Reserved.</p>
FLTB	4	rhs	<p>NFLTB Pin Driver Request This bit indicates what output state is driven by the device at pin NFLTB. This bit is sticky. 0_B tristate NFLTB is in tristate. 1_B lowLevel A Low Level is issued at NFLTB.</p>
FLTA	3	rhs	<p>NFLTA Pin Driver Request This bit indicates what output state is driven by the device at pin NFLTA. This bit is sticky. 0_B tristate NFLTA is in tristate. 1_B lowLevel A Low Level issued at NFLTA.</p>
ENVAL	2	rh	<p>EN Valid Status This bit indicates if the signal received on pin EN is valid. 0_B notValid A non-valid signal is detected. 1_B valid A valid signal is detected.</p>
LMI	1	rh	<p>Last Message Invalid Notification This bit indicates if the last received SPI Message was correctly processed by the device. 0_B Previous Message was processed correctly. 1_B Previous Message was discarded.</p>
P	0	rh	<p>Parity Bit Odd Parity Bit.</p>

Primary Error Register

This register provides information on the error status of the device.

PER		Offset		Wakeup Value		Reset Value	
Primary Error Register		03 _H		n.a.		x80x _H	
15	13	12	11	10	9	8	
	0	RSTEP	RSTP	ENER	STPER	SPIER	
	r	rhs	rhs	rhs	rhs	rhs	rhs
7	6	5	3	2	1	0	
Res	ADER	0		CERP	LMI	P	
rh	rhs	r		rhs	rh	rh	

Field	Bits	Type	Description
0	15:13	r	Reserved Read as 0 _B .
RSTEP	12	rhs	Primary External Hard Reset flag This bit indicates if a reset event has been detected on the primary chip due to the activation of pin NRST/RDY . This bit is sticky. 0 _B notSet No external hard reset event has been detected. 1 _B set An externally hard reset event has been detected.
RSTP	11	rhs	Primary Reset Flag This bit indicates if a reset event has been detected on the primary chip. This bit is sticky. 0 _B notSet No reset event has been detected. 1 _B set A reset event has been detected.
ENER	10	rhs	EN Signal Invalid Flag This bit indicates if an invalid-to-valid transition on signal EN has been detected. This bit is sticky. <i>Note: This bit can not be cleared while an error condition is active (bit PSTAT2.ENVAL cleared).</i> 0 _B notSet No event has been detected. 1 _B set An event has been detected.

Register Description

Field	Bits	Type	Description
STPER	9	rhs	<p>Shoot Through Protection Error Flag This bit indicates if a shoot through protection error event has been detected. This bit is sticky.</p> <p><i>Note: This bit can not be cleared while an error condition is active (bit PSTAT2.STP set).</i></p> <p>0_B notSet No event has been detected. 1_B set An event has been detected.</p>
SPIER	8	rhs	<p>SPI Error Flag This indicates if an SPI error event has been detected. This bit is sticky.</p> <p>0_B notSet No error event has been detected. 1_B set An error event has been detected.</p>
Res	7	rh	<p>Reserved This bit field is reserved.</p>
ADER	6	rhs	<p>ADC Error Flag This bit indicates if a boundary condition violation has occurred. This bit is sticky.</p> <p><i>Note: This bit can not be cleared while an error condition is active (bit PSTAT2.AXVP set)</i></p> <p>0_B notSet No error condition has been detected. 1_B set An error condition has been detected has been detected.</p>
0	5:3	r	<p>Reserved Read as 0_B.</p>
CERP	2	rhs	<p>Primary Communication Error Flag This indicates if a loss of communication event¹⁾ with the secondary chip has been detected by the primary chip. This bit is sticky.</p> <p><i>Note: This bit can not be cleared while an error condition is active (bit PSTAT2.SRDY cleared).</i></p> <p>0_B notSet No event has been detected. 1_B set An event has been detected.</p>
LMI	1	rh	<p>Last Message Invalid Notification This bit indicates if the last received SPI Message was correctly processed by the device.</p> <p>0_B Previous Message was processed correctly. 1_B Previous Message was discarded.</p>
P	0	rh	<p>Parity Bit Odd Parity Bit.</p>

1) This bit is not set after a reset event

Primary Configuration Register

This register is used to select the configuration of the device.

PCFG	Offset	Wakeup Value	Reset Value
Primary Configuration Register	04 _H	n.a.	0004 _H

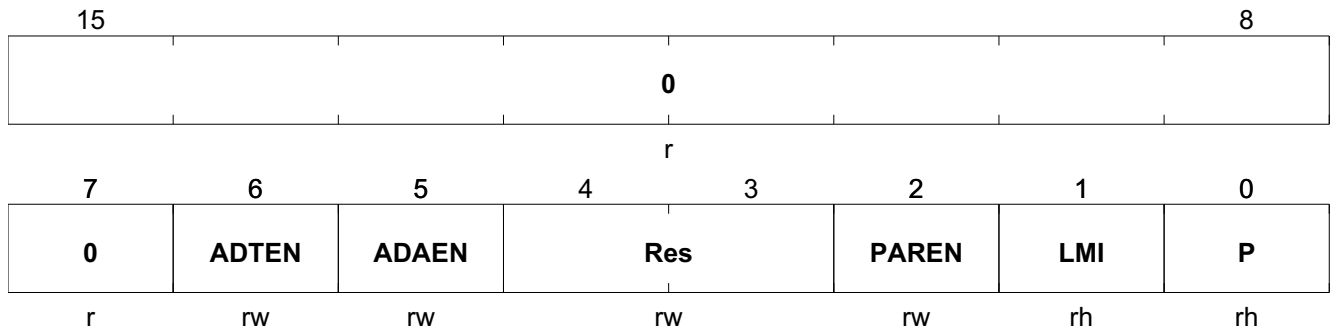

Field	Bits	Type	Description
0	15:7	r	Reserved Read as 0 _B .
ADTEN	6	rw	ADC Trigger Input Enable This bit enables the generation of an ADC trigger in case of a transition from Low to High at pin ADCT . 0 _B disabled ADCT pin is disabled. 1 _B enabled ADCT pin is enabled
ADAEN	5	rw	NFLTA Pin Activation on Boundary Check Event Enable This bit enables the activation of signal NFLTA in case of a transition from 0 _B to 1 _B of bit PSTAT2.AXVP . 0 _B disabled NFLTA activation is disabled. 1 _B enabled NFLTA activation is enabled
Res	4:3	rw	Reserved This bit field is reserved and shall be written with 0 _B .
PAREN	2	rw	SPI Parity Enable This bit indicates if the SPI parity error detection is active (reception only). 0 _B disabled Parity Check is disabled. 1 _B enabled Parity Check is enabled.
LMI	1	rh	Last Message Invalid Notification This bit indicates if the last received SPI Message was correctly processed by the device. 0 _B Previous Message was processed correctly. 1 _B Previous Message was discarded.
P	0	rh	Parity Bit Odd Parity Bit.

Primary Second Configuration Register

This register is used to select the configuration of the device.

PCFG2	Offset	Wakeup Value	Reset Value
Primary Second Configuration Register	05 _H	n.a.	0045 _H

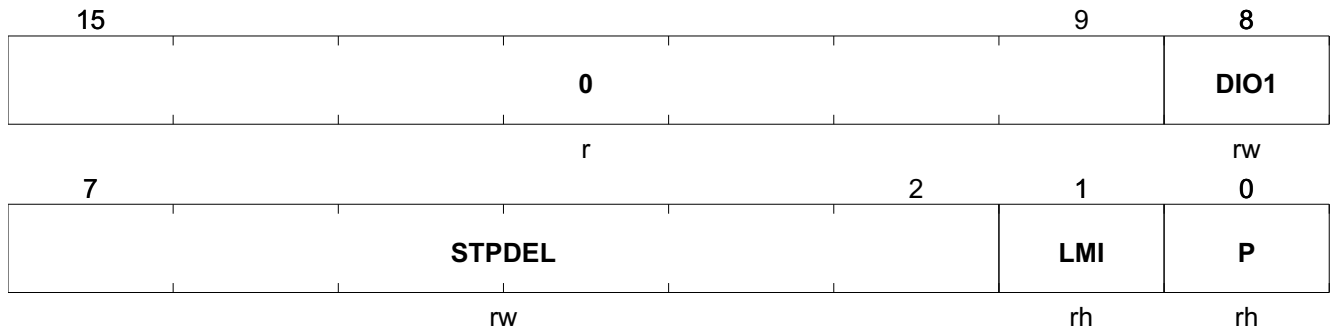

Field	Bits	Type	Description
0	15:9	r	Reserved Read as 0 _B .
DIO1	8	rw	DIO1 Pin Mode This bit field determines the direction of pin DIO1 . 0 _B input DIO1 is an input. 1 _B output DIO1 is an output.
STPDEL	7:2	rw	Shoot Through Protection Delay This bit field determines the dead time for the shoot-through protection (in number of OSC1 clock cycles). 00 _H : 0 clock cycle. ... 01 _H 01 1 clock cycle. 3F _H 3F 63 clock cycles.
LMI	1	rh	Last Message Invalid Notification This bit indicates if the last received SPI Message was correctly processed by the device. 0 _B Previous Message was processed correctly. 1 _B Previous Message was discarded.
P	0	rh	Parity Bit Odd Parity Bit.

Primary Control Register

This register is used to control the device during run-time.

PCTRL	Offset	Wakeup Value	Reset Value
Primary Control Register	06 _H	n.a.	001C _H

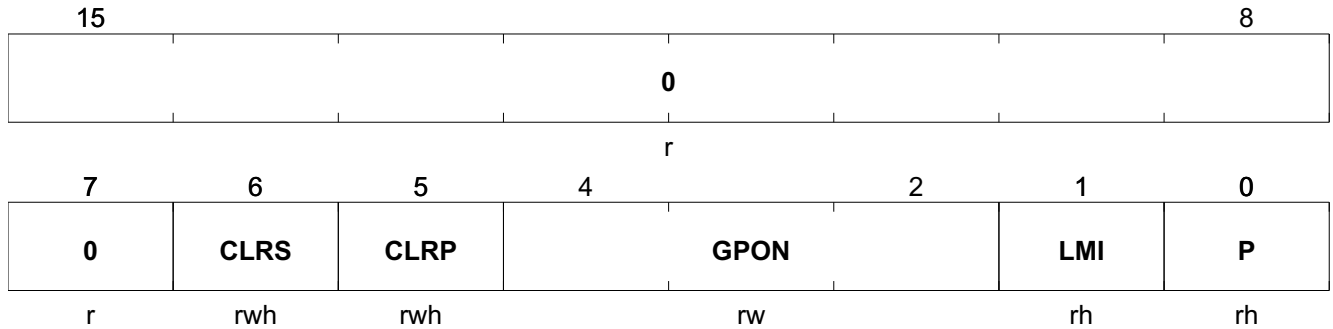

Field	Bits	Type	Description
0	15:7	r	Reserved Read as 0 _B .
CLRS	6	rwh	Clear Secondary Sticky Bits This bit is used to clear the sticky bits on the secondary side. This bit is automatically cleared by hardware. . 0 _B noAction No action. 1 _B clear Clear sticky bits.
CLRP	5	rwh	Clear Primary Sticky Bits This bit is used to clear the sticky bits on the primary side. This bit is automatically cleared by hardware. . 0 _B noAction No action. 1 _B clear Clear sticky bits and deassert signals NFLTA and NFLTb .
GPON	4:2	rw	Gate TTON Plateau Level This bit field is used to configure the voltage of the plateau during Weak Turn-On and Two Level Turn-On. For voltage levels see Table 5-15 . 0 _H gpon0 V _{GPON0} selected. 1 _H gpon1 V _{GPON1} selected. 2 _H gpon2 V _{GPON2} selected. 3 _H gpon3 V _{GPON3} selected. 4 _H gpon4 V _{GPON4} selected. 5 _H gpon5 V _{GPON5} selected. 6 _H gpon6 V _{GPON6} selected. 7 _H gpon6WtoOrHardSwitching V _{GPON6} (WTO) or Hard Switching (TTON).

Register Description

Field	Bits	Type	Description
LMI	1	rh	Last Message Invalid Notification This bit indicates if the last received SPI Message was correctly processed by the device. 0 _B Previous Message was processed correctly. 1 _B Previous Message was discarded.
P	0	rh	Parity Bit Odd Parity Bit.

Primary Second Control Register

This register is used to control the device during run-time.

PCTRL2	Offset	Wakeup Value	Reset Value
Primary Second Control Register	07 _H	n.a.	0015 _H

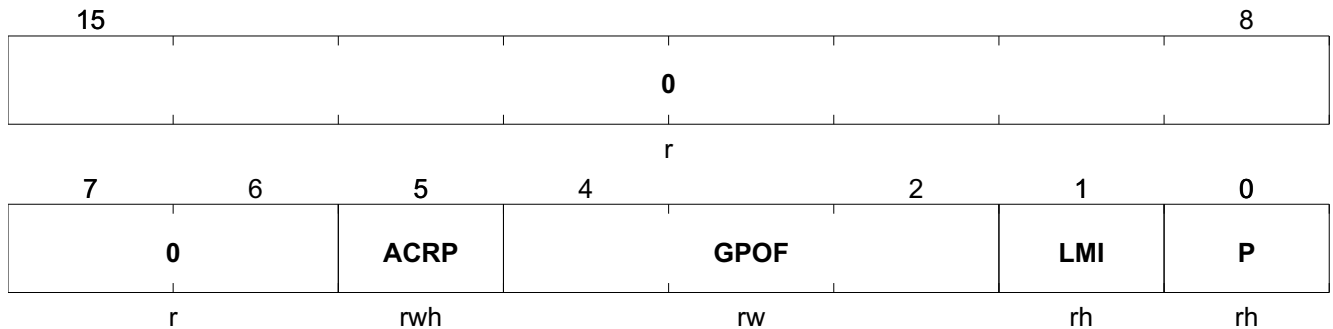

Field	Bits	Type	Description
0	15:6	r	Reserved Read as 0 _B .
ACRP	5	rwh	ADC Conversion Request This bit is used to trigger an ADC conversion. It can be set by a direct write or via pin ADCT . 0 _B none No conversion request pending. 1 _B pending A conversion request is pending. This bit is automatically cleared by hardware
GPOF	4:2	rw	Gate Regular TTOFF Plateau Level This bit field is used to configure the Two-Level Turn-Off plateau voltage (regular turn-off). For voltage levels see Table 5-15 . 0 _H gpof0 V _{GPOF0} selected. 1 _H gpof1 V _{GPOF1} selected. 2 _H gpof2 V _{GPOF2} selected. 3 _H gpof3 V _{GPOF3} selected. 4 _H gpof4 V _{GPOF4} selected. 5 _H gpof5 V _{GPOF5} selected. 6 _H gpof6 V _{GPOF6} selected. 7 _H gpof7 V _{GPOF7} selected.
LMI	1	rh	Last Message Invalid Notification This bit indicates if the last received SPI Message was correctly processed by the device. 0 _B Previous Message was processed correctly. 1 _B Previous Message was discarded.
P	0	rh	Parity Bit Odd Parity Bit.

Primary Supervision Function Control Register

This register is used to trigger the verification functions on the primary side.

PSCR	Offset	Wakeup Value	Reset Value
Primary Supervision Function Control Register	08 _H	n.a.	0001 _H

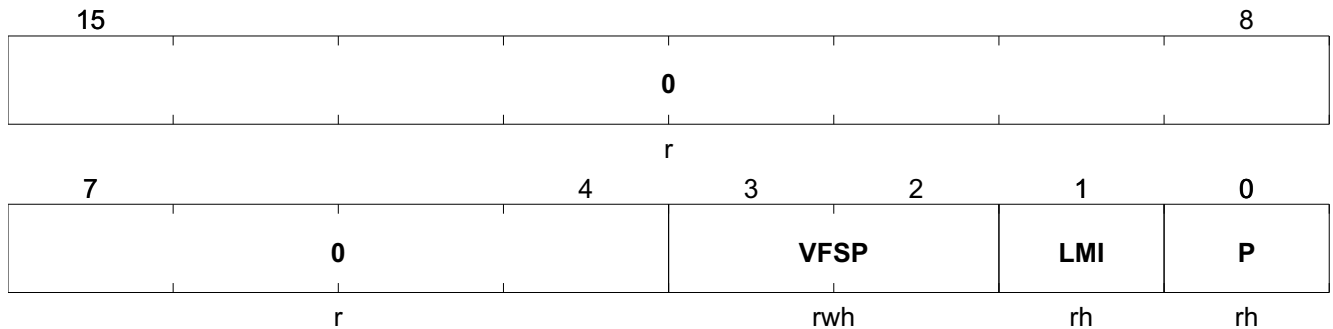

Field	Bits	Type	Description
0	15:4	r	Reserved Read as 0 _B .
VFSP	3:2	rwh	Primary Verification Function This bit field is used to activate the primary verification functions. <i>Note: The selection defined by this bit field is only effective when the device enters Mode OPM5. This bit field is automatically cleared when entering OPM1.</i> 00 _B disabled No function activated. 01 _B Reserved. 10 _B primaryClockSupervision Primary Clock Supervision active. 11 _B Reserved.
LMI	1	rh	Last Message Invalid Notification This bit indicates if the last received SPI Message was correctly processed by the device. 0 _B Previous Message was processed correctly. 1 _B Previous Message was discarded.
P	0	rh	Parity Bit Odd Parity Bit.

Primary Read/Write Register

This register provides a readable and writable address space for data integrity test during runtime. This register is not associated with any hardware functionality.

PRW	Offset	Wakeup Value	Reset Value
Primary Read/Write Register	09 _H	n.a.	0001 _H

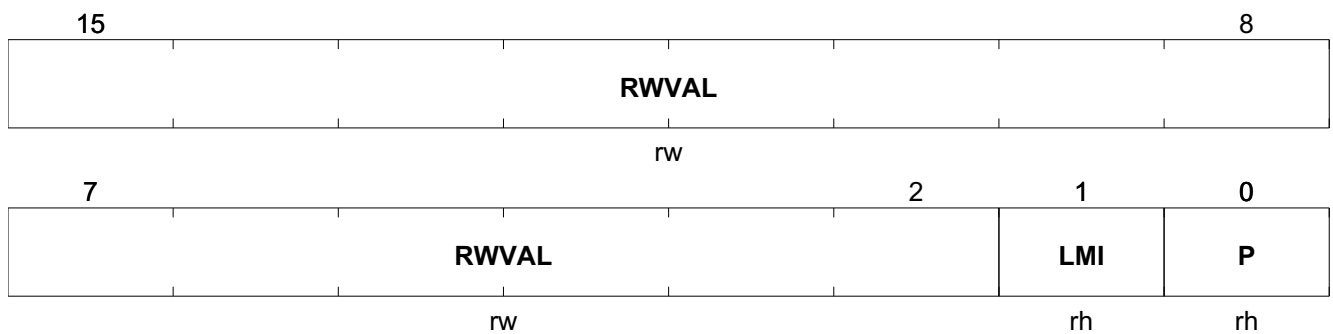

Field	Bits	Type	Description
RWVAL	15:2	rw	Data Integrity Test Register This bit field is “don’t care” for the device.
LMI	1	rh	Last Message Invalid Flag This bit indicates if the last received SPI Message was correctly processed by the device. 0 _B noError Previous Message processed correctly. 1 _B error Previous Message not processed.
P	0	rh	Parity Bit Odd Parity Bit.

Primary Pin Status Register

This register provides status information on the I/Os of the primary chip.

PPIN	Offset	Wakeup Value	Reset Value
Primary Pin Status Register	0A _H	n.a.	0xxx _H

15							9	8
0							DIO1L	
r							rh	
7	6	5	4	3	2	1	0	
ADCTL	NFLTBL	NFLTAL	ENL	INSTPL	INPL	LMI	P	
rh	rh	rh	rh	rh	rh	rh	rh	

Field	Bits	Type	Description
0	15:9	r	Reserved Read as 0 _B .
DIO1L	8	rh	DIO1 Pin Level This bit indicates the logical level read on pin DIO1 . 0 _B low Low-level is detected. 1 _B high High-level is detected.
ADCTL	7	rh	ADC Trigger Input Level This bit indicates the logical level read on pin ADCT . 0 _B low Low-level is detected. 1 _B high High-level is detected.
NFLTBL	6	rh	NFLTBL pin level This bit indicates the logical level read on pin NFLTBL . 0 _B low Low-level is detected. 1 _B high High-level is detected.
NFLTAL	5	rh	NFLTA pin Level This bit indicates the logical level read on pin NFLTA . 0 _B low Low-level is detected. 1 _B high High-level is detected.
ENL	4	rh	EN Pin Level This bit indicates the logical level read on pin EN . 0 _B low Low-level is detected. 1 _B high High-level is detected.
INSTPL	3	rh	INSTP Pin Level This bit indicates the logical level read on pin INSTP . 0 _B low Low-level is detected. 1 _B high High-level is detected.

Register Description

Field	Bits	Type	Description
INPL	2	rh	INP Pin Level This bit indicates the logical level read on pin INP . 0 _B low Low-level is detected. 1 _B high High-level is detected.
LMI	1	rh	Last Message Invalid Notification This bit indicates if the last received SPI Message was correctly processed by the device. 0 _B noError Previous Message was processed correctly. 1 _B error Previous Message was discarded.
P	0	rh	Parity Bit Odd Parity Bit.

Primary Clock Supervision Register

This register shows the result of the Primary Clock Supervision function.

PCS	Offset	Wakeup Value	Reset Value
Primary Clock Supervision Register	0B _H	n.a.	0001 _H

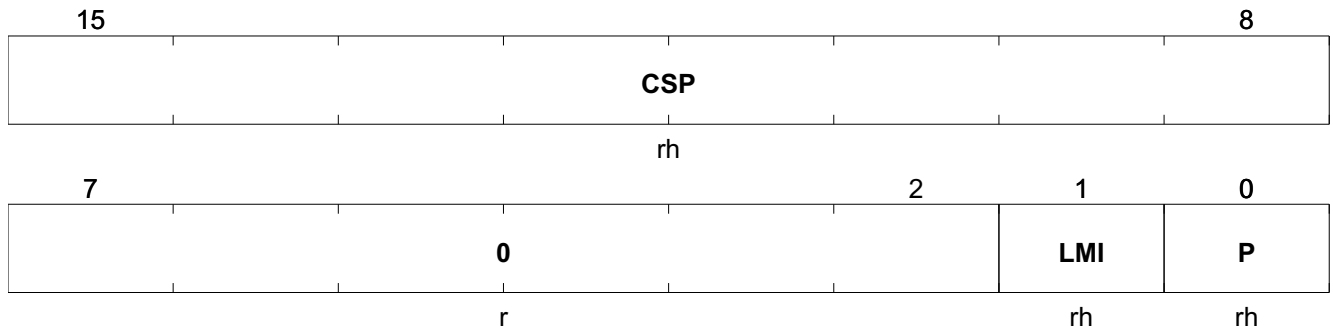

Field	Bits	Type	Description
CSP	15:8	rh	Primary Clock Supervision This bit field is written by hardware by the Primary Clock Supervision function and gives the number of measured OSC1 clock cycles. <i>Note: This bit field can be cleared by setting bit PCTRL.CLRP.</i>
0	7:2	r	Reserved Read as 0 _B .
LMI	1	rh	Last Message Invalid Notification This bit indicates if the last received SPI Message was correctly processed by the device. 0 _B Previous Message was processed correctly. 1 _B Previous Message was discarded.
P	0	rh	Parity Bit Odd Parity Bit.

4.2 Secondary Registers Description

Secondary ID Register

This register contains the identification number of secondary chip version.

SID	Offset	Wakeup Value	Reset Value
Secondary ID Register	10 _H	n.a.	8921 _H

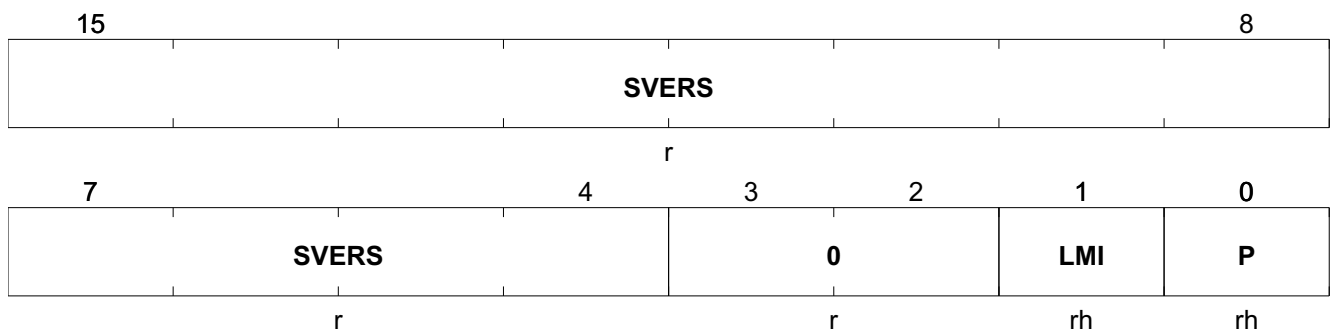

Field	Bits	Type	Description
SVERS	15:4	r	Secondary Chip Identification This bit field defines the version of the secondary chip. This bit field is hard-wired.
0	3:2	r	Reserved Read as 0 _B .
LMI	1	rh	Last Message Invalid Notification This bit indicates if the last received SPI Message was correctly processed by the device. 0 _B Previous Message was processed correctly. 1 _B Previous Message was discarded.
P	0	rh	Parity Bit Odd Parity Bit.

Secondary Status Register

This register contains information on the status of the device.

SSTAT	Offset	Wakeup Value	Reset Value
Secondary Status Register	11 _H	n.a.	0001 _H

Field	Bits	Type	Description
Res	15	rh	Reserved This bit field is reserved.
0	14:11	r	Reserved Read as 0 _B .
DBG	10	rh	Debug Mode Active Flag This bit indicates if the Debug Mode is active. 0 _B notSet Debug Mode is not active. 1 _B set Debug Mode is active.
Res	9:5	rh	Reserved This bit field is reserved.
PWM	4	rh	PWM Command Status This bit indicates the status of the PWM command received from the primary side. 0 _B off PWM OFF command is detected. 1 _B on PWM ON command is detected.
0	3:2	r	Reserved Read as 0 _B .
LMI	1	rh	Last Message Invalid Notification This bit indicates if the last received SPI Message was correctly processed by the device. 0 _B Previous Message was processed correctly. 1 _B Previous Message was discarded.
P	0	rh	Parity Bit Odd Parity Bit.

Secondary Second Status Register

This register contains information on the status of the device.

SSTAT2								Offset	Wakeup Value	Reset Value					
Secondary Second Status Register								12 _H	n.a.	0xxx _H					
15				9				8							
0								DACL							
r								rh							
7		6		5		4		3		2		1		0	
DIO2L		UVLO2M		OCPC		DSATC		0		LMI		P			
rh		rh		rh		rh		r		rh		rh			

Field	Bits	Type	Description
0	15:9	r	Reserved Read as 0 _B .
DACL	8	rh	DACL Pin output level This bit indicates the level read at pin DACL . 0 _B low DACL level is Low. 1 _B high DACL level is High.
DIO2L	7	rh	DIO2 Pin Level This bit indicates the level read at pin DIO2 . 0 _B low DIO2 level is Low. 1 _B high DIO2 level is High.
UVLO2M	6	rh	UVLO2 Event This bit indicates the result of the UVLO2 monitoring function. 0 _B noError No failure condition is detected. 1 _B error One failure condition is detected.
OCPC	5	rh	OCP Comparator Result This bit indicates the (blanked) output of the first comparator of the OCP function. 0 _B belowThreshold OCP voltage is below the internal threshold. 1 _B aboveThreshold OCP voltage is above the internal threshold.
DSATC	4	rh	DESAT Comparator Result This bit indicates the output of the comparator of the DESAT function. 0 _B belowThreshold DESAT voltage is below the internal threshold. 1 _B aboveThreshold DESAT voltage is above the internal threshold.

Register Description

Field	Bits	Type	Description
0	3:2	r	Reserved Read as 0_B .
LMI	1	rh	Last Message Invalid Notification This bit indicates if the last received SPI Message was correctly processed by the device. 0_B Previous Message was processed correctly. 1_B Previous Message was discarded.
P	0	rh	Parity Bit Odd Parity Bit.

Secondary Error Register

This register provides information on the error status of the device.

SER								Offset	Wakeup Value	Reset Value
Secondary Error Register								13 _H	n.a.	xxxx _H
15	14	13	12	11	10	9	8			
RSTS	OCPER	DESATER	UVLO2ER	0	VMTO	0				
rhs	rhs	rhs	rhs	r	rhs	r				
7	6	5	4	3	2	1	0			
0	AOVER	AUVER	CERS	0	LMI	P				
r	rhs	rhs	rhs	r	rh	rh				

Field	Bits	Type	Description
RSTS	15	rhs	<p>Secondary Hard Reset Flag</p> <p>This bit indicates if a hard reset event has been detected on the secondary chip (due to a V_{CC2} power-up). This bit is sticky.</p> <p>0_B notSet No hard reset event has been detected. 1_B set A hard reset event has been detected.</p>
OCPER	14	rhs	<p>OCP Error Flag</p> <p>This bit indicates if an OCP event has been detected. This bit is sticky.</p> <p><i>Note: This bit can not be cleared while an error condition is active (bit SSTAT2.OCP set).</i></p> <p>0_B notSet No event has been detected. 1_B set An event has been detected.</p>
DESATER	13	rhs	<p>DESAT Error Flag</p> <p>This bit indicates if a DESAT event has been detected. This bit is sticky.</p> <p>0_B notSet No event has been detected. 1_B set An event has been detected.</p>
UVLO2ER	12	rhs	<p>UVLO2 Error Flag</p> <p>This bit indicates if an Undervoltage Lockout event (on V_{CC2}) has been detected. This bit is sticky.</p> <p><i>Note: This bit can not be cleared while an error condition is active (bit SSTAT2.UVLO2M set).</i></p> <p>0_B notSet No event has been detected. 1_B set An event has been detected.</p>

Register Description

Field	Bits	Type	Description
0	11:10	r	Reserved Read as 0_B .
VMTO	9	rhs	Verification Mode Time-Out Event Flag This bit indicates if time-out event in Verification Mode has been detected. This bit is sticky. 0_B notSet No event has been detected. 1_B set An event has been detected.
0	8:7	r	Reserved Read as 0_B .
AOVER	6	rhs	ADC Overvoltage Error Flag This bit indicates if a boundary condition violation (overvoltage) occurred. This bit is sticky. 0_B notSet An error condition has not been detected. 1_B set An error condition has been detected.
AUVER	5	rhs	ADC Undervoltage Error Flag This bit indicates if a boundary condition violation (undervoltage) occurred. this bit is sticky. 0_B notSet An error condition has not been detected. 1_B set An error condition has been detected.
CERS	4	rhs	Communication Error Secondary Flag This indicates if a loss of communication event with the primary chip has been detected by the secondary chip. This bit is sticky. 0_B notSet No event has been detected. 1_B set An event has been detected.
0	3:2	r	Reserved Read as 0_B .
LMI	1	rh	Last Message Invalid Notification This bit indicates if the last received SPI Message was correctly processed by the device. 0_B Previous Message was processed correctly. 1_B Previous Message was discarded.
P	0	rh	Parity Bit Odd Parity Bit.

Secondary Configuration Register

This register is used to select the configuration of the device.

SCFG	Offset	Wakeup Value	Reset Value
Secondary Configuration Register	14 _H	n.a.	C111 _H

15	14	13	12	11	10	9	8
DACLC		OCPLS	UVLO2S	DSATLS	TOSEN	PSEN	DSTCEN
rw		rw	rw	rw	rw	rw	rw
7	6	5	4	3	2	1	0
DIO2C		CFG2	VBEC	0		LMI	P
rw		rwh	rw	r		rh	rh

Field	Bits	Type	Description
DACLC	15:14	rw	<p>DACL P Pin clamping output</p> <p>This bit field determines the functionality of pin DACL P.</p> <p>00_B low The pin delivers a constant Low level.</p> <p>01_B high The pin delivers a constant High level.</p> <p>10_B daclpSafe : DACL P function selected. The signal is active only in case of a Safe Turn-Off sequences.</p> <p>11_B daclpRegular : DACL P function selected. The signal is active for both Regular and Safe Turn-Off sequences.</p>
OCPLS	13	rw	<p>OCP Threshold Level</p> <p>This bit field configures the threshold level of the OCP function.</p> <p>0_B vocp0 Threshold V_{OCPO} selected .</p> <p>1_B vocp1 Threshold V_{OCPI} selected .</p>
UVLO2S	12	rw	<p>UVLO2 Threshold Level</p> <p>This bit field configures the threshold level of the UVLO2 function.</p> <p>0_B uvlo2I0 Threshold $V_{UVLO2L0}$ selected .</p> <p>1_B uvlo2I1 Threshold $V_{UVLO2L0}$ selected .</p>
DSATLS	11	rw	<p>DESAT Threshold Level</p> <p>This bit field configures the threshold level of the DESAT function.</p> <p>0_B vdesat0 Threshold V_{DESAT0} selected .</p> <p>1_B vdesat1 Threshold V_{DESAT1} selected .</p>
TOSEN	10	rw	<p>Verification Mode Time Out Duration</p> <p>This bit selects the duration of the verification mode timeout.</p> <p>0_B regular Regular time-out value (typ. 15 ms).</p> <p>1_B slow Slow time-out value (typ. 60 ms).</p>

Register Description

Field	Bits	Type	Description
PSEN	9	rw	Pulse Suppressor Enable This bit enables the internal pulse suppressor. 0 _B disabled Pulse suppressor is disabled. 1 _B enabled Pulse suppressor is enabled.
DSTCEN	8	rw	DESAT Clamping Enable This bit enables the internal clamping (to GND2) of the DESAT pin during PWM OFF commands. 0 _B disabled DESAT clamping is disabled. 1 _B enabled DESAT clamping is enabled.
DIO2C	7:6	rw	DIO2 Pin Mode This bit field determines the functionality of pin DIO2 . 00 _B input DIO2 is an input. 01 _B output DIO2 is an output transferring the signal from DIO1 . 10 _B Reserved. 11 _B Reserved.
CFG2	5	rwh	Secondary Advanced Configuration Enable This bit field enables write accesses to register SCFG2 and SBC . This bit is automatically cleared when mode OPM2 is left. 0 _B disabled Write access to SCFG2 and SBC are discarded. . 1 _B enabled Write access to SCFG2 and SBC are executed normally.
VBEC	4	rw	VBE Compensation Enable This bit enables the V _{BE} compensation of the TTOFF, TTON and WTO plateau levels. 0 _B disabled V _{BE} Compensation disabled. 1 _B enabled V _{BE} Compensation enabled.
0	3:2	r	Reserved Read as 0 _B .
LMI	1	rh	Last Message Invalid Notification This bit indicates if the last received SPI Message was correctly processed by the device. 0 _B Previous Message was processed correctly. 1 _B Previous Message was discarded.
P	0	rh	Parity Bit Odd Parity Bit.

Secondary Second Configuration Register

This register is used to select the configuration of the device. It can only be written if **SCFG.CFG2** is set.

SCFG2	Offset	Wakeup Value	Reset Value
Secondary Second Configuration Register	15 _H	n.a.	0800 _H

15	14	13	12	10	9	8
ADCEN	ACAEN	ACSS	AOS		AGS	
rw	rw	rw	rw		rw	
7	6	5	4	3	2	1
ATS		PWMD		0	LMI	P
rw		rw		r	rh	rh

Field	Bits	Type	Description
ADCEN	15	rw	ADC Enable This bit field enables ADC function: 0 _B disabled ADC Disabled. 1 _B enabled ADC Enabled.
ACAEN	14	rw	ADC Event Class A Enable This bit field enables the generation of Event Class A in case of Boundary Check violation: 0 _B disabled No Event Class A is generated. 1 _B enabled An Event Class A is generated.
ACSS	13	rw	ADC Current Source This bit field activates the internal current source. 0 _B disabled Current source disabled. 1 _B enabled Current source I _{AIPCS} selected.
AOS	12:10	rw	ADC Offset This bit field configures the offset value of the ADC. For voltage levels see Table 5-21 . 0 _H ofst0 V _{OFF0} selected. 1 _H ofst1 V _{OFF1} selected. 2 _H ofst2 V _{OFF2} selected. 3 _H ofst3 V _{OFF3} selected. 4 _H ofst4 V _{OFF4} selected. 5 _H reserved. 6 _H reserved. 7 _H reserved.

Register Description

Field	Bits	Type	Description
AGS	9:8	rw	ADC Gain This bit field configures the gain value of the ADC. 00 _B gain0 GAIN ₀ selected. 01 _B gain1 GAIN ₁ selected. 10 _B gain2 GAIN ₂ selected. 11 _B gain3 GAIN ₃ selected.
ATS	7:6	rw	ADC Secondary Trigger Mode This bit field configures the trigger mode of the ADC on the secondary side. 00 _B disabled No secondary trigger source active. 01 _B periodic Periodic trigger selected. 10 _B risingPwm PWM trigger selected (rising edge). 11 _B fallingPwm PWM trigger selected (falling edge).
PWMD	5:4	rw	ADC PWM Trigger Delay This bit field configures the offset value of the delay between PWM edge and ADC trigger, in case PWM Trigger Mode is selected. 00 _B delay0 16 OSC2 cycles selected. 01 _B delay1 32 OSC2 cycles selected. 10 _B delay2 48 OSC2 cycles selected. 11 _B delay3 64 OSC2 cycles selected.
0	3:2	r	Reserved Read as 0 _B .
LMI	1	rh	Last Message Invalid Notification This bit indicates if the last received SPI Message was correctly processed by the device. 0 _B Previous Message was processed correctly. 1 _B Previous Message was discarded.
P	0	rh	Parity Bit Odd Parity Bit.

Secondary Supervision Function Control Register

This register is used to trigger the verification functions on the secondary side.

SSCR	Offset	Wakeup Value	Reset Value
Secondary Supervision Function Control Register	17 _H	n.a.	0001 _H

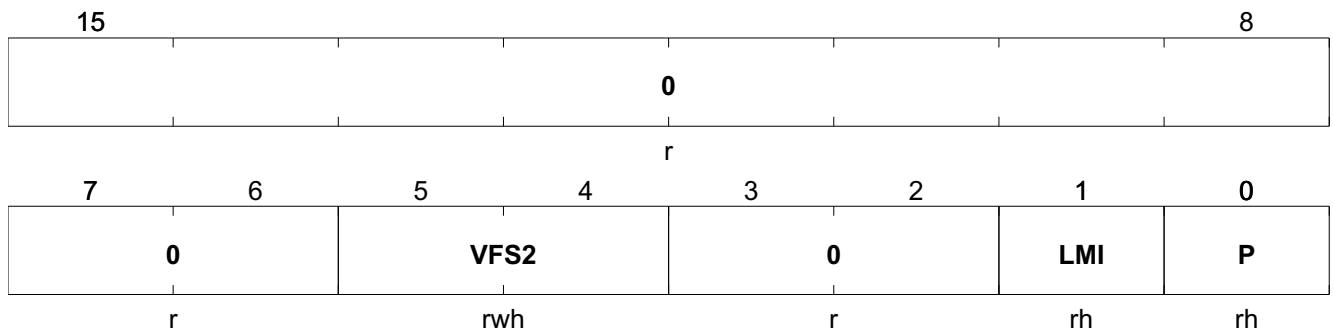

Field	Bits	Type	Description
0	15:6	r	Reserved Read as 0 _B .
VFS2	5:4	rwh	Secondary Verification Function This bit field is used to activate the secondary verification function. All other bit combinations are reserved. <i>Note: The selection defined by this bit field is only effective when the device enters Mode OPM5. This bit field is automatically cleared when entering OPM1.</i> 00 _B disabled No function activated. 01 _B tcf TCF function active.
0	3:2	r	Reserved Read as 0 _B .
LMI	1	rh	Last Message Invalid Notification This bit indicates if the last received SPI Message was correctly processed by the device. 0 _B Previous Message was processed correctly. 1 _B Previous Message was discarded.
P	0	rh	Parity Bit Odd Parity Bit.

Secondary DESAT Blanking Time Register

This register configures the blanking time of the DESAT function.

SDESAT	Offset	Wakeup Value	Reset Value
Secondary DESAT Blanking Time Register	18 _H	n.a.	2000 _H

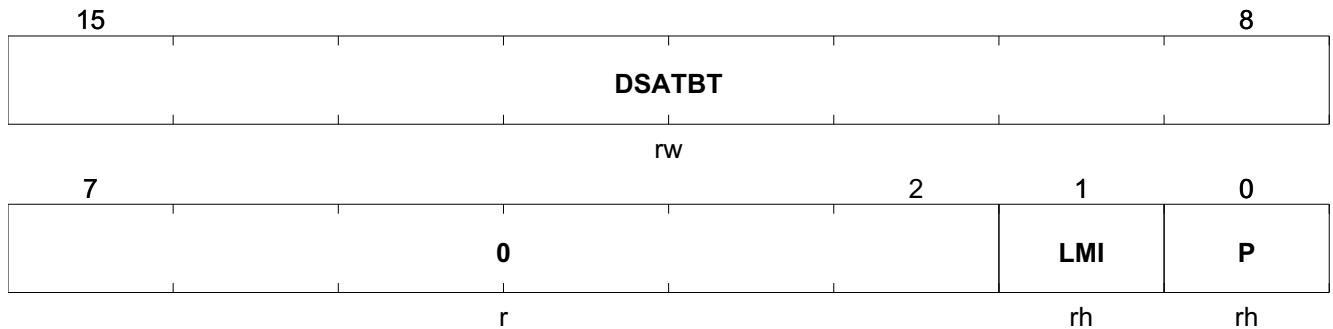

Field	Bits	Type	Description
DSATBT	15:8	rw	DESAT Blanking Time This bit field defines the blanking time of the DESAT function (in OSC2 clock cycles). A minimal value of at least A_H has to be programmed.
0	7:2	r	Reserved Read as 0_B .
LMI	1	rh	Last Message Invalid Notification This bit indicates if the last received SPI Message was correctly processed by the device. 0_B Previous Message was processed correctly. 1_B Previous Message was discarded.
P	0	rh	Parity Bit Odd Parity Bit.

Secondary OCP Blanking Time Register

This register configures the blanking time of the OCP function.

SOCP	Offset	Wakeup Value	Reset Value
Secondary OCP Blanking Time Register	19 _H	n.a.	0001 _H

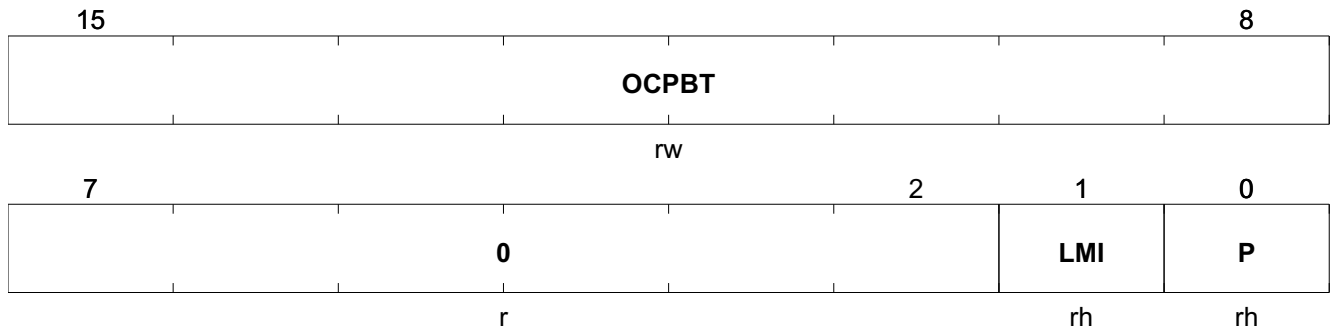

Field	Bits	Type	Description
OCPBT	15:8	rw	OCP Blanking Time This bit field defines the blanking time of the OCP function (in OSC2 clock cycles). Writing 0 _H to this field deactivates the digital blanking time generation. If used, a minimal value of at least A _H has to be programmed.
0	7:2	r	Reserved Read as 0 _B .
LMI	1	rh	Last Message Invalid Notification This bit indicates if the last received SPI Message was correctly processed by the device. 0 _B Previous Message was processed correctly. 1 _B Previous Message was discarded.
P	0	rh	Parity Bit Odd Parity Bit.

Secondary Regular TTOFF Configuration Register

This register shows the configuration of the TTOFF function for regular turn-off.

SRTTOF	Offset	Wakeup Value	Reset Value
Secondary Regular TTOFF Configuration Register	1A _H	n.a.	0001 _H

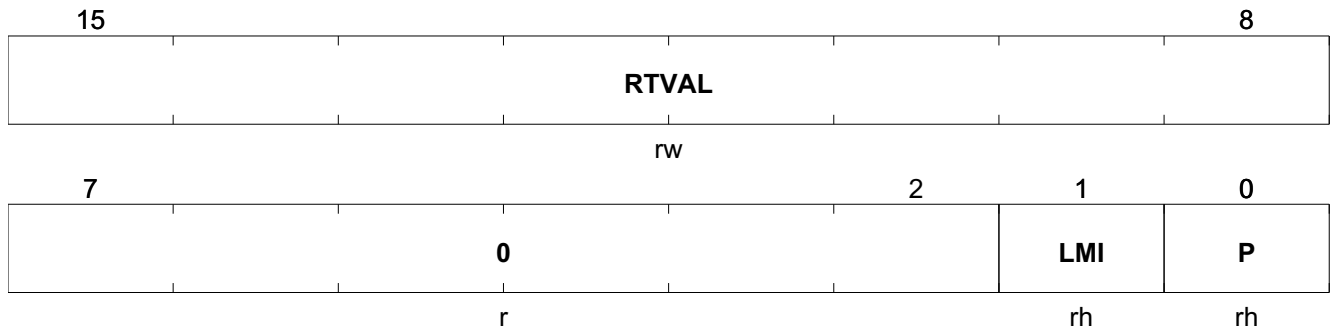

Field	Bits	Type	Description
RTVAL	15:8	rw	Gate Regular TTOFF delay This bit field defines the TTOFF delay for a regular turn-off (in SSOSC2 clock cycles). Writing 00 _H to this field deactivates the TTOFF function for regular turn-off. If used, a value greater than 02 _H has to be programmed.
0	7:2	r	Reserved Read as 0 _B .
LMI	1	rh	Last Message Invalid Notification This bit indicates if the last received SPI Message was correctly processed by the device. 0 _B Previous Message was processed correctly. 1 _B Previous Message was discarded.
P	0	rh	Parity Bit Odd Parity Bit.

Secondary Safe TTOFF Configuration Register

This register shows the configuration of the TTOFF function for safe turn-off.

SSTOF	Offset	Wakeup Value	Reset Value
Secondary Safe TTOFF Configuration Register	1B _H	n.a.	2081 _H

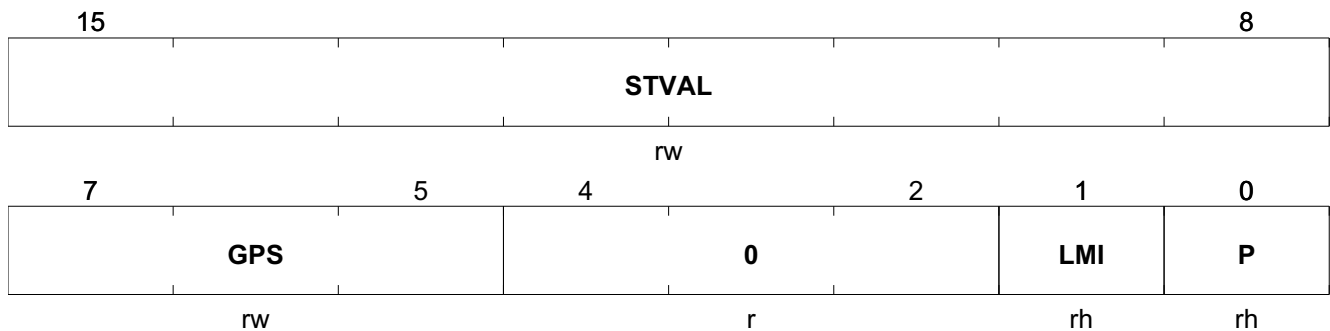

Field	Bits	Type	Description
STVAL	15:8	rw	<p>Gate Safe TTOFF delay</p> <p>This bit field defines the TTOFF delay for a safe turn-off (in OSC2 clock cycles). Writing 00_H to this field deactivates the TTOFF function for regular turn-off. if used, a minimal value of at least 0A_H has to be programmed.</p> <p><i>Note:</i></p> <p>4. In OPM5 and OPM6, it is recommended to have this bit field programmed to 0_H.</p> <p>5. In OPM4, bit field STVAL shall be programmed with a higher value than field SRTTOF.RTVAL.</p> <p>6.</p>
GPS	7:5	rw	<p>Gate Safe TTOFF Plateau Voltage</p> <p>This bit field defines the TTOFF plateau voltage for safe turn-off sequences. Coding is identical to PCTRL2.GPOF.</p> <p><i>Note:</i> In OPM4, bit field GPS shall be programmed with a value smaller or equal than field PCTRL2.GPOF.</p>
0	4:2	r	<p>Reserved</p> <p>Read as 0_B.</p>

Register Description

Field	Bits	Type	Description
LMI	1	rh	<p>Last Message Invalid Notification This bit indicates if the last received SPI Message was correctly processed by the device.</p> <p>0_B Previous Message was processed correctly. 1_B Previous Message was discarded.</p>
P	0	rh	<p>Parity Bit Odd Parity Bit.</p>

Secondary TTON Configuration Register

This register shows the configuration of the TTON function for regular turn-on.

STTON	Offset	Wakeup Value	Reset Value
Secondary TTON Configuration Register	1C _H	n.a.	0001 _H

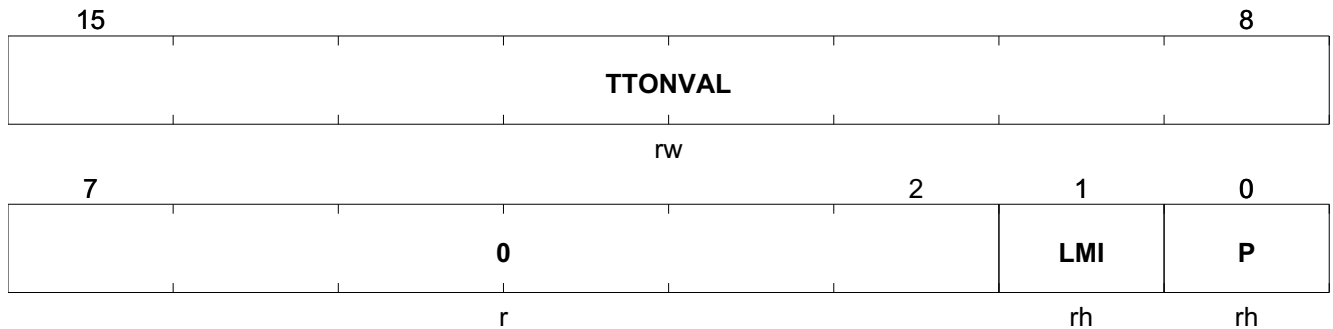

Field	Bits	Type	Description
TTONVAL	15:8	rw	Gate TTON Delay This bit field defines the TTON delay (in SSOSC2 clock cycles). Writing 00 _H to this field deactivates the TTON function. If used, a minimal value of at least A _H has to be programmed.
0	7:2	r	Reserved Read as 0 _B .
LMI	1	rh	Last Message Invalid Notification This bit indicates if the last received SPI Message was correctly processed by the device. 0 _B Previous Message was processed correctly. 1 _B Previous Message was discarded.
P	0	rh	Parity Bit Odd Parity Bit.

Secondary ADC Result Register

This register provides status of the ADC channel.

SADC	Offset	Wakeup Value	Reset Value
Secondary ADC Result Register	1D _H	n.a.	0001 _H

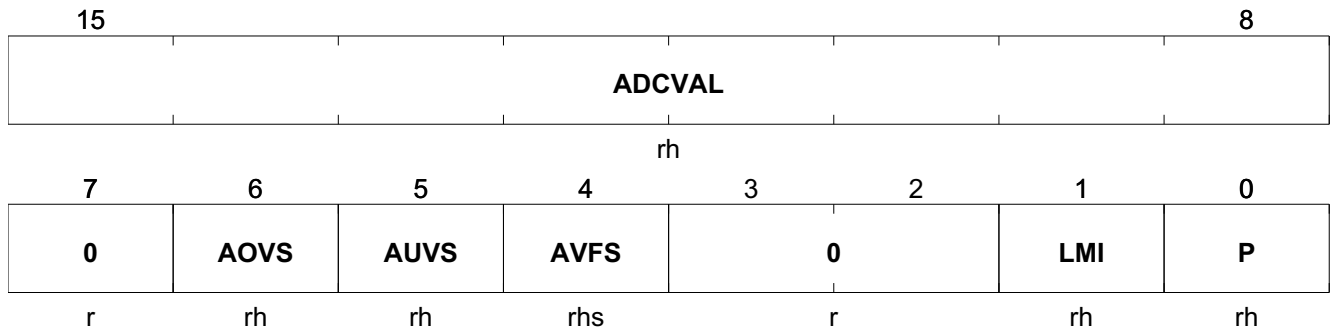

Field	Bits	Type	Description
ADCVAL	15:8	rh	ADC Result This bit field shows the results of the last conversion of the ADC channel. It is automatically updated every time a new conversion result is available.
0	7	r	Reserved Read as 0 _B .
AOVS	6	rh	ADC Overvoltage Error Status This bit indicates if a boundary condition violation is occurring (Overvoltage). 0 _B noError An error condition is not detected. 1 _B error An error condition is being detected
AUVS	5	rh	ADC Undervoltage Error Status This bit indicates if a boundary condition violation is occurring (undervoltage). 0 _B noError An error condition is not detected. 1 _B error An error condition is being detected
AVFS	4	rhs	ADC Result Valid Flag This bit indicates if a new value is available. This bit is set everytime bitfield ADCVAL is updated with a new value. This bit is sticky. 0 _B notValid ADC result is not valid. 1 _B valid ADC result is valid.
0	3:2	r	Reserved Read as 0 _B .

Register Description

Field	Bits	Type	Description
LMI	1	rh	Last Message Invalid Notification This bit indicates if the last received SPI Message was correctly processed by the device. 0 _B Previous Message was processed correctly. 1 _B Previous Message was discarded.
P	0	rh	Parity Bit Odd Parity Bit.

Secondary ADC Boundary Register

This register contains the values for the ADC boundary check. It can only be written if **SCFG.CFG2** is set.

SBC	Offset	Wakeup Value	Reset Value
Secondary ADC Boundary Register	1E _H	n.a.	FC01 _H

15	10	9	8
LCB1B		LCB1A	
rw		rw	
7	4	3	2
LCB1A		0	1
rw		r	rh
		rh	0
		rh	P
		rh	rh

Field	Bits	Type	Description
LCB1B	15:10	rw	ADC Limit Checking Boundary B Second boundary used for the limit check mechanism. Should be used as upper limit.
LCB1A	9:4	rw	ADC Limit Checking Boundary A First boundary used for the limit check mechanism. Should be used as lower limit.
0	3:2	r	Reserved Read as 0 _B .
LMI	1	rh	Last Message Invalid Notification This bit indicates if the last received SPI Message was correctly processed by the device. 0 _B Previous Message was processed correctly. 1 _B Previous Message was discarded.
P	0	rh	Parity Bit Odd Parity Bit.

Secondary Clock Supervision Register

This register is for internal purpose only.

SCS	Offset	Wakeup Value	Reset Value
Secondary Clock Supervision Register	1F _H	n.a.	0001 _H

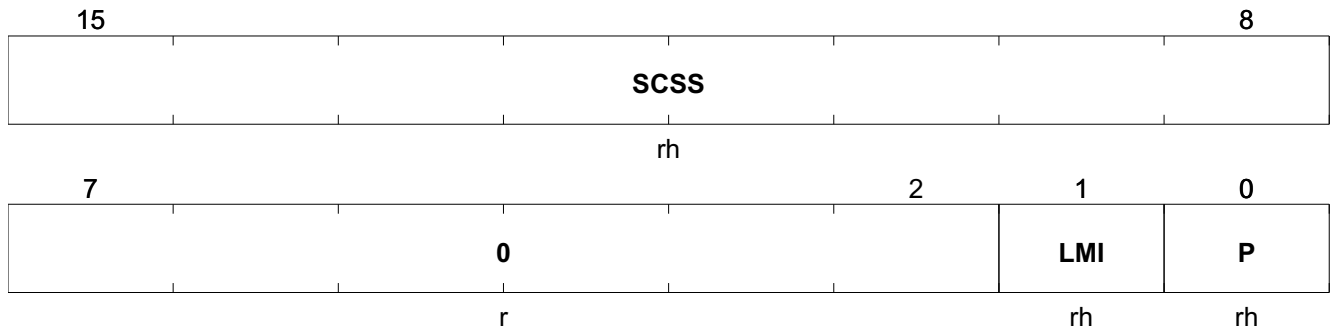

Field	Bits	Type	Description
SCSS	15:8	rh	Secondary Supervision Oscillator Clock Cycles This bit field is written by hardware by the TCF function and gives the number of measured Start Stop Oscillator clock cycles.
0	7:2	r	Reserved Read as 0 _B .
LMI	1	rh	Last Message Invalid Notification This bit indicates if the last received SPI Message was correctly processed by the device. 0 _B Previous Message was processed correctly. 1 _B Previous Message was discarded.
P	0	rh	Parity Bit Odd Parity Bit.

4.3 Read / Write Address Ranges

Table 4-4 summarizes which register is accessible with a READ command for a given operating mode.

Table 4-4 Read Access Validity

	OPM0/1	OPM2	OPM3	OPM4	OPM5	OPM6
PID	X	X	X	X	X	X
PSTAT	X	X	X	X	X	X
PSTAT2	X	X	X	X	X	X
PER	X	X	X	X	X	X
PCFG	X	X	X	X	X	X
PCFG2	X	X	X	X	X	X
PCTRL	X	X	X	X	X	X
PCTRL2	X	X	X	X	X	X
PSCR	X	X	X	X	X	X
PRW	X	X	X	X	X	X
PPIN	X	X	X	X	X	X
PCS	X	X	X	X	X	X
SID	X	X	X	X ¹⁾	X	X ¹⁾
SSTAT	X	X	X	X ¹⁾	X	X ¹⁾
SSTAT2	X	X	X	X ¹⁾	X	X ¹⁾
SER	X	X	X	X ¹⁾	X	X ¹⁾
SCFG	X	X	X	X ¹⁾	X	X ¹⁾
SCFG2	X	X	X	X ¹⁾	X	X ¹⁾
SSCR	X	X	X	X ¹⁾	X	X ¹⁾

Table 4-4 Read Access Validity (cont'd)

	OPM0/1	OPM2	OPM3	OPM4	OPM5	OPM6
SDESAT	X	X	X	X ₁₎	X	X ₁₎
SOCP	X	X	X	X ₁₎	X	X ₁₎
SRTTOF	X	X	X	X ₁₎	X	X ₁₎
SSTTOF	X	X	X	X ₁₎	X	X ₁₎
STTON	X	X	X	X ₁₎	X	X ₁₎
SADC	X	X	X	X ₁₎	X	X ₁₎
SBC	X	X	X	X ₁₎	X	X ₁₎
SCS	X	X	X	X ₁₎	X	X ₁₎

1) Increased latency time

Table 4-5 summarizes which register is accessible with a WRITEL command for a given operating mode.

Table 4-5 Write Access Validity

	OPM0/1	OPM2	OPM3	OPM4	OPM5	OPM6
PID						
PSTAT						
PSTAT2						
PER						
PCFG		X				
PCFG2		X				
PCTRL	X	X	X	X	X	X
PCTRL2	X	X	X	X	X	X
PSCR		X				
PRW	X	X	X	X	X	X
PPIN						
PCS						
SID						
SSTAT						
SSTAT2						
SER						
SCFG		X				
SCFG2 1)		X				
SSCR		X				

Table 4-5 Write Access Validity (cont'd)

	OPM0/1	OPM2	OPM3	OPM4	OPM5	OPM6
SDESAT		X				
SOCP		X				
SRTTOF		X				
SSTTOF		X				
STTON		X				
SADC 1)						
SBC		X				
SCS						

1) Write access only if bit **SCFG.CFG2** is set.

5 Specification

5.1 Typical Application Circuit

Table 5-1 Component Values

Parameter	Symbol	Values			Unit	Note / Test Condition
		Min.	Typ.	Max.		
Decoupling Capacitance (Between VEE2 and GND2)	C_d	2 x 0.5	11	-	μF	10 μF capacitance next to the power supply source (e.g. flyback converter). 1 μF close to the device. It is strongly recommended to have at least two capacitances close to the device (e.g. 2 x 500nF).
Decoupling Capacitance (Between VCC2 and GND2)	C_d	-	11	-	μF	10 μF capacitance next to the power supply source (e.g. flyback converter). 1 μF close to the device.
Decoupling Capacitance (Between VCC1 and GND1)	C_d	-	11	-	μF	10 μF capacitance next to the power supply source (e.g. flyback converter). 1 μF close to the device.
Series Resistance	R_{s1}	0	1	-	$\text{k}\Omega$	
Pull-up Resistance	R_{pu1}	-	10	-	$\text{k}\Omega$	
Filter Resistance	R_1	-	1	-	$\text{k}\Omega$	
Filter Capacitance	C_1	-	47	-	pF	
Reference Resistance	R_{ref1}	-	26.7 ¹⁾	-	$\text{k}\Omega$	high accuracy, as close as possible to the device
Reference Capacitance	C_{ref1}	-	100	-	pF	As close as possible to the device.
Pull-up Resistance	R_{pu2}	-	10	-	$\text{k}\Omega$	
Reference Resistance	R_{ref2}	-	23.7 ¹⁾	-	$\text{k}\Omega$	high accuracy, as close as possible to the device
Reference Capacitance	C_{ref2}	-	100	-	pF	As close as possible to the device.
DESAT filter Resistance	R_{desat}	1	3	-	$\text{k}\Omega$	Depends on required response time.
DESAT filter Capacitance	C_{desat}	-	n/a	-	pF	Depends on required response time.
DESAT Diode	D_{desat}	-	n/a	-	-	HV diode.
Sense Resistance	R_{sense}	-	n/a	-	Ω	Depends on IGBT specification.
OCP filter Capacitance	C_{ocp}	-	n/a	-	pF	Depends on required response time.

Table 5-1 Component Values (cont'd)

Parameter	Symbol	Values			Unit	Note / Test Condition
		Min.	Typ.	Max.		
OCP & OCPG resistance	R_{ocp} , R_{ocpg}	0	-	100	Ω	Depends on required response time.
DACL P filter Resistance	R_{daclp}	-	1	-	$k\Omega$	
DACL P filter Capacitance	C_{daclp}	-	470	-	pF	
Active Clamping Resistance	R_{acl1}	-	n/a	-	Ω	Depends on application requirements
Active Clamping Resistance	R_{acl2}	-	n/a	-	$k\Omega$	Depends on application requirements
Active Clamping Capacitance	C_{acli}	-	n/a	-	nF	Depends on application requirements
TVS Diode	D_{tvsac1} , D_{tvsac2}	-	n/a	-	-	Depends on application requirements
Active Clamping Diode	D_{acl}	-	n/a	-	-	Depends on application requirements
ACLI Clamping Diode	D_{acl2}	-	n/a	-	-	Depends on application requirements
VREG Capacitance	C_{vreg}		1		μF	As close as possible to the device.
GATE Resistance	R_{gon}	0.5	-	-	Ω	
GATE Resistance	R_{goff}	0.5	-	-	Ω	
GATE Clamping Diode	D_{gcl1}	-	n/a	-	-	²⁾
GATE Clamping Diode	D_{gcl2}	-	n/a	-	-	E.g. Schottky Diode. ²⁾
GATE Series Resistance	R_{gate}	0	10	-	Ω	Optional component.
VEE2 Clamping Diode	D_{gcl3}	-	n/a	-	-	E.g. Schottky Diode. ²⁾
ADC filter Resistance	R_{adc}	-	10	-	Ω	
ADC filter Capacitance	C_{adc}	-	1	-	nF	

1) If other values are used functionality of IC not guaranteed.

2) Characteristics of this components are application specific.

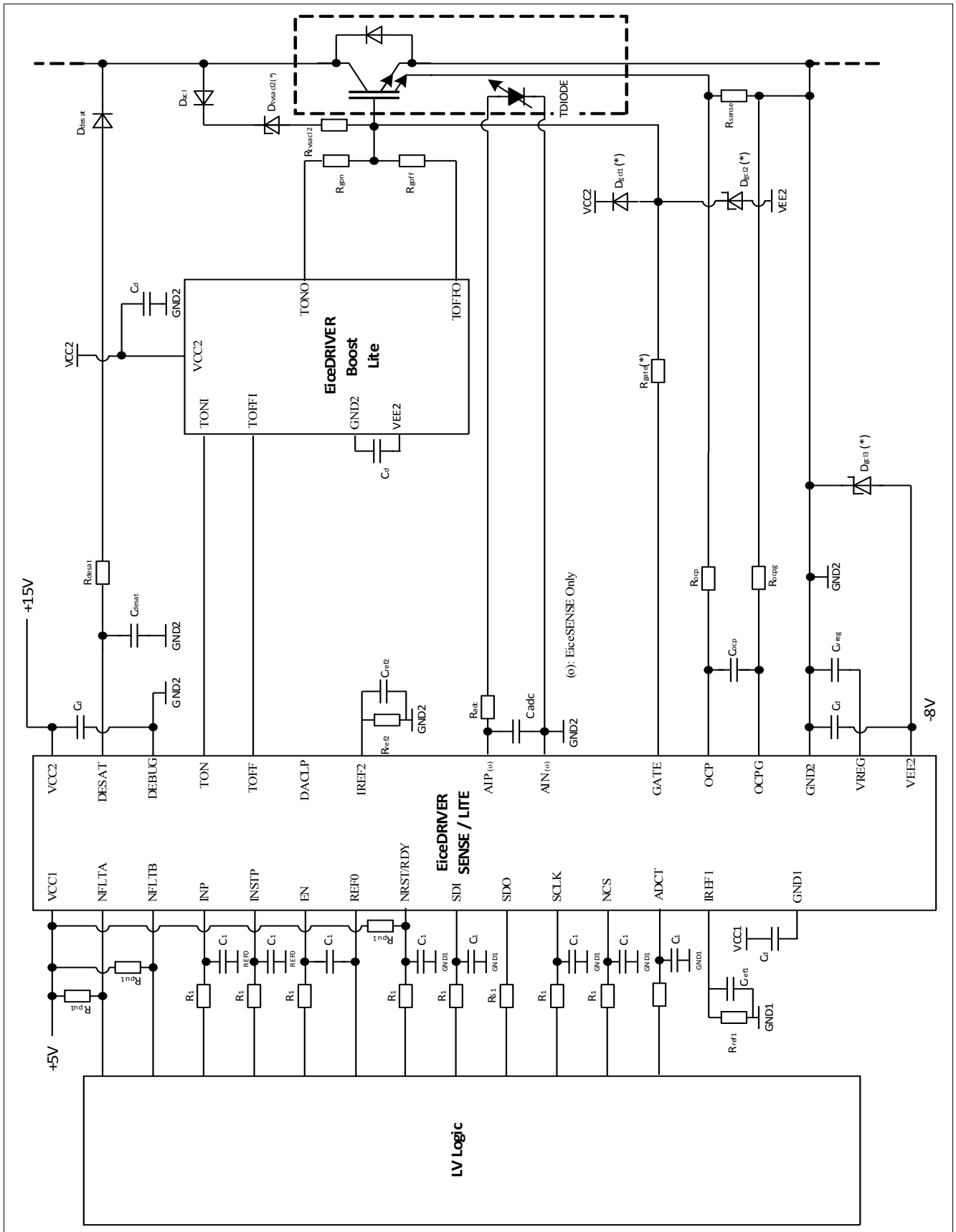

Figure 5-1 Typical Application Example

5.2 Absolute Maximum Ratings

Stress above the maximum values listed here may cause permanent damage to the device. Exposure to absolute maximum rating conditions for extended periods may affect device reliability.

Table 5-2 Absolute Maximum Ratings¹⁾

Parameter	Symbol	Values			Unit	Note / Test Condition
		Min.	Typ.	Max.		
Junction temperature	T _{JUNC}	-40	-	150	°C	
Storage temperature	T _{STO}	-55	-	150	°C	
Positive power supply (primary)	V _{CC1}	-0.3	-	6.0	V	Referenced to GND1
Positive power supply (secondary)	V _{CC2}	-0.3	-	28	V	Referenced to GND2
Negative power supply	V _{EE2}	-13	-	0.3	V	Referenced to GND2
Power supply voltage difference (secondary) V _{CC2} -V _{EE2}	V _{DS2}	-	-	40	V	
Voltage on any I/O pin on primary side except INP , INSTP , EN	V _{IN1}	-0.3	-	6.0	V	Referenced to GND1
Voltage on INP , INSTP , EN pins	V _{INR1}	-0.3	-	6.0	V	Referenced to REF0 ²⁾
Voltage difference between REF0 and GND1	V _{DG1}	-4	-	4	V	
Voltage difference between OCPG and GND2	V _{OCPG2}	-0.3	-	0.3	V	
Output current on push-pull I/O on primary side	I _{OUTPP1}	-	-	20	mA	
Output current on push-pull I/O on secondary side	I _{OUTPP2}	-	-	5	mA	
Output current on open drain I/O on primary side	I _{OUTOD1}	-	-	20	mA	
VREG Output DC current	I _{REG2}	-	-	525	µA	C _{LOAD} =1µF
Voltage on 5 V pin on sec. side	V _{IN52}	-0.3	-	6.0	V	Referenced to GND2
Voltage on 15 V pin on secondary side.	V _{IN152}	V _{EE2} -0.3	-	V _{CC2} +0.3	V	Referenced to GND2 , except DESAT
Voltage on DESAT pin.	V _{INDESAT}	-0.3	-	V _{CC2} +0.3	V	Referenced to GND2
Power Dissipation - Pri. Chip	P _{DISMAX1}	-	-	100	mW	T _{AMB} =125°C
Power Dissipation - Sec. Chip	P _{DISMAX2}	-	-	600	mW	T _{AMB} =125°C
ESD Immunity	V _{ESD}	-	-	2	kV	HBM ³⁾
		-	-	750	V	CDM ⁴⁾ , pins 1, 16, 17, 36
		-	-	500	V	CDM ⁴⁾ , all other pins
MSL Level	MSL	n.a.	3	n.a.		

1) Not subject to production test. Absolute maximum Ratings are verified by design / characterization.

2) Max. voltage of V_{INR1}+V_{DG1} should be below 7V.

3) According to EIA/JESD22-A114-B.

4) According to JESD22-C101-C.

5.3 Operating range

The following operating conditions must not be exceeded in order to ensure correct operation of the 1EDI2010AS. All parameters specified in the following sections refer to these operating conditions, unless otherwise noticed.

Table 5-3 Operating Conditions

Parameter	Symbol	Values			Unit	Note / Test Condition
		Min.	Typ.	Max.		
Ambient temperature	T_{amb}	-40	-	125	°C	
Positive power supply (primary)	V_{CC1}	4.65	5.0	5.5	V	Referenced to GND1 ¹⁾
Positive power supply (secondary)	V_{CC2}	13.0	15.0	18.0	V	Referenced to GND2 ²⁾
Negative power supply	V_{EE2}	-10.0	-8.0	0	V	Referenced to GND2 ³⁾
PWM switching frequency	f_{sw}	-	-	30	kHz	4)
Common Mode Transient Immunity	dV_{ISO}/dt	-100	-	100	kV/ μ s	At 1000 V ⁵⁾
Pulsed Magnetic Field Transient Immunity	H_{ISO}	-1000	-	1000	A/m	$t_r=10s$ ⁵⁾⁶⁾

1) Deterministic and correct operation of the device is guaranteed down to V_{UVLO1L} .

2) Deterministic and correct operation of the device is guaranteed down to V_{UVLO2L} .

3) Deterministic and correct operation of the device is guaranteed up to 0.3V.

4) Maximum junction temperature of the device must not be exceeded.

5) Not subject to production test. This parameter is verified by design / characterization.

6) As per IEC 61000-4-9

5.4 Thermal Characteristics

The indicated thermal parameters apply to the full operating range, unless otherwise specified.

Table 5-4 Thermal Characteristics

Parameter	Symbol	Values			Unit	Note / Test Condition
		Min.	Typ.	Max.		
Thermal Resistance Junction to Ambient	R_{THJA}	-	60	-	K/W	$T_{amb}=125^{\circ}C$ ¹⁾²⁾
Thermal Resistance Junction to Case	R_{THJC}	-	-	41	K/W	$T_{amb}=125^{\circ}C$ ¹⁾

1) Not subject to production test. This parameter is verified by design / characterization.

2) The thermal characteristics are done with a 6 layers board with the dimension 30mm x 40mm x 1.5mm and a cu-thickness of 35 μ m each layer (cooling areas should be foreseen on top and bottom, but shouldn't cover the isolation area of the IC).

5.5 Electrical Characteristics

The indicated electrical parameters apply to the full operating range, unless otherwise specified.

5.5.1 Power Supply

Table 5-5 Power Supplies Characteristics

Parameter	Symbol	Values			Unit	Note / Test Condition
		Min.	Typ.	Max.		
UVLO1 Threshold High	V_{UVLO1H}	4.20	4.47	4.65	V	Referenced to GND1
UVLO1 Threshold Low	V_{UVLO1L}	4.20	4.40	4.60	V	Referenced to GND1
UVLO1 Hysteresis	$V_{UVLO1HYS}$	40	70	-	mV	
UVLO2 Threshold High	$V_{UVLO2H0}$	11.5	12.5	13.0	V	Referenced to GND2
	$V_{UVLO2H1}$	9.5	10.25	11	V	Referenced to GND2
UVLO2 Threshold Low	$V_{UVLO2L0}$	11.0	11.7	12.5	V	Referenced to GND2
	$V_{UVLO2L1}$	9	9.75	10.5	V	Referenced to GND2
UVLO2 Hysteresis	$V_{UVLO2HY0}$	500	850	-	mV	$V_{UVLO2H0/L0}$ selected
	$V_{UVLO2HY1}$	400	500	-	mV	$V_{UVLO2H1/L1}$ selected
V_{CC2} Reset Level	V_{RST2}	7.9	8.3	8.8	V	Referenced to GND2
Quiescent Current Input Chip	I_{Q1}	-	7.5	10	mA	$V_{CC1}=5V$, all I/Os inactive
Quiescent Current Output Chip VCC2	I_{QVCC2}	-	11	13	mA	$V_{CC2}=15V$, $V_{EE2}=-8V$, all I/Os inactive
Quiescent Current Output Chip VEE2	I_{QVEE2}	-	1	2	mA	$V_{CC2}=15V$, $V_{EE2}=-8V$, all I/Os inactive
VCC1 ramp-up / down time	t_{RP1}	-	-	0.5	V/ms	Absolute value
VCC2 ramp-up / down time	t_{RP2}	-	-	1.5	V/ms	Absolute value
VEE2 ramp-up / down time	t_{RP3}	-	-	0.8	V/ms	Absolute value
Power Dissipation - Primary Chip	P_{DIS1}	-	37.5	-	mW	$T_{AMB}=25^{\circ}C$
Power Dissipation - Secondary Chip	P_{DIS2}	-	175	-	mW	$T_{AMB}=25^{\circ}C$, idle mode

5.5.2 Internal Oscillators

Table 5-6 Internal Oscillators

Parameter	Symbol	Values			Unit	Note / Test Condition
		Min.	Typ.	Max.		
Primary / Secondary main oscillator frequency	f_{clk1}	14.0	16.6	19.1	MHz	Resistances on pin IREF1 nominal
Start/Stop Oscillator Frequency	f_{clk2}, f_{clkst2}	15.0	17.1	19.0	MHz	Resistances on pin IREF2 nominal

5.5.3 Primary I/O Electrical Characteristics

Table 5-7 Electrical Characteristics for Pins: INP, INSTP, EN

Parameter	Symbol	Values			Unit	Note / Test Condition
		Min.	Typ.	Max.		
Low Input Voltage	V_{INPRL1}	0	-	$0.3 \times V_{CC1}$	V	Referenced to REF0
High Input Voltage	V_{INPRH1}	$0.7 \times V_{CC1}$	-	V_{CC1}	V	Referenced to REF0
Weak pull down resistance	R_{PDIN1}	20	-	100	$k\Omega$	Referenced to REF0
Input Current	I_{INPR1}	-	-	300	μA	
Input Pulse Suppression	t_{INPR1}	-	20	-	ns	1)
Time between EN valid and INP High Level	t_{INPEN}	8	-	-	μs	2)
INP High / Low Duration	t_{INPPD}	250	-	-	ns	
INSTP High / Low Duration	$t_{INSTPPD}$	250	-	-	ns	
Minimum EN High or Low duration time.	t_{ENDC}	10	-	-	μs	2)

1) Not subject to production test. This parameter is verified by design / characterization.

2) Timing is given for hard ON/OFF switching condition only.

Table 5-8 Electrical Characteristics for Pins: NRST/RDY, SCLK, SDI, NCS, DIO1 (input), ADCT

Parameter	Symbol	Values			Unit	Note / Test Condition
		Min.	Typ.	Max.		
Low Input Voltage	V_{INPL1}	0	-	$0.3 \times V_{CC1}$	V	Referenced to GND1
High Input Voltage	V_{INPH1}	$0.7 \times V_{CC1}$	-	V_{CC1}	V	Referenced to GND1
Weak pull up resistance SCLK, SDI, NCS	R_{PUSP11}	25	-	100	$k\Omega$	Referenced to VCC1
Weak pull down resistance DIO1, ADCT	$R_{PDADD11}$	25	-	100	$k\Omega$	Referenced to GND1
Input Current	I_{INP1}	-	-	400	μA	
NRST/RDY Output Voltage in Non-Ready conditions.	V_{OUTNR}	-	-	1	V	$V_{CC1}=5V, I_{load} = 2 \text{ mA}$
		-	0.7	1	V	$V_{CC1}=0V, I_{load} = 500 \mu A$
NRST/RDY driven-active time after power supplies are within operating range.	t_{RST}	-	15.4	-	μs	1)
NRST/RDY minimum activation time.	t_{RSTAT}	10	-	-	μs	
Minimum DIO1 High or Low duration time.	t_{DIO1DC}	10	-	-	μs	When configured as input
Minimum ADCT High or Low duration time.	t_{ADCTDC}	20	-	-	μs	

1) Not subject to production test. This parameter is verified by design / characterization.

Table 5-9 Electrical Characteristics for Pins: SDO, DIO1 (output)

Parameter	Symbol	Values			Unit	Note / Test Condition
		Min.	Typ.	Max.		
Low Output Voltage	V_{OUTPL1}	-	-	0.5	V	$I_{load} = 5 \text{ mA}$
High Output Voltage	V_{OUTPH1}	3.85	-	-	V	$I_{load} = 5 \text{ mA}$

Table 5-10 Electrical Characteristics for Pins: NFLTA, NFLTB

Parameter	Symbol	Values			Unit	Note / Test Condition
		Min.	Typ.	Max.		
Low Output Voltage	V_{OUTDL1}	-	-	0.5	V	$I_{SINK} = 5 \text{ mA}$

5.5.4 Secondary I/O Electrical Characteristics

Table 5-11 Electrical Characteristics for Pins: TON, TOFF & GATE

Parameter	Symbol	Values			Unit	Note / Test Condition
		Min.	Typ.	Max.		
TON & TOFF Output Voltage High	V_{150H2}	$V_{CC2}-1$	-	$V_{CC2}+0.3$	V	Referenced to GND2
TON & TOFF Output Voltage Low	V_{150L2}	$V_{EE2}-0.3$	-	$V_{EE2}+1$	V	Referenced to GND2
TON & TOFF Source / Sink Current	I_{1502}	1	-	-	A	¹⁾²⁾
GATE Input voltage range	V_{15GATE}	V_{EE2}	-	V_{CC2}	V	Referenced to GND2
Passive Clamping Voltage	V_{PCLP}	-	-	$V_{EE2}+1$	V	Secondary chip not supplied, TON, TOFF & GATE shorted, $I_{CLAMP}=10$ mA.
Passive Clamp Current	I_{PCLP}	5	-	-	mA	Secondary chip not supplied, TON, TOFF & GATE shorted, $V_{GATE}=V_{EE2}+2V$

1) Not subject to production test. This parameter is verified by design / characterization.

2) Thermally limited.

Table 5-12 Electrical Characteristics for Pins: DEBUG, DIO2(input)

Parameter	Symbol	Values			Unit	Note / Test Condition
		Min.	Typ.	Max.		
Low Input Voltage	V_{5INL2}	0	-	1.5	V	Referenced to GND2
High Input Voltage	V_{5INH2}	3.5	-	5.5	V	Referenced to GND2
Weak pull down resistance	R_{PDIN2}	20	-	80	k Ω	Connected to GND2

Table 5-13 Electrical Characteristics for Pins: DIO2, DACLP (Output)

Parameter	Symbol	Values			Unit	Note / Test Condition
		Min.	Typ.	Max.		
Output Voltage High	V_{50H2}	4.0	-	5.25	V	Referenced to GND2 , $I_{load}=2$ mA, $V_{REG2}=typ.$
Output Voltage Low	V_{50L2}	0	-	0.5	V	Referenced to GND2 , $I_{load}=2$ mA
Minimum DIO2 High or Low duration time.	t_{DIO2DC}	10	-	-	μ s	When configured as input

Table 5-14 Electrical Characteristics for Pin: AIP

Parameter	Symbol	Values			Unit	Note / Test Condition
		Min.	Typ.	Max.		
Voltage Range for Current Source	V_{AIP}	0	-	4.5	V	$I_{AIPCS} = \text{typ.}$
Current Source	I_{AIPCS}	-	1.05	-	mA	$R_{ref2} = 23.7 \text{ k}\Omega^{1)}$
Output Current Source Error	I_{AIPCSE}	-3	-	3	%	Deviation from nominal value

1) Recommended resistance for specified limits. Other values may lead to malfunction.

5.5.5 Switching Characteristics

Table 5-15 Switching Characteristics

Parameter	Symbol	Values			Unit	Note / Test Condition
		Min.	Typ.	Max.		
Input to Output Propagation Delay ON	t_{PDON}	175	215	255	ns	$V_{CC1}=5V, V_{CC2}=15V, V_{EE2}=-8V$ ¹⁾
Input to Output Propagation Delay OFF	t_{PDOFF}	175	215	255	ns	$V_{CC1}=5V, V_{CC2}=15V, V_{EE2}=-8V$ ¹⁾
Input to Output Propagation Delay Distortion ($t_{PDOFF}-t_{PDON}$)	t_{PDISTO}	-50	0	50	ns	$V_{CC1}=5V, V_{CC2}=15V, V_{EE2}=-8V$
Input to Output Propagation Delay Distortion Variation for two consecutive pulses	$t_{PDISTOV}$	-	25	-	ns	$V_{CC1}=5V, V_{CC2}=15V, V_{EE2}=-8V, T_{JUNC}=25^{\circ}C$ ²⁾
Rise Time	t_{RISE}	-	120	205	ns	$V_{CC1}=5V, V_{CC2}=15V, V_{EE2}=-8V, C_{LOAD} = 10nF, 10\%-90\%$
		-	30	50	ns	$V_{CC1}=5V, V_{CC2}=15V, V_{EE2}=-8V, \text{no load}, 10\%-90\%$
Fall Time	t_{FALL}	-	150	235	ns	$V_{CC1}=5V, V_{CC2}=15V, V_{EE2}=-8V, C_{LOAD} = 10nF, 90\%-10\%$
		-	60	100	ns	$V_{CC1}=5V, V_{CC2}=15V, V_{EE2}=-8V, \text{no load}, 90\%-10\%$
Voltage during TTOFF Plateau level	V_{GPOF0}	5.4	6.0	6.3	V	Referenced to GND2 , measured at pin TON shorted with TOFF , no V_{BE} compensation, $V_{CC2}=15V, T_{JUNC}=25^{\circ}C$
	V_{GPOF1}	6.4	7.0	7.3	V	
	V_{GPOF2}	7.3	8.0	8.4	V	
	V_{GPOF3}	8.2	9.0	9.4	V	
	V_{GPOF4}	9.2	10.0	10.5	V	
	V_{GPOF5}	10.1	11.0	11.5	V	
	V_{GPOF6}	11.1	12.0	12.6	V	
Voltage during TTOFF Plateau level	V_{GPOF0}	4.7	5.3	5.6	V	Referenced to GND2 , measured at pin TON shorted with TOFF , with V_{BE} compensation, $V_{CC2}=15V, T_{JUNC}=25^{\circ}C$
	V_{GPOF1}	5.7	6.3	6.6	V	
	V_{GPOF2}	6.6	7.3	7.7	V	
	V_{GPOF3}	7.6	8.3	8.7	V	
	V_{GPOF4}	8.5	9.3	9.8	V	
	V_{GPOF5}	9.5	10.3	10.8	V	
	V_{GPOF6}	10.5	11.3	11.9	V	
	V_{GPOF7}	11.5	12.3	12.9	V	

Table 5-15 Switching Characteristics (cont'd)

Parameter	Symbol	Values			Unit	Note / Test Condition
		Min.	Typ.	Max.		
Temperature variation from configured $V_{TTOFF}(25^{\circ}\text{C}) @ T_J = -40^{\circ}\text{C}$	dV_{Tm40}	-	-110	-	mV	1)3)
Temperature variation from configured $V_{TTOFF}(25^{\circ}\text{C}) @ T_J = 150^{\circ}\text{C}$	dV_{T150}	-	110	-	mV	1)3)
TTOFF decrease rate	t_{SLEW}	-	9	-	V/ μs	
TTOFF delay deviation from nominal value	$t_{DEVTTTOFF}$	-100	0	100	ns	For a target time of 2 μs , using the TCF ¹⁾²⁾
TTOFF Plateau Time	t_{TTOFF}	-	2.6	-	μs	SRTTOF.RTVAL =26 _H
Voltage during TTON / WTO Plateau level	V_{GPON0}	5.6	6.0	6.4	V	Referenced to GND2 , measured at pin TON shorted with TOFF , no V_{BE} compensation, $V_{CC2}=15\text{V}, T_{JUNC}=25^{\circ}\text{C}$
	V_{GPON1}	6.5	7.0	7.5	V	
	V_{GPON2}	7.45	8.0	8.5	V	
	V_{GPON3}	8.4	9.0	9.6	V	
	V_{GPON4}	9.35	10.0	10.6	V	
	V_{GPON5}	10.3	11.0	11.7	V	
	V_{GPON6}	11.25	12.0	12.75	V	Referenced to GND2 , measured at pin TON shorted with TOFF , no V_{BE} compensation, $V_{CC2}=16.5\text{V}, T_{JUNC}=25^{\circ}\text{C}$
Voltage during TTON / WTO Plateau level	V_{GPON0}	6.2	6.7	7.1	V	Referenced to GND2 , measured at pin TON shorted with TOFF , with V_{BE} compensation, $V_{CC2}=15\text{V}, T_{JUNC}=25^{\circ}\text{C}$
	V_{GPON1}	7.15	7.7	8.15	V	
	V_{GPON2}	8.1	8.7	9.2	V	
	V_{GPON3}	9.0	9.7	10.3	V	
	V_{GPON4}	10.0	10.7	11.2	V	
	V_{GPON5}	10.7	11.4	12	V	
	V_{GPON6}	11.55	12.4	13.1	V	Referenced to GND2 , measured at pin TON shorted with TOFF , with V_{BE} compensation, $V_{CC2}=16.5\text{V}, T_{JUNC}=25^{\circ}\text{C}$
TTON Delay	t_{TTON}	-	8	-	μs	SCFG.TTONVAL =7 _{F_H}
DACL Delay	t_{ACL}	-	5	-	μs	4)

- 1) Values are valid only in case of stand-alone switching transistion.
- 2) Not subject to production test. Parameters are verified by design / characterization.
- 3) Measured without V_{BE} compensation.
- 4) If a following switching sequence is turning off during this time the delay will extend.

5.5.6 Desaturation Protection
Table 5-16 DESAT characteristics

Parameter	Symbol	Values			Unit	Note / Test Condition
		Min.	Typ.	Max.		
DESAT Input voltage range	$V_{15DESAT}$	0	-	V_{CC2}	V	Referenced to GND2
DESAT Reference Level	V_{DESAT0}	8.5	9	9.5	V	$V_{CC2} = 15V, V_{EE2} = -8V$
	V_{DESAT1}	2.9	3	3.1	V	
DESAT Pull-up Resistance	R_{DSATPU}	19	30	44	k Ω	$V_{CC2} = 15V, V_{EE2} = -8V, V_{DESAT} = 2V$
DESAT Low Voltage	V_{DESATL}	-	200	-	mV	Referenced to GND2, Desat clamping enabled, $I_{sink} = 5mA$.
DESAT blanking time deviation from programmed value	$dt_{DESATBL}$	-20	-	+20	%	After transition of the PWM command, assuming a 1 μs programmed blanking time ¹⁾

1) Not subject to production test. Parameters are verified by design / characterization.

5.5.7 Overcurrent Protection

Table 5-17 OCP characteristics

Parameter	Symbol	Values			Unit	Note / Test Condition
		Min.	Typ.	Max.		
OC error detection threshold	V_{OCP0}	277	300	318	mV	Referenced to OCPG
	V_{OCP1}	564	600	630	mV	Referenced to OCPG
OCP blanking time deviation from programmed value	dt_{OCPBL}	-20	-	+20	%	After transition of the PWM command, assuming a 1 μ s programmed blanking time ¹⁾
OCP Pull-up Resistance	R_{PUOCP2}	40	100	175	k Ω	to internal 5V reference.

1) Not subject to production test. Parameters are verified by design / characterization.

5.5.8 Low Latency Digital Channel

Table 5-18 Digital channel characteristics

Parameter	Symbol	Values			Unit	Note / Test Condition
		Min.	Typ.	Max.		
Input to output propagation time primary to secondary	t_{DPS}	-	2	4.5	μ s	¹⁾
Input to output propagation time secondary to primary	t_{DSP}	-	2	4.5	μ s	¹⁾

1) Given for single events only. If other communication events occur simultaneously max. timing will increase.

5.5.9 Error Detection Timing

Table 5-19 Error Detection Timing

Parameter	Symbol	Values			Unit	Note / Test Condition
		Min.	Typ.	Max.		
Dead Time for Shoot Through Protection	t_{DEAD}	800	-	1200	ns	Default Value ²⁾
Class A event detection to NFLTA activation	t_{AFLTA}	-	2	4.5	μ s	$V_{CC2}=typ., V_{CC1}=typ., V_{EE2}=typ.^{2)}$
Class A event detection to turn off sequence activation	t_{OFFCLA}	-	-	400	ns	$V_{TOFF}=V_{CC2} - 1 V, V_{CC2}=typ., V_{CC1}=typ., V_{EE2}=typ.^{2)}$
DESAT event detection to turn off sequence activation	$t_{OFFDESAT2}$	-	-	430	ns	$V_{TOFF}=V_{CC2} - 1 V, \text{ after blanking time elapsed, } V_{CC2}=typ., V_{CC1}=typ., V_{EE2}=typ.^{2)}$
OCP event occurrence to turn off sequence activation	$t_{OFFOCP2}$	-	-	150	ns	$V_{TOFF}=V_{CC2} - 1 V, \text{ after blanking time elapsed, } V_{CC2}=typ., V_{CC1}=typ., V_{EE2}=typ.^{2)}$
Class B event detection to NFLTB activation	t_{BFLTB}	-	2	4.5	μ s	$V_{CC2}=typ., V_{CC1}=typ., V_{EE2}=typ.^{2)}$
Class B event detection to turn off sequence activation	$t_{OFFCLB2}$	-	-	400	ns	$V_{TOFF}=V_{CC2} - 1 V, V_{CC2}=typ., V_{CC1}=typ., V_{EE2}=typ.^{1)2)}$
Verification Mode time out	t_{VMTO}	-	15	-	ms	After a transition from OPM2 to OPM5, SCFG.TOSEN = 0 _B ¹⁾²⁾
		-	60	-	ms	After a transition from OPM2 to OPM5, SCFG.TOSEN = 1 _B ¹⁾²⁾
Life sign error detection time	t_{LS}	-	5	-	μ s	After error condition detected by logic.

1) Verified by design / characterization. Not tested in production.

2) Deviation of the clock needs to be considered.

5.5.10 SPI Interface
Table 5-20 SPI Interface Characteristics

Parameter	Symbol	Values			Unit	Note / Test Condition
		Min.	Typ.	Max.		
SPI frame size	N_{bit}	N.a.	$N*16$	N.a.	bit	N is the daisy chain length
Baud rate	f_{CLK}	0.1	-	2	MHz	1)2)
Serial clock period	t_{SCLKp}	0.5	-	-	μs	3)
SCLK duty cycle	D_{SCLK}	45	-	55	%	3)
SDI set-up time	t_{SDIsu}	65	-	-	ns	3)
SDI hold time	t_{SDIh}	100	-	-	ns	3)
NCS lead time	t_{CSlead}	1	-	-	μs	3)
NCS trail time	t_{CStrail}	1	-	-	μs	3)
NCS inactive time	t_{CSinact}	10	-	-	μs	3)
SDO enable time	t_{SDOen}	-	-	500	ns	$C_{\text{load}} = 20\text{pF}^{3)}$
SDO disable time	t_{SDOdis}	-	-	1	μs	$C_{\text{load}} = 20\text{pF}^{3)}$
SDO valid time	t_{SDOv}	10	-	185	ns	$C_{\text{load}} = 20\text{pF}^{3)}$

- 1) Low Limit verified by design / characterization. Not tested in production.
- 2) In Daisy Chain the max. Baud rate is 1.8 MHz.
- 3) Verified by design / characterization. Not tested in production.

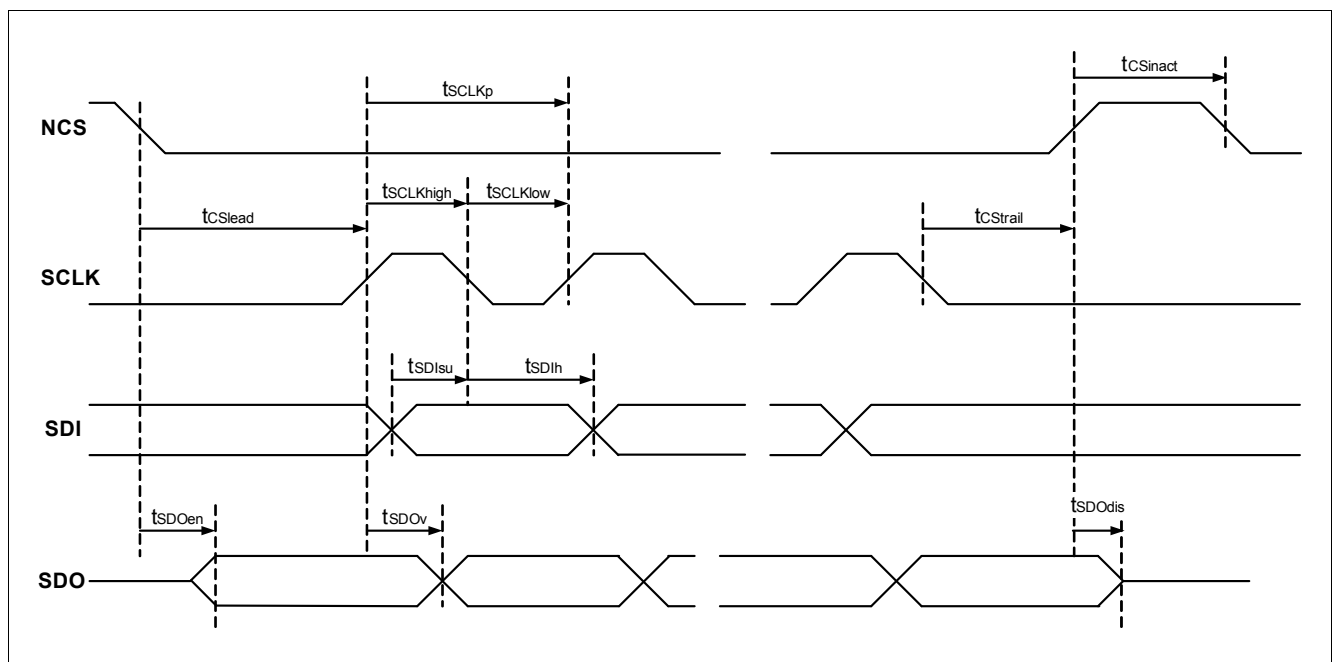
Figure 5-2 SPI Interface Timing

5.5.11 ADC
Table 5-21 ADC parameter

Parameter	Symbol	Values			Unit	Note / Test Condition
		Min.	Typ.	Max.		
ADC Resolution	Res	n.a.	8	n.a.	bit	¹⁾
Sampling time	t_{SMPL}	-	120	-	clock	¹⁾ , from ADC trigger active to end of sampling phase, in OSC2 domain.
Conversion time	t_{CONV}	-	211	-	clock	¹⁾ , from ADC trigger active to result available in the register, in OSC2 domain.
ADCT trigger signal propagation time	t_{PTRIG}	-	2	tbd	μs	¹⁾ , from valid signal on pin ADCT to start of conversion, external trigger mode only.
Internal Voltage Range ADC	V_{INT}	-	2.75	-	V	Resulting in 93 LSB/V
Preamplifier Gain	GAIN_0 , GAIN_1	-	2/3	-	-	Resulting in 62 LSB/V
	GAIN_2	-	1	-	-	Resulting in 93 LSB/V
	GAIN_3	-	2	-	-	Resulting in 186 LSB/V
ADC Offset	V_{OFF0}	-	0.0	-	V	
	V_{OFF1}	-	0.5	-	V	
	V_{OFF2}	-	1.0	-	V	
	V_{OFF3}	-	1.5	-	V	
	V_{OFF4}	-	2.0	-	V	
Offset Error	ER_{OFF}	-3.1	-	3.1	LSB	Neg. error results in min. offset. ²⁾
Gain Error	ER_{GAIN}	-5	-	5		Neg. error results in min. gain. ²⁾
INL	INL	-	1	1.6	LSB	²⁾
DNL	DNL	-	0.4	0.75	LSB	²⁾
Accuracy ³⁾	TUE	-	-	6.5	LSB	Neg. error results in min. value. ²⁾
Automatic trigger period	t_{ATRIG}	-	4	-	ms	¹⁾

1) Verified by design / characterization. Not tested in production.

2) Accuracy related parameters are defined when the device is not switching a PWM signal.

3) Total Unadjusted Error is the square sum of all worst rms errors (DNL, INL, ER_{OFF} and ER_{GAIN}).

5.5.12 Insulation Characteristics

Table 5-22 Isolation Characteristics referring to IEC 60747-5-2 (VDE 0884 - 10):2006-12

Description	Symbol	Characteristic	Unit
Installation classification per EN60664-1, Table 1: rated main voltage less than 150 V _{rms} rated main voltage less than 300 V _{rms} rated main voltage less than 600 V _{rms}		I - IV I - III I - II	
Climatic Classification		40 / 125 / 21	
Pollution Degree (EN 60664-1)		2	
Minimum External Clearance	CLR	8.12	mm
Minimum External Creepage	CPG	8.24	mm
Minimum Comparative Tracking Index	CTI	175	
Maximum Repetitive Insulation Voltage	V _{IORM}	1420	V _{PEAK}
Highest Allowable Overvoltage ¹⁾	V _{IOTM}	6000	V _{PEAK}
Maximum Surge Insulation Voltage	V _{IOSM}	6000	V _{PEAK}

1) Refer to VDE 0884 for a detailed description of Method a and Method b partial discharge

Table 5-23 Isolation Characteristics referring to UL 1577

Description	Symbol	Characteristic	Unit
Insulation Test Voltage / 1 min	V _{ISO}	3750	V _{rms}
Insulation Test Voltage / 1 sec	V _{ISO}	4500	V _{rms}

6 Package Information

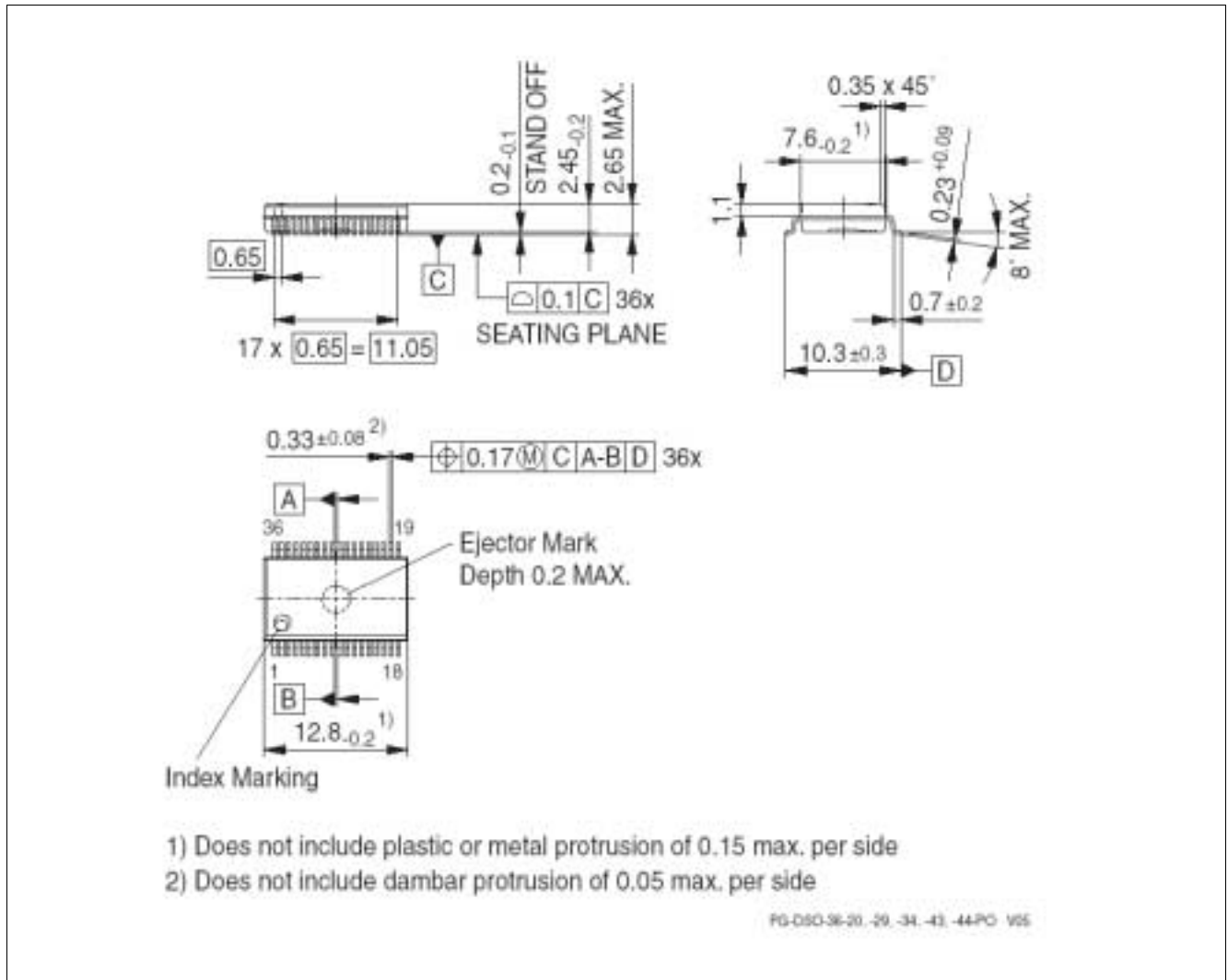

Figure 6-1 Package Dimensions

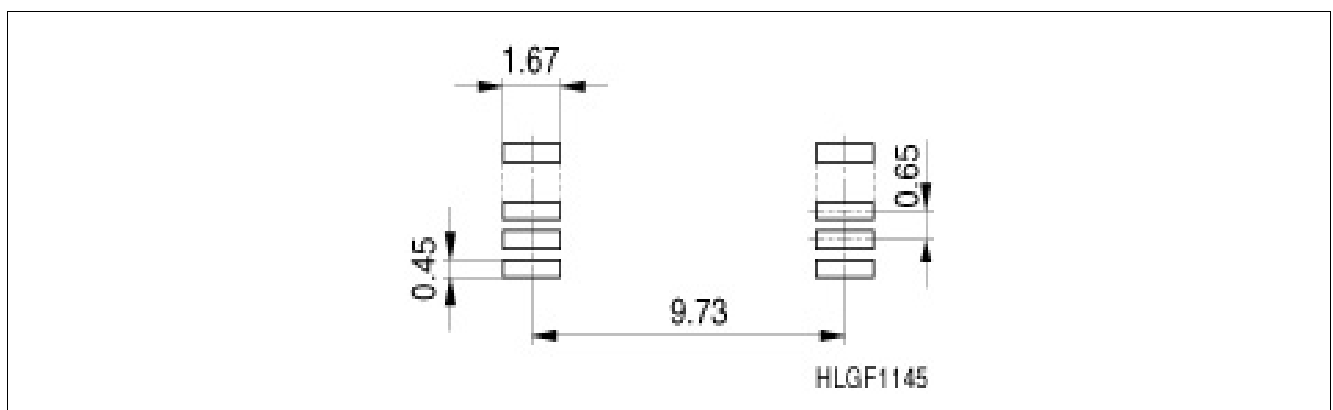

Figure 6-2 Recommended Footprint

www.infineon.com

Published by Infineon Technologies AG

Downloaded From [Oneyac.com](https://www.oneyac.com)

单击下面可查看定价，库存，交付和生命周期等信息

[>>Infineon\(英飞凌\)](#)